



**CITY OF FAIRHOPE
INVITATION TO BID**

SEALED BIDS will be received by the City of Fairhope of Baldwin County, Alabama, in the City of Fairhope's City Services and Public Utilities Building located at, 555 South Section St. Fairhope, Alabama, until 2:00 P.M. Tuesday, August 13, 2024, and then publicly opened thereafter, for furnishing all labor and materials, and performing all work required by the City of Fairhope and described as follows:

**Bid Number 24-060-2024-PWI-002
New Tennis & Pickleball Courts at Mike Ford Tennis Center
Public Works Project No. 2024-PWI 002**

The City of Fairhope is requesting responses from qualified contractors to provide all material, equipment, labor, and incidentals for the construction of twelve (12) pickleball courts (180' x 120'), two (2) tennis courts (60' x 120' each), and the resurfacing of an existing pickleball court to a tennis court (60' x 120') bituminous asphalt courts, the layout and surfacing of twelve (12) pickleball courts and three (3) tennis courts, new court fencing (with pedestrian and utility gates), construction of concrete sidewalks, and the provision and installation of the specified court equipment. This site is currently occupied by the City's recreational tennis and pickleball facility and will remain in full operation during project construction. Work will include but is not limited to clearing and grubbing, unclassified excavation, select fill, subbase processing, processing of aggregate base, asphalt wearing course, concrete sidewalk, finished surface leveling, construction of vinyl coated chain-link fencing & gates, layout, application of acrylic coatings and installation of sports equipment.

Bid documents will be posted on the City of Fairhope Website: www.FairhopeAL.gov or a copy may be obtained by e-mailing: Purchasing@FairhopeAL.gov. Specifications are on file and may be seen in the Purchasing Department of the City of Fairhope, Alabama, 555 S. Section Street. Prior to opening, Bid packages may be picked up at that location during normal operation, between 7:00 am and 4:00 pm local time.

Questions or comments pertaining to this bid must be presented in writing, sent as e-mail to the attention of the Purchasing Manager, Erin Wolfe, 555 South Section St., Fairhope, AL 36532, e-mail: Purchasing@FairhopeAL.gov, by Friday, August 9, 2024, at 11:00 A.M. or will be forever waived.

There will be a **MANDATORY** pre-bid meeting on Thursday, August 8, 2024, at 2:00 P.M. at the City Services and Public Utilities Building located at 555 South Section Street, Fairhope, AL.

The City of Fairhope is an Equal Opportunity Employer and requires that all **BIDDERS** comply with the Equal Employment Opportunity laws and the provisions of the CONTRACT Documents in this regard. The **CITY** also encourages and supports the utilization of Minority Business Enterprises on this and all public bids.

All bids must be on blank bid forms provided in the Bid Documents. All bids, with their guarantee (when required), must be enclosed in a sealed, opaque envelope, clearly identified on the outside as a "**Sealed Bid**" with **Item Name, Bid Number, City of Fairhope's Name and Address and CONTRACTOR's Name and Address**. Each bid must be in a separate envelope. Bids made out in pencil will not be accepted. Failure to observe the instructions contained herein will constitute grounds for rejection of your bid. The **City** reserves the right to accept or reject all bids or any portion thereof, and to waive informalities and to furnish any item of material or work to change the amount of the CONTRACT, whichever is in the best interest of the City of Fairhope.

No bids will be considered unless the **CONTRACTOR**, whether resident or non-resident of Alabama, is properly qualified to submit a proposal for this type of work in accordance with all applicable laws of the State of Alabama. Where applicable, this shall include evidence of holding a current license from the State Licensing board for General BIDDERS, Montgomery, Alabama, as required by Chapter 8 of Title 34, of the Code of Alabama, 1975. In addition, the Awarded Vendor, if non-resident of the State, and if a corporation, shall show evidence of having qualified with the Secretary of State to do business in the State of Alabama. **CONTRACTOR** must have a current business license or purchase a business license with the City of Fairhope prior to work performed. No bids shall be withdrawn for the period of thirty (30) days subsequent to the opening of proposals without the consent of the

City of Fairhope, Baldwin County, Alabama. Once completed, a tabulation of the responsive and responsible bids will be available for public viewing by visiting the following web address: www.FairhopeAL.gov.



**INVITATION TO BID
NO. 24-060-2024-PWI-002
NEW TENNIS & PICKLEBALL COURTS
AT MIKE FORD TENNIS CENTER
PROJECT NO. 2024-PWI 002**

**CITY OF FAIRHOPE
SHERRY SULLIVAN, MAYOR**

TABLE OF CONTENTS

Invitation and Instruction to Bidders.....	I
Scope of Work.....	II
Bid Response Form.....	III
Contractor Information.....	IV
Insurance.....	V
Sample Contract.....	VI
Standard Terms and Conditions.....	VII
Alabama Immigration Act Contract Requirements.....	VIII
Invitation Summary.....	IX
Bid Bond.....	X
Performance Bond.....	XI
Labor and Materials Bond.....	XII
Closeout Documents.....	XIII
Material and Equipment Specifications	Attachment
Bid Set Drawings	Attachment

**ITEM I
INVITATION AND INSTRUCTIONS TO BIDDERS**

1.00 BID INVITATION

Notice is hereby given that the **City of Fairhope (“CITY”)** will receive bids on the project described herein. Qualified **BIDDERS** are invited to bid on this CONTRACT.

1.01 BID NO.: 24-060-2024-PWI-002
NAME: New Tennis & Pickleball Courts at Mike Ford Tennis Center
LOCATION: Mike Ford Tennis Center at Stimpson Park
600 Morphy Avenue
Fairhope, AL 36532

1.02 SUMMARY

The City of Fairhope is requesting responses from qualified contractors to provide all material, equipment, labor, and incidentals for the construction of twelve (12) pickleball courts (180' x 120'), two (2) tennis courts (60' x 120' each), and the resurfacing of an existing pickleball court to a tennis court (60' x 120') bituminous asphalt courts, the layout and surfacing of twelve (12) pickleball courts and three (3) tennis courts, new court fencing (with pedestrian and utility gates), construction of concrete sidewalks, and the provision and installation of the specified court equipment. This site is currently occupied by the City's recreational tennis and pickleball facility and will remain in full operation during project construction. Work will include but is not limited to clearing and grubbing, unclassified excavation, select fill, subbase processing, processing of aggregate base, asphalt wearing course, concrete sidewalk, finished surface leveling, construction of vinyl coated chain-link fencing & gates, layout, application of acrylic coatings and installation of sports equipment.

1.03 BID DEADLINE

Bids will be received until **2:00 P.M. local time, Tuesday, August 13, 2024**, at the City Services and Public Utilities Building, 555 South Section St., Fairhope, Alabama, and publicly opened shortly thereafter.

1.04 AVAILABILITY OF DOCUMENTS

Bid Documents may be obtained on the City's website at www.FairhopeAL.gov/departments/purchasing/bids or at the City Services and Public Utilities Building, 555 South Section Street., Fairhope, Alabama. One set of Bid Documents can be obtained free of charge.

1.05 INQUIRIES

Questions or comments pertaining to this bid must be presented in writing, sent as e-mail to the attention of the Purchasing Manager, Erin Wolfe, 555 South Section St., Fairhope, AL 36532, e-mail: Purchasing@FairhopeAL.gov, by Friday, August 9, 2024, at 11:00 A.M. or will be forever waived.

1.06 SITE EXAMINATION

There will be a **MANDATORY** pre-bid meeting on Thursday, August 8, 2024, at 2:00 P.M. at the City Services and Public Utilities Building located at 555 South Section Street, Fairhope, AL. This non-mandatory pre-bid meeting will serve as an opportunity for potential bidders to engage project stakeholders, review plans and ask questions.

The City of Fairhope will not furnish any labor, material, or supplies unless specifically stated in the CONTRACT Documents. **BIDDERS** must be properly licensed to perform the work as outlined in the Scope of Work. Awarded Vendor must have a current business license or purchase a business license with the City of Fairhope prior to bid being awarded.

Except for CONTRACTS funded in whole or in part by funds received from a federal agency, preference shall be given to resident **BIDDERS** on the same basis as the nonresident **BIDDERS** state awards CONTRACT to Alabama **BIDDERS** bidding under similar circumstances. Therefore, non-resident **BIDDERS** shall submit with their bid a written opinion of an attorney at law licensed to practice law in the non-resident **BIDDERS** state of domicile as to preferences granted by that state to entities doing business in that state when letting public contracts.

1.07 **BID SECURITY**

Bids shall be accompanied by a Bid Security equal to 5% (percent) of the bid price, but in no event more than \$10,000.00. Bid Security shall be in the form of a Bid Bond or a cashier's check payable to The City of Fairhope. No Bid Security is required on bids less than \$10,000.00.

1.08 **PERFORMANCE ASSURANCE AND INSURANCE**

The **BIDDER** to whom award is made shall provide a Performance Bond equal to 100% of the CONTRACT Amount and a Labor and Material Bond equal to 50% of the CONTRACT amount.

The accepted **BIDDER** shall also provide insurance as required in ITEM V.

1.09 **DURATION OF OFFER**

Bids may be withdrawn in written or telegraphic request received from **BIDDER** prior to the time fixed for opening. No bid shall be withdrawn for a period of sixty (60) days subsequent to the opening of bids without the consent of the City Council of the City of Fairhope.

1.10 **EQUAL OPPORTUNITY**

The City of Fairhope is an Equal Opportunity Employer and requires that all **BIDDERS** comply with the Equal Employment Opportunity laws and the provisions of the CONTRACT Documents in this regard. The City of Fairhope also encourages and supports the utilization of Minority Business Enterprises on this and all public bids.

1.11 **BID SUBMISSION AND PREPARATION**

Sealed Bids, signed, executed, and dated, will be received by the City of Fairhope as noted in section 1.03 above. Submit one copy of the executed offer on the Bid Form provided, signed, and with the required Bid Security. **The bid shall be enclosed in a sealed opaque envelope approximately 9x12 inches or larger, clearly identified on the outside as a SEALED BID with the BID NAME, BID NUMBER, CITY'S NAME AND ADDRESS, CONTRACTOR'S NAME AND ADDRESS.**

Forms furnished, or copies thereof, shall be used, and strict compliance with the requirements of the invitation, these instructions, and the instructions printed on the forms is necessary. Special care should be exercised in the preparation of bids. **BIDDERS** must make their own estimates of the facilities and difficulties attending the performance of the proposed CONTRACT, including local conditions, uncertainty of weather, and all other contingencies. All designations and prices shall be fully and clearly set forth. The proper space in the bid and guaranty forms shall be suitably filled in.

Fill in all blanks on the bid form with non-erasable ink or type. Erasers or other changes must be explained or noted over the signature of the **BIDDER**.

The Bid Form may have a Contingency Allowance listed. Add this amount to the Base Bid to derive the Total Bid. The Contingency Allowance covers unforeseen conditions and shall not be used by the **BIDDER** without the written authorization of the **CITY**. At the conclusion of the project, the unused portion of the Contingency Allowance shall revert to the **CITY**.

Each bid must give the full business address of the **BIDDER** and must be signed by him with his usual signature. Bids by partnerships must furnish the full names of all partners and must be signed with the partnership name by one of the members of the partnership, or by an authorized representative, followed by the signature and designation of the person signing. Bids by corporations must be signed with the legal name of the corporation followed by the name of the State of Incorporation and by the signature and designation of the president, secretary, or other person authorized to bind it in the matter. The name of each person shall also be typed or printed below the signature. A bid by a person who affixes to this

signature the word "president," "secretary," "agent," or other designation without disclosing his principal, may be held to be the bid of the individual signing. When requested by the **CITY** satisfactory evidence of the authority of the officer signing in behalf of the corporation shall be furnished.

Each project will be bid separately unless otherwise expressly requested in the CONTRACT document. Combination bids, that is bids on separate projects lumped together as a single bid or on all or none basis, will not be accepted unless the CONTRACT document expressly requests or permits same.

1.12 **BID INELIGIBILITY**

Bids that contain irregularities of any kind may be declared unacceptable at the discretion of the **CITY**. The **CITY** may waive any irregularities and may reject any or all bids. Bids received after the deadline will be returned to the **BIDDER** unopened.

1.13 **CONTRACT TIME**

The **BIDDER** agrees to provide all material, equipment, labor, and incidentals to construct twelve (12) pickleball (180x120), two (2) tennis (60x120/each), and the resurfacing of an existing pickleball to tennis (60x120) bituminous asphalt courts, the layout and surfacing of twelve (12) pickleball and three (3) tennis courts, new court fencing (with pedestrian and utility gates), construction of concrete sidewalks and the provision and installation of the specified court equipment. It is expected that the winning bidder can complete this project in one hundred fifty (150) calendar days, no exceptions for holidays following a fifteen (15) day Notice to Proceed Period.

1.14 **INQUIRIES/ADDENDA**

All Addenda are part of the CONTRACT Documents. Include resultant costs in the Bid. Addenda will be issued by E-MAIL and posted on the City's website: www.FairhopeAL.gov. It is the responsibility of the **BIDDER** to verify that all Addenda have been received.

Questions or comments pertaining to this bid must be presented in writing, sent via email to Purchasing@FairhopeAL.gov by Friday, August 9, 2024, at 11:00 A.M. or will be forever waived.

1.15 **BID ACCEPTANCE**

Bid with lowest Total Bid amount from a responsive and responsible **BIDDER** may be accepted if within the CONTRACT Budget. In the event that alternates are listed on the Bid Form, the lowest combination of Total Bid and Alternate Bids accepted by the **CITY** shall be the accepted bid. Alternates shall be awarded in the order in which they are listed on the Bid Form.

1.16 **BIDDERS INTERESTED IN MORE THAN ONE BID**

If more than one bid is offered by any one party, by or in a name of his clerk, partner, corporation in which he has a substantial interest, or in which he is an officer, or other person, all such bids may be rejected. A party who has quoted prices on materials to a **BIDDER** is not thereby disqualified from quoting prices to other **BIDDERS** or from submitting a bid directly for the materials or work. The **CITY** reserves the right to determine in its discretion whether the provisions of this clause have been violated by any **BIDDER**.

1.17 **ERRORS IN BIDS**

BIDDERS or their authorized agents are expected to examine the maps, drawings, specifications and all other instructions pertaining to the work, which will be open to their inspection. Failure to do so will be at the **BIDDER'S** own risk. In case of error, in the extension of prices, the unit price will govern.

1.18 **CONTRACT AND BOND**

The **BIDDER** to whom award is made must, when requested, enter into written CONTRACT on the standard form as set out herein, with satisfactory security in the amount required, within the period specified, or, if no period be specified, within 15 days after the required forms are presented to him for signature.

1.19 **COLLUSION**

If there is any reason for believing that collusion exists among the **BIDDERS** any or all bids may be rejected, and those participating in such collusion may be barred from submitting bids on the same or other work with the **CITY**.

1.20 **SUBLETTING OR ASSIGNING OF CONTRACT**

Limitations: The **CONTRACTOR** shall not sublet, assign, transfer, convey, sell, or otherwise dispose of any portion of the **CONTRACT**, his right, title or interest therein, or his power to execute such **CONTRACT**, to any person, firm or corporation without written consent of the **CITY**, and such written consent shall not be construed to relieve the **BIDDER** of any responsibility for the fulfillment of the **CONTRACT**. Unless otherwise stipulated in the proposal or special provisions, the **BIDDER** shall perform with his own organization, and with the assistance of workmen under his immediate superintendence and reported on his payroll, all **CONTRACT** work of a value not less than 50 percent of the total **CONTRACT** amount, except that any items designated in the **CONTRACT** as "Specialty Items" so performed by **SUB-CONTRACT** may be deducted from the total **CONTRACT** amount before computing the amount of work required to be performed by the **BIDDER** with his own organization.

SUB-CONTRACTOR'S Status:

A **SUB-CONTRACTOR** shall be recognized only in the capacity of an employee or agent of the **CONTRACTOR** and the **CONTRACTOR** will be responsible to the **CITY** for all of the **SUB-CONTRACTOR's** work, including failures or omissions; and his removal may be required by the Project Manager, as in the case of an employee.

1.21 **PROSECUTION OF WORK**

The **BIDDER** shall prosecute the work continuously and diligently in the order and manner set out in his schedule as approved by the **CITY**. He shall provide sufficient satisfactory materials, labor, and equipment to ensure that the work will be completed in a satisfactory manner within the time specified in the **CONTRACT**.

Should the **BIDDERS** fail to maintain a satisfactory rate of progress, the **CITY** may require that additional forces and/or equipment be placed on the work to bring the project up to schedule and maintain it at that level.

Should the **BIDDER** fail to furnish sufficient satisfactory equipment and/or labor for maintaining the quality and progress of the work at satisfactory level, the **CITY** may withhold all estimates that may become due until satisfactory quality and progress are maintained; or the **CONTRACT** may be annulled.

**ITEM II
SCOPE OF WORK**

**Bid No. 24-060-2024-PWI-002
New Tennis & Pickleball Courts at Mike Ford Tennis Center
Public Works Project No. 2024-PWI 002**

SCOPE OF WORK

Project entails the “turn-key” construction of twelve (12) pickleball (180x120), two (2) tennis (60x120/each), and the resurfacing of an existing pickleball to tennis (60x120) bituminous asphalt courts, the layout and surfacing of twelve (12) pickleball and three (3) tennis courts, new court fencing (with pedestrian and utility gates), construction of concrete sidewalks and the provision and installation of the specified court equipment. This site is currently occupied by the City's recreational tennis and pickleball facility and will remain in full operation during project construction. Work will include but is not limited to clearing and grubbing, unclassified excavation, select fill, subbase processing, processing of aggregate base, asphalt wearing course, concrete sidewalk, finished surface leveling, construction of vinyl coated chain-link fencing & gates, layout, application of acrylic coatings and installation sports equipment. Bid is to include all equipment, tools, labor and materials necessary to perform the work as specified in this invitation.

1.00 GENERAL

1.01 WORK INCLUDED

- A. Clearing and grubbing
- B. Unclassified Excavation
- C. Select Fill (A-2-4 or better)
- D. Process aggregate base – to final grade and specified compaction
- E. Laydown bituminous asphalt wearing surface – to specified thickness and compaction
- F. Pressure wash and prep all new and existing asphalt pads
- G. Apply ACRYTECH™ Sports Surface (or approved equivalent) acrylic color coat system with line striping
- H. Install new fence post, mid and top rails
- I. Install new personnel and maintenance gates
- J. Install new vinyl coated chain link fencing – perimeter and court dividers
- K. Install new concrete sidewalks
- L. Minor grading for drainage
- M. Grading and top dressing of all court and sidewalk shoulders
- N. Mulch and seeding of all disturbed areas
- O. Install court divider netting
- P. Install Douglas Sports Equipment sleeves, posts and nets
- Q. Cleaning of work area

1.02 WORK NOT INCLUDED

- A. Lighting
- B. Sod replacement at court and sidewalk perimeters
- C. Any landscaping

1.03 PRODUCT DELIVERY/STORAGE AND HANDLING

- A. All surfacing materials must be delivered in the manufacturer's original container, with seals unbroken and

labels intact, with manufacturer's instructions printed thereon.

B. Store all materials in a clean dry manner, protected from damage until ready for installation.

1.04 **JOB CONDITIONS:**

Surface application temperature shall be a minimum of 50 degrees Fahrenheit and rising or a minimum of 55 degrees Fahrenheit and constant. Do not apply when surface is wet or if rain is imminent or forecasted. Protect all material from freezing. Do not store materials in direct sunlight. Containers shall be closed when not in use.

1.05 **QUALITY ASSURANCE:**

Contractor shall be approved by the surfacing materials manufacturer. Any bidder shall be a contractor regularly engaged in the construction, repair and resurfacing of tennis courts.

1.06 **SITE INSPECTION:**

All bidders are encouraged and advised to visit the site prior to submitting their bid.

1.07 **WARRANTY:**

Contractor shall provide the Owner with a one (1) year warranty against material defects in Contractor's workmanship and a one (1) year warranty from the materials manufacturer against peeling, chalking or fading.

2.00 MATERIALS

2.01 **BRAND NAME OR EQUIVALENT:**

The following Material Specifications shall be interpreted as a minimum standard of quality, and all be associated with or equivalent. Brand Name or Equivalent Specification means a specification limited to one or more items by manufacturer's names or model numbers to describe the standard of quality, performance, and other salient characteristics needed to meet the City's requirements, and which provides for the submission of equivalent products. If the Contractor opts to propose an equivalent brand, product, material or source outside this specification, then a submittal will be required.

A submittal refers to the written and/or physical information provided by a responsible contractor (i.e., contractors and subcontractors) to the general contractor. This information is submitted to the Project Manager for approval of equipment, materials, etc. before they are fabricated and delivered to the project. Submittals can be presented in various formats, such as shop drawings, cut sheets on equipment, and material samples. Submittals are required primarily for the design team to verify that the correct products and quantities will be installed on the project in compliance with the design documents/contract documents.

2.02 **APPROVED MANUFACTURERS**

A. **ACRYTECH™ Sports Surfaces**
2660 Easterly Place
Decatur, GA 30035
(770) 734-3000

B. Douglas Sports Equipment
3441 South 11th Avenue
Eldridge, Iowa 52748
(800) 553-8907

C. If intending to use a product other than those specified above, Bidder must submit complete manufacturer's product data brochures including technical specifications with their bid. Color charts and samples are required for surface materials.

2.03 SURFACING MATERIALS

A. Surface coatings - ACRYTECH™ Sports Surfaces: AT Acrylic Resurfacer, Colorguard™ Concentrate and Colored Line Paint. Colors: As selected by the Owner from manufacturer's standard colors.

B. Water – clean and fresh (potable)

C. Sand –

1. Resurfacer – Unimin 4070

2. Color Coat – Unimin 7020

2.04 COURT EQUIPMENT

A. Pickleball Net Posts - Douglas® Pickleball Premier™ XS Posts 2-7/8" Green (Item #63074) with ground sleeves – 24" PVC (GS-24PVC) (Item #63164).

B. Nets - Douglas® JTN-30 Pickleball/OS Tennis Net 36" x 21'9" (Item #20105).

C. Divider and Tennis Net Post - Douglas® Sidewinder 2-7/8" Green (Item #63001) with Ground Sleeves: 24" PVC (GS-24PVC) (Item #63164).

D. Divider and Tennis Nets - Douglas® Professional Nets TN-45 (Item # 20045).

3.00 BIDDER QUALIFICATIONS

3.01 Bidder must have ten (10) years minimum experience in court construction and resurfacing. Upon request, Bidder must present a minimum of fifteen (15) major court projects completed during the past five (5) years, as well as a list including resurfacing projects with multiple courts.

3.02 It is preferred that the Bidder be a member and hold appropriate certification from a recognized Court Builder Association such as: American Sports Builders Association (ASBA) – Certified Tennis Court Builder.

3.03 Bidder must be an approved applicator for Acrytech Surface System or for the equivalent system approved.

3.04 Bidder must be a licensed contractor in the State of Alabama.

4.00 SURFACE APPLICATION

4.01 Preparation – The new asphalt pad shall be thoroughly cleansed using a minimum of 3500 psi pressure washer in order to remove any residue from the paving process. Problem areas discovered during this process shall be brought to the attention of the Owner.

4.02 All seams, roller marks, etc. should be patched and leveled with Acrylic Resurfacer as described in Item 4.04.

4.03 All low areas must be leveled to within 1/8" with American Patch Binder. Mix 100 lbs silica sand with 2 gallons of

Portland Cement and Add Binder until desired consistency is achieved.

- 4.04 Over the Asphaltic Surface Course, apply two (2) coats of ACRYTECH™ Acrylic Resurfacer in accordance with the manufacturer's directions at a rate of not less than 0.04 – 0.06 gallons per square yard (32 – 48 gallons for 800 square yards). Dilution rate will not exceed 1 part water, 2 parts concentrate.
- 4.05 The third coat should be ACRYTECH™ Color Concentrate in accordance with the manufacturer's directions at a rate of not less than 0.03 – 0.06 gallons per square yard (24 – 48 gallons for 800 square yards). Dilution for this texture coat shall be 2 parts concentrate, 1 part water, and one part sand. (Color: Owner to select)
- 4.06 The final Finish Coat of ACRYTECH™ shall be applied as directed by the manufacturer at a rate of not less than 0.03 – 0.06 gallons per square yard (24 – 48 gallons for 800 square yards). Dilution for this texture coat shall be 2 parts concentrate, 1 part water, and one part sand. (Color: Owner to select)
- 4.07 White playing lines for tennis and blended playing lines for pickle ball, conforming to the American Sports Builders Association specifications, shall be laid out and ACRYTECH™ Textured Line Paint (100% acrylic latex) applied by brush or roller using masking tape or templates.

5.00 EQUIPMENT INSTALLATION

- 5.01 Install post sleeves in footings measuring 24" x 24", belled out to 30" and 36" in depth using 3000 PSI concrete. Tape bottom of sleeve and set sleeve 24" into the footing, plumb and level with the top of the pad or per manufacturer's specifications. (The 2' x 2' x 3' foundations are excavated for the net posts prior to the asphalt installation)
- 5.02 Set posts in sleeves with pull posts to the outside.
- 5.03 Hang nets according to manufacturer's instructions.

6.00 CLEAN UP

- 6.01 Contractor shall police his area daily and keep all debris including lunch wrappers, cups, etc. cleared and place in trash receptacles.
- 6.02 Upon completion of the project, Contractor shall remove all excess materials, trash and construction debris from the site and restore the grounds to their original condition. Owner will inspect and accept the site before final acceptance and payment is made.

COURT FENCING

As a companion Court Surface Invitation: a submitted quote to include all equipment, tools, labor and materials necessary to retrofit and install a 10-foot Vinyl Coated Chain link Fence along the perimeter of the new court. This +/- 432 linear feet of new perimeter fence shall include one (1) 3-foot personnel gate and one (1) 8-foot double swing access gate. Also, the quote shall include 116 linear feet of 8-foot tall privacy fence slats along the southern perimeter. The submitted quote shall include the cost to rehabilitate the existing perimeter fence post and top rails, including painting and repair/replacement of damaged components. In addition, the quote shall include 200 linear feet of 3-foot court divider fencing with specified top fence guard installed.

6.0 GENERAL (FENCING):

A. WORK INCLUDED (With Noted Exceptions) – Fence Construction:

- a. The Contractor shall provide all labor, materials, and appurtenances necessary for installation of the color chain link fencing system defined herein for the New Pickleball Court, including but not limited to:
 - i. Rehabbing/Replacement/Repairing of all existing fence posts and top rails
 - ii. Setting of all required posts – new, gate, infill, etc.
 - iii. Construction and Installation of all gates
 - iv. Installation of coated chain link fencing wire fabric
 - v. Installation of all connectors, brackets, bracing, ties, finials, caps, etc.
 - vi. Installation of privacy slats and fence guards
 - vii. Cleaning of work area

6.01 RELATED WORK

- A. Paving and surfacing
- B. Cast-in-place Concrete

6.02 SYSTEM DESCRIPTION

- A. The Contractor shall supply a total color chain link fencing system of the design, style and strength defined herein. The system shall include all components (i.e., framework, chain link fabric, gates and fittings) required.

6.03 QUALITY ASSURANCE

- A. The Contractor shall provide laborers and supervisors who are thoroughly familiar with the type of construction involved and materials and techniques specified.

6.04 REFERENCES

- A. American Society for Testing and Materials (ASTM) Standards: A90/A90M – Test Method for Weight (Mass) of Coating on Iron and Steel Articles with Zinc or Zinc-Alloy Coatings. A653/A653M – Specification for Steel Sheet, Zinc-Coated (Galvanized) or Zinc-Iron Alloy-Coated (Galvannealed) by the Hot-Dip Process. A924/A924M – Specification for General Requirements for Steel Sheet, Metallic-Coated by the Hot-Dip Process. B6 – Specification for Zinc. B117 – Practice for Operating Salt Spray (Fog) Apparatus. D1499 – Practice for Operating Light- and Water- Exposure Apparatus (Carbon-Arc Type) for Exposure of Plastics. D3359 – Test Methods for Measuring Adhesion by Tape Test. E8/E8M – Test Methods for Tension Testing of Metallic Materials. F567 – Practice for Installation of Chain-Link Fence. F626- Specification for Fence Fittings. F668 – Specification for Poly (Vinyl Chloride) (PVC)-Coated Steel Chain-Link Fence Fabric. F900 – Specification for Standard Colors for Polymer-Coated Chain Link Fence Materials. F934 – Specification for Standard Colors for Polymer-Coated Chain Link Fence Materials. F969 – Practice for Construction of Chain-Link Tennis Court Fence. F1043 – Specification for Strength and Protective Coatings on Metal Industrial Chain Link Fence Framework. F1184 – Specification for Industrial and Commercial Horizontal Slide Gates.
- B. American Association of State Highway and Transportation Officials (AASHTO) Standards: M181 – Standard Specification for Chain-Link Fence.
- C. United States Federal Supply Service General Services Administration Specifications: RR-F-191/3 – Federal Specification Sheet for Fencing, Wire and Post, Metal (Chain-Link Fence Posts, Top Rails and Braces) – Detail Specification.

6.05 SUBMITTAL

- A. The Manufacturer's literature shall be submitted prior to installation. Samples of fencing materials shall be provided with submittals along with color options. A total of two (2) complete packages shall be submitted.

6.06 PRODUCT HANDLING AND STORAGE

- A. Upon receipt at the job site, all materials shall be checked to ensure that no damages occurred during shipping or handling. Materials shall be stored in such a manner to ensure proper ventilation and drainage and to protect against damage, weather, vandalism, and theft. All materials regardless of state of installation shall remain the Contractor's property and responsibility until such time as final acceptance of the City of Fairhope. The City of Fairhope shall be indemnified and held harmless from any claim regarding damage to materials or installation through acts of vandalism, accident, or acts of God.

7.00 MATERIALS

7.01 MANUFACTURER

- A. Products from manufacturers having five years or more experience manufacturing fencing will be considered by the Engineer for approval in writing ten (10) days prior to execution of the contract, and they shall meet all specifications for design, sizes, and fabrication. Information regarding Manufacturer product for coated chain link fencing and color options shall be provided prior to approval of ordering materials.

7.02 MATERIAL – STEEL FRAMEWORK

- A. The steel material used to manufacture shall be zinc-coated steel strip, galvanized by the hot-dip process conforming to the criteria of ASTM A653/A653M and the general requirements of ASTM A924/A924M. Including fence post caps.
- B. The zinc used in the galvanizing process shall conform to ASTM B6. Weight of zinc shall be determined using the test method described in ASTM A90 and shall conform to the weight range allowance for ASTM A653, Designation G-90.
- C. The framework shall be manufactured in accordance with commercial standards to meet the strength (50,000 psi minimum yield strength) and coating requirements of ASTM F1043, Group IC, Electrical Resistance Welded Round Steel Pipe, light industrial weight.
- D. The exterior surface of the electrical resistance weld shall be recoated with the same type of material and thickness as the basic zinc coating.
- E. The manufactured framework shall be subjected to the coating process, a complete thermal stratification coating process (multi-stage, high-temperature, multi-layer) including, as a minimum, a six-stage pretreatment/wash (with zinc phosphate), an electrostatic spray application of an epoxy base, and a separate electrostatic spray application of a polyester finish. Including fence posts, post caps, top rails and hardware.
- F. The material used for the base coat shall be a (gray color) thermosetting epoxy; the minimum thickness of the base coat shall be two (2) mils. The material used for the finish coat shall be a thermosetting "no-mar" TGIC polyester powder; the minimum thickness of the finish coat shall be two (2) mils. The stratification coated pipe shall demonstrate the ability to endure a salt-spray resistance test in accordance with ASTM B117 without loss of adhesion for a minimum exposure time of 3,500 hours. Additionally, the coated pipe shall demonstrate the ability to withstand exposure in a weather-ometer apparatus for 1,000 hours without failure in accordance with ASTM D1499 and to show satisfactory adhesion when subjected to the cross-hatch test, Method B, in ASTM D3359. The polyester finish coat shall not crack, blister or split under normal use.
- G. The color of all frameworks shall be (specify Black, Green or Brown) in accordance with ASTM F934. City of

Fairhope shall specify color.

- H. The strength of fencing shall conform to the requirements of ASTM F1043; the minimum weight shall not be less than 90% of the nominal weight (see Table 1). The strength of line, end, corner and pull posts shall be determined by the use of 4' or 6' cantilevered beam test. The top rail shall be determined by a 10' free-supported beam test (see Table 1). An alternative method of determining pipe strength is by the calculation of bending moment (see Table 1). Conformance with this specification can be demonstrated by measuring the yield strength of a randomly selected piece of pipe from each lot and calculating the section modulus. The yield strength shall be determined according to the methods described in ASTM E8. For materials under this specification, the 0.2 offset method shall be used in determining yield strength. Terminal posts, line posts and top/bottom rails shall be precut to specified lengths.

7.03 MATERIAL – FENCE FABRIC

- A. The material for chain link fence fabric shall be manufactured from galvanized steel wire. The weight of zinc shall meet the requirements of ASTM F668, Table 4. Galvanized wire shall be PVC-coated to meet the requirements of ASTM F668. The class of the fence fabric shall be (specify Class 1 - Extruded, Class 2A - Extruded and Bonded or Class 2B - Fused and Bonded).
- B. Selvage: Top edge shall be knuckled, and bottom edge shall be knuckled.
- C. Color: The coating color for the fence fabric shall be (specify Black, Green or Brown). Reference ASTM F668 and ASTM F934. Color to be approved by the City of Fairhope prior to ordering of materials.
- D. Wire Size: The size of the steel wire core shall be 8 gauge and the finished size of the coated wire shall be 0.162 inches.
- E. Height and Mesh Size: The fabric height shall be as shown on construction plan (10 feet) high with a mesh size of 2 inches – no other size shall be considered by the City of Fairhope.

7.04 MATERIAL – FENCE FITTINGS

- A. The material for fence fittings shall be manufactured to meet the requirements of ASTM F626. The coating for all fittings shall be the same color coating system required for the framework (see 2.02); the color of all fittings and fasteners shall be (specify Black, Green or Brown) in accordance with ASTM F934. All fasteners shall be stainless steel.

7.05 MATERIAL – GATES

- A. Swing gates shall be manufactured and coated to meet the requirements of ASTM F900. Slide gates shall be manufactured to meet the requirements of ASTM F1184. The color of all gates shall be (specify Black, Green or Brown) in accordance with ASTM F934. Color to be specified by the City of Fairhope.

7.06 MATERIAL – FENCE SLATS

- A. Fence Slats shall be FENPRO – 3000 Series Fence Slats (Single Wall Bottom Locking) (or equivalent) – 8-foot tall (as measured from the fence bottom and slats shall run the entire southern perimeter (including chamfers) – 116 linear feet. Color: Emerald Green

8.00 EXECUTION

8.01 PREPARATION

- A. All new installation shall be laid out by the Contractor in accordance with the construction plan.

8.02 INSTALLATION

- A. Install chain link fence in accordance with ASTM F567. Fence posts shall be set at spacings of a maximum of 10' O.C. Gate posts shall be spaced according to the gate openings specified in the construction plans. The Contractor shall submit post base placement and material requirements for review and approval by the Public Works Director. Install fabric on security side and attach with 9 gauge coated steel wire ties to line posts at 15 inches O.C., within 4 inch of top and bottom of fabric, to rails, braces and tension wire at 24 inches O.C. using 9 gauge steel clips (hog rings).

8.03 CLEANING

- A. The Contractor shall clean the jobsite of excess materials. Post hole excavations shall be scattered uniformly away from posts or removed.

TABLE 1

Fence Industry	Decimal O.D. Equivalent		Pipe Wall Thickness		Weight		Section Modulus Inches	x	Min. Yield Strength psi	=	Max. Bending Moment lb. in.	Calculated Load (lbs.)		
	O.D. Inches	(mm)	Inches	(mm)	lb./ft.	(kg/m)						10' Free Supported	Cantilever	
												4'	6'	
1-3/8"	1.315	33.40	.080	2.03	1.06	1.57	.0900	x	50,000	=	4,500	150	N/A	N/A
1-5/8"	1.660	42.16	.085	2.16	1.43	2.13	.1574	x	50,000	=	7,870	262	164	109
2"	1.900	48.26	.090	2.29	1.74	2.59	.2208	x	50,000	=	11,040	N/A	230	154
2-1/2"	2.375	60.33	.095	2.41	2.32	3.45	.3734	x	50,000	=	18,670	N/A	389	259
3"	2.875	73.03	.111	2.82	3.26	4.85	.6365	x	50,000	=	31,825	N/A	663	442

TABLE 2

Finished Gauge	Finished OD (NOM)	Core Diameter (NOM)	PVC Coating Thickness	Mesh Sizes Available	Fabric Extrusion Type	Minimum Breaking Strength
8	.162 (4.11 mm)	.120 (3.05 mm)	.015 - .025 (0.38 - 0.64 mm)	2 (50 mm); 1-3/4 (44 mm); 1 (25 mm)	CLASS 1, 2A	850#
9	.148 (3.76 mm)	.097 (2.46 mm)	.015 - .025 (0.38 - 0.64 mm)	2 (50 mm); 1-3/4 (44 mm); 1-1/4 (32 mm); 1 (25 mm)	CLASS 1, 2A	650#

SUBGRADE AND BASE NOTES:

1. North courts will involve unclassified excavation and fill sections.
2. Upon clearing and grubbing and cut back to subgrade, it shall be inspected and determined if any additional cut is required. It is suspected that the in-situ material is suitable to place structural fill and/or aggregate for court build up.
3. Existing fill, if required, shall be replaced as directed by the Project Engineer.
4. Soil removed from cut sections may be used as part of the pad fill in the court areas if first approved by the City Engineer.
5. Select fill (also called "structural fill") shall be in accordance with the requirements of the City of Fairhope. No colored (staining) soils are allowed in the coastal zone.
6. Select fill shall be classified as an A-2-4 (or better) in the AASHTO system.
7. Field density shall be met for the subgrade below the fill and each list including, but not limited to, flatwork areas such as driveways and patios. All subgrade and fill shall be compacted with a plate tamper and proofed to show proper compaction has been met. Obtain a minimum density of 95% of the maximum dry density as determined by FM 1 T-180.

CRITICAL TIMELINES:

- 15-day Notice to Proceed Period
- One Hundred Fifty (150) calendar days (including thirty (30) calendar days for asphalt cure time prior to placement of acrylic surfaces) from the Notice to Proceed date allowed for work (no exceptions for holidays).
- Contractor is not limited to time of day or days of the week restrictions on this project – site available 24/7.

GENERAL NOTES:

1. Contractor will be required to be licensed, Bonded, and Insured. Documents will be required at time of bid/quote acceptance and issuance of purchase order.
2. Work must be completed One Hundred Fifty (150) calendar days from the end of “Notice to Proceed” period.
3. Enclosed scope of work, descriptions, quantities, etc. are “good faith” estimates only. Prior to submitting quotations, Contractor should field measure and verify all quantities.
4. Bid Response will be treated and considered as “lump sum” bids for all described work.
5. Bid Responses are subject to the GENERAL CONDITIONS, SPECIAL PROVISIONS and SUPPLEMENTAL SPECIFICATIONS as attached.
6. LIQUIDATED DAMAGES: Liquidated Damages (LD's) shall be applied to this contract. The Liquidated Damages Daily Charge of \$250.00/calendar day will apply.

GENERAL CONDITIONS, SPECIAL PROVISIONS and SUPPLEMENTAL SPECIFICATIONS

stipulates to pay to the Owner a sum to be determined and fixed by the Owner in an amount not less than five hundred (\$500.00) dollars nor more than twenty (20%) percent of the gross amount of the Contract in the event he or any subcontractor breach this agreement to use domestic products.

8. **EDGE OF PAVEMENT & CONCRET SHOULDER RESTORATION:** This work shall include furnishing all labor, equipment, materials and all incidentals necessary to restore the new edge of pavement & concrete/shoulder post the wearing asphalt overlay and walkway construction. This work shall include placement of topsoil, hand grading (to ensure drainage), dressing and stabilization with seed & mulch post paving. The cost of this shoulder preparation shall be a subsidiary obligation of the court construction.
9. **PUBLIC CONVENIENCE:** No attempt is made to restrict work hours of the Contractor's operations, but he is reminded that it will be necessary to arrange his work schedule to provide the least inconvenience to the public and individual residents. The Contractor shall take extra precaution to insure that traffic is protected by the use of, but not limited to, flashing signs and barrels. No direct payment will be made for any of the work described in this section.
10. **EROSION CONTROL:** Immediately prior to any clearing and grubbing or any excavation which could disturb the soils, the Contractor shall install the erosion control items in locations as required by the nature of the work performed.

The Contractor will be responsible for identifying and installing erosion control in areas where erosion may be encountered during construction of the project. The Contractor shall take all necessary precautions to insure that the construction of the project and the erosion/sediment from the project are adequately controlled and do not damage streams or adjacent property.

The erosion control items installed shall be maintained by the Contractor throughout the course of the project. The City of Fairhope's Code Enforcement Officer shall be the final authority for corrective action, remediation, requirement of additional BMP's and all other directives required for erosion/sediment control. The cost of erosion control measures and BMP's shall be a subsidiary obligation of the court construction.

11. **UNDERGROUND UTILITIES AND SERVICES:** Existing utilities, mailboxes, signs and minor obstructions are not shown on the plans. Their presence, and the required removal and the resetting thereof shall be considered incidental to the overall project and the cost for the work noted above shall be included in the overall "lump sum" price for the project (no separate payment).

The Contractor is solely responsible for the locating all existing Utilities and Services. Failure of the Contractor to locate any utility does not justify additional payment to the Contractor if said utility is damaged. The Contractor must notify the utility companies involved prior to starting construction and shall make every effort not to damage any utilities. If utilities are damaged by the Contractor, the Contractor must pay all expenses incurred in the repair at no cost to the Owner or his representatives.

12. **PROVISIONS REQUIRED BY LAW DEEMED INSERTED:** Each and every provision of law and clause required by law to be inserted in this contract shall be deemed to be inserted herein and the contract shall be read and enforced as though it were included herein, and if through mistake or otherwise any such provision is not inserted, or is not correctly inserted, then upon the application of either party the contract shall forthwith be physically amended to make such insertion or correction.
13. **PROTECTION OF LIVES AND HEALTH:** "The Contractor shall exercise proper precaution at all times for the protection of persons and property and shall be responsible for all damages to

GENERAL CONDITIONS, SPECIAL PROVISIONS and SUPPLEMENTAL SPECIFICATIONS

persons or property, either on or off the site, which occur as a result of his prosecution of the work. The safety provisions of applicable laws and building and construction codes, in addition to specific safety and health regulations described by Chapter XIII, Bureau of Labor Standards, Department of Labor, Part 1518, Safety and Health Regulations for Construction, as outlined in the Federal Register, Volume 36, No. 75, Saturday, April 17, 1971. Title 29 - LABOR, shall be observed and the Contractor shall take or cause to be taken, such additional safety and health measures as the Contracting Authority may determine to be reasonably necessary."

14. **CITY ENGINEER'S AUTHORITY:** The City Engineer shall give all orders and directions contemplated under this contract and specifications, relative to the execution of the work. The City Engineer shall determine the amount, quality, acceptability, and fitness of the several kinds of work and materials which are to be paid for under this contract and shall decide all questions which may arise in relation to said work and the construction thereof. The City Engineer's estimates and decisions shall be final and conclusive, except as herein otherwise expressly provided. In case any question shall arise between the parties hereto relative to said contract or specifications, the determination or decision of the City Engineer's shall be a condition precedent to the right of the Contractor to receive any money or payment for work under this contract affected in any manner or to any extent by such question.

The City Engineer shall decide the meaning and intent of any portion of the specifications and of any plans or drawings where the same may be found obscure or be in dispute. Any differences or conflicts in regard to their work which may arise between the Contractor under this contract and other Contractors performing work for the Owner shall be adjusted and determined by the City Engineer.

15. **USE OF PREMISES AND REMOVAL OF DEBRIS:** The Contractor expressly undertakes at his own expense:
- a. to take every precaution against injuries to persons or damage to property;
 - b. to store his apparatus, materials, supplies and equipment in such orderly fashion at the site of the work as will not unduly interfere with the progress of his work or the work of any other contractors;
 - c. to place upon the work or any part thereof only such loads as are consistent with the safety of that portion of the work; materials, and debris caused by his operations, to the end that at all times the site of the work shall present a neat, orderly and workmanlike appearance;
 - d. before final payment to remove all surplus material, false-work, temporary structures, including foundations thereof, plant of any description and debris of every nature resulting from his operations, and to put the site in a neat, orderly condition;
 - e. to effect all cutting, fitting or patching of his work required to make the same to conform to the plans and specifications and, except with the consent of the City Engineer, not to cut or otherwise alter the work of any other Contractor.

16. **MATERIALS, SERVICES AND FACILITIES:**

- a. It is understood that except as otherwise specifically stated in the Contract Documents, the Contractor shall provide and pay for all materials, labor, tools, equipment, water, light, power, transportation, supervision, temporary construction of every nature, and all other services and facilities of every nature whatsoever necessary to execute, complete and deliver the work within the specified time.
- b. Any work necessary to be performed after regular working hours, on Sundays or Legal Holidays, shall be performed without additional expense to the Owner.

17. **CONTRACTOR'S TITLE TO MATERIALS:** No materials or supplies for the work shall be purchased by the Contractor or by any Subcontractor subject to any chattel mortgage or under a conditional sale contract or other agreement by which an interest is retained by the seller. The

GENERAL CONDITIONS, SPECIAL PROVISIONS and SUPPLEMENTAL SPECIFICATIONS

Contractor warrants that he has good title to all materials and supplies used by him in the work, free from all liens, claims or encumbrances.

18. INSPECTION AND TESTING OF MATERIALS:

- a. All materials and equipment used in the construction of the project shall be subject to adequate inspection and testing in accordance with accepted standards. The laboratory or inspection agency shall be selected by the Owner. The Owner will pay for all laboratory inspection service direct, and not as a part of the contract.
- b. Materials of construction, particularly those upon which the strength and durability of the structure may depend, shall be subject to inspection and testing to establish conformance with specification and suitability for uses intended.

19. CONTRACT TIME: Contract time for the Construction of New Tennis & Pickleball Courts at Mike Ford Tennis Center, PROJECT: City of Fairhope Public Works Project No. 2024 PW-002 shall be ***one hundred and fifty (150) calendar days (including 30 calendar days for asphalt cure time prior to placement of acrylic surfaces)***. Contract time shall start fifteen (15) days following the Official Notice to Proceed to Proceed.

20. LIQUIDATED DAMAGES (LD's): Liquidated Damages (LD's) shall apply. LD's shall be calculated at a fixed rate of \$250.00 per calendar day beyond the designated contract time.

**ITEM III
BID RESPONSE FORM**

Date: ____ / ____ / ____

Bid No: 24-060-2024-PWI-002 New Tennis & Pickleball Courts at Mike Ford Tennis Center

Bids Due: Tuesday, August 13, 2024, 2:00 P.M.

BID RESPONSE:

1. **Lump Sum Price – Including Material, Equipment, Tools, Labor, Overhead, Profit and Incidentals to deliver a complete New Tennis & Pickleball Courts, resurface existing court and All associated appurtenances at the Mike Ford Tennis Center (per the Plans and Enclosed Specifications):**
\$ _____

2. **Project Contingency for Unforeseen Conditions (5% of Base Bid Above):**
\$ _____

3. **Base Bid Total (Lump Sum):**
\$ _____

Bid will include all labor, materials, equipment, shipping and postage, overhead, profit, bonds, insurance and all other costs necessary to provide the complete services outlined within this CONTRACT and scope of work.

Receipt of the following Addenda to these documents is hereby acknowledged by the undersigned (CONTRACTOR to complete below):

ADDENDUM NO.	DATE ISSUED	ADDENDUM NO.	DATE ISSUED
_____	_____	_____	_____
_____	_____	_____	_____

Each bid must give the full business address of the CONTRACTOR and must be signed by him with his usual signature. Bids by partnerships must furnish the full names of all partners and must be signed with the partnership name by one of the members of the partnership, or by an authorized representative, followed by the signature and designation of the person signing. Bids by corporations must be signed with the legal name of the corporation followed by the name of the State of Incorporation and by the signature and designation of the president, secretary, or other person authorized to bind it in the matter. The name of each person shall also be typed or printed below the signature. A bid by a person who affixes to this signature the word "president," "secretary," "agent," or other designation without disclosing his principal, may be held to be the bid of the individual signing. When requested by the City of Fairhope, Baldwin County, Alabama, satisfactory evidence of the authority of the officer signing in behalf of the corporation shall be furnished.

The undersigned agrees to furnish the goods/services as requested by you for the City of Fairhope, Baldwin County, Alabama in your invitation to bid, and certifies that they will meet or exceed the specifications called for. The undersigned has read all information pertaining to this bid and has resolved all questions. It is also understood and agreed that all prices quoted are F.O.B. described in the bid documents and specifications. The undersigned also affirms he/she has not been in any CONTRACT or collusion among BIDDERS or prospective BIDDERS in restraint of freedom of competition, by CONTRACT to bid at a fixed price or to refrain from bidding or otherwise.

Witness our hands and seals this _____ day of _____, 2024.

If Individual or Partnership

(Name of Individual or Partnership)

(Name of Partner Print)

(Name of Representative Authorized to sign Bids and CONTRACTs for the firm Print)

(Name of Partner Print)

Address _____

Phone Number () _____ Fax Number () _____

E-mail address _____ Alabama Contractor's License No. _____

Foreign Entity ID (if outside of Alabama) _____

If Corporation or LLC

Company _____

State of Incorporation _____

Company Representative _____
(Representative Authorized to sign Bids and CONTRACTs for the firm Print)

Company Representative _____
(Representative Authorized to sign Bids and CONTRACTs for the firm Signature)

Address _____

Phone Number () _____ Fax Number(____) _____

E-mail address _____ AL Contractor's License No. _____

Foreign Vendor Id _____

BID PROPOSAL NOTARIZATION:

STATE OF _____ }

COUNTY OF _____ }

I, the undersigned authority in and for said State and County, hereby certify that _____,
as _____ respectively, of _____, whose name is signed to
the foregoing document and who is known to me, acknowledged before me on this day, that, being informed of the contents
of the document they executed the same voluntarily on the day the same bears date.

Given under my hand and Notary Seal on this _____ day of _____, 2024.

NOTARY PUBLIC _____

MY COMMISSION EXPIRES ____/____/____

**ITEM IV
CONTRACTOR INFORMATION**

This Section must be printed, completed, and turned in with your bid response to

**Bid No. 24-060-2024-PWI-002
New Tennis & Pickleball Courts at Mike Ford Tennis Center
Public Works Project No. 2024-PWI 002**

Business Organization

Name of CONTRACTOR (exactly as it appears on W-9):

Doing-Business-As Name of CONTRACTOR:

Principal Office Address:

LOCAL Telephone Number: _____ **Toll- Free** _____
LOCAL Fax Number: _____
Email address: _____
Website: _____

Form of Business Entity [check one ("X")]

Corporation _____
Partnership _____
Individual _____
Joint Venture _____
Other (describe): _____

Corporation Statement

If a corporation, answer the following:

Date of incorporation: _____

Location of incorporation: _____

The corporation is held: Publicly ___
Privately ___

Partnership Statement

If a partnership, answer the following:

Date of organization: _____

Location of organization: _____

The partnership is: General ___
Limited ___

Joint Venture Statement

If a Joint Venture, answer the following:

Date of organization: _____

Location of organization: _____

JV CONTRACT recorded? Yes ___ No ___

Contact: _____ Email _____

Phone _____ Fax _____

END OF CONTRACTOR INFORMATION SECTION

3.07 **Automobile Liability**

Covering all Owned, Non-Owned, and Hired vehicles with a limit of no less than \$1,000,000 combined single limit of Bodily Injury and property damage per occurrence.

3.08 **Certificate of Insurance**

A Certificate of Insurance evidencing the above minimum requirements must be provided to and accepted by the City PRIOR to commencement of any work on the CONTRACT. Each policy shall be endorsed to provide ten (10) days written notice of cancellation to the CITY

Such insurance as is afforded by the above policies covers the operations undertaken by the insured with respect to the construction of the project above designated. The insurance afforded by the above designated policies, specimen copies of which have been filed with the **CITY**, and to each of which is attached for following endorsement.

The insurer agrees with the insured as follows:

1. That it will furnish to said City of Fairhope a certificate of insurance in triplicate on a form approved for such purpose by said **CITY**, setting forth the pertinent information regarding the policy to which this endorsement is attached, for each project of said **CITY** to which the policy applies.
2. That it will attach to each said certificate of insurance executed copies of any endorsement other than this endorsement which are attached to said policy at the time said policy is issued, provided only that said endorsements affect the coverage of said policy in respect of operations involved in the construction of the projects of said **CITY** to which the policy applies.
3. That it will mail to the City Council of the City of Fairhope three executed copies of each endorsement subsequently issued to become a part of said policy provided only that endorsement affects the coverages of said policy in respect of operations involved in the construction of the project of said **CITY** which the policy applies, and provided further that such endorsement shall not be effective unless such notice is given to the **CITY** at the same time that notice thereof is given to the insured.
4. That it will mail to the City Council of the **CITY** of Fairhope at least ten days before the effective date thereof notice of cancellation of said policy, provided no cancellation shall be effective unless such notice is given to the **CITY**.

END OF INSURANCE REQUIREMENTS

ITEM VI



City of Fairhope
CONTRACT

This **CONTRACT** is made this _____ day of _____, 202___, by and between the City of Fairhope (hereinafter referred to as the "**OWNER**") and _____ (hereinafter referred to as the "**CONTRACTOR**"), for

Bid Number/Name

The **OWNER** and the **CONTRACTOR** agree as set forth below:

1. The **CONTRACT** consists of all the items contained within this **CONTRACT**, The Proposal Package, Proposal, Scope of Work and Specifications, drawings (if applicable), Addenda, Amendments, and City of Fairhope Standard Terms and Conditions, which are attached hereto and made a part hereof, as if fully contained herein; for the performance of all work and the furnishing of all labor and materials required for completion of the **WORK**.
2. The **CONTRACTOR** shall perform all the **WORK** described herein.
3. The **WORK** to be performed under this **CONTRACT** shall be commenced upon execution of this **CONTRACT** within number (DAYS) days of the date specified in the *Notice to Proceed* (NTP) to be issued to the **CONTRACTOR** by the **OWNER**, or its authorized representative. The work shall be completed, subject to authorized adjustments, within (DAYS) consecutive calendar days from and after the commencement date stipulated in said *Notice to Proceed*. Liquidated damages for non-completion of the work within this time limit will be assessed at the rate of (DOLLARS) per working day.
4. The **OWNER** shall pay the **CONTRACTOR** in current funds for the performance of the **WORK**, the **CONTRACT SUM** of _____ DOLLARS (\$ _____). This represents a **LUMP SUM** payment for performance of the **WORK**, which payment shall be issued after the Contract is fully performed and the **OWNER** has inspected the **WORK**.
5. **General Conditions**
 - a. **Indemnity:** The **CONTRACTOR** hereby agrees to indemnify and save harmless the **OWNER**, its officers, agent, and employees, from and against any and all liabilities, claims, demands, damages, fines, fees, expenses, penalties, suits, proceedings, actions and cost of actions, including reasonable attorneys' fees for trial and on appeal, of any kind and nature, arising or growing out of, or in any way connected with the performance of this **CONTRACT**, to the extent caused by a negligent act or omission of the **CONTRACTOR**, their agents, servants, employees, **SUB-CONTRACTORS**, or others associated with the **CONTRACTOR**. The **CONTRACTOR** shall be responsible for damage to any elevator equipment excluded from this agreement, or damage or injury caused by any equipment excluded from this agreement, to the extent that the damage or injury is caused by a negligent act or omission of the **CONTRACTOR**.
 - b. **Notification and Accident Reports:** In the event of accidents of any kind, the **CONTRACTOR** shall notify the **OWNER** immediately and furnish, without delay, copies of all such accident reports to the **OWNER**. If in the performance of their Work, the **CONTRACTOR** fails to immediately report an accident to the **OWNER**, of which the **CONTRACTOR** has knowledge of and which results in a fine

levied against the **OWNER** then the **CONTRACTOR** shall be responsible for all fines levied against the **OWNER**.

6. Termination of Agreement

- a. Termination for Default: Performance of Work under this Agreement may be terminated by the **OWNER**, in whole or in part, in writing, whenever the **OWNER** determines that the **CONTRACTOR** has failed to meet the requirements of this Agreement.
 - i. The Owner has a right to terminate for default if the contractor fails to make delivery of material or does not perform the work, or if the Contractor fails to perform the Work within the time specified in the Agreement, or if the Contractor fails to perform any other provision of the Agreement.
 - ii. Failure on the part of the Contractor to deliver or perform the Work within the time specified, or within a reasonable time as determined by the Owner, or failure on the part of the Contractor to make replacements of rejected articles, or Work when so requested, immediately or as directed by the Owner, shall constitute authority for the Owner to purchase in the open market, articles or Work of comparable grade to replace the articles or Work rejected, not delivered or completed. On all such purchases, the Contractor shall reimburse the Owner within a reasonable time specified by the Owner for any expense incurred in excess of Agreement prices.
 - iii. Such purchases shall be deducted from the Agreement sum. If public necessity demands it, the Owner reserves the right to utilize services or use and/or consume articles delivered, which are standard in quality, subject to an adjustment of price to be determined by the Owner.
- b. Termination for Convenience: The **OWNER** has the absolute right to terminate the Agreement upon "Award of Contract" another **CONTRACTOR**, to perform work referenced herein. In such event, payment of the monthly contract fee shall cease on the date of cancellation of the **CONTRACT** by the **OWNER**.

7. Warranty

- a. The **CONTRACTOR** warrants that the Work including equipment and materials provided shall conform to the professional standards of care and practice in effect at the time the Work is performed, be of the highest quality, and be free from all faults, defects, or errors. If the **CONTRACTOR** is notified in writing of a fault, deficiency or error in the Work, the **CONTRACTOR** shall at the **OWNER**'s option, either re-perform such portions of the Work to correct such fault, defect, or error, at no additional cost to the **OWNER**, or refund to the **OWNER** the charge paid by the **OWNER**, which is attributable to such portions of the faulty, defective or erroneous Work, including costs for re-performance or Work provided by other **CONTRACTORS**. All equipment and materials provided by the **CONTRACTOR** shall be merchantable and for the purpose intended and meet all industry quality standards.

8. Time of Completion

The **OWNER** and **CONTRACTOR** understand and agree that time is of the essence in the performance of this Agreement. The **CONTRACTOR** or **OWNER**, respectively, shall not be liable for any loss or damage, resulting from any delay or failure to perform its contractual obligations within the time specified, due to acts of God, actions or regulations by any governmental entity or representative, strikes, fire, water damage, loss of power, loss of funding or any other causes, contingencies, or circumstances not subject to the **OWNER** or **CONTRACTOR**'S control, respectively, whether of a similar or dissimilar nature, which prevent or hinder the performance of the **OWNER**'S or **CONTRACTOR**'S contractual obligations, respectively. Any such causes of delay, even though existing on the date of the **CONTRACT**, or on the day

of the start of Work, shall extend the time of the OWNER'S or CONTRACTOR'S performance respectively, by the length of the delays occasioned thereby, including delays reasonably incident to the resumption of normal Work schedules.

However, under such circumstances as described herein, the OWNER may, at their discretion, cancel this CONTRACT for their own convenience.

9. Insurance Requirements

See **ATTACHMENT B**

10. Acceptance of Work

The OWNER will be deemed to have accepted the Work after the OWNER agrees the Work is completed. In the event Work furnished under the CONTRACT is found to be defective or does not conform to the intent of the CONTRACT, the CONTRACTOR shall, within ten (10) days from receipt of notice from the OWNER, correct the deficiencies. Failure on the part of the CONTRACTOR to properly correct the deficiencies within the time period allowed will constitute the OWNER'S right to cancel the CONTRACT immediately, upon written notice to the CONTRACTOR.

11. Correction of Work

The CONTRACTOR shall promptly correct all Work rejected by the OWNER as faulty, defective or failing to conform to the CONTRACT, whether observed before or after completion of the Work. The CONTRACTOR shall bear all costs of correcting such rejected Work.

12. Right to Audit

The CONTRACTOR shall maintain documentation of all work performed. The CONTRACTOR shall make any and all documentation available to the OWNER at all reasonable times, for inspections and audit by the OWNER, during the entire term of the CONTRACT, and for a period of three (3) years after the expiration of this CONTRACT.

13. CONTRACT Rights and Remedies

The CONTRACTOR shall maintain documentation of all work performed. The CONTRACTOR shall make any and all documentation available to the OWNER at all reasonable times, for inspections and audit by the OWNER, during the entire term of the CONTRACT, and for a period of three (3) years after the expiration of this CONTRACT.

14. Time is of the Essence

The Owner and CONTRACTOR agree that time is of the essence in the performance of Work called for under this CONTRACT. The CONTRACTOR agrees that all work will be accomplished regularly, diligently and uninterrupted at such a rate of progress as will ensure full completion thereof within reasonable time periods.

15. Safety Measures

The CONTRACTOR shall take all necessary precautions for the safety of the OWNER'S and CONTRACTOR'S employees at the Work site, and shall erect and properly maintain at all times, all necessary safeguards for the protection of the workmen and the public. The CONTRACTOR shall post signs warning against hazards in and around the Work site.

16. Extra Work and Associated Costs

- a. Changes in the Work: The OWNER, without invalidating the CONTRACT, may order changes in the Work within the general scope of this CONTRACT, consisting of additions, deletions, or other revision, the CONTRACT price and time for execution of the Work being adjusted accordingly.
- b. All such changes in the Work shall be authorized by a written Amendment to the CONTRACT or a separate Change Order and shall be executed under the applicable conditions of the CONTRACT.

17. Familiarity with the Work

The CONTRACTOR, by executing this CONTRACT, acknowledges full understanding of the extent and character of the Work required and the conditions surrounding the performance thereof. The OWNER will not be responsible for any alleged misunderstanding of conditions surrounding the performance thereof. It is understood that execution of the CONTRACT by the CONTRACTOR serves as his stated commitment to fulfill all requirements and conditions referred to in this CONTRACT.

18. Scope of Work

See **ATTACHMENT B**

19. Contractor Liability

Nothing in this CONTRACT shall be construed to mean that the CONTRACTOR assumes any liability for damages or otherwise, on account of accidents to persons or property, except those resulting from negligence on the part of the CONTRACTOR or its agents, servants, employees, and subcontractors.

20. Miscellaneous Provisions

- a. The CONTRACTOR shall not employ SUB-CONTRACTORS without the express written permission of the OWNER.
- b. The CONTRACTOR shall not assign the CONTRACT or sublet it as a whole without the express written permission of the OWNER. The OWNER may assign the CONTRACT, or sublet it as a whole, without the consent of the CONTRACTOR.
- c. No waiver, alteration, consent, or modification of any of the provisions of the CONTRACT shall be binding unless in writing and signed by the OWNER and CONTRACTOR.
- d. The CONTRACTOR is to procure all permits, licenses, and certificates, or any approvals of plans or specifications as may be required by Federal, State, Local Laws, ordinances, rules, and regulations, for the proper execution and completion of Work covered under this CONTRACT.
- e. The CONTRACTOR shall at all times keep the Work area free from accumulation of waste materials or rubbish caused by his operations, and promptly remove any such materials to an area designated by the OWNER or remove to a waste site as directed by the OWNER. If the CONTRACTOR fails to clean up the Work site, the OWNER will complete the task and charge the CONTRACTOR for such services.
- f. This CONTRACT is considered a non-exclusive Agreement between the parties.
- g. This CONTRACT is deemed to be under and shall be governed by and construed according to the laws of the State of Alabama.
- h. Any litigation arising out of the CONTRACT shall be heard in the Courts of Baldwin County, Alabama.

- i. This CONTRACT contains all terms and conditions agreed upon by the OWNER and CONTRACTOR. No other agreement, oral or otherwise, regarding the subject matter of this CONTRACT shall be deemed to exist or to bind either party hereto.
- j. This CONTRACT shall not be construed against the party or parties preparing it. It shall be construed as if all the parties and each of them jointly prepared this CONTRACT, and any uncertainty or ambiguity shall not be interpreted against one or more parties.

Section 41-16-5, Code of Alabama 1975, requires that public contracts over \$15,000 include the following language:

**By signing this Contract, _____ represents and agrees

 COMPANY NAME
 that it is not currently engaged in, nor will it engage in, any boycott of a person or entity based in or doing
 business with a jurisdiction with which the State of Alabama can enjoy open trade**

IN WITNESS WHEREFORE, the parties hereto have executed this **CONTRACT** as of the day and year first above written.

THE CITY OF FAIRHOPE, ALABAMA

Sherry Sullivan, Mayor

ATTEST:

Lisa A. Hanks, MMC, City Clerk

NOTARY FOR OWNER (CITY OF FAIRHOPE)

STATE OF ALABAMA _____ }
 COUNTY OF BALDWIN _____ }

I, the undersigned authority in and for said State and County, hereby certify that SHERRY SULLIVAN, Mayor of the City of Fairhope whose name is signed to the foregoing document and who is known to me, acknowledged before me on this day, that, being informed of the contents of the document she executed the same voluntarily on the date the same bears date.

Given under my hand and Notary Seal on this _____ day of _____, 202__.

NOTARY PUBLIC _____

MY COMMISSION EXPIRES _____

IF INDIVIDUAL OR PARTNERSHIP

Individual or Partnership

Print Name of Partner

Print Name of Representative Authorized to Sign
Contracts for the firm

Print Name of Partner

Signature of Representative Authorized to Sign
Contracts for the firm

Print Name of Partner

Address

Address

City, State, Zip Code

Phone Number

Fax Number

Primary E-mail Address

AL General Contractor License No. (Attach Copy)

AL General Contractor License Major Categories

AL General Contractor Specialties

AL Foreign Corporation Entity ID (Required of Out of State Vendors)

IF CORPORATION OR LLC

Company

State of Incorporation

Company Representative

Print Name of Representative Authorized to Sign
Contracts for the firm

Signature of Representative Authorized to Sign
Contracts for the firm

Address

Address

City, State, Zip Code

Phone Number

Fax Number

Primary E-mail Address

AL General Contractor License No. (Attach Copy)

AL General Contractor License Major Categories

AL General Contractor Specialties

AL Foreign Corporation Entity ID (Required of Out of State Vendors)

NOTARY FOR INDIVIDUAL, PARTNERSHIP, CORPORATION, OR LLC

STATE OF _____ }
COUNTY OF _____ }

I, the undersigned authority in and for said State and County, hereby certify that _____ As
Name

_____ respectively of _____
Title Company Name

Whose name is signed in the foregoing document and who is known to me, acknowledged before me on this day, being informed of the contents of the document they executed the same voluntarily on the day the same bears date.

Given under my hand and Notary Seal on this _____ day of _____, 202__.

NOTARY PUBLIC _____

MY COMMISSION EXPIRES _____



ITEM VII

CITY OF FAIRHOPE

STANDARD TERMS AND CONDITIONS

1. ACCEPTANCE OF AGREEMENT

This Agreement contains all terms and conditions agreed upon by the Owner and Winning bidder. No other agreement, oral or otherwise, regarding the subject matter of this Agreement shall be deemed to exist or to bind either party hereto. The Winning Bidder shall not employ Subcontractors without the express written permission of the Owner. No waiver, alteration, consent or modification of any of the provisions of the Agreement shall be binding unless in writing and signed by the Owner and Contractor. This Agreement shall not be construed against the party or parties preparing it. It shall be construed as if all the parties and each of them jointly prepared this Agreement, and any uncertainty or ambiguity shall not be interpreted against one or more parties.

2. ACCEPTANCE OF WORK

The City of Fairhope will be deemed to have accepted the Work after the City of Fairhope agrees the Work is completed by signature on delivery or service tickets. In the event Work furnished under the Contract / Agreement / Purchase Order is found to be defective or does not conform to the intent of the Contract / Agreement / Purchase Order, the awarded vendor shall, after receipt of notice from the City of Fairhope, correct the deficiencies. Failure on the part of the awarded vendor to properly correct the deficiencies within the time period allowed will constitute the City of Fairhope's right to cancel the Contract / Agreement / Purchase Order immediately, upon written notice to the awarded vendor.

3. ADDENDA

All Addenda are part of the Contract Documents. Include resultant costs in the Bid. Addenda will be issued by email to all Bidders on record and posted to the City of Fairhope website www.FairhopeAL.gov. It is the responsibility of the bidder to verify that all addenda have been received, and to include all signed addenda in the bid submission

4. ADDITIONAL ORDERS

Unless it is specifically stated to the contrary in the bid response, the City of Fairhope reserves the option to place additional orders against a contract awarded as a result of this solicitation at the same terms and conditions; to extend the renewal date until a new bid is in place, if it is mutually agreeable.

5. APPLICABLE LAW

This Agreement is deemed to be under and shall be governed by and construed according to the laws of the State of Alabama. Any litigation arising out of the Agreement shall be heard in the Courts of Baldwin County, Alabama.

6. ASSIGNMENT

The awarded vendor shall not assign the Contract / Agreement / Purchase Order or sublet it as a whole without the express written permission of the City of Fairhope. The awarded vendor shall not assign any payment due them hereunder, without the express written permission of City of Fairhope. The City of Fairhope may assign the Contract / Agreement / Purchase Order, or sublet it as a whole, without the consent of the awarded vendor.

7. ASSURANCE OF NON-CONVICTION OF BRIBERY

The bidder hereby declares and affirms that, to its best knowledge, none of its officers, directors, or partners and none of its employees directly involved in obtaining contracts has been convicted of bribery, attempted bribery, or conspiracy to bribe under the laws of any state or Federal government.

8. AWARD CONSIDERATION

The following factors will be considered in determining the lowest **responsible** bidder: Overall quality, Conformity with specifications both general and specific, Purposes for which materials or services are required, Delivery dates and time required for delivery, Unit acquisition cost, financial ability to meet the contract, previous performance, facilities and equipment, availability of repair parts, experience, delivery promise, terms of payments, compatibility as required, other costs, and other objective and accountable factors which are reasonable.

9. AWARD OR REJECTION OF BIDS

The Bid will be awarded to the lowest responsible bidder complying with conditions of the invitation for bids, provided his bid is reasonable and it is in the interest of the City of Fairhope to accept it. The bidder to whom the award is made will be notified at the earliest possible date. The City of Fairhope, however, reserves the right to reject any and all bids and to waive any informality in bids received whenever such rejection or waiver is in the interest to the City of Fairhope.

10. BACK ORDERS

If it is necessary to back order any items, the vendor must notify the Purchasing Department and advise as to the expected shipping or delivery date. If this date is not acceptable, the City of Fairhope may seek remedies for default.

11. BID AND PERFORMANCE SECURITY

If bid security is required, a bid bond or cashier's check in the amount indicated on the bid cover must accompany the bid and be made payable to The City of Fairhope of Baldwin County, AL. Corporate or certified checks are not acceptable. Bonds must be in a form satisfactory to the City and underwritten by a company licensed to issue bonds in the State of Alabama. If bid security fails to accompany the bid, it shall be deemed unresponsive, unless the Purchasing Manager deems the failure to be non-substantial. All checks will be returned to the bidders after the contract has been approved. If a performance bond is required, the successful bidder will be notified after the awarding of the contract.

12. BRAND NAMES

Reference to brand names and numbers is descriptive, but not restrictive, unless otherwise specified. Bids on equivalent items meeting the standards of quality thereby indicated will be considered, providing the bid clearly describes the article offered and indicates how it differs from the referenced brands. Descriptive literature or manufacturers specifications plus any supplemental information necessary for comparison purposes should be submitted with the bid or the bid on that item may be rejected. Reference to literature submitted with a previous bid or on file with the Division of Purchasing will not satisfy this requirement. The burden is on the bidder to demonstrate that the item bid is equivalent to the item specified in the ITB. Bids without sufficient documentation to fully support equality, may be considered non-responsive. Reference by the City of Fairhope in the ITB to available existing specifications shall be sufficient to make the terms of such specifications binding on the bidder. Unless the bidder specifies otherwise in its bid, it is understood the bidder is offering a referenced brand item as specified in the ITB or is bidding as specified when no brand is referenced. Failure to examine drawings, specifications and instructions will be at the bidder's risk.

13. BUSINESS LICENSE

The vendor selected to enter into a Contract / Agreement with the City of Fairhope must be licensed to do business in the City of Fairhope prior to commencement of any work under the contract. Delivery of goods or services to the City of Fairhope by Purchase Order have detailed and varied Business License requirements. In all instances that require a business license. Awarded vendor will provide proof of possessing a current City of Fairhope Business License. Prospective bidders will not be required to possess a City of Fairhope Business License prior to award.

14. CANCELLATION OF / CONTRACT / AGREEMENT / PURCHASE ORDER / LEASE

A purchase order can be canceled in whole or in part when awarded vendor fails to deliver or perform as specified. Cancellation of a purchase order can only be made by a written purchase order change (POC) from the City of Fairhope. A term contract, lease or agreement can be canceled by the City of Fairhope, for justifiable cause, or convenience, by written notice.

15. CERTIFICATION PURSUANT TO ACT NO. 2006-557

Alabama law (section 41-4-116, code of Alabama 1975) provides that every bid submitted and contract executed shall contain a certification that the vendor, contractor, and all of its affiliates that make sales for delivery into Alabama or leases for use in Alabama are registered, collecting, and remitting Alabama state and local sales, use, and/or lease tax on all taxable sales and leases into Alabama. By submitting this bid, the bidder is hereby certifying that they are in full compliance with act no. 2006-557, they are not barred from bidding or entering into a contract pursuant to 41-4-116, and acknowledges that the awarding authority may declare the contract void if the certification is false. All corporations must register to do business in Alabama with the Office of the Secretary of State. Their address is:

Office of the Secretary of State

P.O. Box 5616

Montgomery, AL 36103

(334) 242-5324

Fax: (334) 240-3138

<http://www.sos.state.al.us/index.aspx>

The Foreign Corporation form is online at <http://www.sos.state.al.us/downloads/dl1.cfm>.

16. COST OF REMEDYING DEFECTS

All defects, indirect and consequential costs of correcting, removing, or replacing any or all of the defective materials or equipment will be charged against the awarded vendor.

17. DELIVERY OF BID

Bids must be received in the Purchasing Office by the date and time specified on the bid cover. All bids will be accepted until the time and date stated on the bid cover. No bids will be accepted that extend past the time and date on the bid cover. The time of receipt shall be determined by the time clock stamp in the Purchasing Department. Bids submitted by U.S. Mail must be received by the City of Fairhope of Baldwin County, Alabama, in the City of Fairhope offices, 555 South Section St., Fairhope, Al., unless otherwise specified.

18. DELIVERY

The number of calendar days required for delivery after receipt of a purchase order shall be stated in the RFQ / ITB / RFP and /or Purchase Orders. When no time is stated in the document, the time shall be fourteen (14) calendar days after receipt of order. If a shipment is not made within the time period specified, the Purchase Order may be canceled.

19. ENVIRONMENTAL REQUIREMENTS

All products will be clearly labeled for their intended use. Each delivery of product or materials will include a Material Safety Data Sheet (MSDS) for all materials that require an MSDS. All manufacturers/distributors of hazardous substances, including any of the items listed on this bid/quote/ contract and subsequent award must include completed material safety data sheet (MSDS) for each hazardous material. Additionally, each container of hazardous materials must be appropriately labeled with:

- a) The identity of the hazardous material,
- b) Appropriate hazard warnings, and manufacturer, importer, or other responsible party.

20. EQUIPMENT DEMONSTRATION

The City of Fairhope may require equipment/ product materials or service techniques to be demonstrated at a time, date, and location to be specified by the City of Fairhope.

21. EQUIPMENT ELECTRICAL CERTIFICATION

All electrical equipment purchased shall conform to, and be identified in, the applicable standard(s), or otherwise be certified as applicable, as of the bid opening date and time, by Underwriters Laboratories, Inc., or other recognized laboratory facility. Bidder must provide satisfactory documentation with returned bid that all such equipment meets the applicable product standard or has otherwise been certified as outlined above. Unless indicated in the bid document, the above certification shall apply to the equipment itself, not the individual components of that equipment.

22. ERRORS IN BID

Bidders are assumed to be informed regarding conditions, requirements, and specifications prior to submitting bids. Failure to do so will be at the bidder's risk. Bids already submitted may be withdrawn without penalty prior to bid opening. Errors discovered after the bid opening may not be corrected.

23. FORCE MAJEURE

Neither the City nor the awarded vendor shall be deemed in breach of any contract / Purchase Order or Agreement which may result from this proposal submission if it is prevented from performing any of the obligations hereunder by reason of Acts of God, acts of the public enemy, acts of superior governmental authority, strikes or labor disputes, floods, riots, rebellion, sabotage, or any similar other unforeseeable causes beyond its control and not due to its fault or negligence. Each party shall notify the other immediately in writing of the cause of such after the beginning period thereof. The awarded vendor may request cancellation and the City of Fairhope may grant the request if performance is prevented by any of the above referenced causes, or other unavoidable circumstances not attributable to the fault or negligence of the vendor. The burden of proof for such relief rests with the vendor. All correspondence pertaining to cancellation of a purchase order or term contract must be addressed to the City of Fairhope Purchasing Manager.

24. HAZARDOUS AND TOXIC SUBSTANCES

Bidder must comply with all applicable Federal, State, County and City laws, ordinances and regulations relating to hazardous and toxic substances, including such laws, ordinances and regulations pertaining to information hazardous and toxic substances, and as amended from time to time. Bidder shall provide the City of Fairhope with a "Material Safety Data Sheet" for all goods that carry one.

25. INDEMNITY

Indemnity: The awarded vendor hereby agrees to indemnify and save harmless the City of Fairhope, its officers, agent, and employees, from and against any and all liabilities, claims, demands, damages, fines, fees, expenses, penalties, suits, proceedings, actions and cost of actions, including reasonable attorney fees for trial and on appeal, of any kind and nature, arising or growing out of, or in any way connected with the performance of this Contract / Agreement / Purchase Order, to the extent caused by a negligent act or omission of the awarded vendor, their agents, servants, employees, Subcontractors, or others associated with the awarded vendor. The awarded vendor shall be responsible for damage to any equipment excluded from this agreement, or damage or injury caused by any equipment excluded from this agreement, only to the extent that the damage or injury is caused by a negligent act or omission of the awarded vendor or caused by failure of the awarded vendor's supplied product to perform as specified.

26. INSPECTION

All materials, workmanship, equipment, and supplies are subject to inspection and test at any source or time. Final inspection, acceptance or rejection will be made at delivery destination. Goods that do not meet specifications will be rejected unless substitutions have been approved by the City of Fairhope. Failure to inspect or to reject upon receipt, however, does not relieve the awarded vendor of liability. When subsequent tests, after receipt, are conducted and when such tests reveal a failure to meet specifications, the City of Fairhope will reject the goods and the awarded vendor shall immediately supply goods meeting specifications or the City of Fairhope may seek damages including but not limited to the testing expense, regardless of whether a part of or all of the goods have been consumed through the testing process. Rejected goods shall be removed by the awarded vendor promptly after rejection, at his expense. If not removed in fourteen (14) calendar days, they may be disposed of at the discretion of the City of Fairhope. Disposal costs will be the awarded vendor's responsibility.

27. INSPECTION OF PREMISES

At reasonable times, the City may inspect those areas of the awarded vendor's place of business that are related to the performance of a Contract / Agreement / Purchase Order. If the City makes such an inspection, the awarded vendor must provide reasonable assistance. The City of Fairhope reserves the right on demand and without notice all the vendor's files associated with a subsequent Contract / Agreement / Purchase Order where payments are based on the awarded vendor's record of time, salaries, materials, or actual expenses. This same clause will apply to any subcontractors assigned to the Contract / Agreement / Purchase Order.

28. INSURANCE

If a Contract / Agreement / Purchase Order results from this RFQ / ITB / RFP, or other form of solicitation, the awarded vendor shall maintain such insurance as will indemnify and hold harmless the City of Fairhope from Workmen's Compensation and Public Liability claims from property damage and personal injury, including death, which may arise from the awarded vendor's operations under this Contract / Agreement / Purchase Order, or by anyone directly or indirectly employed by him/her.

29. INVITATION TO BID

Any provisions made in the RFQ / ITB / RFP, or other form of solicitation, supersedes any provisions outlined here in the General Terms and Conditions.

30. INVOICING, DELIVERY, PACKAGING

Invoices shall be prepared only after ordered materials have been delivered. All invoices must show the purchase order number. Unless otherwise specified in writing, vendors shall not ship any material without an authorized Purchase Order from the City of Fairhope Purchasing Department. All packages delivered must show the purchase order number. The awarded vendor will be required to furnish all materials, equipment and/or service called for at the bid price quoted. In the event the awarded vendor fails to deliver within a reasonable period of time, as determined by the City of Fairhope, the right is reserved to cancel the award and subsequent purchase order and purchase from the next lowest responsible bidder the items needed. The original awarded vendor will be back charged the difference between the original contract price and the price the City of Fairhope has to pay as a result of the failure to perform by the original awarded vendor. All bids will remain firm for acceptance for 60 days from the date of bid opening. Prices shall be net F.O.B., Prepaid and Allow, City of Fairhope chosen site, Baldwin County, AL. The title and risk of loss of the goods will not pass to the City of Fairhope until receipt and acceptance takes place at the F.O.B. point.

31. LABELING

Individual shipping cartons shall be labeled with the name "City of Fairhope", Purchase Order Number, and where applicable, Contract Number, date of manufacture, batch number, storage requirements, conditions, and recommended shelf life. Bidders are encouraged to offer product packaging with recycled content.

32. LOSS OR DAMAGE IN TRANSIT

Delivery by a vendor to a common carrier does not constitute delivery to the City of Fairhope. Any claim for loss or damage incurred during delivery shall be between the vendor and the carrier. The City of Fairhope accepts title only after satisfactory receipt at the delivery point. The City of Fairhope shall note all visible damages on the freight bill and may refuse the damaged goods. The vendor shall make immediate replacement of the damaged merchandise or be subject to damages for breach of contract. If damage is to a small portion of a total shipment and the City of Fairhope will not be inconvenienced because of the shortage, the vendor may be permitted by the Purchasing Manager to deduct the amount of damage or loss from its invoice, in lieu of replacement. Risk of loss during delivery is borne by the vendor until the goods have been accepted by the City of Fairhope, unless otherwise specified in the RFQ / ITB / RFP or other form of solicitation.

33. MANDATORY SITE VISIT

If the RFQ / ITB / RFP or other form of solicitation requires a mandatory site visit, bidders must inspect the site where installation or service is to take place to obtain a full understanding of scope of work outlined therein. Date of site visit will be determined by the City of Fairhope.

34. MONITORING OF SERVICES

Performance of services will be monitored by the requisitioning department and/or the Purchasing Department, and evaluation reports may be filed with the Purchasing Department. Performance not meeting specifications will result in cancellation of Contract / Agreement / Purchase Order and may result in vendor being removed from the vendor list.

35. NONCONFORMING MERCHANDISE

When merchandise received from the lowest responsible bidder is not in accordance with the purchase order, it will be returned to the bidder, at bidder's expense.

36. NON-DISCRIMINATION

The City of Fairhope is an Equal Opportunity Employer and requires that all contractors comply with the Equal Employment Opportunity laws and the provisions of the Contract / Agreement / Purchase Order documents in this regard. The City also encourages and supports the utilization of Minority Business Enterprises on this and all public bids.

37. NON-EXCLUSIVE

Unless otherwise specified, this Contract / Agreement / Purchase Order is considered a non-exclusive Contract / Agreement / Purchase Order between the parties.

38. NOTIFICATION AND ACCIDENT REPORTS

In the event of accidents of any kind, in the performance of a Contract / Agreement / Purchase Order, the awarded vendor shall notify the City of Fairhope immediately and furnish, without delay, copies of all such accident reports to the City of Fairhope. If in the performance of their Work, the awarded vendor fails to immediately report an accident to the City of Fairhope, of which the awarded vendor has knowledge of and which results in a fine levied against the City of Fairhope then the awarded vendor shall be responsible for all fines levied against the City of Fairhope.

39. PACKAGING

All goods must be packaged in new packing containers. Packing that meets the requirements of common carriers is acceptable, unless otherwise required. A packing slip or invoice must accompany all shipments and must reference the purchase order number. Unless otherwise specified, goods are to be packaged in cartons meeting federal specifications and shipped on non-returnable pallets.

40. PATENTS

Awarded Vendor guarantees that the sale and / or use of goods will not infringe upon any U.S. or foreign patent. Awarded vendor will at his / her own expense, indemnify, protect and save harmless the City of Fairhope, on any patent claims arising from the purchase of goods or services.

41. PAYMENT

Invoices -- Upon completion of service and delivery of materials specified in the applicable Contract / Agreement / Purchase Order, awarded vendor will submit an invoice and signed delivery ticket to:

City of Fairhope
Accounts Payable Department
P.O. Box 429
Fairhope, Al. 36533

All invoices must reference appropriate Purchase Order Numbers Payment of Invoice: All invoices received by the City of Fairhope are payable within thirty (30) days from the date of receipt by the City of Fairhope, provided they are approved by the City of Fairhope.

42. PAYMENT WITHHELD

Payment may be withheld until all items have been delivered and all requirements of the Contract / Agreement / Purchase Order have been fulfilled

43. PRODUCT TESTING

Vendor shall incur all cost involved in obtaining an Independent Laboratory Test if the City deems necessary during the term of the Contract / Agreement / Purchase Order. The City of Fairhope reserves the right to request a demonstration of any and all items bid before making the award.

44. PERMITS LICENSES AND CERTIFICATES

The awarded vendor is to procure all permits, licenses, and certificates, or any approvals of plans or specifications as may be required by Federal, State, Local Laws, ordinances, rules, and regulations, for the proper execution and completion of Work covered under the Contract / Agreement / Purchase Order.

45. PREPARATION OF BID

All bids / proposals shall be typewritten or in ink on the form(s) prepared by the City of Fairhope. Bids / proposals prepared in pencil will not be accepted. All bids / proposals must be signed by officials of the corporation or company duly authorized to sign bids / proposals. Any bid / proposal submitted without being signed will automatically be rejected. All corrections or erasures shall be initialed and dated by the person authorized to sign quotations /bids / proposals. If there are discrepancies between unit prices quoted and extensions, the unit price will prevail.

46. QUESTIONS / CONTACT

Commencing with the issuance of the RFQ / ITB / RFP, or other form of solicitation, no vendor or anyone acting on a vendor's behalf, shall make direct or indirect contact with City personnel or undertake any activities or take any action to otherwise promote its quotation / bid / proposal to the City or its personnel. All communications shall be made to the contact identified in the quotation / bid / proposal documents. Violation of this requirement may, at the City's sole and absolute discretion, be grounds for disqualifying a vendor from further consideration.

47. RECEIPT BY CITY OF FAIRHOPE

If not otherwise stated in the order, the City of Fairhope will be said to have received goods when they have been delivered, unloaded, and placed on the agency's dock or if there is no dock, inside an accessible building, and signed for by an authorized City employee. Shipments will be checked against the receiving copy of the Purchase Order. If the purchase order requires grading certificates, USDA Stamps, or any proof of quality, such proof must accompany the shipment.

48. REJECTION OF BIDS

The City of Fairhope reserves the right to accept or reject any or all bids in whole or in part for any reason, to waive technicalities or informalities, or to advertise for new proposals, if, in the judgment of the awarding authority, the best interest of the City of Fairhope will be promoted thereby. Bidders may be disqualified and rejection of proposals may be recommended for any of (but not limited to) the following causes: Failure to use the bid forms furnished by the City of Fairhope, Lack of signature by an authorized representative on the bid form, Failure to properly complete the bid form and vendor compliance, Evidence of collusion among bidders, Unauthorized alteration of the bid form.

49. RIGHT TO AUDIT

The awarded vendor shall maintain documentation of all work performed. The awarded vendor shall make any and all documentation available to the City of Fairhope at all reasonable times, for inspections and audit by the City of Fairhope for a period of Three (3) years after expiration of the Contract / Agreement / Purchase Order.

50. SAMPLES

Bidders will not be required to furnish samples at the time of bid opening, unless specifically called for. The City of Fairhope reserves the right to request samples after bid opening to assist in the evaluation of proposals submitted.

51. SAFETY MEASURES

The awarded vendor shall take all necessary precautions for the safety of the City of Fairhope's and awarded vendor's employees at the Work site, and shall erect and properly maintain at all times, all necessary safeguards for the protection of the workmen and the public. The awarded vendor shall post signs warning against hazards in and around the Work site.

52. SET-UP AND INSTALLATION

Unless otherwise specified, bid / quotation to include cost of all uncrating, disposal of shipping materials, set-up, testing and initial instruction to agency personnel.

53. SPILL CLEAN UP

The awarded vendor shall be responsible for spillage caused by their negligence, which occurs during transit or unloading operations. The awarded vendor shall immediately report and clean up any spillage. Upon failure to do so, the awarded vendor shall remain responsible for all actual related costs.

54. SUBSTITUTIONS

Substitutions on a purchase order shall require the approval of the Originating Buyer. The City of Fairhope reserves the right to reject at destination and hold at the vendor's risk and expense any goods supplied by the vendor which do not conform to the specification or description embodied in the order or are inferior in any respect to the good specified. Any good bought by sample which is inferior in quality to the sample submitted by vendor will be rejected. Any goods delivered that do not meet specifications may be returned to the vendor at its expense. When a good is returned, the vendor must make immediate replacement with acceptable merchandise, or the City of Fairhope may seek remedies for default.

55. TABULATION

Bid results are posted on The City of Fairhope's web site: www.FairhopeAL.gov. The awarded vendor will be sent a written notification.

56. TAXES

Prices quoted shall be delivered prices, exclusive of all federal or state excise, sales, and manufacturer's taxes. The City will assume no transportation or handling charges other than specified in the RFQ, ITB, RFP or other form of solicitation. The City is tax exempt by law – Code of Alabama 1975.

57. TERMINATION FOR CONVENIENCE

Any Contract / Agreement / Purchase Order may be terminated for convenience by the City of Fairhope, in whole or in part, by written notification to the awarded vendor.

58. TERMINATION FOR DEFAULT

Performance of Work under the Contract / Agreement / Purchase Order Agreement may be terminated by the City of Fairhope, in whole or in part, in writing, whenever the City of Fairhope determines that the awarded vendor has failed to meet the requirements of the Contract / Agreement / Purchase Order.

59. TERMINATION FOR NON-APPROPRIATION

Termination for Non-appropriation – The continuation of any financial obligation beyond the current fiscal year is subject to and contingent upon sufficient funds being appropriated, budgeted, and otherwise made available by the local source, State Legislature and/or federal sources. The City of Fairhope may terminate any financial obligation, and awarded vendor waives any and all claim(s) for damages, effective immediately upon receipt of written notice (or any date specified therein) if for any reason the City of Fairhope's funding from local, State and/or federal sources is not appropriated, withdrawn or limited.

60. TIME IS OF THE ESSENCE

The City of Fairhope and awarded vendor agree that time is of the essence in the performance of work called for under this Contract / Agreement / Purchase Order. The awarded vendor agrees that all work will be accomplished regularly, diligently, and uninterrupted at such a rate of progress as will ensure full completion thereof within reasonable time periods.

61. TITLE

All titles, fees, as well as other charges, are to be paid by awarded vendor. Awarded vendor is to furnish prepaid certificate of title in the name of the City of Fairhope, Title shall change upon acceptance of delivery at the City of Fairhope approved delivery location.

62. VENDOR LIST

A vendor may be removed from the City of Fairhope's Bidders List if a vendor fails to respond to three (3) consecutive ITB's. A properly submitted "No Bid" is considered as a response and the vendor will receive credit for the response.

63. WARRANTY

The awarded vendor expressly warrants that all articles, materials, and work offered shall conform to each and every specification, drawing, sample, or other description which is furnished to or adopted by the City of Fairhope, and that it will be fit and sufficient for the purpose intended, merchantable, of good material and workmanship, and free from defects. The awarded vendor further warrants all items for a period of one year, unless otherwise stated, from the date of acceptance of the items delivered and installed or work completed. All repairs, replacements, or adjustments during the warranty period will be at the awarded vendor's sole expense. Awarded vendor will provide written warranty for all parts and labor for a period of (1) one year commencing from date of written acceptance of delivery by City of Fairhope. Awarded vendor will provide written copies of all other applicable warranties, such as, Manufacturer's warranty. Those warranties, if any, will be in addition to the awarded vendor's warranty, and the terms of which will not be altered by the awarded vendor's warranty.

64. IMMIGRATION LAW

The Contractor agrees that it shall comply with all of the requirements of the **Beason-Hammon Alabama Taxpayer and Citizen Protection Act, Act No 2011-535**, Alabama Code (1975) Section 31-13-1, et. Seq., (also known as the Alabama Immigration Act) see Section 31-13-9, and the provisions of said Act, including all penalties for violation thereof, are incorporated herein.

ITEM VIII

ALABAMA IMMIGRATION ACT CONTRACT REQUIREMENTS

1.0 Background

The **Beason-Hammon Alabama Taxpayer and Citizen Protection Act, Act No 2011-535, as amended by Act No 2012-491, Code of Alabama (1975) Section 31-13-1 through Section 31-13-30** (also known as and hereinafter referred to as “the Alabama Immigration Act”) is applicable to CONTRACTs with the City of Fairhope, Alabama. All business entities entering into CONTRACTs with the City of Fairhope, Alabama will comply with the Alabama Immigration Act.

2.0 Definitions

ALIEN. Any person who is not a citizen or national of the United States, as described in 8 U.S.C. § 1101, et seq., and any amendments thereto.

BUSINESS ENTITY. Any person or group of persons employing one or more persons performing or engaging in any activity, enterprise, profession, or occupation for gain, benefit, advantage, or livelihood, whether for profit or not for profit. Business entity shall include but not be limited to the following:

- a. Self-employed individuals, business entities filling articles of incorporation, partnerships, limited partnerships, limited liability companies, foreign corporations, foreign limited partnerships, foreign liability companies authorized to transact business in this state, business trusts, and any business entity that registers with the Secretary of State.
- b. Any business entity that possesses a business license, permit, certificate, approval, registration, charter, or similar form of authorization issued by the state, any business entity that is exempt by law from obtaining such a business license, an any business entity that is operating unlawfully without a business license.

CONTRACTOR. A person, employer, or business entity that enters into a CONTRACT to perform any service or work or to provide a certain product in exchange for valuable consideration. This definition shall include, but not be limited to, a general CONTRACTOR, SUB-CONTRACTOR, independent CONTRACTOR, CONTRACT employee, project manager, or a recruiting or staffing entity.

EMPLOYEE. Any person directed, allowed, or permitted to perform labor or service of any kind by an employer. The employees of an independent CONTRACTOR working for a business entity shall not be regarded as the employees of the business entity, for the purposes of this chapter. This term does not include any inmate in the legal custody of the state, a county, or a municipality.

EMPLOYER. Any person, firm, corporation, partnership, joint stock association, agent, manager, representative, foreman, or other person having control or custody of any employment, place of employment, or of any employee, including any person or entity employing any person for hire within the State of Alabama, including a public employer. This term shall not include the occupant of a household contracting with another person to perform casual domestic labor within the household.

E-VERIFY. The electronic verification of federal employment authorization program of the Illegal Immigration Reform and Immigrant Responsibility Act of 1996, P.L. 104-208, Division c, Section 403 (a); 8 U.S.C. §1324(a) and operated by the United States Department of Homeland Security, or its successor program.

STATE-FUNDED ENTITY. Any governmental entity of the state or a political subdivision thereof or any other entity that receives any monies from the state or a political subdivision thereof; provided, however, an entity that merely provides a service or a product to any governmental entity of the state or a political subdivision thereof, and receives compensation for the same, shall not be considered a state-funded entity.

SUB-CONTRACTOR. A person, business entity, or employer who is awarded a portion of an existing CONTRACT by a CONTRACTOR, regardless of its tier.

UNAUTHORIZED ALIEN. An alien who is not authorized to work in the United States as defined in 8 U.S.C. § 1324a (h) (3) .

3.0 Mandatory Clause

All CONTRACTS or CONTRACTS to which the state, a political subdivision, or state-funded entity are a party shall include the following clause:

"By signing this CONTRACT, the CONTRACTING parties affirm, for the duration of the CONTRACT, that they will not violate federal immigration law or knowingly employ, hire for employment, or continue to employ an unauthorized alien within the state of Alabama. Furthermore, a CONTRACTING party found to be in violation of this provision shall be deemed in breach of the CONTRACT and shall be responsible for all damages resulting therefrom."

For purposes of this section, "CONTRACT" shall mean a CONTRACT awarded by the state, any political subdivision thereof, or any state-funded entity that was competitively bid or would, if entered into by the state or an agency thereof, be required to be submitted to the CONTRACT Review Permanent Legislative Oversight Committee.

4.0 CONTRACTS Involving Business Entity, or Employer

As a condition for the award of any CONTRACT, grant, or incentive by the state, any political subdivision thereof, or any state-funded entity to a business entity or employer that employs one or more employees, the business entity or employer shall not knowingly employ, hire for employment, or continue to employ an unauthorized alien within the State of Alabama.

As a condition for the award of any CONTRACT, grant, or incentive by the state, any political subdivision thereof, or any state-funded entity to a business entity or employer that employs one or more employees within the state of Alabama, **the business entity or employer shall provide documentation establishing that the business entity or employer is enrolled in the E-Verify program.** During the performance of the CONTRACT, the business entity or employer shall participate in the E-Verify program and shall verify every employee that is required to be verified according to the applicable federal rules and regulations.

5.0 CONTRACTS Involving Subcontracting

Any SUB-CONTRACTOR on a project paid for by CONTRACT, grant, or incentive by the state, any political subdivision thereof, or any state-funded entity shall not knowingly employ, hire for employment, or continue to employ an unauthorized alien within the State of Alabama and shall also enroll in the E-Verify program prior to performing any work on the project. Furthermore, during the performance of the CONTRACT, the SUB-CONTRACTOR shall participate in the E-Verify program and shall verify every employee that is required to be verified according to the applicable federal rules and regulations. This subsection shall only apply to SUB-BIDDERS performing work on a project subject to the provisions of this section and not to collateral persons or business entities hired by the SUB -CONTRACTOR.

6.0 Proof of E-Verify documentation will be in the form of a copy of the signed Memorandum Of Understanding (MOU) generated upon completion of the E-Verify program.

END OF ALABAMA IMMIGRATION ACT CONTRACT REQUIREMENTS

ITEM IX

INVITATION SUMMARY

**Bid No. 24-060-2024-PWI-002
New Tennis & Pickleball Courts at Mike Ford Tennis Center
Public Works Project No. 2024-PWI 002**

Bid Name:	BID 24-060-2024-PWI-002 New Tennis & Pickleball Courts at Mike Ford Tennis Center
Issue Date:	July 19, 2024
Certificate of Insurance Requirements:	See Item V
MANDATORY Pre-Bid Meeting:	Thursday, August 8, 2024, 2:00 P.M.
Deadline for Questions Date:	Friday, August 9, 2024, 11:00 A.M.
Bid Due Date:	Tuesday, August 13, 2024, 2:00 P.M.
City Internet Site:	www.FairhopeAL.gov
SEALED Bid Response Copies to submit:	One (1) Original Paper Copy
Purchasing Department Contact for questions:	Purchasing@FairhopeAL.gov (251) 928-8003

END OF INVITATION SUMMARY

**ITEM X
BID BOND INFORMATION**

Bids shall be accompanied by a Bid Security equal to 5% (percent) of the bid price, but in no event more than \$10,000.00. Bid Security shall be in the form of a Bid Bond or a cashier's check payable to The City of Fairhope. All bonds and/or cashier's check will be made payable to the City of Fairhope for an amount not less than five (5) percent of the City's or its engineers or architects estimated cost of the Project or of the total bid in the proposal, but in no event more than \$10,000.00.

Return of Bid Bonds: All bid bonds, except those of the three lowest bona fide bidders, will be returned immediately after bids have been checked, tabulated and the relation of the bids established. The bid bonds of the three lowest bidders may be retained and if so, will be returned as soon as the contract bonds and the contract documents of the successful bidder have been approved and properly executed.

In the event it is necessary to defer a contract award for longer than fifteen (15) days, after opening of bids, then all bid bonds, except that of the potential successful bidders will be returned.

Award of the contract will be made within the time specified after the opening of bids. In the event no award is made within such time, all bids may be rejected, and all bonds returned.

Provided; however, the potentially successful bidder may enter into a written agreement with the City for an extension of time for consideration of its bid, in which case, the bidder's bond shall remain in full force and effect, or the City may permit said bidder to substitute a satisfactory surety for the cashier's check if submitted as a guaranty to the bid bond.

Forfeiture of Bid Bonds: Should the successful bidder or bidders to whom a contract is awarded fail to execute a contract(s) and furnish acceptable contract securities and evidence of insurance, as required, within thirty (30) days after the prescribed forms have been presented to him/her, the City may retain from the proposal guaranty, if it is a cashier's check or recovered from the principal or the sureties, if the guaranty is a bid bond, the difference between the amount of the contract as awarded, and the amount of the proposals of the new lowest bidder. If no other bids are received, the full amount of the proposal guaranty may be so retained and recovered as liquidated damages for such default. Any sum so retained or recovered shall be the property of the awarding authority.

END OF BID BOND INFORMATION

ITEM X
BID BOND

The PRINCIPAL (Bidder's name and address)

The OWNER
City of Fairhope
P.O. Drawer 429
Fairhope, Al 36533

The PROJECT for which the Principal's Bid is submitted: (Project name as it appears in the Bid Documents)

PROJECT NO.
PROJECT NAME:

KNOW ALL MEN BY THESE PRESENTS, that we, the undersigned Principal and Surety, jointly and severally, hereby bind ourselves, our heirs, executors, administrators, successors, and assigns to the OWNER in the PENAL SUM of five percent (5%) of the amount of the Principal's bid, but in no event more than TEN THOUSAND DOLLARS (\$10,000.00).

THE CONDITION OF THIS OBLIGATION is that the Principal has submitted to the OWNER the attached bid, which is incorporated herein by reference, for the Project identified above.

NOW, THEREFORE, if, within the terms of the Bid Document, the OWNER accepts the Principal's bid and the Principal thereafter either:

- (a) executes and delivers a Construction Contract with the required Performance and Payment Bonds (each in the for contained in the Bid Documents and properly completed in accordance with the bid) and delivers evidence of insurance as prescribed in the Bid Documents, or fails to execute and deliver such Construction Contract with such Bonds and evidence of insurance, but pays the OWNER the difference, not to exceed the Penal Sum of this Bond, between the amount of the Principal's Bid and the larger amount for which the OWNER may award a Construction Contract for the same Work to another Bidder, then, this obligation shall be null and void, otherwise it shall remain in full force and effect.

The Surety, for value received, hereby stipulates and agrees that the obligation of the Surety under this Bond shall not in any manner be impaired or affected by any extension of the time within which the OWNER may accept the Principal's bid, and the Surety does hereby waive notice of any such extension.

SIGNED AND SEALED this _____ day of _____, 202_____.

(Principal (Company))
By _____

Print Name and Title

SURETY
ATTEST

By _____
Surety Company

Print Name and Title

CORPORATION

Name of Corporation, Partnership, or Joint Venture

Business Mailing Address: _____

email _____ phone _____

BY: _____
(Signature of Officer Authorized to sign Bids
and Contracts for the Firm)

(Position or Title)

(General Contractor's License Number)
vendors)

Foreign Corporation Entity Id (Required of out-of-state-

Attest:

(Secretary)

(Name of State under the laws of which incorporated)

(Name of Surety)

BY: _____
(Attorney in Fact)

**ITEM XI
PERFORMANCE BOND**

KNOW ALL MEN: That _____ as Principal,
(name & address of legal title of contractor)

and _____ and
(name & address of legal title of one or more sureties)

(name & address of legal title of one or more sureties)

Hereinafter called the Surety or Sureties, are held and firmly bound unto the CITY OF FAIRHOPE, ALABAMA, hereinafter called the OWNER in the sum of _____ Dollars (\$ _____), for the payment whereof the Principal and the Surety or Sureties bind themselves, their heirs, executors, administrators, successors, and assigns, jointly and severally, firmly by these presents.

WHEREAS, The Principal has, by means of a written agreement, dated ____ / ____ / ____, entered into a contract with the OWNER for **Bid No. 24-060-2024-PWI-002 New Tennis & Pickleball Courts at Mike Ford Tennis Center**, which agreement is by reference made a part hereof.

NOW THEREFORE, the conditions of this obligation is such that if the Principal shall faithfully perform the contract on his part, and satisfy all claims and demands, incurred for the same, and shall fully indemnify and save harmless the OWNER from all cost and damage which he may suffer by reason of failure to do so, and shall reimburse and repay OWNER all outlay and expense which the OWNER may incur in making good for any such default thence this obligation shall be null and void: otherwise, it shall remain in full force and effect.

PROVIDED, HOWEVER, that no suit, action or proceedings, by reason of any default whatever be brought on his Bond after twelve months from the day on which the final payment under the Contract falls due.

PROVIDED, further, that the said surety or sureties, for value received hereby stipulate and agree that no change, extension of time, or addition to the terms of the Contract or to the work to be performed thereunder of the specifications thereof shall in any way effect their obligations on this bond, and they do hereby waive notice of any such change, extension of time, alteration or addition to the terms of the contract, or to the work, or to the Specifications.

WITNESS our hands this _____ day of _____, 202____.

IF INDIVIDUAL

_____, Doing Business As, _____
(SIGNATURE of Individual Bidder) (Business Name)

Business Mailing Address _____

IF CORPORATION

(Name of Corporation, Partnership, or Joint Venture)

Business Mailing Address _____

By: _____
(SIGNATURE of officer authorized to sign Bids and Contracts for the company) (Position or Title)

ATTEST:

(Secretary) (Name of State of incorporation)

(Name of Surety) By: _____
(Attorney in Fact)

**ITEM XII
LABOR AND MATERIAL BOND**

KNOWN ALL MEN BY THESE PRESENTS, that we, _____ (hereinafter called the "Contractor") of _____ as principal and _____ (hereinafter called the "Surety"), as Surety, do hereby acknowledge ourselves indebted and firmly bound and held unto the City of Fairhope, Alabama, (hereinafter called the "**City**"), a municipal corporation, existing under and by virtue of the Laws of the State of Alabama, for the use and benefit of those entitled thereto, in the penal sum of _____ (\$_____) for the payment of which well and truly to be made in lawful money of the United States, we do hereby bind ourselves, or successors, assigns and personal representatives, jointly and severally, firmly by these presents.

BUT THE CONDITION OF THE FOREGOING OBLIGATION OR BOND IS THIS:

WHEREAS, the **City** has entered into a certain written contract with said Contractor for **Bid No. 24-060-2024-PWI-002 New Tennis & Pickleball Courts at Mike Ford Tennis Center**, in accordance with contract documents heretofore on file in the Office of the **City of Fairhope** at the price of, to-wit: _____ (\$_____) as more fully appears in said written Contract bearing date of _____, 20____, which Contract is hereby referred to and made a part hereof to the same extent as if set out herein in full.

NOW, THEREFORE, if said Principal and all subcontractors to whom any portion of the work provided for in said contract is sublet and all assignees of said Principal and of such subcontractors shall promptly make payment to all persons supplying him or them with labor, foodstuffs, or supplies for or in the prosecution of the work provided for in such contract, or in any amendment or extension of or addition to said contract, and for the payment of reasonable attorney's fees, incurred by the claimant or claimants in suits on said bond, then the above obligation shall be void; otherwise, it shall remain in full force and effect.

PROVIDED, however, that this bond is subject to the following conditions and limitations:

(a) Any person, firm or corporation that has furnished labor, foodstuffs, or supplies for or in the prosecution of the work provided for in said contract, payment for which has not been made, shall have a direct right of action in his or their name or names against the principal and surety on this bond, which right of action shall be asserted in a proceeding, instituted in the county in which the work provided for in said contract is to be performed and in any county in which said Principal or Surety does business. Such right of action shall be asserted in a proceeding instituted in the name of the claimant or claimants for his or their use and benefit against said Principal and Surety or either of them (but not later than one year after the final settlement of said Contract) in which action such claim or claims shall be adjudicated and judgment rendered thereon.

(b) In addition to any other legal mode of service, service of summons and other process in suits on this bond brought in Baldwin County may be had on the Principal or the Surety in accordance with Title 27, Chapter 3, Section 24 of the Ala. Code (1975) by serving a copy of the summons and complaint or other pleading or process, with the Commissioner of Insurance of the State of Alabama or his/ her designee and the Principal and Surety agree to be bound by such mode of service above described and consents that such service shall be the same as personal service on the Principal or Surety.

(c) The Surety shall not be liable hereunder for any damages or compensation recoverable under any workmen's compensation or employer's liability statute.

(d) In no event shall the Surety be liable for a greater sum than the penalty of this bond, or subject to any suit, action or proceeding thereon that is instituted later than one year after the final settlement of said contract.

(e) This bond is given pursuant to the terms of Title 39, Chapter 1, Section 1 of the Ala. Code (1975), and all the provisions of law with reference to this character of bond as set forth in said section or as may hereinafter be enacted are hereby made a part hereof to the same extent as if set out herein in full.

IN WITNESS WHEREOF, the said Contractor has hereunder affixed its signature and said Surety has hereunto caused to be affixed its corporate signature and seal, by its duly authorized officers on the ____ day of _____, 20____.

Principal

By: _____

Title

Surety

ATTEST:

By: _____

Title

ITEM XIII



CITY OF FAIRHOPE CLOSEOUT DOCUMENTS

CONSENT OF SURETY COMPANY TO FINAL PAYMENT

CONTRACTOR'S AFFIDAVIT OF PAYMENT

FINAL RELEASE OF LIENS

NOTICE OF COMPLETION ADVERTISEMENT



**CITY OF FAIRHOPE
CONSENT OF SURETY COMPANY TO FINAL PAYMENT**

COF PROJECT NO: _____

COF PROJECT NAME: _____

OWNER: **City of Fairhope**
P.O. Drawer 429
Fairhope, AL 36533

CONTRACTOR: _____

In accordance with the provision of the Contract between the OWNER and the CONTRACTOR as indicated above, the _____, Surety Company on bond of _____ CONTRACTOR, hereby approved the final payment to the CONTRACTOR and agrees that final payment to the CONTRACTOR shall not relieve the Surety Company of any of its obligations to the City of Fairhope as set forth in said Surety Company's bond dated the _____ day of _____, 202____.

IN WITNESS WHEREOF

The Surety Company has hereunto set its hand this ____ day of _____, 202____.

ATTEST
(Seal)

Surety Company

Signature of Authorized Representative

Title



**CITY OF FAIRHOPE
CONTRACTOR'S AFFIDAVIT OF PAYMENT
OF CLAIMS & DEBTS**

COF PROJECT NO: _____

COF PROJECT NAME: _____

OWNER: **City of Fairhope**
P.O. Drawer 429
Fairhope, AL 36533

CONTRACTOR: _____

STATE OF: _____

COUNTY OF: _____

The undersigned hereby certified that, except as listed below, he has paid in full or otherwise satisfied all obligations for all materials and equipment furnished, for all work, Labor and services performed, and for all known indebtedness and claims against the CONTRACTOR for damages arising in any manner in connection with the performance of the Contract referenced above for which the OWNER or his property might in any way be held responsible.

EXCEPTION: (If none, write NONE) _____

CONTRACTOR

By: _____ Title: _____

Subscribed and sworn to and before me this ___ day of _____, 202__.

NOTARY PUBLIC

My Commission expires ___/___/___



**CITY OF FAIRHOPE
FINAL RELEASE OF LIENS**

KNOW ALL MEN BY THESE PRESENTS: In consideration of, and contingent upon the receipt of total payments in the amount of _____

Under and pursuant to the following contract:

COF PROJECT NO: _____

COF PROJECT NAME: _____

The undersigned hereby releases _____, its officers, agents, and employees, of and from all liabilities, obligations, and claims whatsoever in law and in equity under or arising out of said contract. We do hereby certify that all labor, materials, equipment, supplies, etc. for this project have been paid in full and there is no outstanding indebtedness.

IN WITNESS WHEREOF, this release has been executed this _____ day of _____, 202__.

CONTRACTOR

By: SIGNATURE

PRINTED NAME

Title

**STATE OF ALABAMA
COUNTY OF BALDWIN**

I, the undersigned authority, a Notary Public in and for said County and State, hereby certify that _____, whose name is signed to the foregoing instrument and who is known to me, acknowledged before me on this day that, being informed of the contents of the within instrument, he executed the same voluntarily on the day the same bears date.

Given under my hand and seal on this the _____ day of _____, 202__.

NOTARY PUBLIC

My Commission Expires: ___/___/___



**CITY OF FAIRHOPE
NOTICE OF COMPLETION LEGAL NOTICE**

Bid Number: _____

Bid Name: _____

In accordance with Chapter 1, Title 39, Code of Alabama, 1975, for contracts over \$50,000 and less than \$500,000, Notice is hereby given that

_____, CONTRACTOR, has completed the Contract for the above referenced bid for the City of Fairhope, Alabama, OWNER, and has made request for final settlement of said Contract. Any claims for labor, materials or otherwise in connection with this project should be itemized, notarized, and presented to:

OWNER:

**CITY OF FAIRHOPE
555 South Section Street
P.O. Drawer 429
Fairhope, AL 36533**

On or before (30 days) or same will be barred.

Contractor:

Dates ad was run (one time): _____

Newspapers in which ad run (dates): _____

Contractor to provide Proof of Publication of the Notice of Completion to the City by affidavit of the publisher and a printed copy of the notice published.

ACRYTECH™
SPORTS SURFACES

Acrylic Resurfacer

PREMIUM 100% ACRYLIC BASE COAT

AR- Acrylic Resurfacer
DESIGNED TO SMOOTH & LEVEL
PAVEMENT PRIOR TO COLOR COATING

Intended for new and existing asphalt or concrete based tennis courts, pickleball courts, basketball courts, running tracks, volleyball courts and other sports surfaces.

Colors: Black, Neutral

Advantages:

- High hide
- Heavy sand loading
- Easy squeegee pull



Self-Crosslinking
TECHNOLOGY

Also available as:
ACRYLIC RESURFACER WITH
FACTORY PREMIX SAND

TennisPaint.com • 888.294.0428



ACRYTECH™
SPORTS SURFACES

Colorguard™

CONCENTRATE & TEXTURED



We offer a high quality, user-friendly paint that looks great and lasts.

Installers prefer Colorguard™ for its superior workability, consistency and outstanding coverage. **Players love it** for its ideal ball speed, spin rate and rich color.

The art of
Acrylic Technology.™



**Self-Crosslinking
TECHNOLOGY**

- *Extremely Durable & Consistent*
- *Great for All Types of Climates*
- *UV & Slip Resistant*

- *Ask for factory textured line paint to ensure a consistent ball bounce.*
- *Systems are great for indoor or outdoor play.*
- *Quick-drying, all-weather surface for concrete or asphalt projects.*



TennisPaint.com • 888.294.0428

**MADE IN
USA**

ACRYTECH™
SPORTS SURFACES

Line Paint

AVAILABLE IN TEXTURED OR SMOOTH
COMES IN 1 GALLON JUGS &
5 GALLON PAILS



Self-Crosslinking
TECHNOLOGY

White Line Paint

Installer friendly, high hide, low bleed, 100% Acrylic.

Excellent for all acrylic sports surfaces.

Line Primer

For crisp, razor-sharp lines, use 100% acrylic, clear-drying primer. Apply prior to the line paint to reduce line bleed.

Colored Line Paint

Line marking colors Red, Orange, Yellow, Green, Blue and Black. Special colors available upon request.



*Textured Line Paint
ensures a uniform ball bounce.*

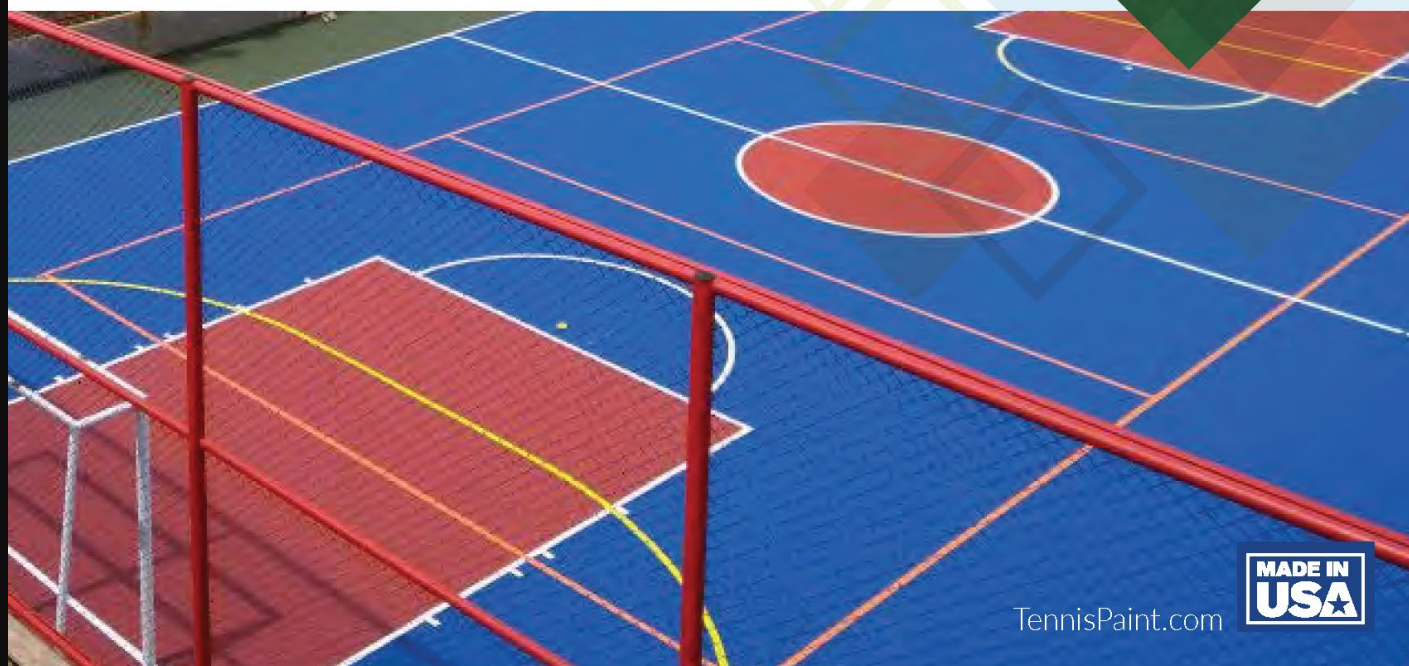

TennisPaint.com





PICKLEBALL

quality products

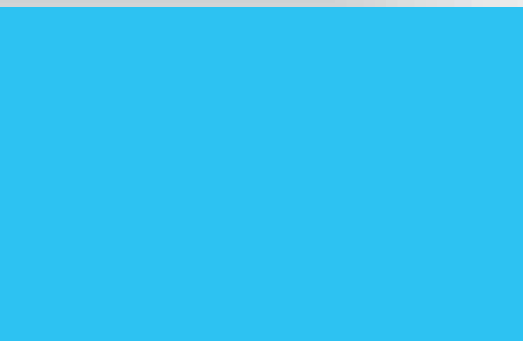
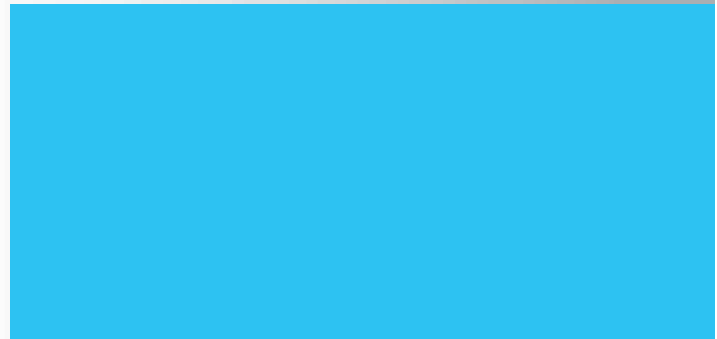

Douglas® Pickleball Posts & Nets

USA Manufactured
by Douglas® 



Pickleball Premier™ XS Posts

2 1/8"

Green (Item # 63074)
Black (Item # 63075)

The Cadillac of posts is also available for pickleball court construction measuring 54" in length to sit 36" above ground. These 2-7/8" OD round posts are constructed of 8-gauge steel. Posts are internally wound and feature a jam-free cable tensioning hardware system. Plated steel gear housings and caps are made of die-cast zinc. Gear function is 30:1 to ensure a smooth, easy operation. Posts feature Allied's® superior Flo-coat™ galvanization process and are then finished in forest green or black baked-on polyester powder coat to resist rust and increase durability. Integrated welded steel lacing rods are included for a professional net installation. Flush mounted gear plate cover and removable handle are chrome plated. Stainless Steel and Brass gears are also available.

Corresponding Ground Sleeves:

24" PVC (GS-24PVC) (Item # 63164)
24" Aluminum (GS-24RD) (Item # 63171)



Pickleball Premier™ RD Posts

3"

Green (Item # 63070)
Black (Item # 63071)

These popular posts are designed for pickleball court construction measuring 54" in length to sit 36" above ground. The Premier™ 3" OD round (RD) posts are constructed of heavy-duty 11-gauge steel. Posts are internally wound and feature a self-locking gear mechanism. Gears are constructed of plated steel and the small gear is case hardened. Gear housings and caps are made of cast aluminum alloy. Gear function is 30:1 to ensure a smooth, easy operation. Posts are finished in forest green or black baked-on polyester powder coat finish to resist rust and increase durability. Integrated welded steel lacing rods are included for a professional net installation. Gear plate cover and removable handle are chrome plated.

Corresponding Ground Sleeves:

24" Steel (GS-24) (Item # 63424)



SW-36 Deluxe Pickleball Posts

2 1/8"

Green (Item # 63078)
Black (Item # 63079)

These recreational workhorse posts are designed for pickleball court construction measuring 54" in length to sit 36" above ground. These classic external wind posts are constructed of 8 gauge steel in 2-7/8" OD. The posts, external gears and handle are finished in forest green or black baked-on polyester powder coat finish to resist rust and increase durability. Integrated welded steel lacing rods are included for a professional net installation. The aluminum deluxe reel offers a smooth adjusting operation with a side mounted removable handle.

Corresponding Ground Sleeves:

24" PVC (GS-24PVC) (Item # 63164)
24" Aluminum (GS-24RD) (Item # 63171)

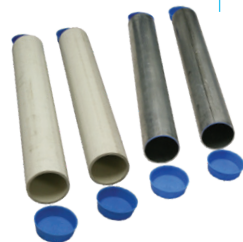

Pickleball Nets

These Douglas® nets meet the IFP and USA's requirements for official Pickleball and QuickStart Tennis sizes. Nets boast the same features as our Douglas® tennis nets and carry a 4 year warranty. Custom sizes are available.

JTN-30
36" h x 21'9" l (Item # 20105)

PN-30 -Optional shorter height
31" h x 21'9" l (Item # 20103)



Pickleball Premier™ SQ Surface Mount

Black (Item # 63080)

Easily convert existing tennis courts to pickleball courts with these easy-to-install surface mount posts. These 36" high posts boast all the features of the standard Premier™ SQ posts except they offer a heavy-duty bottom welded base plate to secure posts to the playing surface. The Premier™ SQ posts are constructed of heavy-duty 11-gauge steel. Posts are internally wound and feature a self-locking gear mechanism. Gears are constructed of plated steel and the small gear is case hardened. Gear housings and caps are made of cast aluminum alloy. Gear function is 30:1 to ensure a smooth, easy operation. Posts are finished in forest green or black baked-on polyester powder coat finish to resist rust and increase durability. Integrated welded steel lacing rods are included for a professional net installation. Gear plate cover and removable handle are chrome plated.



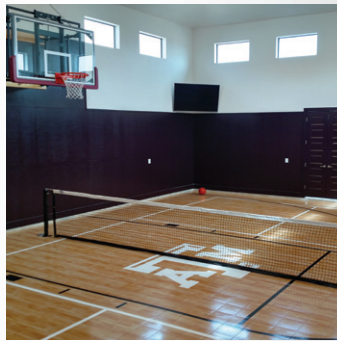
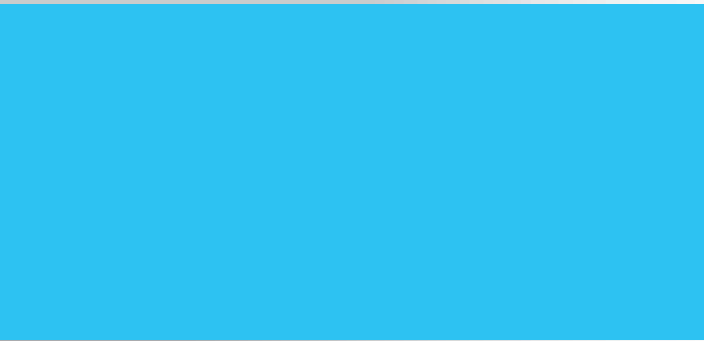
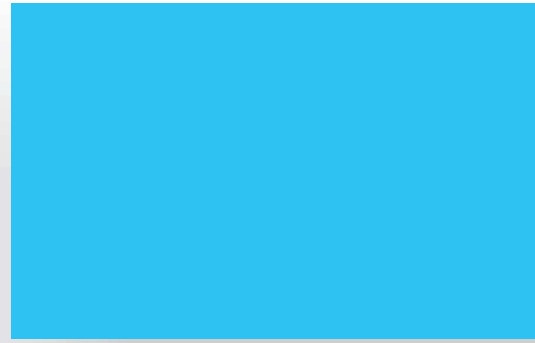

USA MANUFACTURER

1-800-553-8907
douglas-sports.com



TENNIS POSTS & NETS

quality USA manufactured

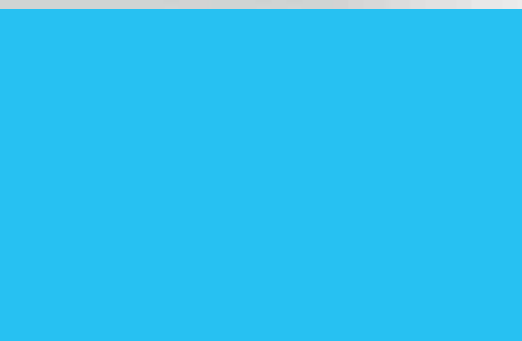
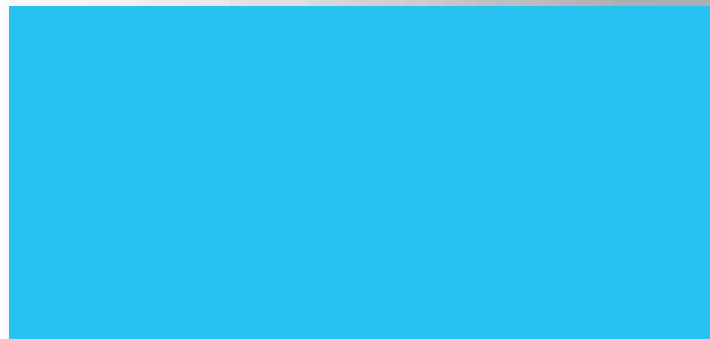

Tennis Nets and Accessories

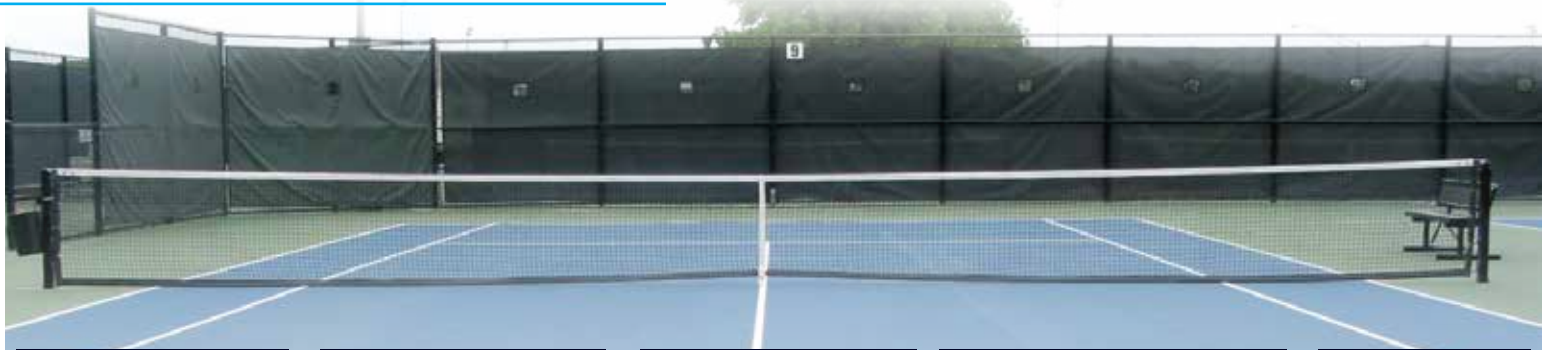

Consistent Quality

With Douglas® tennis nets, you get consistent, long-lasting performance. All Douglas® tennis nets meet USA requirements for official size -42' x 3'6". In addition, Douglas® nets carry a pro-rated warranty guaranteeing superior durability and longer net life. See for yourself why Douglas® nets are the brand of choice.

Netting

Netting is 1-3/4" square mesh braided solid core polyethylene unsurpassed for durability and weather resistance. Championship nets are made from 3.5mm with 325# break strength, Tournament and Recreation nets are made from 3.0mm with 285# break strength.

Headbands

Headbands are constructed using heavy-duty vinyl coated polyester or durable polyester webbing material that withstands the elements and won't shrink, rot or mold. Headbands are sewn to the netting with four rows of 32# white polyester thread -the heaviest in the industry.

Bottom & Side Pocket Tapes

Bottom and side pocket tapes are made of heavy-duty vinyl coated polyester and won't shrink, mildew or rot when exposed to the elements. Fiberglass dowels in the side pockets keep the net taut and attractive. Heavy duty brass grommets and lacing cord lets you pull the net snugly up to each post.

Cable

All Douglas® tennis nets come complete with a vinyl coated, 5/32" galvanized steel cable with break strength of 2300#. Both ends have double-swaged loops.



TN-45



TN-36T



TN-30



TN-28DM



TN-36DMT



TN-30DM

ITEM #	NET	HEADBAND		NETTING			WARRANTY
		MATERIAL	WEIGHT	SIZE	BREAK STRENGTH	TOP 6 ROWS DOUBLE MESH	
Professional Nets							
USA Manufactured by Douglas®							
20045	TN-45	Double thick 100% polyester	48 oz	3.5 mm	325 lb.	No	5 Year Warranty
20040	TN-40 (not pictured)	Vinyl Coated Polyester	36 oz.	3.5 mm	325 lb.	No	5 Year Warranty
Championship Nets							
30036T	TN-36 -tapered	Vinyl Coated Polyester, 2-ply	65 oz. (20 oz./sq. yd.)	3.5 mm	325 lb.	No	5 Year Warranty
30038TD	TN-36DMT -tapered	Vinyl Coated Polyester, 2-ply	65 oz. (20 oz./sq. yd.)	3.5 mm	325 lb.	Yes	5 Year Warranty
30060	TN-28DM	Durable Polyester Web	N/A	3.5 mm	325 lb.	Yes	5 Year Warranty
Tournament Nets							
30029	TN-30	Vinyl Coated Polyester	32 oz./sq. yd.	3.0 mm	285 lb.	No	4 Year Warranty
30030	TN-30DM -tapered	Vinyl Coated Polyester, 2-ply	65 oz. (20 oz./sq. yd.)	3.0 mm	285 lb.	Yes	4 Year Warranty

○ Sidewinder

2-7/8"

Green (Item # 63001)

Black (Item # 63003)

3-1/2"

Green (Item # 63005)

Black (Item # 63005B)

2 7/8"

3 1/2"

These recreational workhorse posts are designed for tough wear making them ideal for parks or school tennis courts.

These classic external wind posts are constructed of 8 gauge steel in either 2-7/8" or 3-1/2" OD. The posts, external gears and handle are finished in forest green or black baked-on polyester powder coat finish to resist rust and increase durability. Integrated welded steel lacing rods are included for a professional net installation. The aluminum deluxe reel offers a smooth adjusting operation with a side mounted removable handle.



Corresponding Ground Sleeves:

24" PVC (GS-24PVC) (Item # 63164)

24" Aluminum (GS-24RD) (Item # 63171)

24" Steel (GS-24) (Item # 63174)



○ DTP-37

Green (item # 63007)

Black (item # 63008)

3"

The dependable DTP-37 post is a sturdy design that has been a tennis court staple for decades.

These 3" OD posts are comprised of extra-heavy 7-gauge steel. Posts are internally wound and feature a self-locking gear mechanism. Gears are constructed of plated steel and the small gear is case hardened. Gear function is 30:1 to ensure a smooth, easy operation. The sleek gear housing and caps are made of cast aluminum alloy. Posts are finished in forest green or black baked-on polyester powder coat finish to resist rust and increase durability. Integrated welded steel lacing rods are included for a professional net installation. The side mounted removable handle is chrome plated.

Corresponding Ground Sleeves:

24" Steel (GS-24) (Item # 63424)



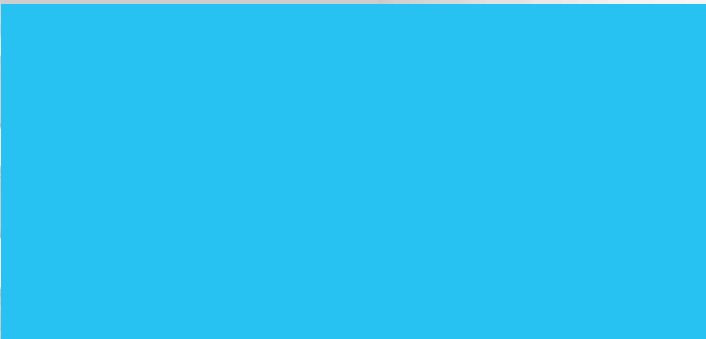

USA MANUFACTURER

1-800-553-8907
douglas-sports.com

CONSTRUCTION OF NEW TENNIS & PICKLEBALL COURTS AT MIKE FORD TENNIS CENTER

CITY OF FAIRHOPE - RECREATION DEPARTMENT

JULY 2024



INDEX TO SHEETS

<u>SHEET</u>	<u>DESCRIPTION</u>
1	Title
2	Overall Plan and Layout
3	Court & Sidewalk Details
4	Fence Details
5	Fence Details

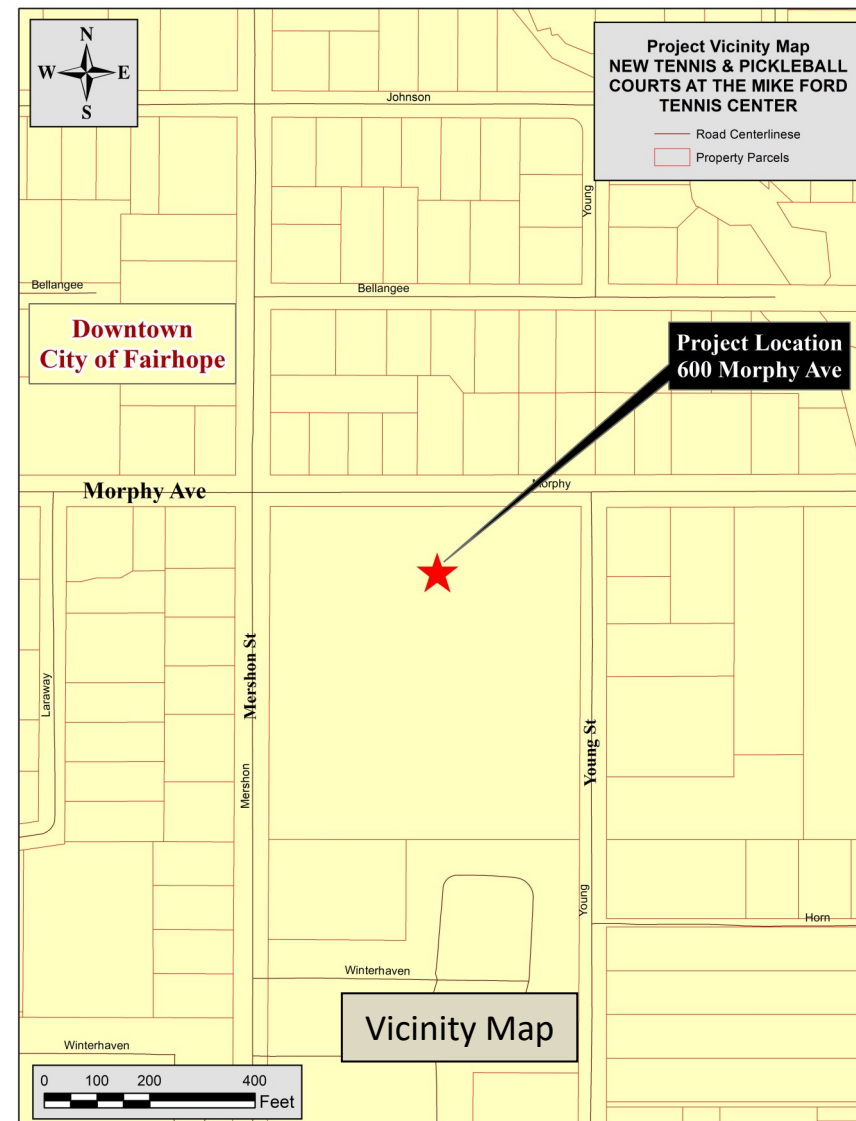

MAYOR

Sherry Sullivan

CITY COUNCIL

Kevin G. Boone

Corey Martin

Jack Burrell, ACOMO

Jimmy Conyers

Jay Robinson

CITY ENGINEER

Richard D. Johnson, PE

DIRECTOR OF PUBLIC WORKS

George Ladd

CITY CLERK

Lisa A. Hanks, MMC

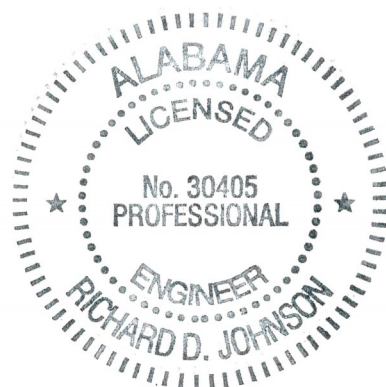

Richard D. Johnson
 Richard D. Johnson
 AL. REG. NO. 30405
 Project Engineer

07-02-2024
 Date

Project: 2024-PWI 002
Bid Set Drawings

MORPHY AVE

MERSHON ST

FORD TENNIS CENTER AT STIMPSON FIELD



Legend

- ## T.O.C - Elev @ Top of finished court
- Existing grade Elev

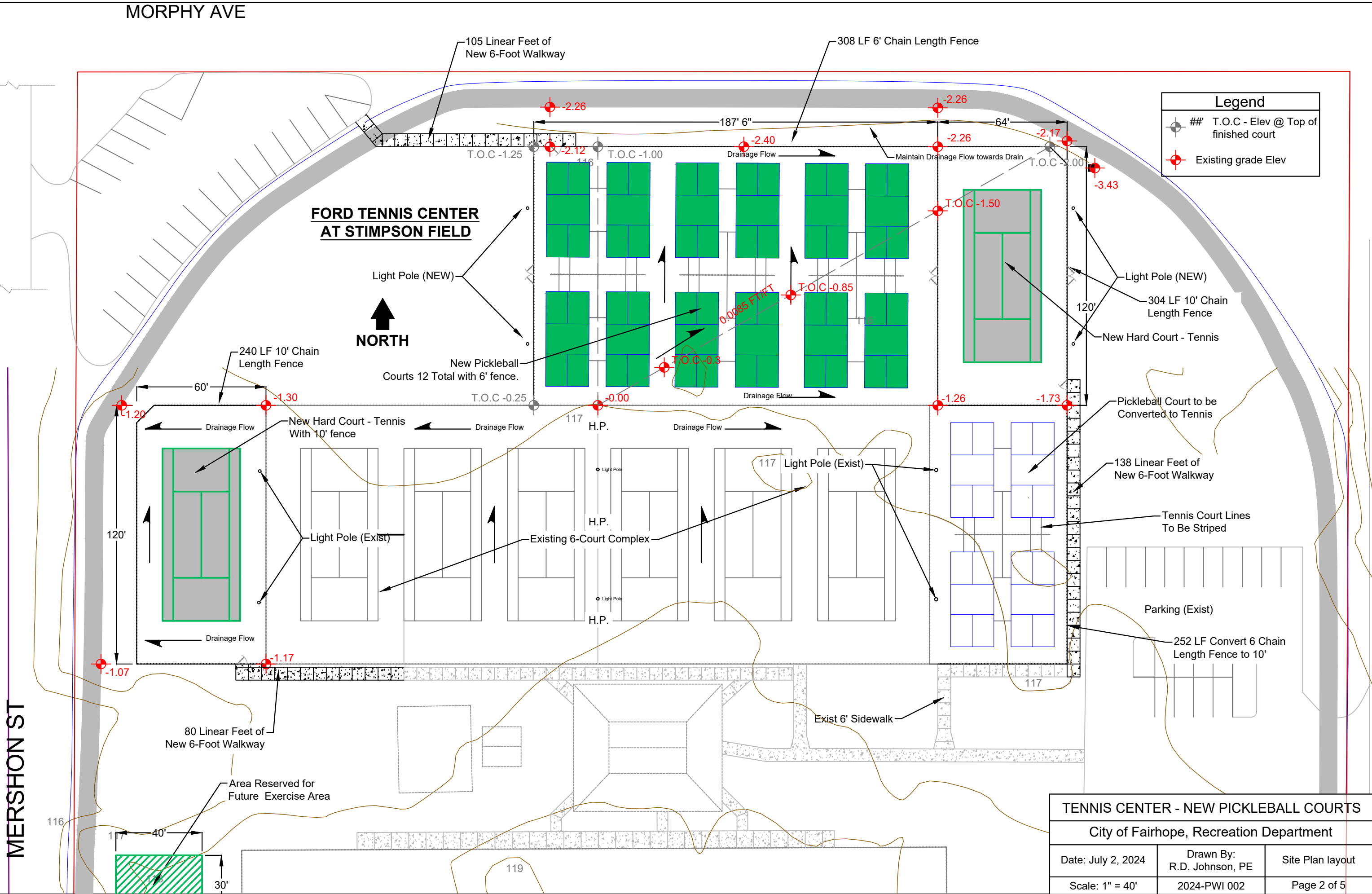

TENNIS CENTER - NEW PICKLEBALL COURTS		
City of Fairhope, Recreation Department		
Date: July 2, 2024	Drawn By: R.D. Johnson, PE	Site Plan layout
Scale: 1" = 40'	2024-PWI 002	Page 2 of 5

STANDARD PICKLEBALL COURT LAYOUT

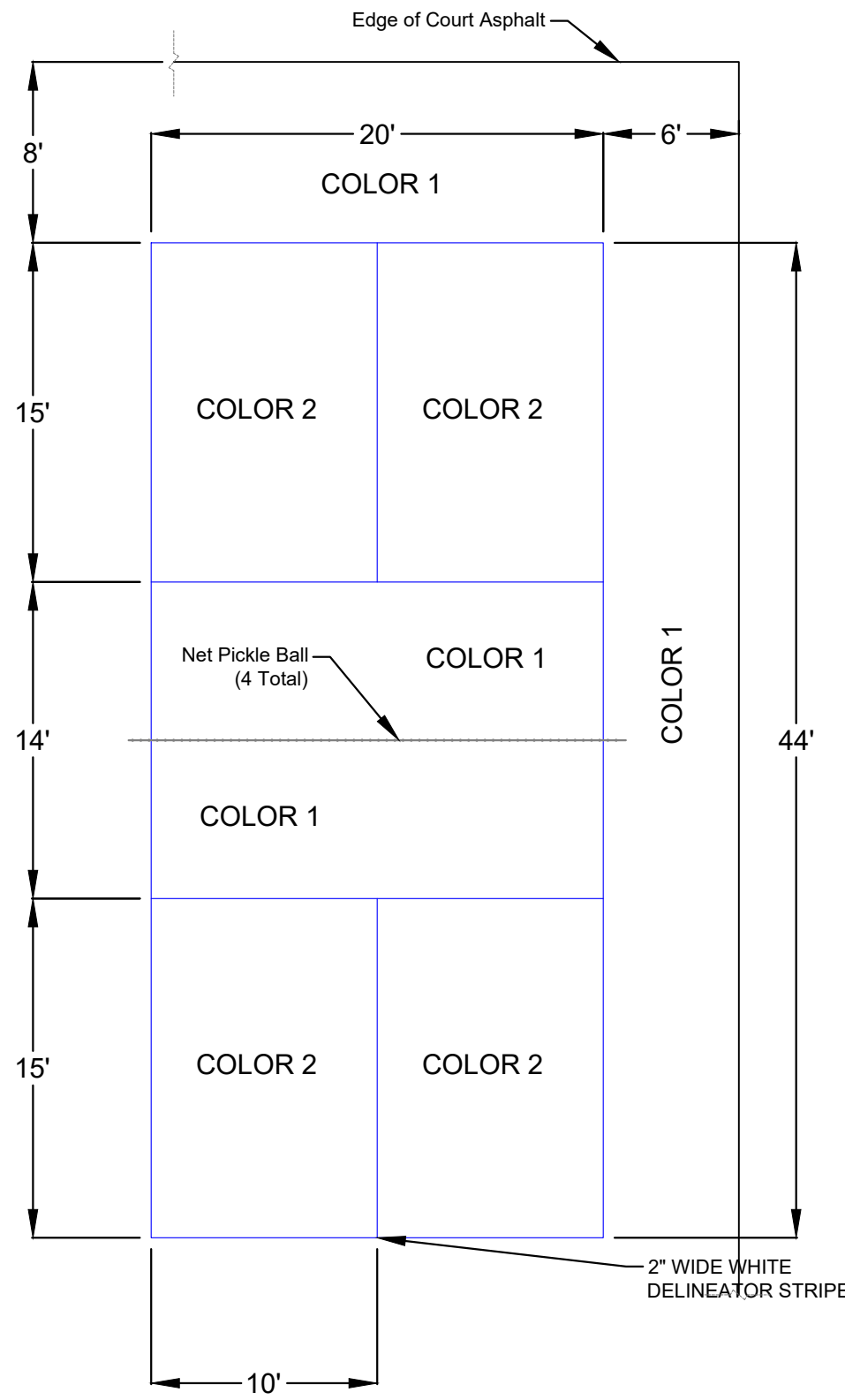

Note: Court Colors to be selected by Owner from Manufacturers Standard Colors

TYPICAL SINGLE COURT STRIPING & COATING PLAN
NOT TO SCALE

TYPICAL ASPHALT COURT SECTION

NOT TO SCALE

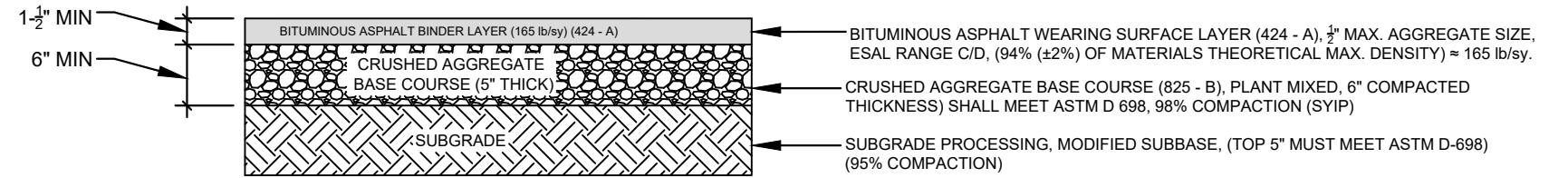

- NOTE:
1. Contractor shall remove sod and the topsoil to eliminate organic matter from subgrade
 2. Excavation to be backfilled with select fill (A-2-4) to required grade elevation
 3. Post wearing surface placement, low spots and uneven surfaces shall be addressed using a patch binder mix - See Specifications

TYPICAL SIDEWALK DETAILS & NOTES

NOT TO SCALE

SIDEWALK DETAIL NOTES:

1. ALL SIDEWALKS SHALL HAVE A MAXIMUM 2.0% CROSS SLOPE.
2. ALL SIDEWALKS SHALL RECEIVE A BROOM FINISH.
3. ALL SIDEWALK EDGES SHALL HAVE 1/2" RADIUS EDGE.
4. SIDEWALKS SHALL BE CONSTRUCTED WITH CONCRETE THAT HAS A MINIMUM TWENTY EIGHT (28) DAY COMPRESSIVE STRENGTH OF THREE THOUSAND POUNDS PER SQUARE INCH (3000 PSI).
5. EXPANSION JOINTS SHALL BE A MINIMUM OF 1/2" AND EXTEND THE FULL DEPTH OF THE CONCRETE. EXPANSION JOINT MATERIAL SHALL MEET AASHTO M213 FOR AN ASPHALTIC FIBER EXPANSION JOINT MATERIAL. OTHER ALLOWABLE EXPANSION JOINT MATERIAL IS 1"x4" PRESSURE TREATED PINE WITH NAILS DRIVEN THROUGH EACH SIDE TO PREVENT THE BOARD FROM BEING PUSHED OUT OF JOINT.
6. CONTRACTION JOINTS SHALL BE PLACED AT 6 FOOT INTERVALS.
7. WHEN PLACING SIDEWALK AGAINST AN EXISTING CONC. STRUCTURE WHERE IT IS DESIRABLE THAT THE SIDEWALK REMAIN FLUSH, THE SIDEWALK SHALL BE DOWELED INTO THE STRUCTURE.
8. ALL SIDEWALK BASE SHALL BE PLACED ON FIRM, STABLE SUBGRADE. BASE SHALL BE 2"-4" OF COMPACTED COURSE SAND.
9. CONTACT PUBLIC WORKS 24 HOURS PRIOR TO ANY PLACEMENT OF CONCRETE FOR AN INSPECTION.
10. SIDEWALK ALIGNMENT AND CLEAR SPACE WIDTH MAY BE MODIFIED AS EXISTING FIELD CONDITIONS DICTATE - ALL SUBJECT TO THE APPROVAL OF THE DIRECTOR OF PUBLIC WORKS.

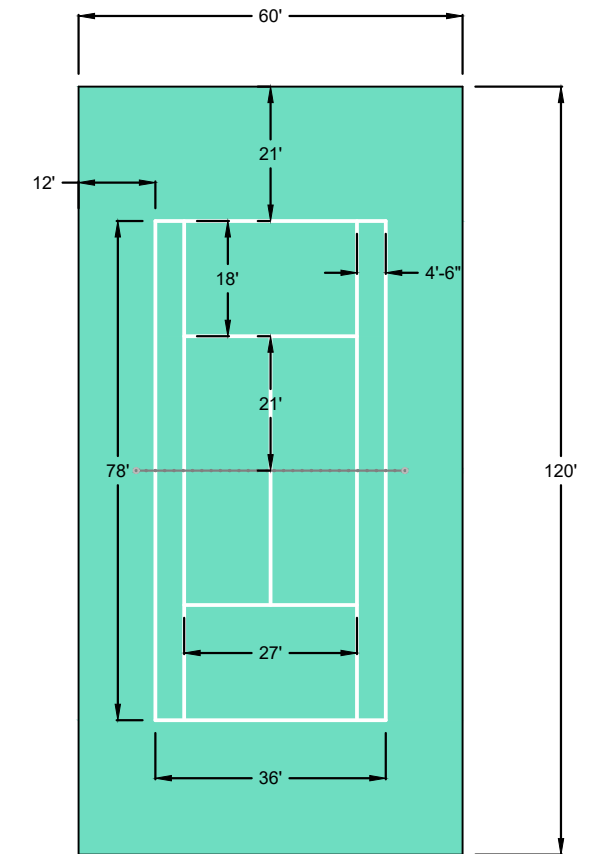
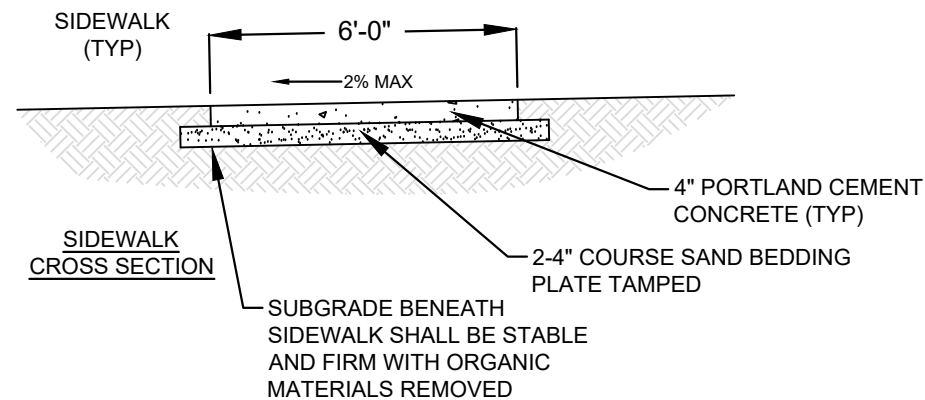
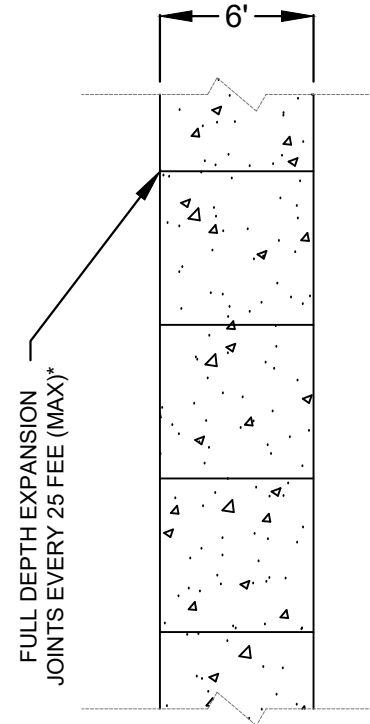

STANDARD TENNIS COURT LAYOUT

TENNIS CENTER - NEW PICKLEBALL COURT		
City of Fairhope, Recreation Department		
Date: July 2, 2024	Drawn By: R.D. Johnson, PE	Details
Scale: N.T.S.	2019-PWI 013	Page 3 of 5

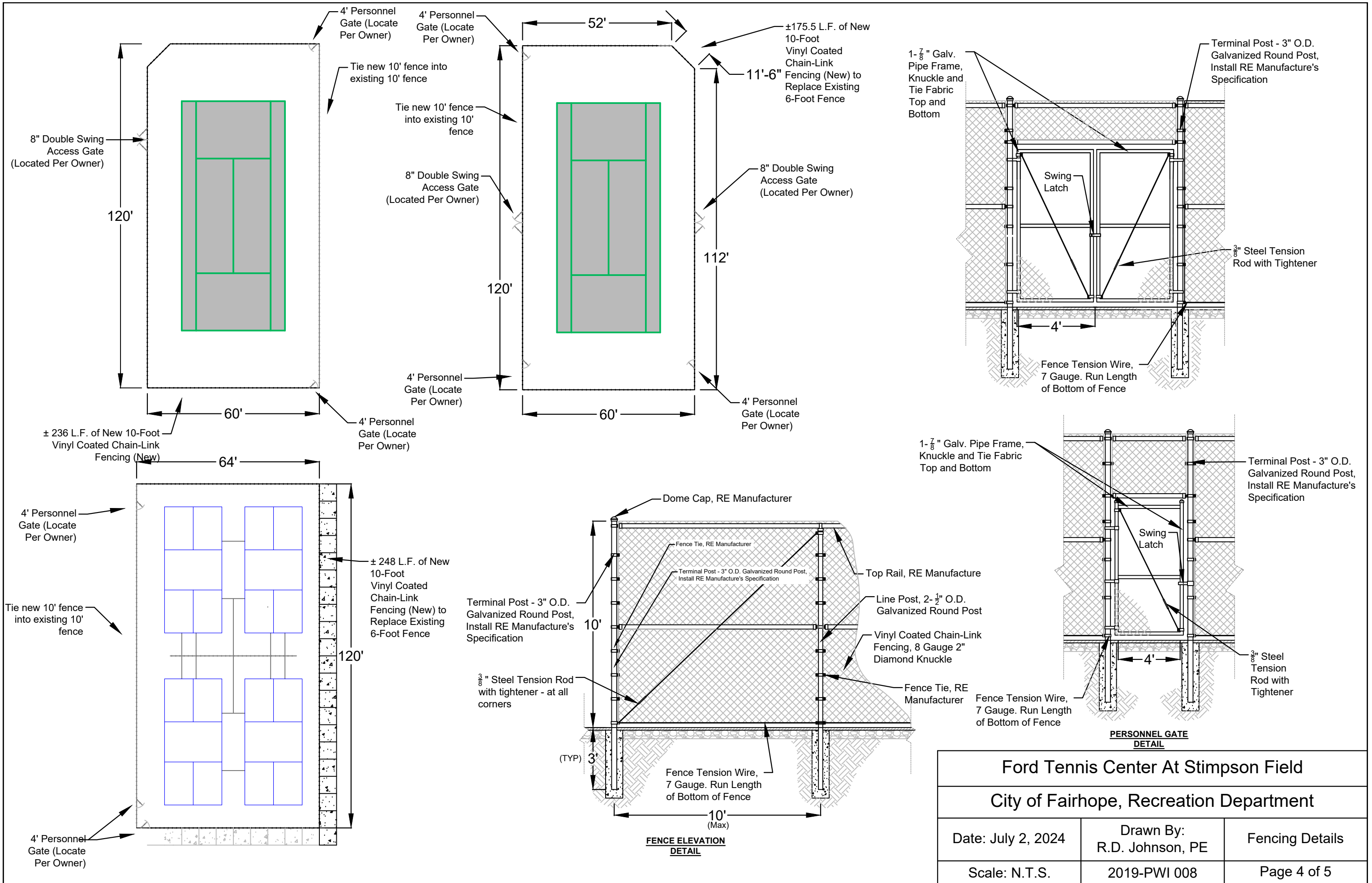

Ford Tennis Center At Stimpson Field		
City of Fairhope, Recreation Department		
Date: July 2, 2024	Drawn By: R.D. Johnson, PE	Fencing Details
Scale: N.T.S.	2019-PWI 008	Page 4 of 5

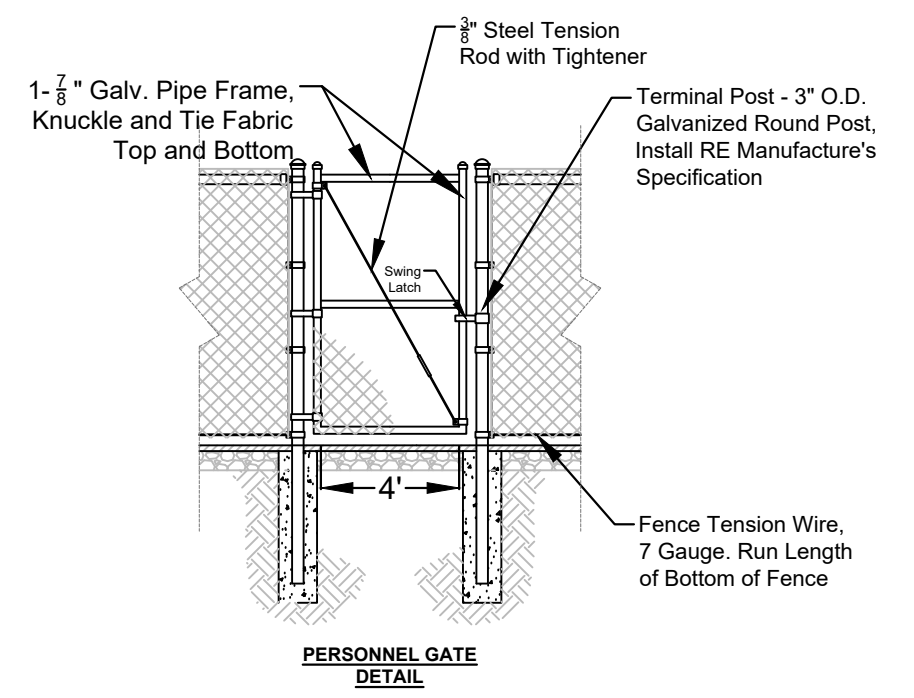
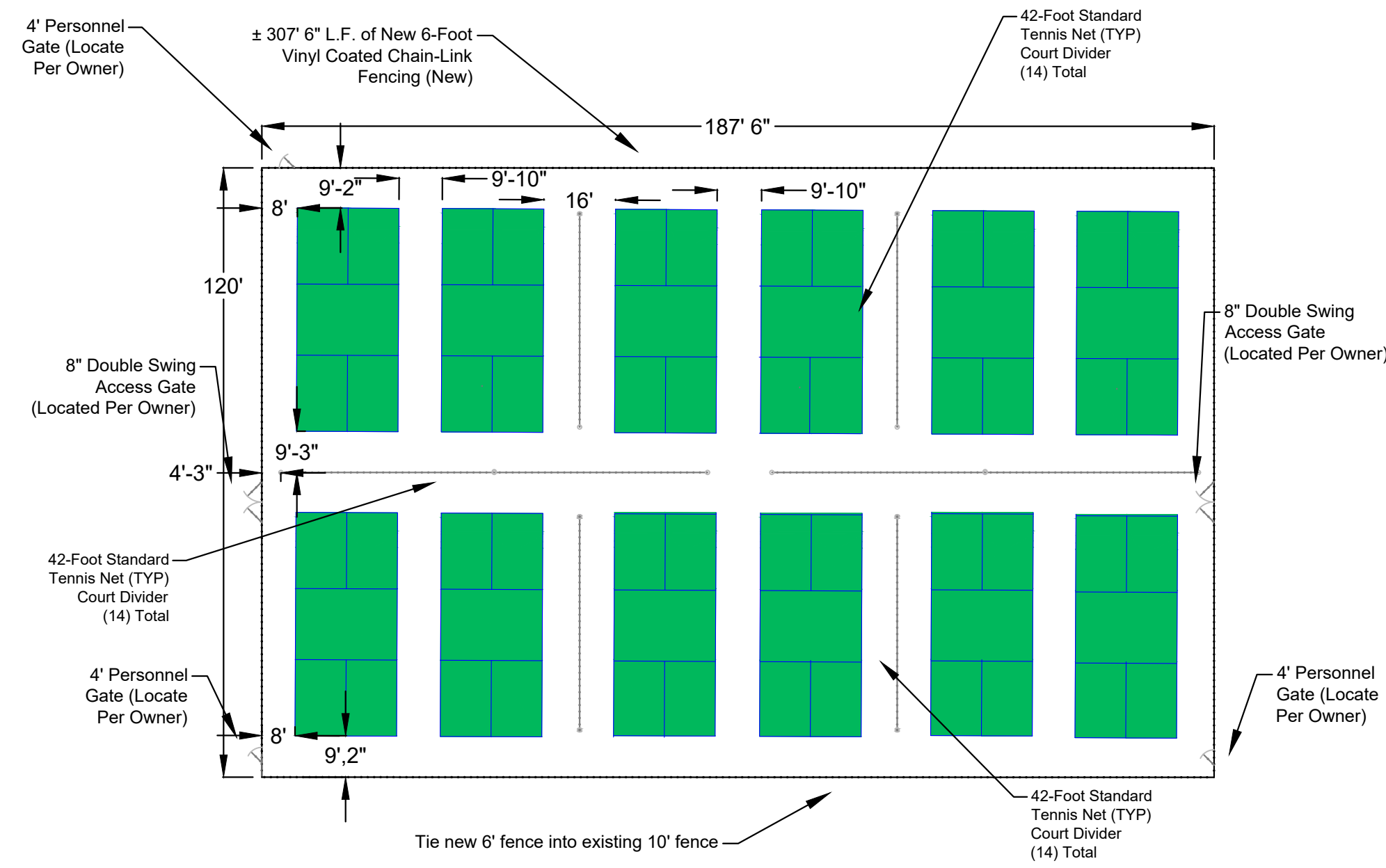
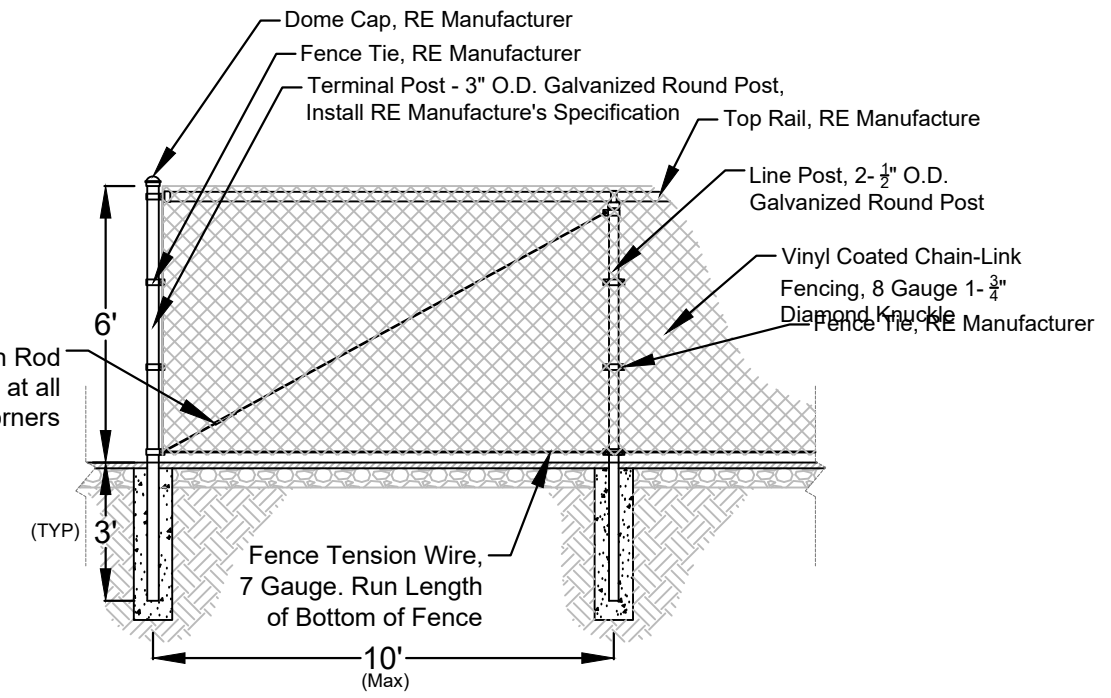
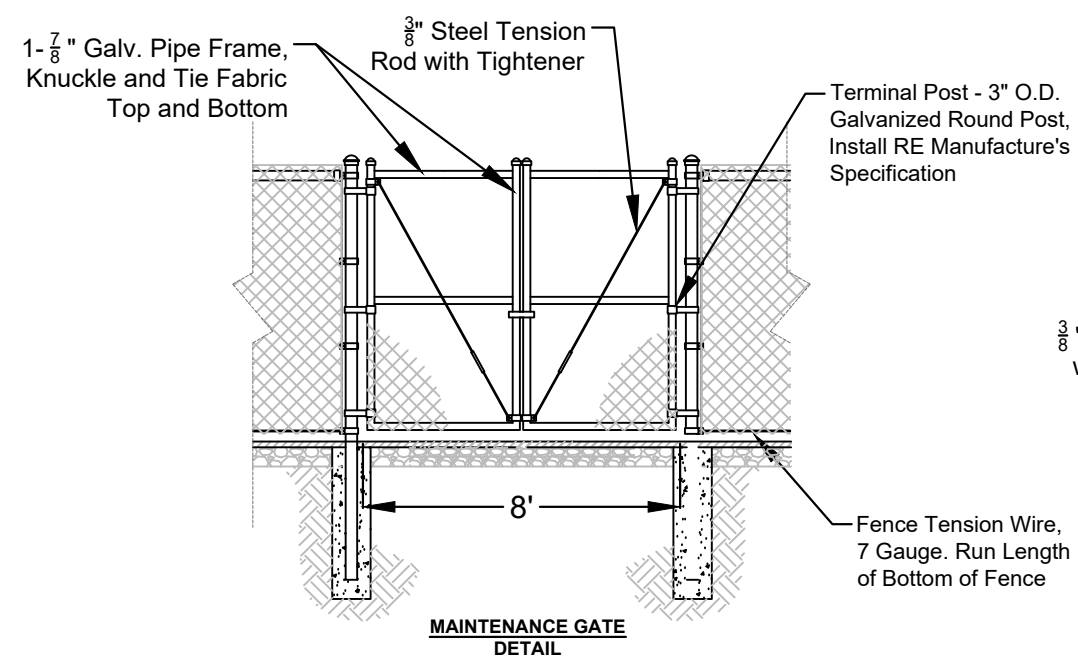

TENNIS CENTER - NEW PICKLEBALL COURT		
City of Fairhope, Recreation Department		
Date: April 10, 2019	Drawn By: R.D. Johnson, PE	Fencing Details
Scale: N.T.S.	2019-PWI 013	Page 5 of 5