



**CITY OF FAIRHOPE
INVITATION TO BID**

SEALED BIDS will be received by the City of Fairhope of Baldwin County, Alabama, in the City of Fairhope's City Services and Public Utilities Building located at, 555 South Section St. Fairhope, Alabama, until 10:00 A.M. Thursday, June 20, 2024, and then publicly opened thereafter, for furnishing all labor and materials, and performing all work required by the City of Fairhope and described as follows:

**Bid Number 24-049
D'Olive Creek Gas Main Replacement**

The City of Fairhope is requesting responses from qualified contractors to provide all material, equipment, labor and incidentals to replace the natural gas main at D'Olive Creek/Alligator Boardwalk Bridge in Daphne, Alabama. The Contractor is to replace the steel gas main from the Southeast corner of Highway 98 and Highway 90 to approximately 200' South of D'Olive Creek, into the designated exit put and tie in area. The gas main will be replaced with approximately 1,000' of dual coat (brown) 6" steel gas pipe via directional drilling. The City will provide the 6" steel gas pipe for this project. The Contractor will provide all other materials and equipment required for this project.

Bid documents will be posted on the City of Fairhope Website: www.FairhopeAL.gov or a copy may be obtained by e-mailing: Purchasing@FairhopeAL.gov. Specifications are on file and may be seen in the Purchasing Department of the City of Fairhope, Alabama, 555 S. Section Street. Prior to opening, Bid packages may be picked up at that location during normal operation, between 7:00 am and 4:00 pm local time.

Questions or comments pertaining to this bid must be presented in writing, sent as e-mail to the attention of the Purchasing Manager, Erin Wolfe, 555 South Section St., Fairhope, AL 36532, e-mail: Purchasing@FairhopeAL.gov, by Friday, June 14, 2024, at 11:00 A.M. or will be forever waived.

There will be a **MANDATORY** pre-bid meeting on Wednesday, June 12, 2024, at 10:00 A.M. at the City Services and Public Utilities Building located at 555 South Section Street, Fairhope, AL.

The City of Fairhope is an Equal Opportunity Employer and requires that all **BIDDERS** comply with the Equal Employment Opportunity laws and the provisions of the CONTRACT Documents in this regard. The **CITY** also encourages and supports the utilization of Minority Business Enterprises on this and all public bids.

All bids must be on blank bid forms provided in the Bid Documents. All bids, with their guarantee (when required), must be enclosed in a sealed, opaque envelope, clearly identified on the outside as a "**Sealed Bid**" with **Item Name, Bid Number, City of Fairhope's Name and Address and CONTRACTOR's Name and Address**. Each bid must be in a separate envelope. Bids made out in pencil will not be accepted. Failure to observe the instructions contained herein will constitute grounds for rejection of your bid. The **City** reserves the right to accept or reject all bids or any portion thereof, and to waive informalities and to furnish any item of material or work to change the amount of the CONTRACT, whichever is in the best interest of the City of Fairhope.

No bids will be considered unless the **CONTRACTOR**, whether resident or non-resident of Alabama, is properly qualified to submit a proposal for this type of work in accordance with all applicable laws of the State of Alabama. Where applicable, this shall include evidence of holding a current license from the State Licensing board for General BIDDERS, Montgomery, Alabama, as required by Chapter 8 of Title 34, of the Code of Alabama, 1975. In addition, the Awarded Vendor, if non-resident of the State, and if a corporation, shall show evidence of having qualified with the Secretary of State to do business in the State of Alabama. **CONTRACTOR** must have a current business license or purchase a business license with the City of Fairhope prior to work performed. No bids shall be withdrawn for the period of thirty (30) days subsequent to the opening of proposals without the consent of the City of Fairhope, Baldwin County, Alabama. Once completed, a tabulation of the responsive and responsible bids will be available for public viewing by visiting the following web address: www.FairhopeAL.gov.



**INVITATION TO BID
NO. 24-049
D'Olive Creek Gas Main Replacement**

**CITY OF FAIRHOPE
SHERRY SULLIVAN, MAYOR**

TABLE OF CONTENTS

Invitation and Instruction to Bidders.....	I
Scope of Work.....	II
Bid Response Form.....	III
Contractor Information.....	IV
Insurance.....	V
Sample Contract.....	VI
Standard Terms and Conditions.....	VII
Alabama Immigration Act Contract Requirements.....	VIII
Invitation Summary.....	IX
Bid Bond.....	X
Performance Bond.....	XI
Labor and Materials Bond.....	XII
Closeout Documents.....	XIII
Bore Path Aerial Photograph.....	Attachment
Bid Set Drawings.....	Attachment

**ITEM I
INVITATION AND INSTRUCTIONS TO BIDDERS**

1.00 BID INVITATION

Notice is hereby given that the **City of Fairhope ("CITY")** will receive bids on the project described herein. Qualified **BIDDERS** are invited to bid on this CONTRACT.

1.01 BID NO.: 24-049
NAME: D'Olive Creek Gas Main Replacement
LOCATION: Daphne, AL

1.02 SUMMARY

The City of Fairhope is requesting responses from qualified contractors to provide all material, equipment, labor and incidentals to replace the natural gas main at D'Olive Creek/Alligator Boardwalk Bridge in Daphne, Alabama. The Contractor is to replace the steel gas main from the Southeast corner of Highway 98 and Highway 90 to approximately 200' South of D'Olive Creek, into the designated exit put and tie in area. The gas main will be replaced with approximately 1,000' of dual coat (brown) 6" steel gas pipe via directional drilling.

1.03 BID DEADLINE

Bids will be received until **10:00 A.M. local time, Thursday, June 20, 2024**, at the City Services and Public Utilities Building, 555 South Section St., Fairhope, Alabama, and publicly opened shortly thereafter.

1.04 AVAILABILITY OF DOCUMENTS

Bid Documents may be obtained on the City's website at www.FairhopeAL.gov/departments/purchasing/bids or at the City Services and Public Utilities Building, 555 South Section Street., Fairhope, Alabama. One set of Bid Documents can be obtained free of charge.

1.05 INQUIRIES

Questions or comments pertaining to this bid must be presented in writing, sent as e-mail to the attention of the Purchasing Manager, Erin Wolfe, 555 South Section St., Fairhope, AL 36532, e-mail: Purchasing@FairhopeAL.gov, by Friday, June 14, 2024, at 11:00 A.M. or will be forever waived.

1.06 SITE EXAMINATION

There will be a **MANDATORY** pre-bid meeting on Wednesday, June 12, 2024, at 10:00 A.M. at the City Services and Public Utilities Building located at 555 South Section Street, Fairhope, AL. This mandatory pre-bid meeting will serve as an opportunity for potential bidders to engage project stakeholders, review plans and ask questions.

The City of Fairhope will not furnish any labor, material, or supplies unless specifically stated in the CONTRACT Documents. **BIDDERS** must be properly licensed to perform the work as outlined in the Scope of Work. Awarded Vendor must have a current business license or purchase a business license with the City of Fairhope prior to bid being awarded.

Except for CONTRACTS funded in whole or in part by funds received from a federal agency, preference shall be given to resident **BIDDERS** on the same basis as the nonresident **BIDDERS** state awards CONTRACT to Alabama **BIDDERS** bidding under similar circumstances. Therefore, non-resident **BIDDERS** shall submit with their bid a written opinion of an attorney at law licensed to practice law in the non-resident **BIDDERS** state of domicile as to preferences granted by that state to entities doing business in that state when letting public contracts.

1.07 **BID SECURITY**

Bids shall be accompanied by a Bid Security equal to 5% (percent) of the bid price, but in no event more than \$10,000.00. Bid Security shall be in the form of a Bid Bond or a cashier's check payable to The City of Fairhope. No Bid Security is required on bids less than \$10,000.00.

1.08 **PERFORMANCE ASSURANCE AND INSURANCE**

The **BIDDER** to whom award is made shall provide a Performance Bond equal to 100% of the CONTRACT Amount and a Labor and Material Bond equal to 50% of the CONTRACT amount.

The accepted **BIDDER** shall also provide insurance as required in ITEM V.

1.09 **DURATION OF OFFER**

Bids may be withdrawn in written or telegraphic request received from **BIDDER** prior to the time fixed for opening. No bid shall be withdrawn for a period of sixty (60) days subsequent to the opening of bids without the consent of the City Council of the City of Fairhope.

1.10 **EQUAL OPPORTUNITY**

The City of Fairhope is an Equal Opportunity Employer and requires that all **BIDDERS** comply with the Equal Employment Opportunity laws and the provisions of the CONTRACT Documents in this regard. The City of Fairhope also encourages and supports the utilization of Minority Business Enterprises on this and all public bids.

1.11 **BID SUBMISSION AND PREPARATION**

Sealed Bids, signed, executed, and dated, will be received by the City of Fairhope as noted in section 1.03 above. Submit one copy of the executed offer on the Bid Form provided, signed, and with the required Bid Security. **The bid shall be enclosed in a sealed opaque envelope approximately 9x12 inches or larger, clearly identified on the outside as a SEALED BID with the BID NAME, BID NUMBER, CITY'S NAME AND ADDRESS, CONTRACTOR'S NAME AND ADDRESS.**

Forms furnished, or copies thereof, shall be used, and strict compliance with the requirements of the invitation, these instructions, and the instructions printed on the forms is necessary. Special care should be exercised in the preparation of bids. **BIDDERS** must make their own estimates of the facilities and difficulties attending the performance of the proposed CONTRACT, including local conditions, uncertainty of weather, and all other contingencies. All designations and prices shall be fully and clearly set forth. The proper space in the bid and guaranty forms shall be suitably filled in.

Fill in all blanks on the bid form with non-erasable ink or type. Erasers or other changes must be explained or noted over the signature of the **BIDDER**.

The Bid Form may have a Contingency Allowance listed. Add this amount to the Base Bid to derive the Total Bid. The Contingency Allowance covers unforeseen conditions and shall not be used by the **BIDDER** without the written authorization of the **CITY**. At the conclusion of the project, the unused portion of the Contingency Allowance shall revert to the **CITY**.

Each bid must give the full business address of the **BIDDER** and must be signed by him with his usual signature. Bids by partnerships must furnish the full names of all partners and must be signed with the partnership name by one of the members of the partnership, or by an authorized representative, followed by the signature and designation of the person signing. Bids by corporations must be signed with the legal name of the corporation followed by the name of the State of Incorporation and by the signature and designation of the president, secretary, or other person authorized to bind it in the matter. The name of each person shall also be typed or printed below the signature. A bid by a person who affixes to this signature the word "president," "secretary," "agent," or other designation without disclosing his principal, may be held to be the bid of the individual signing. When requested by the **CITY** satisfactory evidence of the authority of the officer signing in behalf of the corporation shall be furnished.

Each project will be bid separately unless otherwise expressly requested in the CONTRACT document. Combination bids, that is bids on separate projects lumped together as a single bid or on all or none basis, will not be accepted unless the CONTRACT document expressly requests or permits same.

1.12 **BID INELIGIBILITY**

Bids that contain irregularities of any kind may be declared unacceptable at the discretion of the **CITY**. The **CITY** may waive any irregularities and may reject any or all bids. Bids received after the deadline will be returned to the **BIDDER** unopened.

1.13 **CONTRACT TIME**

The **BIDDER** agrees to provide to provide all material, equipment, labor and incidentals to replace the natural gas main at D'Olive Creek/Alligator Boardwalk Bridge in Daphne, Alabama, in forty-five (45) working days allowed for work, no exceptions for holidays, following a 15-day Notice to Proceed Period.

1.14 **INQUIRIES/ADDENDA**

All Addenda are part of the CONTRACT Documents. Include resultant costs in the Bid. Addenda will be issued by E-MAIL and posted on the City's website: www.FairhopeAL.gov. It is the responsibility of the **BIDDER** to verify that all Addenda have been received.

Questions or comments pertaining to this bid must be presented in writing, sent via email Purchasing@FairhopeAL.gov by Friday, June 14, 2024, at 11:00 A.M. or will be forever waived.

1.15 **BID ACCEPTANCE**

Bid with lowest Total Bid amount from a responsive and responsible **BIDDER** may be accepted if within the **CONTRACT** Budget. In the event that alternates are listed on the Bid Form, the lowest combination of Total Bid and Alternate Bids accepted by the **CITY** shall be the accepted bid. Alternates shall be awarded in the order in which they are listed on the Bid Form.

1.16 **BIDDERS INTERESTED IN MORE THAN ONE BID**

If more than one bid is offered by any one party, by or in a name of his clerk, partner, corporation in which he has a substantial interest, or in which he is an officer, or other person, all such bids may be rejected. A party who has quoted prices on materials to a **BIDDER** is not thereby disqualified from quoting prices to other **BIDDERS** or from submitting a bid directly for the materials or work. The **CITY** reserves the right to determine in its discretion whether the provisions of this clause have been violated by any **BIDDER**.

1.17 **ERRORS IN BIDS**

BIDDERS or their authorized agents are expected to examine the maps, drawings, specifications and all other instructions pertaining to the work, which will be open to their inspection. Failure to do so will be at the **BIDDER'S** own risk. In case of error, in the extension of prices, the unit price will govern.

1.18 **CONTRACT AND BOND**

The **BIDDER** to whom award is made must, when requested, enter into written **CONTRACT** on the standard form as set out herein, with satisfactory security in the amount required, within the period specified, or, if no period be specified, within 15 days after the required forms are presented to him for signature.

1.19 **COLLUSION**

If there is any reason for believing that collusion exists among the **BIDDERS** any or all bids may be rejected, and those participating in such collusion may be barred from submitting bids on the same or other work with the **CITY**.

1.20 **SUBLETTING OR ASSIGNING OF CONTRACT**

Limitations: The **CONTRACTOR** shall not sublet, assign, transfer, convey, sell, or otherwise dispose of any portion of the **CONTRACT**, his right, title or interest therein, or his power to execute such **CONTRACT**, to any person, firm or corporation without written consent of the **CITY**, and such written consent shall not be construed to relieve the **BIDDER** of any responsibility for the fulfillment of the **CONTRACT**. Unless otherwise stipulated in the proposal or special provisions, the **BIDDER** shall

perform with his own organization, and with the assistance of workmen under his immediate superintendence and reported on his payroll, all CONTRACT work of a value not less than 50 percent of the total CONTRACT amount, except that any items designated in the CONTRACT as "Specialty Items" so performed by SUB-CONTRACT may be deducted from the total CONTRACT amount before computing the amount of work required to be performed by the **BIDDER** with his own organization.

SUB-CONTRACTOR'S Status:

A **SUB-CONTRACTOR** shall be recognized only in the capacity of an employee or agent of the **CONTRACTOR** and the **CONTRACTOR** will be responsible to the **CITY** for all of the **SUB-CONTRACTOR's** work, including failures or omissions; and his removal may be required by the Project Manager, as in the case of an employee.

1.21 **PROSECUTION OF WORK**

The **BIDDER** shall prosecute the work continuously and diligently in the order and manner set out in his schedule as approved by the **CITY**. He shall provide sufficient satisfactory materials, labor, and equipment to ensure that the work will be completed in a satisfactory manner within the time specified in the CONTRACT.

Should the **BIDDERS** fail to maintain a satisfactory rate of progress, the **CITY** may require that additional forces and/or equipment be placed on the work to bring the project up to schedule and maintain it at that level.

Should the **BIDDER** fail to furnish sufficient satisfactory equipment and/or labor for maintaining the quality and progress of the work at satisfactory level, the **CITY** may withhold all estimates that may become due until satisfactory quality and progress are maintained; or the CONTRACT may be annulled.

**ITEM II
SCOPE OF WORK**

**Bid No. 24-049
D'Olive Creek Gas Main Replacement**

SCOPE OF WORK

The City of Fairhope is requesting responses from qualified contractors to provide all material, equipment, labor and incidentals to replace the natural gas main at D'Olive Creek/Alligator Boardwalk Bridge in Daphne, Alabama. The Contractor is to replace the steel gas main from the Southeast corner of Highway 98 and Highway 90 to approximately 200' South of D'Olive Creek, into the designated exit put and tie in area. The gas main will be replaced with approximately 1,000' of dual coat (brown) 6" steel gas pipe via directional drilling. See attached map for proposed bore path. **All work shall be done following the specifications as listed in the attached Bid Set Drawings.**

Bidding Contractors shall field-verify all conditions prior to submittal.

Expected materials Contractor shall provide, but are not limited to:

- 6" Bottom Outs Quantity: 2
- 6" 90 Deg Elbow Quantity: 4
- 45 Deg Elbow Quantity: 6
- 22.5 Deg Elbow Quantity: 6
- 6" Caps Quantity: 7
- 6" Tee Quantity: 1
- 6" Valve Quantity: 2
- Valve Boxes, Extensions and Lids

City will provide the approximately 1,000' of 6" pipe for this project. Contractor will provide all other materials and equipment. All materials and equipment shall be included in the lump sum cost submitted.

All pipe shall be installed a minimum of 10' below the creek bottom.

Contractor will be responsible for disconnect and reconnection. Disconnect will be via weld on bottom fittings on each end. After the welding, the Contractor will need to "tap" the gas pipe in those fittings, then install a "stopper" to stop gas flow in order to cut the line and weld a new line in. The Contractor will fill the old, abandoned line with grout.

Contractor will tie in the new line by welding new steel pipe and fittings to the bottom out fittings.

Ditch and Creek Crossing:

At water crossings, creeks, or streams, the Contractor may use dikes, cofferdams, culverts, or pilings to separate the work area from the flowing stream. The minimum depth of the pipe below the existing stream shall be ten (10) feet. Any slope draining into the project crossing greater than 10 percent will have appropriate erosion control measures to minimize erosion. Banks of the crossing shall be restored to their original condition and to prevent erosion, rip-rap material may be required.

Temporary measures for erosion control include mechanical barriers to confine sediment and block its entry into the waterway, and temporary seeding methods to revegetate raw earth left exposed during construction. Permanent measures for erosion control involve grading to previous contours, permanent revegetation methods, and follow-up inspections to monitor the success of seeding, with additional seeding if necessary. If temporary straw bale filters are chosen for the project, bales shall be embedded at least four inches into the soil, and each bale firmly held in place by two stakes driven at least 1 ½ feet into the ground. All excavation work shall conform to the terms if federal, state, and local permits and Right-of-Way easements.

Contractor will install erosion and sediment control devices as outlined in the Alabama Handbook for Erosion Control, Sediment Control and Stormwater Management on Construction Sites and Urban Areas, latest edition, published by the Alabama Soil and Water Conservation Committee. Temporary silt fences that have been properly installed will be entrenched at the bottom a minimum of 4" with properly compacted soils backfilled into the trench. Properly sited silt fences will be placed down slope of loose or denuded soil and will extend the length of the exposed soils and have both ends running back up the slopes to entrap water and sediment. Proper installation and proper location for silt fences will be as defined by the permitting agency."

The Contractor is solely responsible for the locating all existing Utilities and Services. Failure of the Contractor to locate any utility does not justify additional payment to the Contractor if said utility is damaged. The Contractor must notify the utility companies involved prior to starting construction and shall make every effort not to damage any utilities. If utilities are damaged by the Contractor, the Contractor must pay all expenses incurred in the repair at no cost to the Owner or his representatives.

CRITICAL TIMELINES:

- 15-day Notice to Proceed Period
- 45 Working Days allowed for work (no exceptions for holidays)

1. **SAFETY AND HEALTH REGULATIONS FOR CONSTRUCTION:** The Contractor shall comply with the Department of Labor Safety and Health Regulations for construction promulgated under the Occupational Safety and Health Act of 1970 (PL-596) and under Section 107 of the Contract Work Hours and Safety Standards Act (PL-91-54).

The contractor alone shall be responsible for the safety, efficiency, and adequacy of his plant, appliances, and methods, and for any damage which may result from their failure or their improper construction, maintenance, or operations.

2. **PROJECT SITE:** The Contractor shall keep the project site clean at all times. No loose dirt or stockpiles shall be left in areas other than those areas approved by the City. The City may require the Contractor to clean up any portion of the Project as deemed necessary.
3. **PROTECTION OF LIVES AND HEALTH:** "The Contractor shall exercise proper precaution at all times for the protection of persons and property and shall be responsible for all damages to persons or property, either on or off the site, which occur as a result of his prosecution of the work. The safety provisions of applicable laws and building and construction codes, in addition to specific safety and health regulations described by Chapter XIII, Bureau of Labor Standards, Department of Labor, Part 1518, Safety and Health Regulations for Construction, as outlined in the Federal Register, Volume 36, No. 75, Saturday, April 17, 1971. Title 29 - LABOR, shall be observed and the Contractor shall take or cause to be taken, such additional safety and health measures as the Contracting Authority may determine to be reasonably necessary."
4. **USE OF PREMISES AND REMOVAL OF DEBRIS:** The Contractor expressly undertakes at his own expense:
 - a. to take every precaution against injuries to persons or damage to property;
 - b. to store his apparatus, materials, supplies and equipment in such orderly fashion at the site of the work as will not unduly interfere with the progress of his work or the work of any other contractors;
 - c. to place upon the work or any part thereof only such loads as are consistent with the safety of that portion of the work; materials, and debris caused by his operations, to the end that at all times the site of the work shall present a neat, orderly and workmanlike appearance;
 - d. before final payment to remove all surplus material, false-work, temporary structures, including foundations thereof, plant of any description and debris of every nature resulting from his operations, and to put the site in a neat, orderly condition;
 - e. to effect all cutting, fitting or patching of his work required to make the same to conform to the plans and specifications and, except with the consent of the Public Works Director, not to cut or otherwise alter the work of any other Contractor.
5. **INSURANCE:** The Contractor shall not commence work under this contract until he has obtained all the insurance required by the City of Fairhope (see contract documents) and such insurance has been approved by the Owner, nor shall the Contractor allow any subcontractor to commence work on his subcontract until the insurance required of the subcontractor has been so obtained and approved.
6. **MATERIALS, SERVICES AND FACILITIES:**
 - a. It is understood that except as otherwise specifically stated in the Contract Documents, the Contractor shall provide and pay for all materials, labor, tools, equipment, water, light, power, transportation, supervision, temporary construction of every nature, and all other services and facilities of every nature whatsoever necessary to execute, complete and deliver the work within the specified time.
 - b. Any work necessary to be performed after regular working hours, on Sundays or Legal Holidays, shall be performed without additional expense to the Owner.

7. **CONTRACTOR'S TITLE TO MATERIALS:** No materials or supplies for the work shall be purchased by the Contractor or by any Subcontractor subject to any chattel mortgage or under a conditional sale contract or other agreement by which an interest is retained by the seller. The Contractor warrants that he has good title to all materials and supplies used by him in the work, free from all liens, claims or encumbrances.
8. **INSPECTION AND TESTING OF MATERIALS:**
 - a. All materials and equipment used in the construction of the project shall be subject to adequate inspection and testing in accordance with accepted standards. The laboratory or inspection agency shall be selected by the Owner. The Owner will pay for all laboratory inspection service direct, and not as a part of the contract.
 - b. Materials of construction, particularly those upon which the strength and durability of the structure may depend, shall be subject to inspection and testing to establish conformance with specification and suitability for uses intended.
9. **LIQUIDATED DAMAGES (LD's):** Liquidated Damages (LD's) shall apply. LD's shall be calculated at a fixed rate of \$150.00 per working day beyond the designated contract time.

**ITEM III
BID RESPONSE FORM**

Date: ____ / ____ / ____

Bid No: 24-049 D'Olive Creek Gas Main Replacement

Bids Due: Thursday, June 20, 2024, 10:00 A.M.

BID RESPONSE:

D'Olive Creek Gas Main Replacement Lump Sum Bid (Total Project) \$ _____

Bid will include all labor, materials, equipment, shipping and postage, overhead, profit, bonds, insurance and all other costs necessary to provide the complete services outlined within this CONTRACT and scope of work.

Receipt of the following Addenda to these documents is hereby acknowledged by the undersigned (CONTRACTOR to complete below):

ADDENDUM NO.	DATE ISSUED	ADDENDUM NO.	DATE ISSUED
_____	_____	_____	_____
_____	_____	_____	_____

Each bid must give the full business address of the CONTRACTOR and must be signed by him with his usual signature. Bids by partnerships must furnish the full names of all partners and must be signed with the partnership name by one of the members of the partnership, or by an authorized representative, followed by the signature and designation of the person signing. Bids by corporations must be signed with the legal name of the corporation followed by the name of the State of Incorporation and by the signature and designation of the president, secretary, or other person authorized to bind it in the matter. The name of each person shall also be typed or printed below the signature. A bid by a person who affixes to this signature the word "president," "secretary," "agent," or other designation without disclosing his principal, may be held to be the bid of the individual signing. When requested by the City of Fairhope, Baldwin County, Alabama, satisfactory evidence of the authority of the officer signing in behalf of the corporation shall be furnished.

The undersigned agrees to furnish the goods/services as requested by you for the City of Fairhope, Baldwin County, Alabama in your invitation to bid, and certifies that they will meet or exceed the specifications called for. The undersigned has read all information pertaining to this bid and has resolved all questions. It is also understood and agreed that all prices quoted are F.O.B. described in the bid documents and specifications. The undersigned also affirms he/she has not been in any CONTRACT or collusion among BIDDERS or prospective BIDDERS in restraint of freedom of competition, by CONTRACT to bid at a fixed price or to refrain from bidding or otherwise. Witness our hands and seals this _____ day of _____, 2024.

If Individual or Partnership

(Name of Individual or Partnership)

(Name of Partner Print)

(Name of Representative Authorized to sign Bids and CONTRACTs for the firm Print)

(Name of Partner Print)

Address _____

Phone Number () _____ Fax Number () _____

E-mail address _____ Alabama Contractor's License No. _____

Foreign Entity ID (if outside of Alabama) _____

If Corporation or LLC

Company _____

State of Incorporation _____

Company Representative _____
(Representative Authorized to sign Bids and CONTRACTs for the firm Print)

Company Representative _____
(Representative Authorized to sign Bids and CONTRACTs for the firm Signature)

Address _____

Phone Number () _____ Fax Number(____) _____

E-mail address _____ AL Contractor's License No. _____

Foreign Vendor Id _____

BID PROPOSAL NOTARIZATION:

STATE OF _____ }

COUNTY OF _____ }

I, the undersigned authority in and for said State and County, hereby certify that _____,
as _____ respectively, of _____, whose name is signed to
the foregoing document and who is known to me, acknowledged before me on this day, that, being informed of the contents
of the document they executed the same voluntarily on the day the same bears date.

Given under my hand and Notary Seal on this _____ day of _____, 2024.

NOTARY PUBLIC _____

MY COMMISSION EXPIRES ____/____/____

**ITEM IV
CONTRACTOR INFORMATION**

This Section must be printed, completed, and turned in with your bid response to

**Bid No. 24-049
D'Olive Creek Gas Main Replacement**

Business Organization

Name of CONTRACTOR (exactly as it appears on W-9):

Doing-Business-As Name of CONTRACTOR:

Principal Office Address:

LOCAL Telephone Number: _____ Toll- Free _____

LOCAL Fax Number: _____

Email address: _____

Website: _____

Form of Business Entity [check one ("X")]

Corporation _____

Partnership _____

Individual _____

Joint Venture _____

Other (describe): _____

Corporation Statement

If a corporation, answer the following:

Date of incorporation: _____

Location of incorporation: _____

The corporation is held: Publicly ___

Privately ___

Partnership Statement

If a partnership, answer the following:

Date of organization: _____

Location of organization: _____

The partnership is: General ___

Limited ___

Joint Venture Statement

If a Joint Venture, answer the following:

Date of organization: _____

Location of organization: _____

JV CONTRACT recorded? Yes ___ No ___

Contact: _____ Email _____

Phone _____ Fax _____

END OF CONTRACTOR INFORMATION SECTION

**ITEM V
INSURANCE**

3.0 INSURANCE REQUIREMENTS

Awarded **CONTRACTOR**, at its sole expense, shall obtain and maintain in full force the following insurance to protect the **CONTRACTOR** and the City of Fairhope at limits and coverages specified herein. The City of Fairhope will be listed as an additional insured under the **CONTRACTOR'S** general liability insurance and automobile liability insurance policies, and all other applicable policies and certificates of insurance. These limits and coverages specified are the minimum to be maintained and are not intended to represent the correct insurance needed to fully and adequately protect the awarded **CONTRACTOR**.

3.01 All insurance will be provided by insurers by admitted carriers in the State of Alabama, shall have a minimum A.M. Best rating of A-VII and must be acceptable to the City. Self-insured plans and/or group funds not having an A.M. Best rating must be submitted to the City for prior approval.

3.02 **NO WORK IS TO BE PERFORMED UNTIL PROOF OF COMPLIANCE WITH THE INSURANCE REQUIREMENTS HAS BEEN RECEIVED BY THE CITY.**

3.03 **Worker's Compensation and Employers Liability**

Part One: Statutory Benefits as required by the State of Alabama
Part Two: Employers Liability \$100,000 Each Accident
 \$100,000 Each Employee
 \$500,000 Policy Limit

3.04 **U.S. Longshoreman & Harbor workers Act (USL&H)-**

Required if CONTRACT involves work near a navigable Waterway that may be subject to the USL&H law.

3.05 **Maritime Endorsement (Jones Act)-**

Endorsement required if CONTRACT involves the use of a Vessel. Or include coverage for "Master or Members or Crew" under "Protection and Indemnity" coverage (P&I), unless crew is covered under Workers Compensation.

Bodily injury by accident \$1,000,000 Each Accident
Bodily injury by disease \$1,000,000 Aggregate

3.06 **Commercial General Liability**

Coverage on an Occurrence form with a combined single limit of (Bodily Injury and Property Damage combined as follows:

Each Occurrence	\$1,000,000
Personal and Advertising Injury	\$1,000,000
Products/Completed Operation Aggregate	\$2,000,000
General Aggregate	\$2,000,000

Coverage to include:

- Premises and operations
- Personal Injury and Advertising Injury
- Products/Completed Operations
- Independent BIDDERS
- Blanket Contractual Liability
- Explosion, Collapse and Underground hazards
- Broad Form Property Damage
- Railroad Protective Liability Insurance if work involves construction, demolition or maintenance operations on or within 50 feet of a railroad.

3.07 **Automobile Liability**

Covering all Owned, Non-Owned, and Hired vehicles with a limit of no less than \$1,000,000 combined single limit of Bodily Injury and property damage per occurrence.

3.08 **Certificate of Insurance**

A Certificate of Insurance evidencing the above minimum requirements must be provided to and accepted by the City PRIOR to commencement of any work on the CONTRACT. Each policy shall be endorsed to provide ten (10) days written notice of cancellation to the CITY

Such insurance as is afforded by the above policies covers the operations undertaken by the insured with respect to the construction of the project above designated. The insurance afforded by the above designated policies, specimen copies of which have been filed with the **CITY**, and to each of which is attached for following endorsement.

The insurer agrees with the insured as follows:

1. That it will furnish to said City of Fairhope a certificate of insurance in triplicate on a form approved for such purpose by said **CITY**, setting forth the pertinent information regarding the policy to which this endorsement is attached, for each project of said **CITY** to which the policy applies.
2. That it will attach to each said certificate of insurance executed copies of any endorsement other than this endorsement which are attached to said policy at the time said policy is issued, provided only that said endorsements affect the coverage of said policy in respect of operations involved in the construction of the projects of said **CITY** to which the policy applies.
3. That it will mail to the City Council of the City of Fairhope three executed copies of each endorsement subsequently issued to become a part of said policy provided only that endorsement affects the coverages of said policy in respect of operations involved in the construction of the project of said **CITY** which the policy applies, and provided further that such endorsement shall not be effective unless such notice is given to the **CITY** at the same time that notice thereof is given to the insured.
4. That it will mail to the City Council of the **CITY** of Fairhope at least ten days before the effective date thereof notice of cancellation of said policy, provided no cancellation shall be effective unless such notice is given to the **CITY**.

END OF INSURANCE REQUIREMENTS

ITEM VI



City of Fairhope
CONTRACT

This **CONTRACT** is made this _____ day of _____, 202__, by and between the City of Fairhope (hereinafter referred to as the "**OWNER**") and _____ (hereinafter referred to as the "**CONTRACTOR**"), for

Bid Number/Name

The **OWNER** and the **CONTRACTOR** agree as set forth below:

1. The **CONTRACT** consists of all the items contained within this **CONTRACT**, The Proposal Package, Proposal, Scope of Work and Specifications, drawings (if applicable), Addenda, Amendments, and City of Fairhope Standard Terms and Conditions, which are attached hereto and made a part hereof, as if fully contained herein; for the performance of all work and the furnishing of all labor and materials required for completion of the **WORK**.
2. The **CONTRACTOR** shall perform all the **WORK** described herein.
3. The **WORK** to be performed under this **CONTRACT** shall be commenced upon execution of this **CONTRACT** within number (DAYS) days of the date specified in the *Notice to Proceed* (NTP) to be issued to the **CONTRACTOR** by the **OWNER**, or its authorized representative. The work shall be completed, subject to authorized adjustments, within (DAYS) consecutive calendar days from and after the commencement date stipulated in said *Notice to Proceed*. Liquidated damages for non-completion of the work within this time limit will be assessed at the rate of (DOLLARS) per working day.
4. The **OWNER** shall pay the **CONTRACTOR** in current funds for the performance of the **WORK**, the **CONTRACT SUM** of _____ DOLLARS (\$ _____). This represents a **LUMP SUM** payment for performance of the **WORK**, which payment shall be issued after the Contract is fully performed and the **OWNER** has inspected the **WORK**.
5. **General Conditions**
 - a. **Indemnity:** The **CONTRACTOR** hereby agrees to indemnify and save harmless the **OWNER**, its officers, agent, and employees, from and against any and all liabilities, claims, demands, damages, fines, fees, expenses, penalties, suits, proceedings, actions and cost of actions, including reasonable attorneys' fees for trial and on appeal, of any kind and nature, arising or growing out of, or in any way connected with the performance of this **CONTRACT**, to the extent caused by a negligent act or omission of the **CONTRACTOR**, their agents, servants, employees, **SUB-CONTRACTORS**, or others associated with the **CONTRACTOR**. The **CONTRACTOR** shall be responsible for damage to any elevator equipment excluded from this agreement, or damage or injury caused by any equipment excluded from this agreement, to the extent that the damage or injury is caused by a negligent act or omission of the **CONTRACTOR**.
 - b. **Notification and Accident Reports:** In the event of accidents of any kind, the **CONTRACTOR** shall notify the **OWNER** immediately and furnish, without delay, copies of all such accident reports to the **OWNER**. If in the performance of their Work, the **CONTRACTOR** fails to immediately report an accident to the **OWNER**, of which the **CONTRACTOR** has knowledge of and which results in a fine

levied against the **OWNER** then the **CONTRACTOR** shall be responsible for all fines levied against the **OWNER**.

6. Termination of Agreement

- a. Termination for Default: Performance of Work under this Agreement may be terminated by the **OWNER**, in whole or in part, in writing, whenever the **OWNER** determines that the **CONTRACTOR** has failed to meet the requirements of this Agreement.
 - i. The Owner has a right to terminate for default if the contractor fails to make delivery of material or does not perform the work, or if the Contractor fails to perform the Work within the time specified in the Agreement, or if the Contractor fails to perform any other provision of the Agreement.
 - ii. Failure on the part of the Contractor to deliver or perform the Work within the time specified, or within a reasonable time as determined by the Owner, or failure on the part of the Contractor to make replacements of rejected articles, or Work when so requested, immediately or as directed by the Owner, shall constitute authority for the Owner to purchase in the open market, articles or Work of comparable grade to replace the articles or Work rejected, not delivered or completed. On all such purchases, the Contractor shall reimburse the Owner within a reasonable time specified by the Owner for any expense incurred in excess of Agreement prices.
 - iii. Such purchases shall be deducted from the Agreement sum. If public necessity demands it, the Owner reserves the right to utilize services or use and/or consume articles delivered, which are standard in quality, subject to an adjustment of price to be determined by the Owner.
- b. Termination for Convenience: The **OWNER** has the absolute right to terminate the Agreement upon "Award of Contract" another **CONTRACTOR**, to perform work referenced herein. In such event, payment of the monthly contract fee shall cease on the date of cancellation of the **CONTRACT** by the **OWNER**.

7. Warranty

- a. The **CONTRACTOR** warrants that the Work including equipment and materials provided shall conform to the professional standards of care and practice in effect at the time the Work is performed, be of the highest quality, and be free from all faults, defects, or errors. If the **CONTRACTOR** is notified in writing of a fault, deficiency or error in the Work, the **CONTRACTOR** shall at the **OWNER**'s option, either re-perform such portions of the Work to correct such fault, defect, or error, at no additional cost to the **OWNER**, or refund to the **OWNER** the charge paid by the **OWNER**, which is attributable to such portions of the faulty, defective or erroneous Work, including costs for re-performance or Work provided by other **CONTRACTORS**. All equipment and materials provided by the **CONTRACTOR** shall be merchantable and for the purpose intended and meet all industry quality standards.

8. Time of Completion

The **OWNER** and **CONTRACTOR** understand and agree that time is of the essence in the performance of this Agreement. The **CONTRACTOR** or **OWNER**, respectively, shall not be liable for any loss or damage, resulting from any delay or failure to perform its contractual obligations within the time specified, due to acts of God, actions or regulations by any governmental entity or representative, strikes, fire, water damage, loss of power, loss of funding or any other causes, contingencies, or circumstances not subject to the **OWNER** or **CONTRACTOR**'S control, respectively, whether of a similar or dissimilar nature, which prevent or hinder the performance of the **OWNER**'S or **CONTRACTOR**'S contractual obligations, respectively. Any such causes of delay, even though existing on the date of the **CONTRACT**, or on the day

of the start of Work, shall extend the time of the OWNER'S or CONTRACTOR'S performance respectively, by the length of the delays occasioned thereby, including delays reasonably incident to the resumption of normal Work schedules.

However, under such circumstances as described herein, the OWNER may, at their discretion, cancel this CONTRACT for their own convenience.

9. Insurance Requirements

See **ATTACHMENT B**

10. Acceptance of Work

The OWNER will be deemed to have accepted the Work after the OWNER agrees the Work is completed. In the event Work furnished under the CONTRACT is found to be defective or does not conform to the intent of the CONTRACT, the CONTRACTOR shall, within ten (10) days from receipt of notice from the OWNER, correct the deficiencies. Failure on the part of the CONTRACTOR to properly correct the deficiencies within the time period allowed will constitute the OWNER'S right to cancel the CONTRACT immediately, upon written notice to the CONTRACTOR.

11. Correction of Work

The CONTRACTOR shall promptly correct all Work rejected by the OWNER as faulty, defective or failing to conform to the CONTRACT, whether observed before or after completion of the Work. The CONTRACTOR shall bear all costs of correcting such rejected Work.

12. Right to Audit

The CONTRACTOR shall maintain documentation of all work performed. The CONTRACTOR shall make any and all documentation available to the OWNER at all reasonable times, for inspections and audit by the OWNER, during the entire term of the CONTRACT, and for a period of three (3) years after the expiration of this CONTRACT.

13. CONTRACT Rights and Remedies

The CONTRACTOR shall maintain documentation of all work performed. The CONTRACTOR shall make any and all documentation available to the OWNER at all reasonable times, for inspections and audit by the OWNER, during the entire term of the CONTRACT, and for a period of three (3) years after the expiration of this CONTRACT.

14. Time is of the Essence

The Owner and CONTRACTOR agree that time is of the essence in the performance of Work called for under this CONTRACT. The CONTRACTOR agrees that all work will be accomplished regularly, diligently and uninterrupted at such a rate of progress as will ensure full completion thereof within reasonable time periods.

15. Safety Measures

The CONTRACTOR shall take all necessary precautions for the safety of the OWNER'S and CONTRACTOR'S employees at the Work site, and shall erect and properly maintain at all times, all necessary safeguards for the protection of the workmen and the public. The CONTRACTOR shall post signs warning against hazards in and around the Work site.

16. Extra Work and Associated Costs

- a. Changes in the Work: The OWNER, without invalidating the CONTRACT, may order changes in the Work within the general scope of this CONTRACT, consisting of additions, deletions, or other revision, the CONTRACT price and time for execution of the Work being adjusted accordingly.
- b. All such changes in the Work shall be authorized by a written Amendment to the CONTRACT or a separate Change Order and shall be executed under the applicable conditions of the CONTRACT.

17. Familiarity with the Work

The CONTRACTOR, by executing this CONTRACT, acknowledges full understanding of the extent and character of the Work required and the conditions surrounding the performance thereof. The OWNER will not be responsible for any alleged misunderstanding of conditions surrounding the performance thereof. It is understood that execution of the CONTRACT by the CONTRACTOR serves as his stated commitment to fulfill all requirements and conditions referred to in this CONTRACT.

18. Scope of Work

See **ATTACHMENT B**

19. Contractor Liability

Nothing in this CONTRACT shall be construed to mean that the CONTRACTOR assumes any liability for damages or otherwise, on account of accidents to persons or property, except those resulting from negligence on the part of the CONTRACTOR or its agents, servants, employees, and subcontractors.

20. Miscellaneous Provisions

- a. The CONTRACTOR shall not employ SUB-CONTRACTORS without the express written permission of the OWNER.
- b. The CONTRACTOR shall not assign the CONTRACT or sublet it as a whole without the express written permission of the OWNER. The OWNER may assign the CONTRACT, or sublet it as a whole, without the consent of the CONTRACTOR.
- c. No waiver, alteration, consent, or modification of any of the provisions of the CONTRACT shall be binding unless in writing and signed by the OWNER and CONTRACTOR.
- d. The CONTRACTOR is to procure all permits, licenses, and certificates, or any approvals of plans or specifications as may be required by Federal, State, Local Laws, ordinances, rules, and regulations, for the proper execution and completion of Work covered under this CONTRACT.
- e. The CONTRACTOR shall at all times keep the Work area free from accumulation of waste materials or rubbish caused by his operations, and promptly remove any such materials to an area designated by the OWNER or remove to a waste site as directed by the OWNER. If the CONTRACTOR fails to clean up the Work site, the OWNER will complete the task and charge the CONTRACTOR for such services.
- f. This CONTRACT is considered a non-exclusive Agreement between the parties.
- g. This CONTRACT is deemed to be under and shall be governed by and construed according to the laws of the State of Alabama.
- h. Any litigation arising out of the CONTRACT shall be heard in the Courts of Baldwin County, Alabama.

- i. This CONTRACT contains all terms and conditions agreed upon by the OWNER and CONTRACTOR. No other agreement, oral or otherwise, regarding the subject matter of this CONTRACT shall be deemed to exist or to bind either party hereto.
- j. This CONTRACT shall not be construed against the party or parties preparing it. It shall be construed as if all the parties and each of them jointly prepared this CONTRACT, and any uncertainty or ambiguity shall not be interpreted against one or more parties.

Section 41-16-5, Code of Alabama 1975, requires that public contracts over \$15,000 include the following language:

**By signing this Contract, _____ represents and agrees

 COMPANY NAME
 that it is not currently engaged in, nor will it engage in, any boycott of a person or entity based in or doing
 business with a jurisdiction with which the State of Alabama can enjoy open trade**

IN WITNESS WHEREFORE, the parties hereto have executed this **CONTRACT** as of the day and year first above written.

THE CITY OF FAIRHOPE, ALABAMA

Sherry Sullivan, Mayor

ATTEST:

Lisa A. Hanks, MMC, City Clerk

NOTARY FOR OWNER (CITY OF FAIRHOPE)

STATE OF ALABAMA _____ }
 COUNTY OF BALDWIN _____ }

I, the undersigned authority in and for said State and County, hereby certify that SHERRY SULLIVAN, Mayor of the City of Fairhope whose name is signed to the foregoing document and who is known to me, acknowledged before me on this day, that, being informed of the contents of the document she executed the same voluntarily on the date the same bears date.

Given under my hand and Notary Seal on this _____ day of _____, 202__.

NOTARY PUBLIC _____

MY COMMISSION EXPIRES _____

IF INDIVIDUAL OR PARTNERSHIP

Individual or Partnership

Print Name of Partner

Print Name of Representative Authorized to Sign
Contracts for the firm

Print Name of Partner

Signature of Representative Authorized to Sign
Contracts for the firm

Print Name of Partner

Address

Address

City, State, Zip Code

Phone Number

Fax Number

Primary E-mail Address

AL General Contractor License No. (Attach Copy)

AL General Contractor License Major Categories

AL General Contractor Specialties

AL Foreign Corporation Entity ID (Required of Out of State Vendors)

IF CORPORATION OR LLC

Company

State of Incorporation

Company Representative

Print Name of Representative Authorized to Sign
Contracts for the firm

Signature of Representative Authorized to Sign
Contracts for the firm

Address

Address

City, State, Zip Code

Phone Number

Fax Number

Primary E-mail Address

AL General Contractor License No. (Attach Copy)

AL General Contractor License Major Categories

AL General Contractor Specialties

AL Foreign Corporation Entity ID (Required of Out of State Vendors)

NOTARY FOR INDIVIDUAL, PARTNERSHIP, CORPORATION, OR LLC

STATE OF _____ }
COUNTY OF _____ }

I, the undersigned authority in and for said State and County, hereby certify that _____ As
Name

_____ respectively of _____
Title Company Name

Whose name is signed in the foregoing document and who is known to me, acknowledged before me on this day, being informed of the contents of the document they executed the same voluntarily on the day the same bears date.

Given under my hand and Notary Seal on this _____ day of _____, 202__.

NOTARY PUBLIC _____

MY COMMISSION EXPIRES _____



ITEM VII

CITY OF FAIRHOPE

STANDARD TERMS AND CONDITIONS

1. ACCEPTANCE OF AGREEMENT

This Agreement contains all terms and conditions agreed upon by the Owner and Winning bidder. No other agreement, oral or otherwise, regarding the subject matter of this Agreement shall be deemed to exist or to bind either party hereto. The Winning Bidder shall not employ Subcontractors without the express written permission of the Owner. No waiver, alteration, consent or modification of any of the provisions of the Agreement shall be binding unless in writing and signed by the Owner and Contractor. This Agreement shall not be construed against the party or parties preparing it. It shall be construed as if all the parties and each of them jointly prepared this Agreement, and any uncertainty or ambiguity shall not be interpreted against one or more parties.

2. ACCEPTANCE OF WORK

The City of Fairhope will be deemed to have accepted the Work after the City of Fairhope agrees the Work is completed by signature on delivery or service tickets. In the event Work furnished under the Contract / Agreement / Purchase Order is found to be defective or does not conform to the intent of the Contract / Agreement / Purchase Order, the awarded vendor shall, after receipt of notice from the City of Fairhope, correct the deficiencies. Failure on the part of the awarded vendor to properly correct the deficiencies within the time period allowed will constitute the City of Fairhope's right to cancel the Contract / Agreement / Purchase Order immediately, upon written notice to the awarded vendor.

3. ADDENDA

All Addenda are part of the Contract Documents. Include resultant costs in the Bid. Addenda will be issued by email to all Bidders on record and posted to the City of Fairhope website www.FairhopeAL.gov. It is the responsibility of the bidder to verify that all addenda have been received, and to include all signed addenda in the bid submission

4. ADDITIONAL ORDERS

Unless it is specifically stated to the contrary in the bid response, the City of Fairhope reserves the option to place additional orders against a contract awarded as a result of this solicitation at the same terms and conditions; to extend the renewal date until a new bid is in place, if it is mutually agreeable.

5. APPLICABLE LAW

This Agreement is deemed to be under and shall be governed by and construed according to the laws of the State of Alabama. Any litigation arising out of the Agreement shall be heard in the Courts of Baldwin County, Alabama.

6. ASSIGNMENT

The awarded vendor shall not assign the Contract / Agreement / Purchase Order or sublet it as a whole without the express written permission of the City of Fairhope. The awarded vendor shall not assign any payment due them hereunder, without the express written permission of City of Fairhope. The City of Fairhope may assign the Contract / Agreement / Purchase Order, or sublet it as a whole, without the consent of the awarded vendor.

7. ASSURANCE OF NON-CONVICTION OF BRIBERY

The bidder hereby declares and affirms that, to its best knowledge, none of its officers, directors, or partners and none of its employees directly involved in obtaining contracts has been convicted of bribery, attempted bribery, or conspiracy to bribe under the laws of any state or Federal government.

8. AWARD CONSIDERATION

The following factors will be considered in determining the lowest **responsible** bidder: Overall quality, Conformity with specifications both general and specific, Purposes for which materials or services are required, Delivery dates and time required for delivery, Unit acquisition cost, financial ability to meet the contract, previous performance, facilities and equipment, availability of repair parts, experience, delivery promise, terms of payments, compatibility as required, other costs, and other objective and accountable factors which are reasonable.

9. AWARD OR REJECTION OF BIDS

The Bid will be awarded to the lowest responsible bidder complying with conditions of the invitation for bids, provided his bid is reasonable and it is in the interest of the City of Fairhope to accept it. The bidder to whom the award is made will be notified at the earliest possible date. The City of Fairhope, however, reserves the right to reject any and all bids and to waive any informality in bids received whenever such rejection or waiver is in the interest to the City of Fairhope.

10. BACK ORDERS

If it is necessary to back order any items, the vendor must notify the Purchasing Department and advise as to the expected shipping or delivery date. If this date is not acceptable, the City of Fairhope may seek remedies for default.

11. BID AND PERFORMANCE SECURITY

If bid security is required, a bid bond or cashier's check in the amount indicated on the bid cover must accompany the bid and be made payable to The City of Fairhope of Baldwin County, AL. Corporate or certified checks are not acceptable. Bonds must be in a form satisfactory to the City and underwritten by a company licensed to issue bonds in the State of Alabama. If bid security fails to accompany the bid, it shall be deemed unresponsive, unless the Purchasing Manager deems the failure to be non-substantial. All checks will be returned to the bidders after the contract has been approved. If a performance bond is required, the successful bidder will be notified after the awarding of the contract.

12. BRAND NAMES

Reference to brand names and numbers is descriptive, but not restrictive, unless otherwise specified. Bids on equivalent items meeting the standards of quality thereby indicated will be considered, providing the bid clearly describes the article offered and indicates how it differs from the referenced brands. Descriptive literature or manufacturers specifications plus any supplemental information necessary for comparison purposes should be submitted with the bid or the bid on that item may be rejected. Reference to literature submitted with a previous bid or on file with the Division of Purchasing will not satisfy this requirement. The burden is on the bidder to demonstrate that the item bid is equivalent to the item specified in the ITB. Bids without sufficient documentation to fully support equality, may be considered non-responsive. Reference by the City of Fairhope in the ITB to available existing specifications shall be sufficient to make the terms of such specifications binding on the bidder. Unless the bidder specifies otherwise in its bid, it is understood the bidder is offering a referenced brand item as specified in the ITB or is bidding as specified when no brand is referenced. Failure to examine drawings, specifications and instructions will be at the bidder's risk.

13. BUSINESS LICENSE

The vendor selected to enter into a Contract / Agreement with the City of Fairhope must be licensed to do business in the City of Fairhope prior to commencement of any work under the contract. Delivery of goods or services to the City of Fairhope by Purchase Order have detailed and varied Business License requirements. In all instances that require a business license. Awarded vendor will provide proof of possessing a current City of Fairhope Business License. Prospective bidders will not be required to possess a City of Fairhope Business License prior to award.

14. CANCELLATION OF / CONTRACT / AGREEMENT / PURCHASE ORDER / LEASE

A purchase order can be canceled in whole or in part when awarded vendor fails to deliver or perform as specified. Cancellation of a purchase order can only be made by a written purchase order change (POC) from the City of Fairhope. A term contract, lease or agreement can be canceled by the City of Fairhope, for justifiable cause, or convenience, by written notice.

15. CERTIFICATION PURSUANT TO ACT NO. 2006-557

Alabama law (section 41-4-116, code of Alabama 1975) provides that every bid submitted and contract executed shall contain a certification that the vendor, contractor, and all of its affiliates that make sales for delivery into Alabama or leases for use in Alabama are registered, collecting, and remitting Alabama state and local sales, use, and/or lease tax on all taxable sales and leases into Alabama. By submitting this bid, the bidder is hereby certifying that they are in full compliance with act no. 2006-557, they are not barred from bidding or entering into a contract pursuant to 41-4-116, and acknowledges that the awarding authority may declare the contract void if the certification is false. All corporations must register to do business in Alabama with the Office of the Secretary of State. Their address is:

Office of the Secretary of State

P.O. Box 5616

Montgomery, AL 36103

(334) 242-5324

Fax: (334) 240-3138

<http://www.sos.state.al.us/index.aspx>

The Foreign Corporation form is online at <http://www.sos.state.al.us/downloads/dl1.cfm>.

16. COST OF REMEDYING DEFECTS

All defects, indirect and consequential costs of correcting, removing, or replacing any or all of the defective materials or equipment will be charged against the awarded vendor.

17. DELIVERY OF BID

Bids must be received in the Purchasing Office by the date and time specified on the bid cover. All bids will be accepted until the time and date stated on the bid cover. No bids will be accepted that extend past the time and date on the bid cover. The time of receipt shall be determined by the time clock stamp in the Purchasing Department. Bids submitted by U.S. Mail must be received by the City of Fairhope of Baldwin County, Alabama, in the City of Fairhope offices, 555 South Section St., Fairhope, Al., unless otherwise specified.

18. DELIVERY

The number of calendar days required for delivery after receipt of a purchase order shall be stated in the RFQ / ITB / RFP and /or Purchase Orders. When no time is stated in the document, the time shall be fourteen (14) calendar days after receipt of order. If a shipment is not made within the time period specified, the Purchase Order may be canceled.

19. ENVIRONMENTAL REQUIREMENTS

All products will be clearly labeled for their intended use. Each delivery of product or materials will include a Material Safety Data Sheet (MSDS) for all materials that require an MSDS. All manufacturers/distributors of hazardous substances, including any of the items listed on this bid/quote/ contract and subsequent award must include completed material safety data sheet (MSDS) for each hazardous material. Additionally, each container of hazardous materials must be appropriately labeled with:

- a) The identity of the hazardous material,
- b) Appropriate hazard warnings, and manufacturer, importer, or other responsible party.

20. EQUIPMENT DEMONSTRATION

The City of Fairhope may require equipment/ product materials or service techniques to be demonstrated at a time, date, and location to be specified by the City of Fairhope.

21. EQUIPMENT ELECTRICAL CERTIFICATION

All electrical equipment purchased shall conform to, and be identified in, the applicable standard(s), or otherwise be certified as applicable, as of the bid opening date and time, by Underwriters Laboratories, Inc., or other recognized laboratory facility. Bidder must provide satisfactory documentation with returned bid that all such equipment meets the applicable product standard or has otherwise been certified as outlined above. Unless indicated in the bid document, the above certification shall apply to the equipment itself, not the individual components of that equipment.

22. ERRORS IN BID

Bidders are assumed to be informed regarding conditions, requirements, and specifications prior to submitting bids. Failure to do so will be at the bidder's risk. Bids already submitted may be withdrawn without penalty prior to bid opening. Errors discovered after the bid opening may not be corrected.

23. FORCE MAJEURE

Neither the City nor the awarded vendor shall be deemed in breach of any contract / Purchase Order or Agreement which may result from this proposal submission if it is prevented from performing any of the obligations hereunder by reason of Acts of God, acts of the public enemy, acts of superior governmental authority, strikes or labor disputes, floods, riots, rebellion, sabotage, or any similar other unforeseeable causes beyond its control and not due to its fault or negligence. Each party shall notify the other immediately in writing of the cause of such after the beginning period thereof. The awarded vendor may request cancellation and the City of Fairhope may grant the request if performance is prevented by any of the above referenced causes, or other unavoidable circumstances not attributable to the fault or negligence of the vendor. The burden of proof for such relief rests with the vendor. All correspondence pertaining to cancellation of a purchase order or term contract must be addressed to the City of Fairhope Purchasing Manager.

24. HAZARDOUS AND TOXIC SUBSTANCES

Bidder must comply with all applicable Federal, State, County and City laws, ordinances and regulations relating to hazardous and toxic substances, including such laws, ordinances and regulations pertaining to information hazardous and toxic substances, and as amended from time to time. Bidder shall provide the City of Fairhope with a "Material Safety Data Sheet" for all goods that carry one.

25. INDEMNITY

Indemnity: The awarded vendor hereby agrees to indemnify and save harmless the City of Fairhope, its officers, agent, and employees, from and against any and all liabilities, claims, demands, damages, fines, fees, expenses, penalties, suits, proceedings, actions and cost of actions, including reasonable attorney fees for trial and on appeal, of any kind and nature, arising or growing out of, or in any way connected with the performance of this Contract / Agreement / Purchase Order, to the extent caused by a negligent act or omission of the awarded vendor, their agents, servants, employees, Subcontractors, or others associated with the awarded vendor. The awarded vendor shall be responsible for damage to any equipment excluded from this agreement, or damage or injury caused by any equipment excluded from this agreement, only to the extent that the damage or injury is caused by a negligent act or omission of the awarded vendor or caused by failure of the awarded vendor's supplied product to perform as specified.

26. INSPECTION

All materials, workmanship, equipment, and supplies are subject to inspection and test at any source or time. Final inspection, acceptance or rejection will be made at delivery destination. Goods that do not meet specifications will be rejected unless substitutions have been approved by the City of Fairhope. Failure to inspect or to reject upon receipt, however, does not relieve the awarded vendor of liability. When subsequent tests, after receipt, are conducted and when such tests reveal a failure to meet specifications, the City of Fairhope will reject the goods and the awarded vendor shall immediately supply goods meeting specifications or the City of Fairhope may seek damages including but not limited to the testing expense, regardless of whether a part of or all of the goods have been consumed through the testing process. Rejected goods shall be removed by the awarded vendor promptly after rejection, at his expense. If not removed in fourteen (14) calendar days, they may be disposed of at the discretion of the City of Fairhope. Disposal costs will be the awarded vendor's responsibility.

27. INSPECTION OF PREMISES

At reasonable times, the City may inspect those areas of the awarded vendor's place of business that are related to the performance of a Contract / Agreement / Purchase Order. If the City makes such an inspection, the awarded vendor must provide reasonable assistance. The City of Fairhope reserves the right on demand and without notice all the vendor's files associated with a subsequent Contract / Agreement / Purchase Order where payments are based on the awarded vendor's record of time, salaries, materials, or actual expenses. This same clause will apply to any subcontractors assigned to the Contract / Agreement / Purchase Order.

28. INSURANCE

If a Contract / Agreement / Purchase Order results from this RFQ / ITB / RFP, or other form of solicitation, the awarded vendor shall maintain such insurance as will indemnify and hold harmless the City of Fairhope from Workmen's Compensation and Public Liability claims from property damage and personal injury, including death, which may arise from the awarded vendor's operations under this Contract / Agreement / Purchase Order, or by anyone directly or indirectly employed by him/her.

29. INVITATION TO BID

Any provisions made in the RFQ / ITB / RFP, or other form of solicitation, supersedes any provisions outlined here in the General Terms and Conditions.

30. INVOICING, DELIVERY, PACKAGING

Invoices shall be prepared only after ordered materials have been delivered. All invoices must show the purchase order number. Unless otherwise specified in writing, vendors shall not ship any material without an authorized Purchase Order from the City of Fairhope Purchasing Department. All packages delivered must show the purchase order number. The awarded vendor will be required to furnish all materials, equipment and/or service called for at the bid price quoted. In the event the awarded vendor fails to deliver within a reasonable period of time, as determined by the City of Fairhope, the right is reserved to cancel the award and subsequent purchase order and purchase from the next lowest responsible bidder the items needed. The original awarded vendor will be back charged the difference between the original contract price and the price the City of Fairhope has to pay as a result of the failure to perform by the original awarded vendor. All bids will remain firm for acceptance for 60 days from the date of bid opening. Prices shall be net F.O.B., Prepaid and Allow, City of Fairhope chosen site, Baldwin County, AL. The title and risk of loss of the goods will not pass to the City of Fairhope until receipt and acceptance takes place at the F.O.B. point.

31. LABELING

Individual shipping cartons shall be labeled with the name "City of Fairhope", Purchase Order Number, and where applicable, Contract Number, date of manufacture, batch number, storage requirements, conditions, and recommended shelf life. Bidders are encouraged to offer product packaging with recycled content.

32. LOSS OR DAMAGE IN TRANSIT

Delivery by a vendor to a common carrier does not constitute delivery to the City of Fairhope. Any claim for loss or damage incurred during delivery shall be between the vendor and the carrier. The City of Fairhope accepts title only after satisfactory receipt at the delivery point. The City of Fairhope shall note all visible damages on the freight bill and may refuse the damaged goods. The vendor shall make immediate replacement of the damaged merchandise or be subject to damages for breach of contract. If damage is to a small portion of a total shipment and the City of Fairhope will not be inconvenienced because of the shortage, the vendor may be permitted by the Purchasing Manager to deduct the amount of damage or loss from its invoice, in lieu of replacement. Risk of loss during delivery is borne by the vendor until the goods have been accepted by the City of Fairhope, unless otherwise specified in the RFQ / ITB / RFP or other form of solicitation.

33. MANDATORY SITE VISIT

If the RFQ / ITB / RFP or other form of solicitation requires a mandatory site visit, bidders must inspect the site where installation or service is to take place to obtain a full understanding of scope of work outlined therein. Date of site visit will be determined by the City of Fairhope.

34. MONITORING OF SERVICES

Performance of services will be monitored by the requisitioning department and/or the Purchasing Department, and evaluation reports may be filed with the Purchasing Department. Performance not meeting specifications will result in cancellation of Contract / Agreement / Purchase Order and may result in vendor being removed from the vendor list.

35. NONCONFORMING MERCHANDISE

When merchandise received from the lowest responsible bidder is not in accordance with the purchase order, it will be returned to the bidder, at bidder's expense.

36. NON-DISCRIMINATION

The City of Fairhope is an Equal Opportunity Employer and requires that all contractors comply with the Equal Employment Opportunity laws and the provisions of the Contract / Agreement / Purchase Order documents in this regard. The City also encourages and supports the utilization of Minority Business Enterprises on this and all public bids.

37. NON-EXCLUSIVE

Unless otherwise specified, this Contract / Agreement / Purchase Order is considered a non-exclusive Contract / Agreement / Purchase Order between the parties.

38. NOTIFICATION AND ACCIDENT REPORTS

In the event of accidents of any kind, in the performance of a Contract / Agreement / Purchase Order, the awarded vendor shall notify the City of Fairhope immediately and furnish, without delay, copies of all such accident reports to the City of Fairhope. If in the performance of their Work, the awarded vendor fails to immediately report an accident to the City of Fairhope, of which the awarded vendor has knowledge of and which results in a fine levied against the City of Fairhope then the awarded vendor shall be responsible for all fines levied against the City of Fairhope.

39. PACKAGING

All goods must be packaged in new packing containers. Packing that meets the requirements of common carriers is acceptable, unless otherwise required. A packing slip or invoice must accompany all shipments and must reference the purchase order number. Unless otherwise specified, goods are to be packaged in cartons meeting federal specifications and shipped on non-returnable pallets.

40. PATENTS

Awarded Vendor guarantees that the sale and / or use of goods will not infringe upon any U.S. or foreign patent. Awarded vendor will at his / her own expense, indemnify, protect and save harmless the City of Fairhope, on any patent claims arising from the purchase of goods or services.

41. PAYMENT

Invoices -- Upon completion of service and delivery of materials specified in the applicable Contract / Agreement / Purchase Order, awarded vendor will submit an invoice and signed delivery ticket to:

City of Fairhope
Accounts Payable Department
P.O. Box 429
Fairhope, Al. 36533

All invoices must reference appropriate Purchase Order Numbers Payment of Invoice: All invoices received by the City of Fairhope are payable within thirty (30) days from the date of receipt by the City of Fairhope, provided they are approved by the City of Fairhope.

42. PAYMENT WITHHELD

Payment may be withheld until all items have been delivered and all requirements of the Contract / Agreement / Purchase Order have been fulfilled

43. PRODUCT TESTING

Vendor shall incur all cost involved in obtaining an Independent Laboratory Test if the City deems necessary during the term of the Contract / Agreement / Purchase Order. The City of Fairhope reserves the right to request a demonstration of any and all items bid before making the award.

44. PERMITS LICENSES AND CERTIFICATES

The awarded vendor is to procure all permits, licenses, and certificates, or any approvals of plans or specifications as may be required by Federal, State, Local Laws, ordinances, rules, and regulations, for the proper execution and completion of Work covered under the Contract / Agreement / Purchase Order.

45. PREPARATION OF BID

All bids / proposals shall be typewritten or in ink on the form(s) prepared by the City of Fairhope. Bids / proposals prepared in pencil will not be accepted. All bids / proposals must be signed by officials of the corporation or company duly authorized to sign bids / proposals. Any bid / proposal submitted without being signed will automatically be rejected. All corrections or erasures shall be initialed and dated by the person authorized to sign quotations /bids / proposals. If there are discrepancies between unit prices quoted and extensions, the unit price will prevail.

46. QUESTIONS / CONTACT

Commencing with the issuance of the RFQ / ITB / RFP, or other form of solicitation, no vendor or anyone acting on a vendor's behalf, shall make direct or indirect contact with City personnel or undertake any activities or take any action to otherwise promote its quotation / bid / proposal to the City or its personnel. All communications shall be made to the contact identified in the quotation / bid / proposal documents. Violation of this requirement may, at the City's sole and absolute discretion, be grounds for disqualifying a vendor from further consideration.

47. RECEIPT BY CITY OF FAIRHOPE

If not otherwise stated in the order, the City of Fairhope will be said to have received goods when they have been delivered, unloaded, and placed on the agency's dock or if there is no dock, inside an accessible building, and signed for by an authorized City employee. Shipments will be checked against the receiving copy of the Purchase Order. If the purchase order requires grading certificates, USDA Stamps, or any proof of quality, such proof must accompany the shipment.

48. REJECTION OF BIDS

The City of Fairhope reserves the right to accept or reject any or all bids in whole or in part for any reason, to waive technicalities or informalities, or to advertise for new proposals, if, in the judgment of the awarding authority, the best interest of the City of Fairhope will be promoted thereby. Bidders may be disqualified and rejection of proposals may be recommended for any of (but not limited to) the following causes: Failure to use the bid forms furnished by the City of Fairhope, Lack of signature by an authorized representative on the bid form, Failure to properly complete the bid form and vendor compliance, Evidence of collusion among bidders, Unauthorized alteration of the bid form.

49. RIGHT TO AUDIT

The awarded vendor shall maintain documentation of all work performed. The awarded vendor shall make any and all documentation available to the City of Fairhope at all reasonable times, for inspections and audit by the City of Fairhope for a period of Three (3) years after expiration of the Contract / Agreement / Purchase Order.

50. SAMPLES

Bidders will not be required to furnish samples at the time of bid opening, unless specifically called for. The City of Fairhope reserves the right to request samples after bid opening to assist in the evaluation of proposals submitted.

51. SAFETY MEASURES

The awarded vendor shall take all necessary precautions for the safety of the City of Fairhope's and awarded vendor's employees at the Work site, and shall erect and properly maintain at all times, all necessary safeguards for the protection of the workmen and the public. The awarded vendor shall post signs warning against hazards in and around the Work site.

52. SET-UP AND INSTALLATION

Unless otherwise specified, bid / quotation to include cost of all uncrating, disposal of shipping materials, set-up, testing and initial instruction to agency personnel.

53. SPILL CLEAN UP

The awarded vendor shall be responsible for spillage caused by their negligence, which occurs during transit or unloading operations. The awarded vendor shall immediately report and clean up any spillage. Upon failure to do so, the awarded vendor shall remain responsible for all actual related costs.

54. SUBSTITUTIONS

Substitutions on a purchase order shall require the approval of the Originating Buyer. The City of Fairhope reserves the right to reject at destination and hold at the vendor's risk and expense any goods supplied by the vendor which do not conform to the specification or description embodied in the order or are inferior in any respect to the good specified. Any good bought by sample which is inferior in quality to the sample submitted by vendor will be rejected. Any goods delivered that do not meet specifications may be returned to the vendor at its expense. When a good is returned, the vendor must make immediate replacement with acceptable merchandise, or the City of Fairhope may seek remedies for default.

55. TABULATION

Bid results are posted on The City of Fairhope's web site: www.FairhopeAL.gov. The awarded vendor will be sent a written notification.

56. TAXES

Prices quoted shall be delivered prices, exclusive of all federal or state excise, sales, and manufacturer's taxes. The City will assume no transportation or handling charges other than specified in the RFQ, ITB, RFP or other form of solicitation. The City is tax exempt by law – Code of Alabama 1975.

57. TERMINATION FOR CONVENIENCE

Any Contract / Agreement / Purchase Order may be terminated for convenience by the City of Fairhope, in whole or in part, by written notification to the awarded vendor.

58. TERMINATION FOR DEFAULT

Performance of Work under the Contract / Agreement / Purchase Order Agreement may be terminated by the City of Fairhope, in whole or in part, in writing, whenever the City of Fairhope determines that the awarded vendor has failed to meet the requirements of the Contract / Agreement / Purchase Order.

59. TERMINATION FOR NON-APPROPRIATION

Termination for Non-appropriation – The continuation of any financial obligation beyond the current fiscal year is subject to and contingent upon sufficient funds being appropriated, budgeted, and otherwise made available by the local source, State Legislature and/or federal sources. The City of Fairhope may terminate any financial obligation, and awarded vendor waives any and all claim(s) for damages, effective immediately upon receipt of written notice (or any date specified therein) if for any reason the City of Fairhope's funding from local, State and/or federal sources is not appropriated, withdrawn or limited.

60. TIME IS OF THE ESSENCE

The City of Fairhope and awarded vendor agree that time is of the essence in the performance of work called for under this Contract / Agreement / Purchase Order. The awarded vendor agrees that all work will be accomplished regularly, diligently, and uninterrupted at such a rate of progress as will ensure full completion thereof within reasonable time periods.

61. TITLE

All titles, fees, as well as other charges, are to be paid by awarded vendor. Awarded vendor is to furnish prepaid certificate of title in the name of the City of Fairhope, Title shall change upon acceptance of delivery at the City of Fairhope approved delivery location.

62. VENDOR LIST

A vendor may be removed from the City of Fairhope's Bidders List if a vendor fails to respond to three (3) consecutive ITB's. A properly submitted "No Bid" is considered as a response and the vendor will receive credit for the response.

63. WARRANTY

The awarded vendor expressly warrants that all articles, materials, and work offered shall conform to each and every specification, drawing, sample, or other description which is furnished to or adopted by the City of Fairhope, and that it will be fit and sufficient for the purpose intended, merchantable, of good material and workmanship, and free from defects. The awarded vendor further warrants all items for a period of one year, unless otherwise stated, from the date of acceptance of the items delivered and installed or work completed. All repairs, replacements, or adjustments during the warranty period will be at the awarded vendor's sole expense. Awarded vendor will provide written warranty for all parts and labor for a period of (1) one year commencing from date of written acceptance of delivery by City of Fairhope. Awarded vendor will provide written copies of all other applicable warranties, such as, Manufacturer's warranty. Those warranties, if any, will be in addition to the awarded vendor's warranty, and the terms of which will not be altered by the awarded vendor's warranty.

64. IMMIGRATION LAW

The Contractor agrees that it shall comply with all of the requirements of the **Beason-Hammon Alabama Taxpayer and Citizen Protection Act, Act No 2011-535**, Alabama Code (1975) Section 31-13-1, et. Seq., (also known as the Alabama Immigration Act) see Section 31-13-9, and the provisions of said Act, including all penalties for violation thereof, are incorporated herein.

ITEM VIII

ALABAMA IMMIGRATION ACT CONTRACT REQUIREMENTS

1.0 Background

The **Beason-Hammon Alabama Taxpayer and Citizen Protection Act, Act No 2011-535, as amended by Act No 2012-491, Code of Alabama (1975) Section 31-13-1 through Section 31-13-30** (also known as and hereinafter referred to as “the Alabama Immigration Act”) is applicable to CONTRACTs with the City of Fairhope, Alabama. All business entities entering into CONTRACTs with the City of Fairhope, Alabama will comply with the Alabama Immigration Act.

2.0 Definitions

ALIEN. Any person who is not a citizen or national of the United States, as described in 8 U.S.C. § 1101, et seq., and any amendments thereto.

BUSINESS ENTITY. Any person or group of persons employing one or more persons performing or engaging in any activity, enterprise, profession, or occupation for gain, benefit, advantage, or livelihood, whether for profit or not for profit. Business entity shall include but not be limited to the following:

- a. Self-employed individuals, business entities filling articles of incorporation, partnerships, limited partnerships, limited liability companies, foreign corporations, foreign limited partnerships, foreign liability companies authorized to transact business in this state, business trusts, and any business entity that registers with the Secretary of State.
- b. Any business entity that possesses a business license, permit, certificate, approval, registration, charter, or similar form of authorization issued by the state, any business entity that is exempt by law from obtaining such a business license, an any business entity that is operating unlawfully without a business license.

CONTRACTOR. A person, employer, or business entity that enters into a CONTRACT to perform any service or work or to provide a certain product in exchange for valuable consideration. This definition shall include, but not be limited to, a general CONTRACTOR, SUB-CONTRACTOR, independent CONTRACTOR, CONTRACT employee, project manager, or a recruiting or staffing entity.

EMPLOYEE. Any person directed, allowed, or permitted to perform labor or service of any kind by an employer. The employees of an independent CONTRACTOR working for a business entity shall not be regarded as the employees of the business entity, for the purposes of this chapter. This term does not include any inmate in the legal custody of the state, a county, or a municipality.

EMPLOYER. Any person, firm, corporation, partnership, joint stock association, agent, manager, representative, foreman, or other person having control or custody of any employment, place of employment, or of any employee, including any person or entity employing any person for hire within the State of Alabama, including a public employer. This term shall not include the occupant of a household contracting with another person to perform casual domestic labor within the household.

E-VERIFY. The electronic verification of federal employment authorization program of the Illegal Immigration Reform and Immigrant Responsibility Act of 1996, P.L. 104-208, Division c, Section 403 (a); 8 U.S.C. §1324(a) and operated by the United States Department of Homeland Security, or its successor program.

STATE-FUNDED ENTITY. Any governmental entity of the state or a political subdivision thereof or any other entity that receives any monies from the state or a political subdivision thereof; provided, however, an entity that merely provides a service or a product to any governmental entity of the state or a political subdivision thereof, and receives compensation for the same, shall not be considered a state-funded entity.

SUB-CONTRACTOR. A person, business entity, or employer who is awarded a portion of an existing CONTRACT by a CONTRACTOR, regardless of its tier.

UNAUTHORIZED ALIEN. An alien who is not authorized to work in the United States as defined in 8 U.S.C. § 1324a (h) (3) .

3.0 Mandatory Clause

All CONTRACTS or CONTRACTS to which the state, a political subdivision, or state-funded entity are a party shall include the following clause:

"By signing this CONTRACT, the CONTRACTING parties affirm, for the duration of the CONTRACT, that they will not violate federal immigration law or knowingly employ, hire for employment, or continue to employ an unauthorized alien within the state of Alabama. Furthermore, a CONTRACTING party found to be in violation of this provision shall be deemed in breach of the CONTRACT and shall be responsible for all damages resulting therefrom."

For purposes of this section, "CONTRACT" shall mean a CONTRACT awarded by the state, any political subdivision thereof, or any state-funded entity that was competitively bid or would, if entered into by the state or an agency thereof, be required to be submitted to the CONTRACT Review Permanent Legislative Oversight Committee.

4.0 CONTRACTs Involving Business Entity, or Employer

As a condition for the award of any CONTRACT, grant, or incentive by the state, any political subdivision thereof, or any state-funded entity to a business entity or employer that employs one or more employees, the business entity or employer shall not knowingly employ, hire for employment, or continue to employ an unauthorized alien within the State of Alabama.

As a condition for the award of any CONTRACT, grant, or incentive by the state, any political subdivision thereof, or any state-funded entity to a business entity or employer that employs one or more employees within the state of Alabama, **the business entity or employer shall provide documentation establishing that the business entity or employer is enrolled in the E-Verify program.** During the performance of the CONTRACT, the business entity or employer shall participate in the E-Verify program and shall verify every employee that is required to be verified according to the applicable federal rules and regulations.

5.0 CONTRACTS Involving Subcontracting

Any SUB-CONTRACTOR on a project paid for by CONTRACT, grant, or incentive by the state, any political subdivision thereof, or any state-funded entity shall not knowingly employ, hire for employment, or continue to employ an unauthorized alien within the State of Alabama and shall also enroll in the E-Verify program prior to performing any work on the project. Furthermore, during the performance of the CONTRACT, the SUB-CONTRACTOR shall participate in the E-Verify program and shall verify every employee that is required to be verified according to the applicable federal rules and regulations. This subsection shall only apply to SUB-BIDDERS performing work on a project subject to the provisions of this section and not to collateral persons or business entities hired by the SUB -CONTRACTOR.

6.0 Proof of E-Verify documentation will be in the form of a copy of the signed Memorandum Of Understanding (MOU) generated upon completion of the E-Verify program.

END OF ALABAMA IMMIGRATION ACT CONTRACT REQUIREMENTS

ITEM IX

INVITATION SUMMARY

**Bid No. 24-049
D'Olive Creek Gas Main Replacement**

Bid Name:	BID 24-049 D'Olive Creek Gas Main Replacement
Issue Date:	May 24, 2024
Certificate of Insurance Requirements:	See Item V
Mandatory Pre-Bid Meeting:	Wednesday, June 12, 2024, 10:00 A.M.
Deadline for Questions Date:	Friday, June 14, 2024, 11:00 A.M.
Bid Due Date:	Thursday, June 20, 2024, 10:00 A.M.
City Internet Site:	www.FairhopeAL.gov
SEALED Bid Response Copies to submit:	One (1) Original Paper Copy
Purchasing Department Contact for questions:	Purchasing@FairhopeAL.gov (251) 928-8003

END OF INVITATION SUMMARY

**ITEM X
BID BOND INFORMATION**

Bids shall be accompanied by a Bid Security equal to 5% (percent) of the bid price, but in no event more than \$10,000.00. Bid Security shall be in the form of a Bid Bond or a cashier's check payable to The City of Fairhope. All bonds and/or cashier's check will be made payable to the City of Fairhope for an amount not less than five (5) percent of the City's or its engineers or architects estimated cost of the Project or of the total bid in the proposal, but in no event more than \$10,000.00.

Return of Bid Bonds: All bid bonds, except those of the three lowest bona fide bidders, will be returned immediately after bids have been checked, tabulated and the relation of the bids established. The bid bonds of the three lowest bidders may be retained and if so, will be returned as soon as the contract bonds and the contract documents of the successful bidder have been approved and properly executed.

In the event it is necessary to defer a contract award for longer than fifteen (15) days, after opening of bids, then all bid bonds, except that of the potential successful bidders will be returned.

Award of the contract will be made within the time specified after the opening of bids. In the event no award is made within such time, all bids may be rejected, and all bonds returned.

Provided; however, the potentially successful bidder may enter into a written agreement with the City for an extension of time for consideration of its bid, in which case, the bidder's bond shall remain in full force and effect, or the City may permit said bidder to substitute a satisfactory surety for the cashier's check if submitted as a guaranty to the bid bond.

Forfeiture of Bid Bonds: Should the successful bidder or bidders to whom a contract is awarded fail to execute a contract(s) and furnish acceptable contract securities and evidence of insurance, as required, within thirty (30) days after the prescribed forms have been presented to him/her, the City may retain from the proposal guaranty, if it is a cashier's check or recovered from the principal or the sureties, if the guaranty is a bid bond, the difference between the amount of the contract as awarded, and the amount of the proposals of the new lowest bidder. If no other bids are received, the full amount of the proposal guaranty may be so retained and recovered as liquidated damages for such default. Any sum so retained or recovered shall be the property of the awarding authority.

END OF BID BOND INFORMATION

**ITEM XI
PERFORMANCE BOND**

KNOW ALL MEN: That _____ as Principal,
(name & address of legal title of contractor)

and _____ and
(name & address of legal title of one or more sureties)

(name & address of legal title of one or more sureties)

Hereinafter called the Surety or Sureties, are held and firmly bound unto the CITY OF FAIRHOPE, ALABAMA, hereinafter called the OWNER in the sum of _____ Dollars (\$ _____), for the payment whereof the Principal and the Surety or Sureties bind themselves, their heirs, executors, administrators, successors, and assigns, jointly and severally, firmly by these presents.

WHEREAS, The Principal has, by means of a written agreement, dated ___ / ___ / ___, entered into a contract with the OWNER for **Bid No. 24-049 D'Olive Creek Gas Main Replacement**, which agreement is by reference made a part hereof.

NOW THEREFORE, the conditions of this obligation is such that if the Principal shall faithfully perform the contract on his part, and satisfy all claims and demands, incurred for the same, and shall fully indemnify and save harmless the OWNER from all cost and damage which he may suffer by reason of failure to do so, and shall reimburse and repay OWNER all outlay and expense which the OWNER may incur in making good for any such default thence this obligation shall be null and void: otherwise, it shall remain in full force and effect.

PROVIDED, HOWEVER, that no suit, action or proceedings, by reason of any default whatever be brought on his Bond after twelve months from the day on which the final payment under the Contract falls due.

PROVIDED, further, that the said surety or sureties, for value received hereby stipulate and agree that no change, extension of time, or addition to the terms of the Contract or to the work to be performed thereunder of the specifications thereof shall in any way effect their obligations on this bond, and they do hereby waive notice of any such change, extension of time, alteration or addition to the terms of the contract, or to the work, or to the Specifications.

WITNESS our hands this _____ day of _____, 202____.

IF INDIVIDUAL

_____, Doing Business As, _____
(SIGNATURE of Individual Bidder) (Business Name)

Business Mailing Address _____

IF CORPORATION

(Name of Corporation, Partnership, or Joint Venture)

Business Mailing Address _____

By: _____
(SIGNATURE of officer authorized to sign Bids and Contracts for the company) (Position or Title)

ATTEST:

(Secretary) (Name of State of incorporation)

(Name of Surety) By: _____
(Attorney in Fact)

**ITEM XII
LABOR AND MATERIAL BOND**

KNOWN ALL MEN BY THESE PRESENTS, that we, _____ (hereinafter called the "Contractor") of _____ as principal and (hereinafter called the "Surety"), as Surety, do hereby acknowledge ourselves indebted and firmly bound and held unto the City of Fairhope, Alabama, (hereinafter called the "**City**"), a municipal corporation, existing under and by virtue of the Laws of the State of Alabama, for the use and benefit of those entitled thereto, in the penal sum of _____ (\$_____) for the payment of which well and truly to be made in lawful money of the United States, we do hereby bind ourselves, or successors, assigns and personal representatives, jointly and severally, firmly by these presents.

BUT THE CONDITION OF THE FOREGOING OBLIGATION OR BOND IS THIS:

WHEREAS, the **City** has entered into a certain written contract with said Contractor for **Bid No. 24-049 D'Olive Creek Gas Main Replacement**, in accordance with contract documents heretofore on file in the Office of the **City of Fairhope** at the price of, to-wit: _____ (\$_____) as more fully appears in said written Contract bearing date of _____, 20____, which Contract is hereby referred to and made a part hereof to the same extent as if set out herein in full.

NOW, THEREFORE, if said Principal and all subcontractors to whom any portion of the work provided for in said contract is sublet and all assignees of said Principal and of such subcontractors shall promptly make payment to all persons supplying him or them with labor, foodstuffs, or supplies for or in the prosecution of the work provided for in such contract, or in any amendment or extension of or addition to said contract, and for the payment of reasonable attorney's fees, incurred by the claimant or claimants in suits on said bond, then the above obligation shall be void; otherwise, it shall remain in full force and effect.

PROVIDED, however, that this bond is subject to the following conditions and limitations:

(a) Any person, firm or corporation that has furnished labor, foodstuffs, or supplies for or in the prosecution of the work provided for in said contract, payment for which has not been made, shall have a direct right of action in his or their name or names against the principal and surety on this bond, which right of action shall be asserted in a proceeding, instituted in the county in which the work provided for in said contract is to be performed and in any county in which said Principal or Surety does business. Such right of action shall be asserted in a proceeding instituted in the name of the claimant or claimants for his or their use and benefit against said Principal and Surety or either of them (but not later than one year after the final settlement of said Contract) in which action such claim or claims shall be adjudicated and judgment rendered thereon.

(b) In addition to any other legal mode of service, service of summons and other process in suits on this bond brought in Baldwin County may be had on the Principal or the Surety in accordance with Title 27, Chapter 3, Section 24 of the Ala. Code (1975) by serving a copy of the summons and complaint or other pleading or process, with the Commissioner of Insurance of the State of Alabama or his/ her designee and the Principal and Surety agree to be bound by such mode of service above described and consents that such service shall be the same as personal service on the Principal or Surety.

(c) The Surety shall not be liable hereunder for any damages or compensation recoverable under any workmen's compensation or employer's liability statute.

(d) In no event shall the Surety be liable for a greater sum than the penalty of this bond, or subject to any suit, action or proceeding thereon that is instituted later than one year after the final settlement of said contract.

(e) This bond is given pursuant to the terms of Title 39, Chapter 1, Section 1 of the Ala. Code (1975), and all the provisions of law with reference to this character of bond as set forth in said section or as may hereinafter be enacted are hereby made a part hereof to the same extent as if set out herein in full.

IN WITNESS WHEREOF, the said Contractor has hereunder affixed its signature and said Surety has hereunto caused to be affixed its corporate signature and seal, by its duly authorized officers on the ____ day of _____, 20____.

Principal

By: _____

Title

Surety

ATTEST:

By: _____

Title

ITEM XIII



CITY OF FAIRHOPE CLOSEOUT DOCUMENTS

CONSENT OF SURETY COMPANY TO FINAL PAYMENT

CONTRACTOR'S AFFIDAVIT OF PAYMENT

FINAL RELEASE OF LIENS

NOTICE OF COMPLETION ADVERTISEMENT



**CITY OF FAIRHOPE
CONSENT OF SURETY COMPANY TO FINAL PAYMENT**

COF PROJECT NO: _____

COF PROJECT NAME: _____

OWNER: **City of Fairhope**
P.O. Drawer 429
Fairhope, AL 36533

CONTRACTOR: _____

In accordance with the provision of the Contract between the OWNER and the CONTRACTOR as indicated above, the _____, Surety Company on bond of _____ CONTRACTOR, hereby approved the final payment to the CONTRACTOR and agrees that final payment to the CONTRACTOR shall not relieve the Surety Company of any of its obligations to the City of Fairhope as set forth in said Surety Company's bond dated the _____ day of _____, 202____.

IN WITNESS WHEREOF

The Surety Company has hereunto set its hand this ____ day of _____, 202____.

ATTEST
(Seal)

Surety Company

Signature of Authorized Representative

Title



**CITY OF FAIRHOPE
CONTRACTOR'S AFFIDAVIT OF PAYMENT
OF CLAIMS & DEBTS**

COF PROJECT NO: _____

COF PROJECT NAME: _____

OWNER: **City of Fairhope**
P.O. Drawer 429
Fairhope, AL 36533

CONTRACTOR: _____

STATE OF: _____

COUNTY OF: _____

The undersigned hereby certified that, except as listed below, he has paid in full or otherwise satisfied all obligations for all materials and equipment furnished, for all work, Labor and services performed, and for all known indebtedness and claims against the CONTRACTOR for damages arising in any manner in connection with the performance of the Contract referenced above for which the OWNER or his property might in any way be held responsible.

EXCEPTION: (If none, write NONE) _____

CONTRACTOR

By: _____ **Title:** _____

Subscribed and sworn to and before me this ___ day of _____, 202__.

NOTARY PUBLIC

My Commission expires ___/___/___



**CITY OF FAIRHOPE
FINAL RELEASE OF LIENS**

KNOW ALL MEN BY THESE PRESENTS: In consideration of, and contingent upon the receipt of total payments in the amount of _____

Under and pursuant to the following contract:

COF PROJECT NO: _____

COF PROJECT NAME: _____

The undersigned hereby releases _____, its officers, agents, and employees, of and from all liabilities, obligations, and claims whatsoever in law and in equity under or arising out of said contract. We do hereby certify that all labor, materials, equipment, supplies, etc. for this project have been paid in full and there is no outstanding indebtedness.

IN WITNESS WHEREOF, this release has been executed this _____ day of _____, 202__.

CONTRACTOR

By: SIGNATURE

PRINTED NAME

Title

**STATE OF ALABAMA
COUNTY OF BALDWIN**

I, the undersigned authority, a Notary Public in and for said County and State, hereby certify that _____, whose name is signed to the foregoing instrument and who is known to me, acknowledged before me on this day that, being informed of the contents of the within instrument, he executed the same voluntarily on the day the same bears date.

Given under my hand and seal on this the _____ day of _____, 202__.

NOTARY PUBLIC

My Commission Expires: ___/___/___



**CITY OF FAIRHOPE
NOTICE OF COMPLETION LEGAL NOTICE**

Bid Number: _____

Bid Name: _____

In accordance with Chapter 1, Title 39, Code of Alabama, 1975, for contracts over \$50,000 and less than \$500,000, Notice is hereby given that

_____, CONTRACTOR, has completed the Contract for the above referenced bid for the City of Fairhope, Alabama, OWNER, and has made request for final settlement of said Contract. Any claims for labor, materials or otherwise in connection with this project should be itemized, notarized, and presented to:

OWNER:

**CITY OF FAIRHOPE
555 South Section Street
P.O. Drawer 429
Fairhope, AL 36533**

On or before (30 days) or same will be barred.

Contractor:

Dates ad was run (one time): _____

Newspapers in which ad run (dates): _____

Contractor to provide Proof of Publication of the Notice of Completion to the City by affidavit of the publisher and a printed copy of the notice published.



Future Proposed I-10 Connection

Tie-In

Launch Pit

Gator Alley Boardwalk

6" Steel

N MAIN ST

Exit Pit

Tie-In

Approx. 950' of 6" dual coat steel gas main pipeline.
Boring from the southeast corner of Hwy 98 & Hwy 90 direction south exiting approx. 200' South of D'Olive Creek.

US HIGHWAY 98

N MAIN ST

Cr

D'OLIVE CREEK CROSSING

A.L.D.O.T. PERMIT

GAS LINE INSTALLATION PLANS

CITY OF FAIRHOPE GAS

PERMIT ADDRESS: 29450 N. MAIN ST., DAPHNE, AL 36526

APRIL, 2024

INDEX OF SHEETS

DESCRIPTION	SHEET
COVER SHEET	01
ROUTE MAP	02
PROJECT NOTES	03
TRAFFIC CONTROL PLAN	04-04A
SITE PLAN	05-05B
EROSION CONTROL PLAN	06
DETAILS-TYPICALS	07-07B

BEGINNING MILEPOST: 36.19
ENDING MILEPOST: 36.37

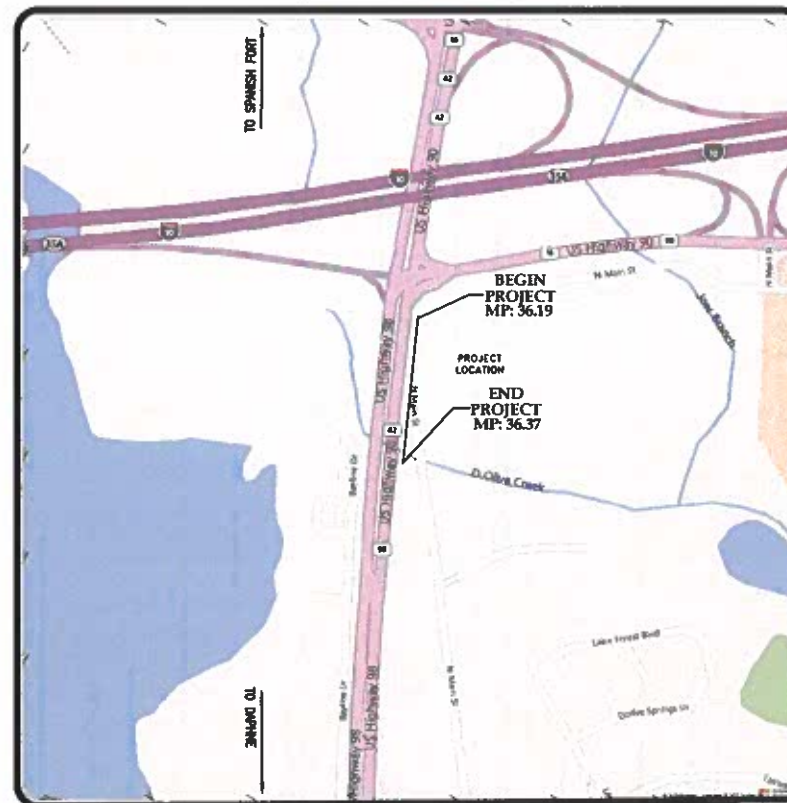

VICINITY MAP

US HWY 98

SPEED
LIMIT
45



ADMINISTRATIVE APPROVAL

AUTHORIZED SIGNATURE

DATE



ENGINEERING - SURVEYING - CONSTRUCTION MANAGEMENT

30673 Sgt. E. I. "Boots" Thomas Drive, Spanish Fort, AL 36527

Phone: (251) 544-7900

ITEM	QUANTITY
6" STEEL GAS MAIN	959 LF
6'X6'X6' BORE PIT	12 LF

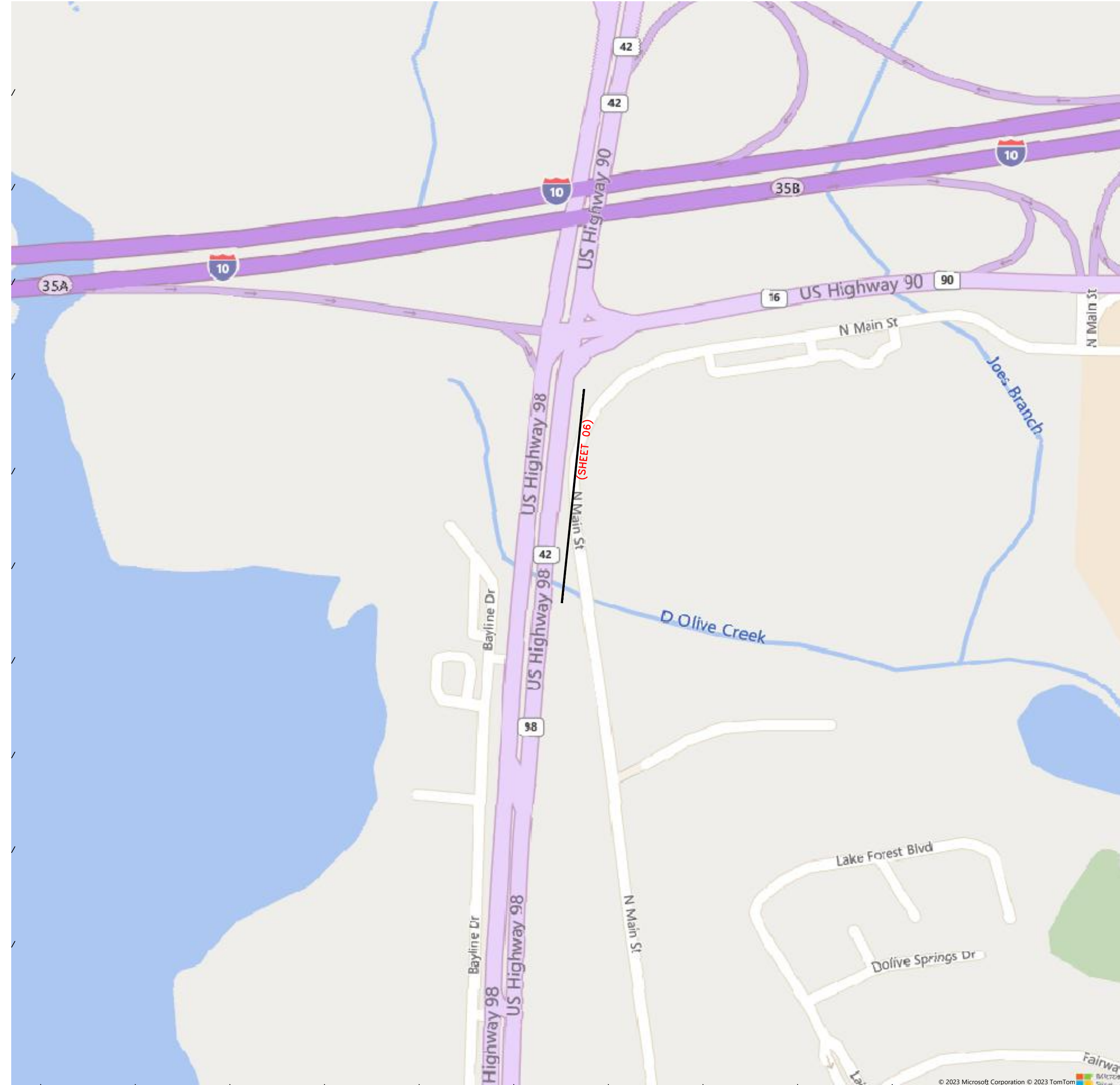

N.T.S.

————— PROPOSED GAS MAIN

NUMBER:	REVISION:	DATE:
01	PER A.L.D.O.T. COMMENTS	4-29-24

ENGINEERING - SURVEYING - CONSTRUCTION MANAGEMENT

30673 Sgt. E. I. "Boots" Thomas Drive, Spanish Fort, AL 36527 Phone: (251) 544-7900

ROUTE
D' OLIVE CREEK
CITY OF FAIRHOPE GAS

SCALE: NTS
DATE: APRIL, 2024
DRAWN BY: KT
CHECKED BY: SD
SHEET: 02 OF 07

ALDOT NOTES:

1. ALL METERS ARE TO BE INSTALLED OFF OF ALDOT RIGHT-OF-WAY.
 2. ALL MANHOLES, VALVE BOXES, AND HAND HOLES SHOULD BE FLUSH WITH EXISTING GROUND.
 3. CONTACT THE DISTRICT ADMINISTRATOR 48 HOURS PRIOR TO BEGINNING WORK ON ALDOT RIGHT-OF-WAY. THE DISTRICT ADMINISTRATORS FOR THE REGION ARE AS FOLLOWS: AREA-9: (91) MOBILE COUNTY- DAVID A. HOLLOWELL (251) 470-8219 - (92) BALDWIN COUNTY-DAVID M. STYRON II, P.E. (251)937-2086 - ESCAMBIA AND CONECUH COUNTIES-MICKEY T. JONES (251)578-7540.
 4. THE ENGINEER OF RECORD SHALL PROMPTLY WRITE AN AS-BUILT CERTIFICATION LETTER TO THE DISTRICT ADMINISTRATOR REQUESTING AN INSPECTION UPON COMPLETION OF THE PERMITTED WORK. ANY PUNCH LIST ITEMS SHALL BE COMPLETED PRIOR TO PROVISIONAL ACCEPTANCE OF WORK.
 5. BONDS SUBMITTED FOR PERMITS SHALL BE HELD FOR A (1) ONE-YEAR MAINTENANCE PERIOD WHICH BEGINS ON THE PROVISIONAL ACCEPTANCE DATE ISSUED BY THE DEPARTMENT. DURING THIS TIME ANY FAILURES, DEFICIENCIES, OR MAINTENANCE CARE SHALL BE THE RESPONSIBILITY OF THE APPLICANT. AT THE END OF THE MAINTENANCE PERIOD THE APPLICANT OR ENGINEER OF RECORD SHALL SUBMIT A BOND RELEASE REQUEST LETTER TO THE DISTRICT ADMINISTRATOR, BONDS ARE NOT RELEASE WITHOUT REQUEST.
 6. ALL TRAFFIC CONTROL SHALL BE IN ACCORDANCE WITH PART 6 OF THE MANUAL ON UNIFORM TRAFFIC CONTROL DEVICES (MUTCD) 2009 EDITION. (IF PROJECT NECESSITATES LANE CLOSURE, LANE CLOSURE MUST BE MADE PART OF THE PERMIT).
- ONSITE REPRESENTATIVES & CONTACT INFORMATION: TAYLOR WESSON, CITY OF FAIRHOPE GAS DEPARTMENT: (251) 597-6844
7. ONSITE REPRESENTATIVES WILL HAVE ON HAND, AT ALL TIMES:
 - (1) APPROVED PERMIT AND PLANS STAMPED BY THE REGION ENGINEER
 - (2) TRAFFIC CONTROL PLANS
 - (3) EROSION CONTROL PLANS
 8. ALL DISTURBED AREAS ON ROW SHALL RECEIVE 4" OF TOPSOIL AND BE SODDED OR SEEDED AS DIRECTED BY THE DEPARTMENT.
 9. ALL WORK ON THE ROW WILL BE IN CONFORMANCE WITH THE LATEST EDITION OF ALDOT STANDARD SPECIFICATIONS.
 10. ELECTRIC POWER AND COMMUNICATION FACILITIES WILL CONFORM TO THE CURRENT APPLICABLE NATIONAL ELECTRICAL SAFETY CODE.
 11. A BEST MANAGEMENT PLAN SHALL AT MINIMUM RETURN ALL EXPOSED AREAS TO ORIGINAL OR BETTER CONDITION AND REQUIRE STAND OF GRASS AND/OR SOD BEFORE ACCEPTANCE. SILT FENCE AND ANY OTHER EROSION CONTROL ITEMS NEEDED SHALL BE USED TO PREVENT EROSION. (NO HAYBALES ARE ALLOWED IN ROW).
 12. ALL TREES OVER 4" DBH SHALL NOT BE CUT/REMOVED WITHOUT WRITTEN PERMISSION FROM ALDOT.
 13. ABSOLUTELY NO BORE PITS SHALL BE ALLOWED TO BE UNFILLED AND/OR UNCOVERED OVERNIGHT UNLESS PROTECTED. (BORE PITS HAVE A MAXIMUM OF 72 HOURS TO BE OPEN BEFORE FILLED).
 14. UPON COMPLETION & ANY TIME THEREAFTER, ALDOT RETAINS THE RIGHT TO REQUEST AN AS-BUILT PLAN OF ANY PERMITTED WORK IN SAID DEPARTMENT'S RIGHTS-OF-WAY.
 15. WARNING: DO NOT DISTURB SURVEY MARKERS LOCATED ON ALDOT RIGHT-OF-WAY. ANY PROPERTY MARKERS DISTURBED DURING CONSTRUCTION SHALL BE RE-ESTABLISHED BY AN ALABAMA LICENSED PROFESSIONAL LAND SURVEYOR AT THE EXPENSE OF THE PERMIT APPLICANT.
 16. THE TOTAL AREA TO BE DISTURBED DURING CONSTRUCTION OF THIS PERMIT: 0.01 ACRE(S). (ON & OFF ROW COMBINED).
 17. WATER LINES SHALL CONFORM TO THE CURRENTLY APPLICABLE STANDARDS OF THE AMERICAN WATER WORKS ASSOCIATION.
 18. PRESSURE PIPE LINES SHALL CONFORM TO THE CURRENTLY APPLICABLE SECTIONS OF AMERICAN NATIONAL STANDARDS INSTITUTE (ANSI).
 19. AS REQUIRED BY ALABAMA ACT 94-487: CALL TWO WORKING DAYS BEFORE EXCAVATION 1-800-292-8525, ALABAMA LINE LOCATION CENTER, INC.
 20. ALL EXISTING UTILITY FACILITIES IN THE PROPOSED WORK AREA SHALL BE PHYSICALLY LOCATED BOTH HORIZONTALLY AND VERTICALLY.
 - A. THE UTILITY FACILITIES IN THE AREA OF WORK ARE REPRESENTED TO THE BEST OF MY KNOWLEDGE, ACCORDING TO LOCATES PROVIDED BY 811 AND INDIVIDUAL DUE DILIGENCE. ENGINEER INITIALS: SD
 - B. 811 LOCATE REQUEST NUMBERS: 230370406
 21. ANY ORNAMENTAL VEGETATIVE LANDSCAPING (SHRUBS, FLOWERS, ORNAMENTAL GRASS, ETC.) DISTURBED DURING CONSTRUCTION SHALL BE REPLACED, TRANSPLANTED OR SODDED BY THE APPLICANT AS DIRECTED BY THE ALABAMA DEPARTMENT OF TRANSPORTATION DISTRICT ADMINISTRATOR.
 22. ALL FILL MATERIAL OR ONSITE DEBRIS DEPOSITED IN THE RIGHT-OF-WAY SHALL BE REMOVED PRIOR TO ISSUANCE OF FINAL ACCEPTANCE TO BEGIN THE ONE YEAR MAINTENANCE PERIOD OF THE PERMIT CONTRACT.
 23. THE APPLICANT SHALL SEE THAT ALL SOLID WASTE (I.E., WOOD, STUMPS, ETC.) IS DISPOSED OF IN ACCORDANCE WITH APPLICABLE REGULATIONS OF THE ALABAMA DEPARTMENT OF ENVIRONMENTAL MANAGEMENT (ADEM).
 24. PROPERTY OBSTRUCTIONS WHICH ARE TO REMAIN IN PLACE, SUCH AS HISTORICAL STRUCTURES, TREES, DRAINS, WATER OR GAS PIPES, POLES, WALL, ETC., ARE NOT TO BE DISTURBED UNLESS NOTED AND APPROVED BY SHPO, ALDOT, ADEM, EPA, ETC.
 26. THE APPLICANT IS RESPONSIBLE TO SEE THAT STREETS ARE CLEANED IMMEDIATELY AFTER CONCRETE OR OTHER DELIVERY TRUCKS LEAVE THE SITE. MUD AND DEBRIS ARE TO BE KEPT OFF STREETS, AND OUT OF INLETS, DITCHES, ETC.
 27. FUEL TANKS SHALL NOT BE STORED ON THE RIGHT-OF-WAY OVERNIGHT. VEHICLES TRANSPORTING FUEL, CHEMICALS, FERTILIZERS, ETC. ONTO RIGHT-OF-WAY SHALL NOT BE LEFT UNATTENDED.
 28. THE APPLICANT OR ENGINEER OF RECORD SHALL PROMPTLY NOTIFY ALDOT OF ANY PERCEIVED CONFLICTS, AMBIGUOUS ITEMS OR DEFICIENCIES IN THE PLANS, SPECIFICATIONS, GENERAL NOTES OR RELATED CONTRACT DOCUMENTS.
 29. FOR WORK WITHIN THE INTERSTATE ROW, ALL INGRESS AND EGRESS TO WORKSITE SHALL BE FROM APPLICANT'S PROPERTY. NO ACCESS SHALL BE GAINED FROM THE INTERSTATE ROW. EQUIPMENT AND MATERIALS SHALL NOT BE STORED ON INTERSTATE ROW.
 30. MILEPOST(S): 36.19, 36.21, AND 36.37 SPEED LIMIT: 45 MPH STOPPING SIGHT DISTANCE: 500 FEET
 31. DRAINAGE FROM THIS SITE WILL NOT BE DIRECTED ONTO STATE R/W. ENGINEER INITIALS: SD
 32. UTILITY CONFLICTS OR UTILITY RELOCATION ARE NOT REQUIRED FOR THIS PROJECT. ENGINEER INITIALS: SD
 33. MINIMUM COVER OVER UTILITIES WILL BE MAINTAINED UPON COMPLETION OF WORK. ENGINEER INITIALS: SD
 34. THE LEGAL PERMIT APPLICANT IS HELD RESPONSIBLE AND LIABLE FOR ALL DAMAGES, ACTIONS, OR RESPONSIBILITIES OF THEIR APPOINTED CONTRACTORS AND APPOINTEES.

MATERIAL SPECIFICATIONS:

6" STEEL GAS MAIN	
DESIGN PRESSURE	220 PSI
MAX OPERATING PRESSURE	190 PSI
OPERATING PRESSURE	190 PSI

DESCRIPTION OF WORK:

1. PROPOSED INSTALLATION OF 959 L.F. OF 6" STEEL GAS MAIN WITHIN THE ALABAMA DEPARTMENT OF TRANSPORTATION MAINTAINED RIGHT-OF-WAY OF HWY.
2. UNDERGROUND GAS WILL BE INSTALLED MIN. 10' DEEP FOR CREEK CROSSING, 48" DEEP FOR ROAD CROSSINGS.
3. ALL BORE PITS/TIE-INS SHALL BE RESTORED USING SOLID SOD (MATCH IN-KIND) PER 6'X6'X6' BORE PITS/TIE-INS.

TRAFFIC CONTROL NOTES:

1. ALL TRAFFIC CONTROL SHALL BE IN ACCORDANCE WITH VI OF THE MANUAL ON UNIFORM TRAFFIC CONTROL DEVICES (M.U.T.C.D.) 2009 EDITION. (SEE ATTACHED PLAN SHEETS 07-07B)
2. THE CONTRACTOR SHALL CONTACT THE CITY OF DAPHNE PUBLIC WORKS.

WILLIAM ERINGMAN, PUBLIC WORKS DIRECTOR (251) 620-2100

MISC. NOTES:

1. ALL BORE PITS, HANDHOLES, AND PROPOSED GAS MAIN SHALL MAINTAIN A MINIMUM OF 36" HORIZONTAL AND/OR VERTICAL CLEARANCE FROM ALL STORM SEWER STRUCTURES.
2. EVERY EFFORT SHALL BE MADE TO PRESERVE THE INTEGRITY OF ALL DRIVEWAYS. DURING INSTALLATION, SHOULD IT BE DEEMED NECESSARY TO DISTURB ANY DRIVEWAYS, THE CONTRACTOR SHALL RESTORE THE DRIVEWAY TO ITS PRE-DISTURBED CONDITION.
3. EVERY EFFORT SHALL BE MADE TO PRESERVE THE INTEGRITY OF ALL SIDEWALKS. DURING INSTALLATION, SHOULD IT BE DEEMED NECESSARY TO DISTURB ANY SIDEWALK, THE CONTRACTOR SHALL REFER TO THE SIDEWALK STANDARDS DRAWING.

SOIL EROSION & SEDIMENT CONTROL NOTES:

1. ALL EROSION AND SEDIMENT CONTROL PRACTICES MUST BE IN ACCORDANCE WITH THE ALABAMA HANDBOOK FOR EROSION CONTROL, SEDIMENT CONTROL AND STORM WATER MANAGEMENT FOR CONSTRUCTION SITES AND URBAN AREAS, VOLUME 1 AND 2, CURRENT EDITION.
2. THE MEASURES SET FORTH IN THE EROSION CONTROL PLAN ARE INTENDED AS THE MINIMUM STANDARDS, ANY EROSION CONTROL MEASURE BEYOND THAT SPECIFIED IN THE PLAN, THAT IS REQUIRED TO COMPLY WITH LOCAL, STATE, AND FEDERAL LAW, SHALL BE IMPLEMENTED.
3. IN THE EVENT THAT EROSION PREVENTION AND CONTROL DEVICES SHOWN IN THE EROSION CONTROL PLAN PROVE NOT TO BE EFFECTIVE, ALTERNATE METHODS FOR MAINTAINING STATE WATER QUALITY STANDARDS FOR DISCHARGE FROM THE CONSTRUCTION SITE WILL BE REQUIRED. ALL ALTERNATE EROSION PREVENTION AND CONTROL DEVICES MUST BE REVIEWED AND APPROVED BY LOCAL AND STATE COMPLIANCE PERSONNEL PRIOR TO PLACEMENT.
4. THE CONTRACTOR SHALL INSPECT INSTALLED BMPS AT LEAST ONCE EVERY SEVEN (7) DAYS AND REPAIR OR REPLACE MY DAMAGED OR INEFFECTIVE DEVICES.
5. THE CONTRACTOR SHALL INSPECT INSTALLED BMPS WITHIN 24 HOURS AFTER PRECIPITATION EVENTS OF 0.50 INCHES OR GREATER AND REPAIR OR REPLACE ANY DAMAGED OR INEFFECTIVE DEVICES.
6. DISTURBED AREAS SHALL BE GRADED, SODDED, OR VEGETATED (SEEDED AND MULCHED)WITHIN 13 DAYS OF ANY CONSTRUCTION ACTIVITY FOR AN EFFECTIVE BMP.
7. ALL AREAS IDENTIFIED TO HAVE SOLID SODDING, SHALL BE VEGETATED WITH PERMANENT SEEDING (SEASONAL MIX) IN ACCORDANCE WITH SECTION 860, TABLE FOR ZONE 3 IN THE ALABAMA DEPARTMENT OF TRANSPORTATION STANDARD SPECIFICATIONS HIGHWAY CONSTRUCTION (CURRENT EDITION).
8. SILT FENCE MUST MEET THE REQUIREMENTS OF LOCAL JURISDICTIONAL AGENCY, SAID REQUIREMENTS AS SHOWN BY THESE PLANS.
9. WHEN ANY CONSTRUCTION BORDERS A DRAINAGE COURSE:
 - A) THE CONTRACTOR IS RESPONSIBLE FOR REMOVING ANY BUILDING OR OTHER EXCAVATION SPOIL DIRT, CONSTRUCTION TRASH OR DEBRIS, ETC., FROM THE DRAINAGE AREA SHOWN HEREON IN AN EXPEDITIOUS MANNER AS CONSTRUCTION PROGRESSES.
 - B) THE CONTRACTOR HEREBY AGREES TO STOP ALL WORK AND RESTORE THESE AREAS IMMEDIATELY UPON NOTIFICATION BY THE LOCAL JURISDICTIONAL INSPECTOR AND/OR PROFESSIONAL ENGINEER.
10. A COPY OF THE APPROVED "PERMIT TO DEVELOP" AND "A.D.E.M. N.O.I." SHALL BE POSTED ON THE SITE AT ALL TIMES DURING CONSTRUCTION AS PART OF CONSTRUCTION BOARD AND SHALL BE VISIBLE TO THE PUBLIC.
11. CONTRACTOR SHALL MAINTAIN ALL EROSION CONTROL MEASURES UNTIL PERMANENT VEGETATION HAS BEEN ESTABLISHED. CONTRACTOR SHALL CLEAN OUT ALL SEDIMENT PONDS WHEN REQUIRED BY THE ENGINEER OR LOCAL JURISDICTIONAL INSPECTOR. CONTRACTOR SHALL INSPECT EROSION CONTROL MEASURES AT THE END OF EACH WORKING DAY TO ENSURE MEASURES ARE FUNCTIONING PROPERLY.
12. ALL SLOPES SHALL BE STABILIZED AND VEGETATED AS SOON AS POSSIBLE. USE EROSION CONTROL BLANKET (ECB) WHERE GRASSING SLOPES ARE INTERMITTENT.
13. ALL CONSTRUCTION WASTE AND DEBRIS, SILT FENCES, HAY BALES, AND INLET PROTECTION AND OTHER TEMPORARY BMP'S HALL BE REMOVED FROM THE SITE UPON CONSTRUCTION COMPLETION.

NUMBER:	REVISION:	DATE:
01	PER A.L.D.O.T. COMMENTS	4-29-24



PROJECT NOTES
D' OLIVE CREEK
CITY OF FAIRHOPE GAS

SCALE: NTS
DATE: APRIL, 2024
DRAWN BY: KT
CHECKED BY: SD
SHEET: 03 OF 07

- TRAFFIC CONTROL PLAN -
SHOULDER WORK WITH OPTIONAL
MINOR ENCROACHMENT
REF TA-6 (MUTCD 2009)

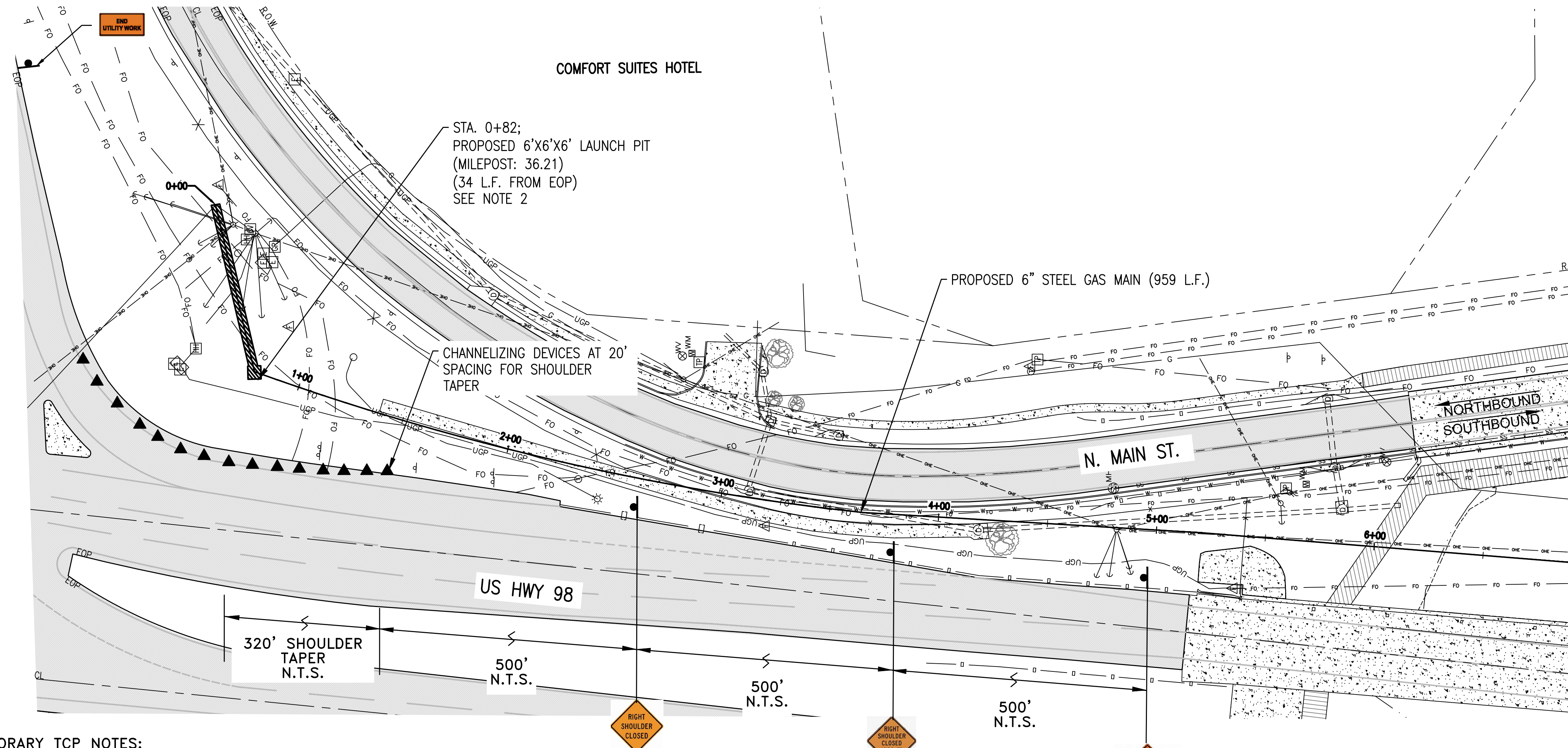

US HWY 98
**SPEED
LIMIT
45**

TEMPORARY TCP NOTES:

- NO TRAFFIC TO BE AFFECTED ALONG US HWY 98.
- OPTIONAL TRAFFIC CONTROL FOR INTERSECTING SIDE ROADS WITHIN THE WORK AREA MAY BE IMPLEMENTED ALONG THIS SEGMENT WHEN/IF NEEDED.
 - IF TRAFFIC IS AFFECTED, CONTRACTOR SHALL CONTACT THE ALDOT DISTRICT 92 ADMINISTRATOR @ 251-937-2086 AND DIRECTOR OF CITY OF DAPHNE @ 251-621-2100 48 HRS PRIOR TO CONSTRUCTION.
 - IN THE EVENT THAT THE USE OF GPR CAUSES TRAFFIC TO BE AFFECTED, THE CONTRACTOR SHALL IMPLEMENT A TRAFFIC CONTROL SCHEME FOR "SHOULDER WORK WITH MINOR ENCROACHMENT" (TA-6). REFER TO CHAPTER 6 OF MUTCD, LATEST EDITION.
 - THE CONTRACTOR WILL NOT INTERRUPT DRIVEWAY ACCESSES OR SIDE STREETS FOR LONG PERIODS OF TIME. THE CONTRACTOR SHALL PROVIDE AVAILABLE PERSONNEL TO REMOVE ANY TCP DEVICES FOR HOME OWNER ACCESS OR THRU WAY TRAFFIC.

Table 6C-1. Recommended Advance Warning Sign Minimum Spacing

Road Type	Distance Between Signs**		
	A	B	C
Urban (low speed)**	100 feet	100 feet	100 feet
Urban (high speed)**	350 feet	350 feet	350 feet
Rural	500 feet	500 feet	500 feet
Expressway / Freeway	1,000 feet	1,500 feet	2,640 feet

NOTE: RECOMMENDED ADVANCE WARNING SIGN MINIMUM SPACING IN ACCORDANCE WITH TABLE 6C-1

LEGEND

- C.R.F. CAPPED REBAR FOUND
- R.B.F. REBAR FOUND
- [E] ELECTRIC METER
- [TR] TRANSFORMER
- [HH] HAND HOLE
- [SMH] SANITARY SEWER MANHOLE
- [TP] TELEPHONE PEDESTAL
- [FH] FIRE HYDRANT
- [WM] WATER METER
- X- EXIST. FENCE
- D- EXIST. GUARDRAIL
- D- EXIST. DITCH
- ⊗^{WV} WATER VALVE
- ⊗^{GV} GAS VALVE
- ⚠ FIBER MARKER
- ⚠ GAS MARKER
- ⊕ DRAINAGE INLET
- OHE- EXIST. OVERHEAD POWER
- UGPL- EXIST. UNDERGROUND POWER
- S- EXIST. SEWER LINE
- W- EXIST. WATER LINE
- G- EXIST. GAS MAIN
- EOP- EDGE OF PAVEMENT
- CL- CENTERLINE
- R.O.W.- RIGHT-OF-WAY

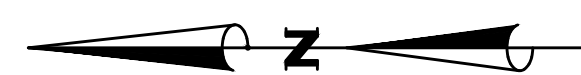

NUMBER:	REVISION:	DATE:
01	PER A.L.D.O.T. COMMENTS	4-29-24

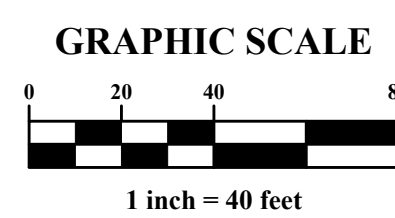

Sawgrass
 ENGINEERING - SURVEYING - CONSTRUCTION MANAGEMENT
30673 Sgt. E. I. "Boots" Thomas Drive, Spanish Fort, AL 36527 Phone: (251) 544-7900

UNDERGROUND UTILITY NOTE:
 UNDERGROUND UTILITY LOCATIONS SHOWN ARE APPROXIMATE AND ARE BASED ON INFORMATION PROVIDED. THE UTILITIES SHOWN MAY NOT BE A COMPLETE REPRESENTATION OF ALL UTILITY LINES IN THE PROJECT AREA. CONTRACTOR IS REQUIRED TO CONTACT ALABAMA ONE CALL PRIOR TO DIGGING (1-800-292-8525) (WWW.AL1CALL.COM). OTHER UTILITIES (INCLUDING PRIVATE UTILITIES OUTSIDE A PUBLIC RIGHT-OF-WAY) THAT DO NOT PARTICIPATE IN THE ALABAMA ONE CALL LINE LOCATION SERVICE NEED TO BE CONTACTED INDIVIDUALLY AND/OR PHYSICALLY LOCATED BY THE CONTRACTOR.

TRAFFIC CONTROL PLAN - WEST
D'OLIVE CREEK
CITY OF FAIRHOPE GAS

SCALE: 1" = 40'
DATE: APRIL, 2024
DRAWN BY: KT
CHECKED BY: SD
SHEET: 04 OF 07

DWG: INFO: 5/11/2024 10:38:13 AM
 CLIENT: 23-177 D'OLIVE CREEK CROSSING CITY FAIRHOPE CIVIL ENGINEERING PRODUCTION: DWG: SITE PLAN: D'OLIVE CREEK 4-29-24.DWG

- TRAFFIC CONTROL PLAN -
SHOULDER WORK WITH OPTIONAL
MINOR ENCROACHMENT
REF TA-6 (MUTCD 2009)

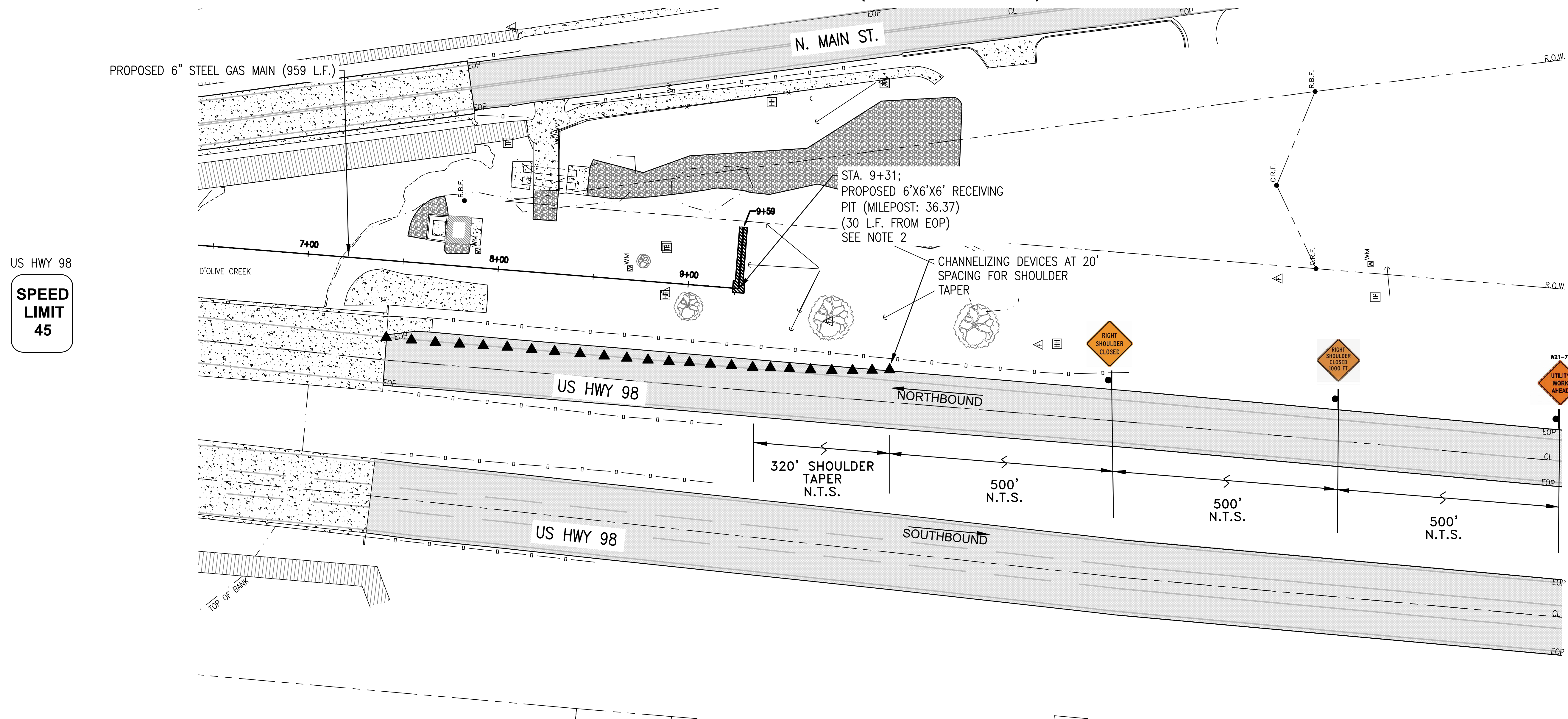

Table 6C-1. Recommended Advance Warning Sign Minimum Spacing

Road Type	Distance Between Signs**		
	A	B	C
Urban (low speed)**	100 feet	100 feet	100 feet
Urban (high speed)**	350 feet	350 feet	350 feet
Rural	500 feet	500 feet	500 feet
Expressway / Freeway	1,000 feet	1,500 feet	2,640 feet

NOTE: RECOMMENDED ADVANCE WARNING SIGN MINIMUM SPACING IN ACCORDANCE WITH TABLE 6C-1

- TEMPORARY TCP NOTES:**
NO TRAFFIC TO BE AFFECTED ALONG US HWY 98.
- OPTIONAL TRAFFIC CONTROL FOR INTERSECTING SIDE ROADS WITHIN THE WORK AREA MAY BE IMPLEMENTED ALONG THIS SEGMENT WHEN/IF NEEDED.
 - IF TRAFFIC IS AFFECTED, CONTRACTOR SHALL CONTACT THE ALDOT DISTRICT 92 ADMINISTRATOR @ 251-937-2086 AND DIRECTOR OF CITY OF DAPHNE @ 251-621-2100 48 HRS PRIOR TO CONSTRUCTION.
 - IN THE EVENT THAT THE USE OF GPR CAUSES TRAFFIC TO BE AFFECTED, THE CONTRACTOR SHALL IMPLEMENT A TRAFFIC CONTROL SCHEME FOR "SHOULDER WORK WITH MINOR ENCROACHMENT" (TA-6). REFER TO CHAPTER 6 OF MUTCD, LATEST EDITION.
 - THE CONTRACTOR WILL NOT INTERRUPT DRIVEWAY ACCESSES OR SIDE STREETS FOR LONG PERIODS OF TIME. THE CONTRACTOR SHALL PROVIDE AVAILABLE PERSONNEL TO REMOVE ANY TCP DEVICES FOR HOME OWNER ACCESS OR THRU WAY TRAFFIC.

LEGEND

- C.R.F. CAPPED REBAR FOUND
- R.B.F. REBAR FOUND
- ⊞ POWER POLE
- ⊞ E ELECTRIC METER
- ⊞ TR TRANSFORMER
- ⊞ HH HAND HOLE
- ⊞ GUY WIRE
- ⊞ MH SANITARY SEWER MANHOLE
- ⊞ TP TELEPHONE PEDESTAL
- ⊞ FH FIRE HYDRANT
- ⊞ WM WATER METER
- ⊞ X EXIST. FENCE
- ⊞ G EXIST. GUARDRAIL
- ⊞ EXIST. DITCH
- ⊞ WV WATER VALVE
- ⊞ GV GAS VALVE
- ⊞ FIBER MARKER
- ⊞ GAS MARKER
- ⊞ DRAINAGE INLET
- OHE — EXIST. OVERHEAD POWER
- UGPL — EXIST. UNDERGROUND POWER
- S — EXIST. SEWER LINE
- W — EXIST. WATER LINE
- G — EXIST. GAS MAIN
- EOP — EDGE OF PAVEMENT
- CL — CENTERLINE
- R.O.W. — RIGHT-OF-WAY

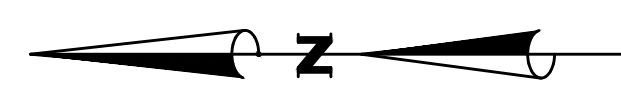

NUMBER:	REVISION:	DATE:
01	PER A.L.D.O.T. COMMENTS	4-29-24

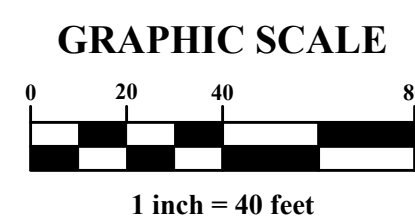

Sawgrass
 ENGINEERING - SURVEYING - CONSTRUCTION MANAGEMENT
30673 Sgt. E. I. "Boots" Thomas Drive, Spanish Fort, AL 36527 Phone: (251) 544-7900

UNDERGROUND UTILITY NOTE:
UNDERGROUND UTILITY LOCATIONS SHOWN ARE APPROXIMATE AND ARE BASED ON INFORMATION PROVIDED. THE UTILITIES SHOWN MAY NOT BE A COMPLETE REPRESENTATION OF ALL UTILITY LINES IN THE PROJECT AREA. CONTRACTOR IS REQUIRED TO CONTACT ALABAMA ONE CALL PRIOR TO DIGGING (1-800-292-8525) (WWW.A1CALL.COM). OTHER UTILITIES (INCLUDING PRIVATE UTILITIES OUTSIDE A PUBLIC RIGHT-OF-WAY) THAT DO NOT PARTICIPATE IN THE ALABAMA ONE CALL LOCATION SERVICE NEED TO BE CONTACTED INDIVIDUALLY AND/OR PHYSICALLY LOCATED BY THE CONTRACTOR.

TRAFFIC CONTROL PLAN - EAST
D' OLIVE CREEK
CITY OF FAIRHOPE GAS

SCALE: 1" = 30'
DATE: APRIL, 2024
DRAWN BY: KT
CHECKED BY: SD
SHEET: 04A OF 07

DWG: INFO: S:\1-CLIENTS\24-177-D'OLIVE CREEK CROSSING CITY FAIRHOPE CIVIL ENGINEERING\PRODUCTION DWGS\SITE PLAN\D'OLIVE CREEK 4-29-24.DWG --4/30/2024 10:38:18 AM

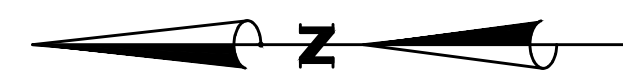

LEGEND

- C.R.F. CAPPED REBAR FOUND
- R.B.F. REBAR FOUND
- E ELECTRIC METER
- TR TRANSFORMER
- HH HAND HOLE
- ← GUY WIRE
- ⊙ SSMH SANITARY SEWER MANHOLE
- ⊙ TP TELEPHONE PEDESTAL
- ⊙ FH FIRE HYDRANT
- ⊙ WM WATER METER
- ⊙ WV WATER VALVE
- ⊙ GV GAS VALVE
- ⊙ FM FIBER MARKER
- ⊙ GM GAS MARKER
- ⊙ DI DRAINAGE INLET
- OHE EXIST. OVERHEAD POWER
- UGPL EXIST. UNDERGROUND POWER
- S EXIST. SEWER LINE
- W EXIST. WATER LINE
- G EXIST. GAS MAIN
- X EXIST. FENCE
- □ EXIST. GUARDRAIL
- ··· EXIST. DITCH
- EOP EDGE OF PAVEMENT
- CL CENTERLINE
- R.O.W. RIGHT-OF-WAY

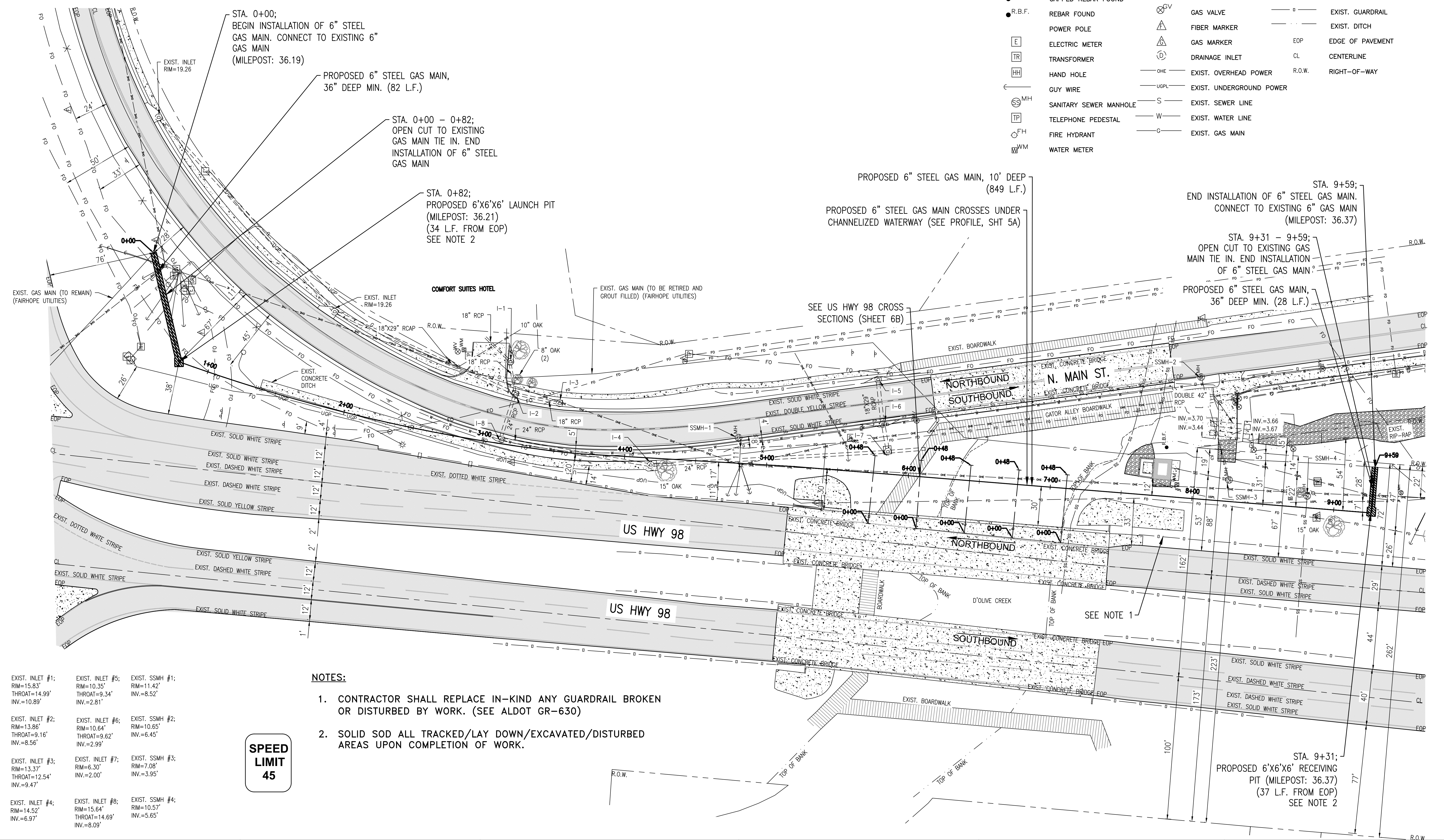

STA. 0+00;
BEGIN INSTALLATION OF 6" STEEL
GAS MAIN. CONNECT TO EXISTING 6"
GAS MAIN
(MILEPOST: 36.19)

PROPOSED 6" STEEL GAS MAIN,
36" DEEP MIN. (82 L.F.)

STA. 0+00 - 0+82;
OPEN CUT TO EXISTING
GAS MAIN TIE IN. END
INSTALLATION OF 6" STEEL
GAS MAIN

STA. 0+82;
PROPOSED 6'X6' LAUNCH PIT
(MILEPOST: 36.21)
(34 L.F. FROM EOP)
SEE NOTE 2

PROPOSED 6" STEEL GAS MAIN, 10' DEEP
(849 L.F.)

PROPOSED 6" STEEL GAS MAIN CROSSES UNDER
CHANNELIZED WATERWAY (SEE PROFILE, SHT 5A)

STA. 9+59;
END INSTALLATION OF 6" STEEL GAS MAIN.
CONNECT TO EXISTING 6" GAS MAIN
(MILEPOST: 36.37)

STA. 9+31 - 9+59;
OPEN CUT TO EXISTING GAS
MAIN TIE IN. END INSTALLATION
OF 6" STEEL GAS MAIN

PROPOSED 6" STEEL GAS MAIN,
36" DEEP MIN. (28 L.F.)

NOTES:

1. CONTRACTOR SHALL REPLACE IN-KIND ANY GUARDRAIL BROKEN OR DISTURBED BY WORK. (SEE ALDOT GR-630)
2. SOLID SOD ALL TRACKED/LAY DOWN/EXCAVATED/DISTURBED AREAS UPON COMPLETION OF WORK.

**SPEED
LIMIT
45**

EXIST. INLET #1: RIM=15.83' THROAT=14.99' INV.=10.89'	EXIST. INLET #5: RIM=10.35' THROAT=9.34' INV.=2.81'	EXIST. SSMH #1: RIM=11.42' INV.=8.52'
EXIST. INLET #2: RIM=13.86' THROAT=9.16' INV.=8.56'	EXIST. INLET #6: RIM=10.64' THROAT=9.62' INV.=2.99'	EXIST. SSMH #2: RIM=10.65' INV.=6.45'
EXIST. INLET #3: RIM=13.37' THROAT=12.54' INV.=9.47'	EXIST. INLET #7: RIM=6.30' INV.=2.00'	EXIST. SSMH #3: RIM=7.08' INV.=3.95'
EXIST. INLET #4: RIM=14.52' INV.=6.97'	EXIST. INLET #8: RIM=15.64' THROAT=14.69' INV.=8.09'	EXIST. SSMH #4: RIM=10.57' INV.=5.65'

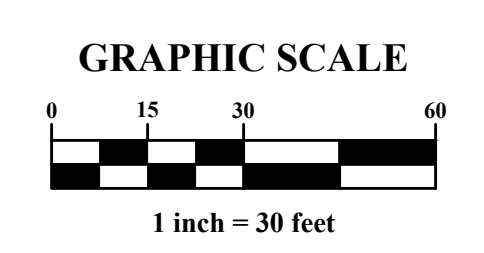

UNDERGROUND UTILITY NOTE:
UNDERGROUND UTILITY LOCATIONS SHOWN ARE APPROXIMATE AND ARE BASED ON INFORMATION PROVIDED. THE UTILITIES SHOWN MAY NOT BE A COMPLETE REPRESENTATION OF ALL UTILITY LINES IN THE PROJECT AREA. CONTRACTOR IS REQUIRED TO CONTACT ALABAMA ONE CALL PRIOR TO DIGGING (1-800-292-8525) (WWW.ALCALL.COM). OTHER UTILITIES (INCLUDING PRIVATE UTILITIES OUTSIDE A PUBLIC RIGHT-OF-WAY) THAT DO NOT PARTICIPATE IN THE ALABAMA ONE CALL LINE LOCATION SERVICE NEED TO BE CONTACTED INDIVIDUALLY AND/OR PHYSICALLY LOCATED BY THE CONTRACTOR.

SITE PLAN
D'OLIVE CREEK
CITY OF FAIRHOPE GAS

SCALE: 1" = 30'
DATE: APRIL, 2024
DRAWN BY: KT
CHECKED BY: SD
SHEET: 05 OF 07

DWG: INFO: SA1 - CLEVELAND - 177 - D'OLIVE CREEK CROSSING CITY FAIRHOPE CIVIL ENGINEERING PRODUCTION: DWG SITE PLAN D'OLIVE CREEK 4-29-24.DWG - 4/30/2024 10:58:23 AM

D:\WG\INFO\S\1-01\05\23-177-D'OLIVE CREEK CROSSING CITY FAIRHOPE CIVIL ENGINEERING\PRODUCTION\DWG\SITE PLAN\D'OLIVE CREEK 4-2024.DWG --4/25/2024 10:38:28 AM

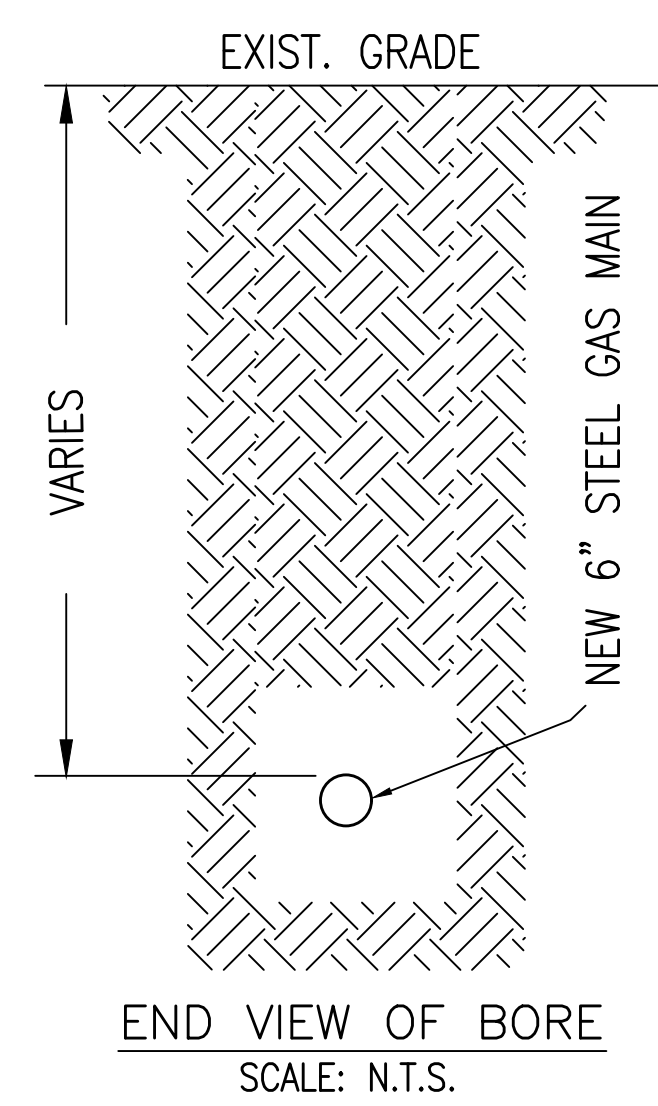
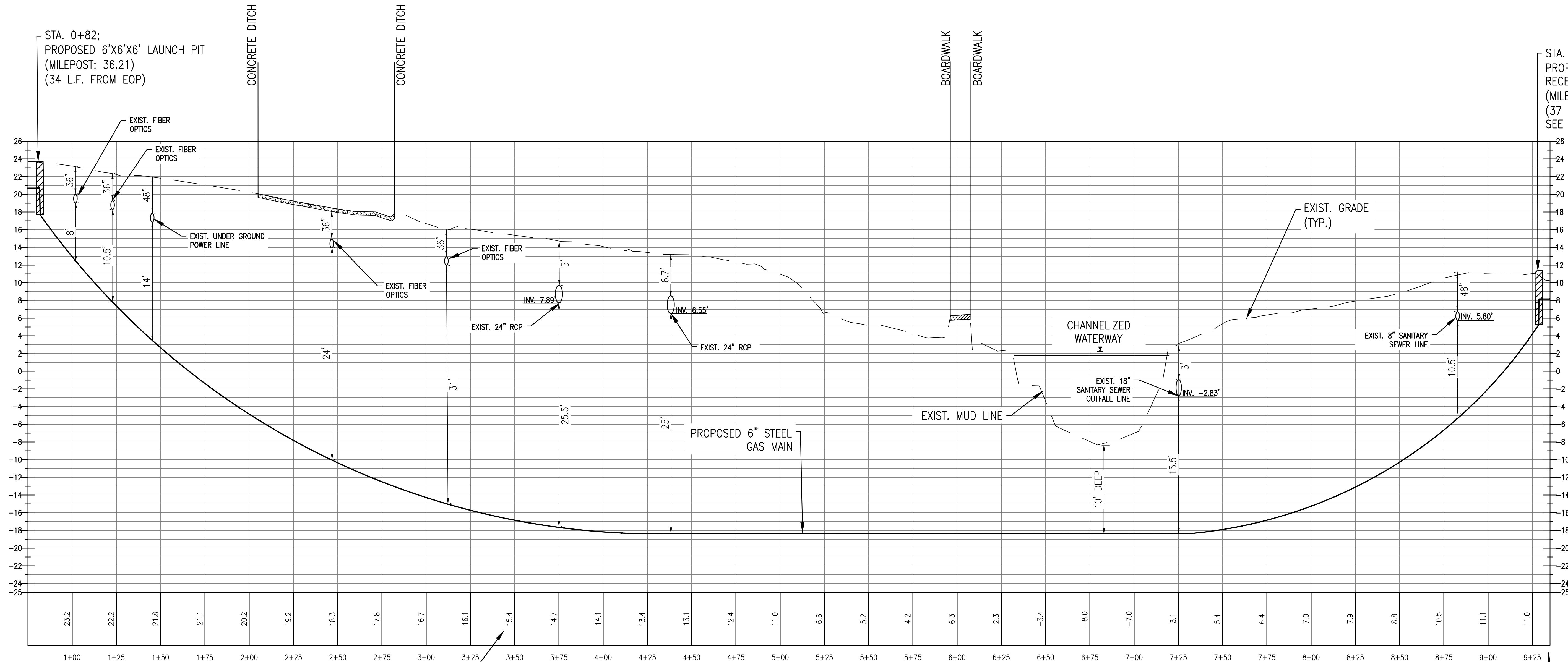

EXIST. GRADE ELEV. (TYP.)

D'OLIVE CREEK

STA. 9+31;
PROPOSED 6'x6'x6'
RECEIVING PIT
(MILEPOST: 36.37)
(37 L.F. FROM EOP)
SEE NOTE 2

NUMBER:	REVISION:	DATE:
01	PER A.L.D.O.T. COMMENTS	4-29-24

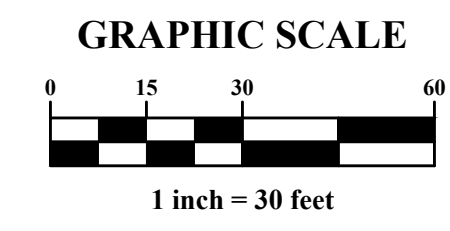

CREEK CROSSING PROFILE

D'OLIVE CREEK

CITY OF FAIRHOPE GAS

SCALE: 1"=30' H., 1"=6' V.
DATE: APRIL, 2024
DRAWN BY: KT
CHECKED BY: SD
SHEET: 05A OF 07

PROPOSED 6" STEEL GAS MAIN, 10' DEEP
(849 L.F.)

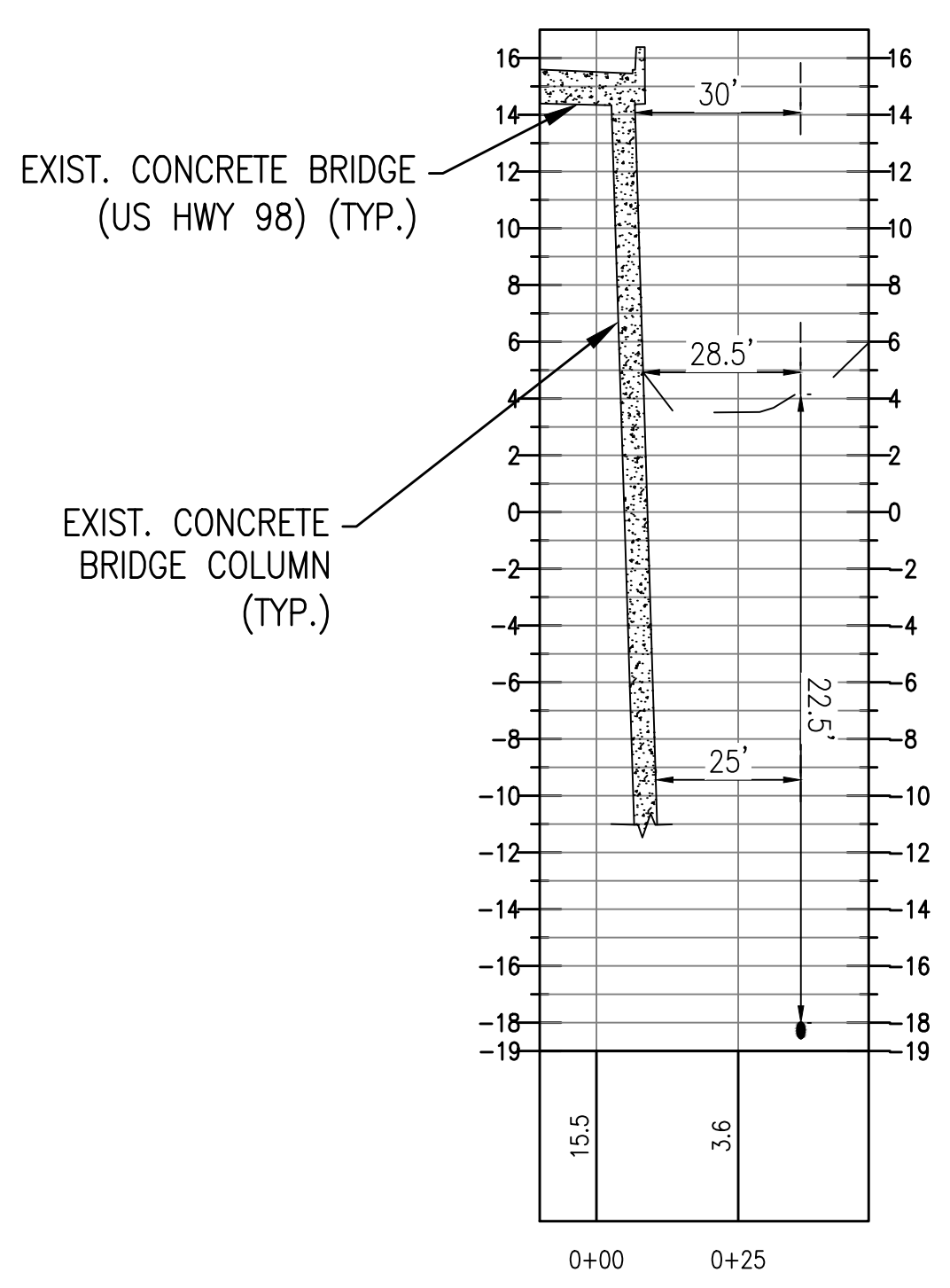
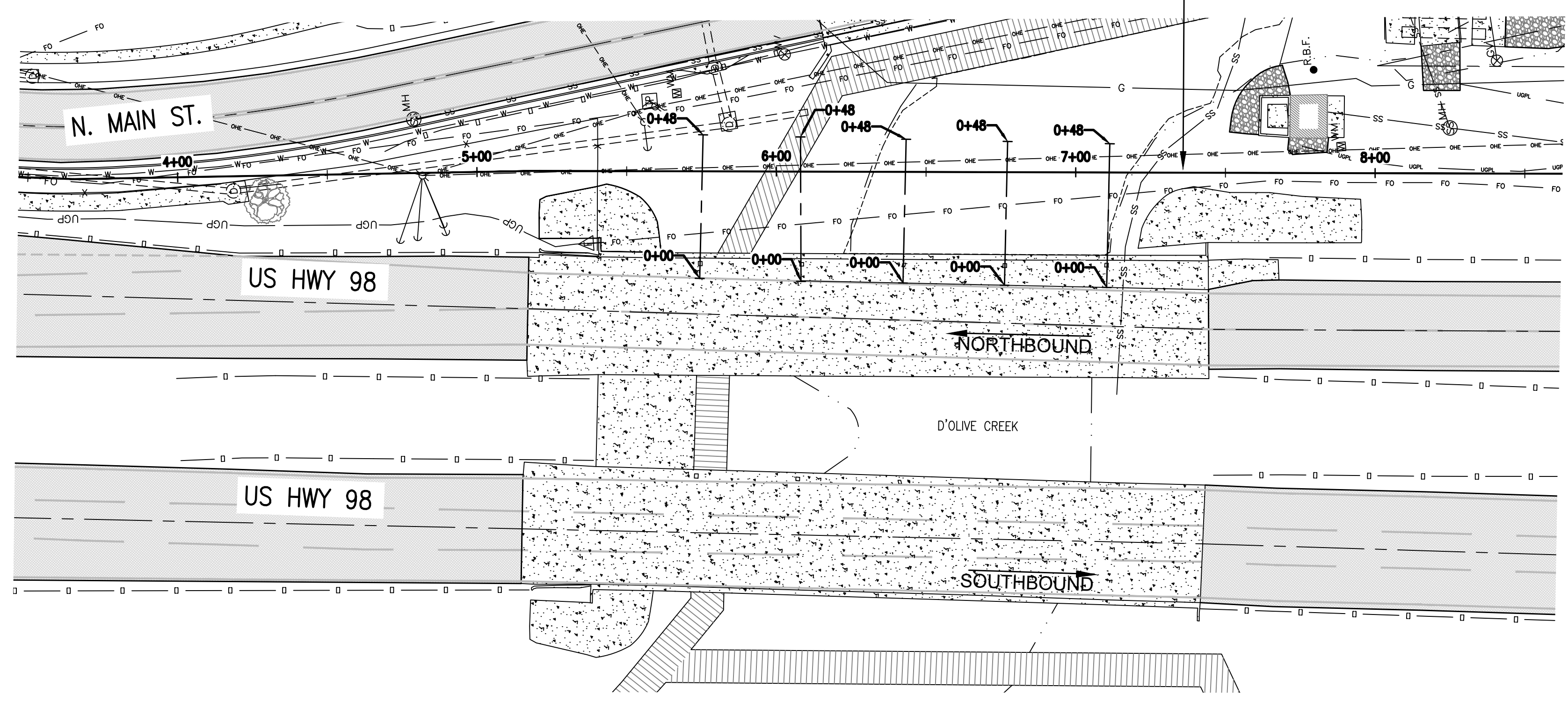

STA. 5+75

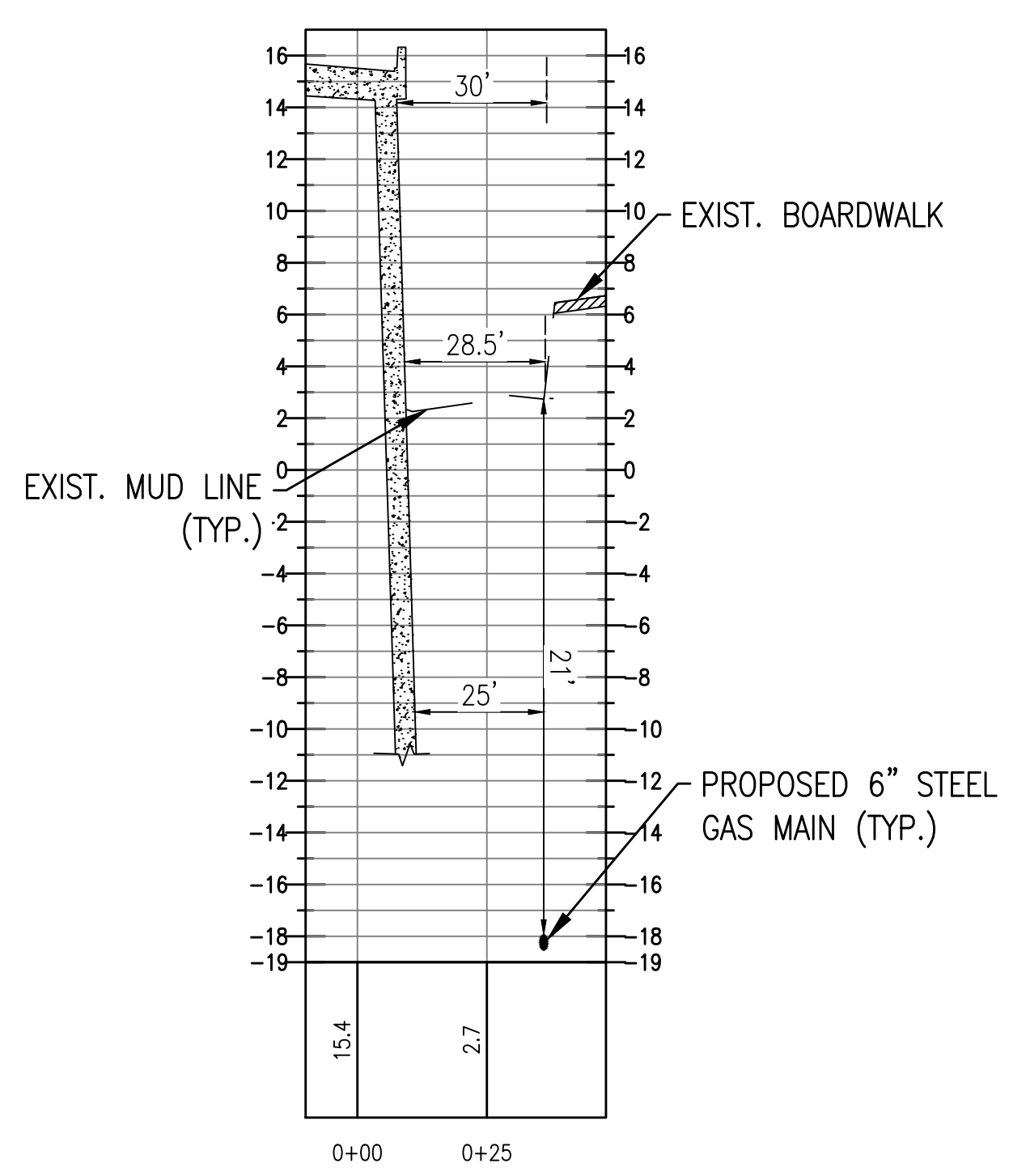

STA. 6+10

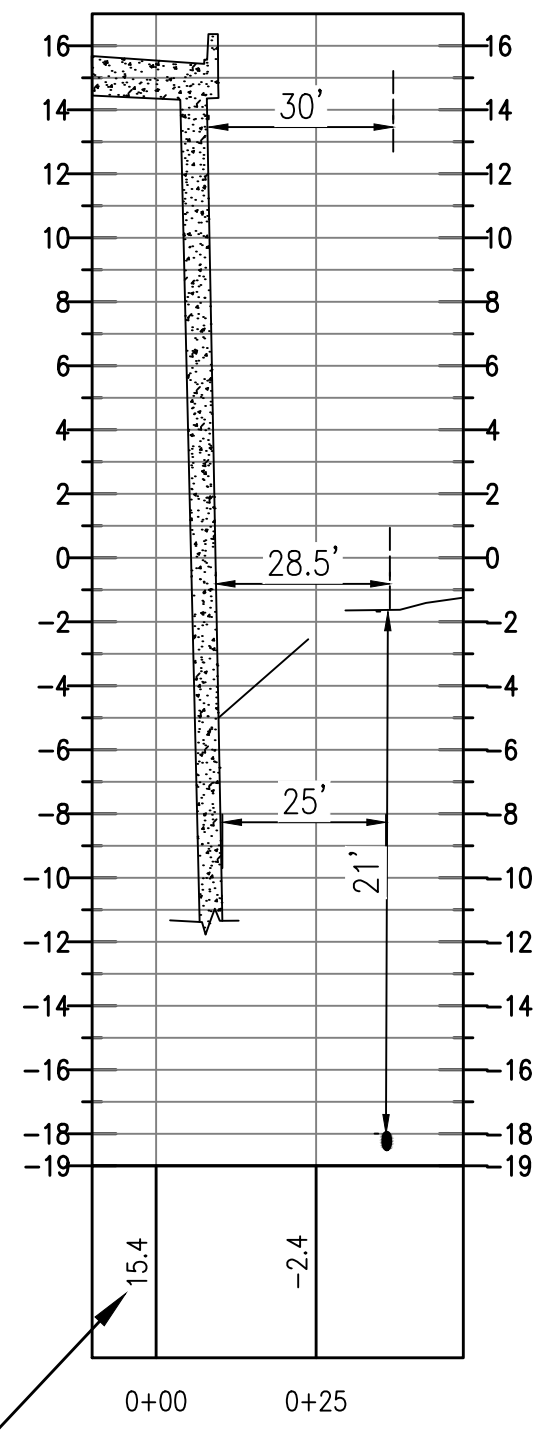

STA. 6+45

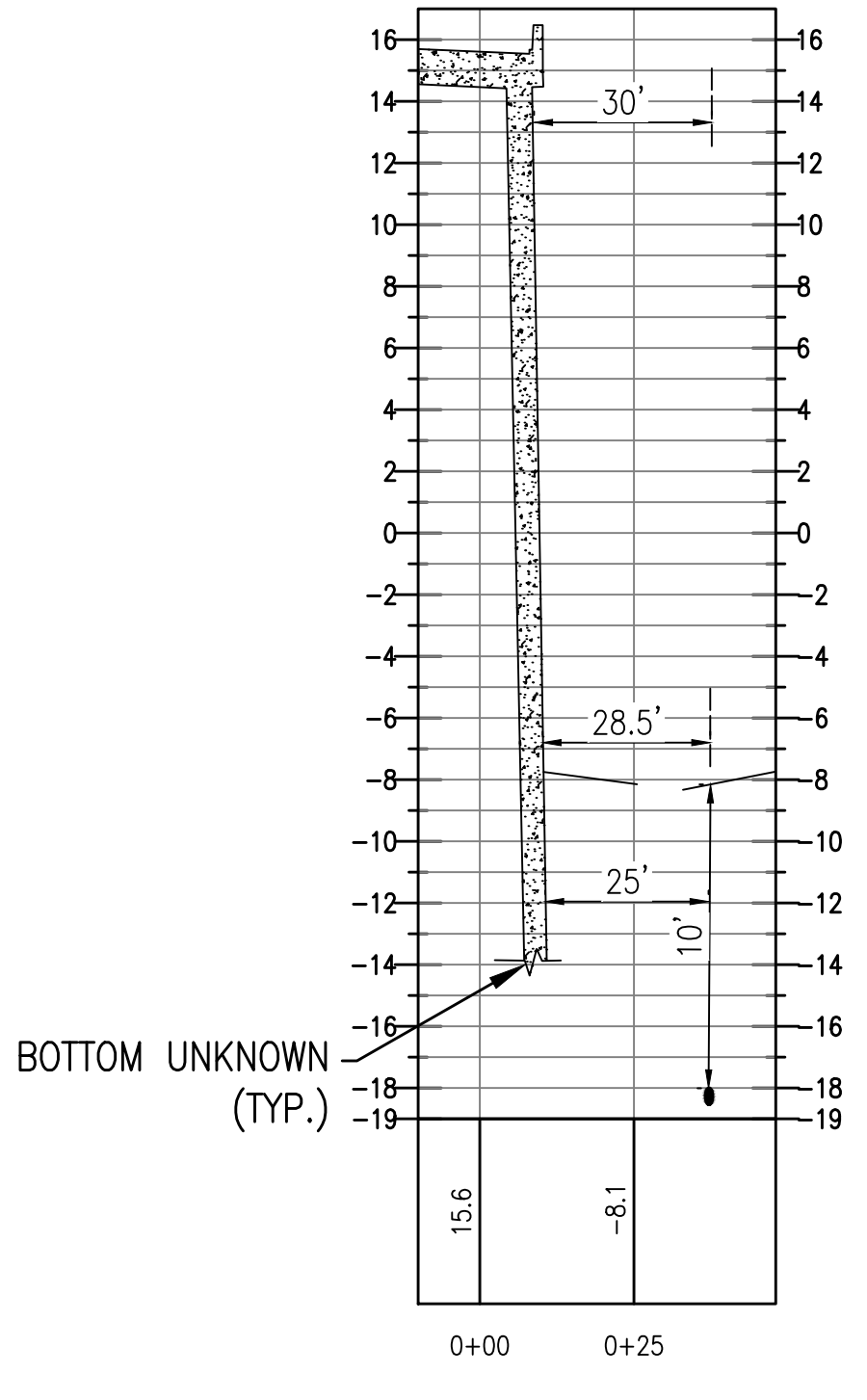

STA. 6+75

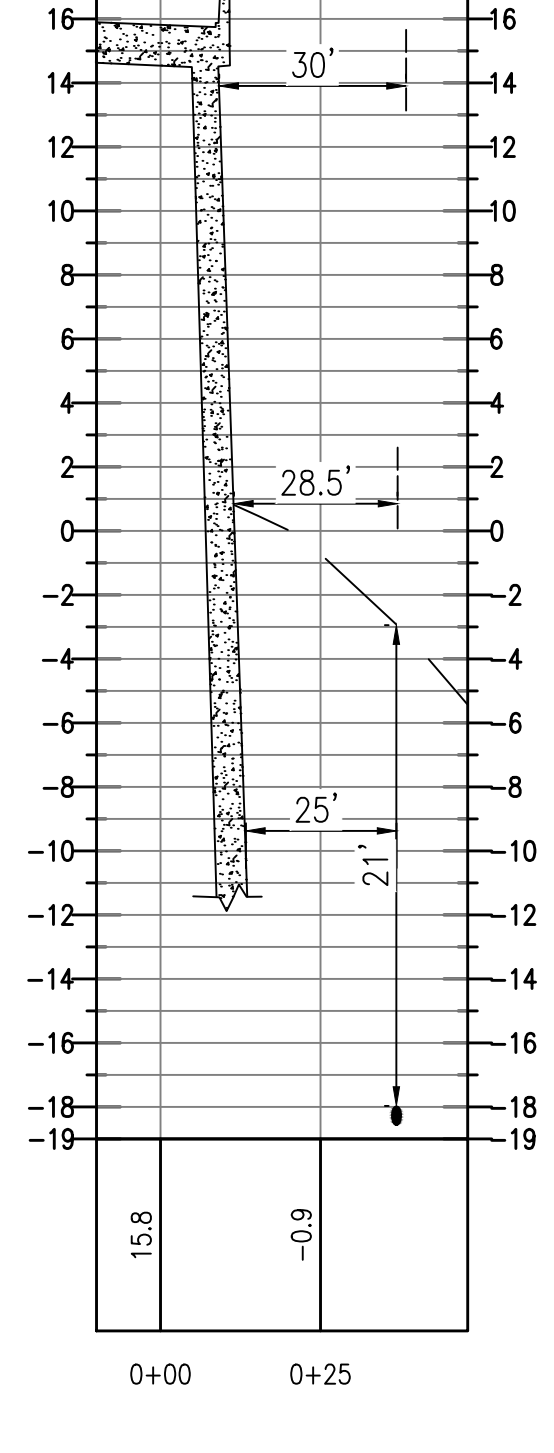

STA. 7+10

D:\WORK\2024\1-2125\24-177 D'OLIVE CREEK CROSSING CITY FAIRHOPE CIVIL ENGINEERING\PRODUCTION\DWG\SITE PLAN D'OLIVE CREEK 4-2024.DWG --4/25/2024 10:38:34 AM

NUMBER:	REVISION:	DATE:
01	PER A.L.D.O.T. COMMENTS	4-29-24

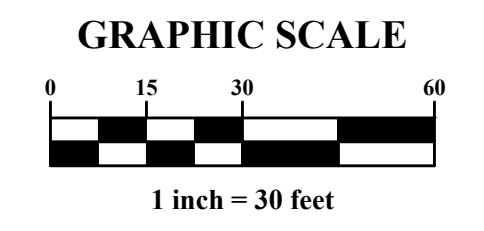

30673 Sgt. E. I. "Boots" Thomas Drive, Spanish Fort, AL 36527 Phone: (251) 544-7900

CROSS SECTIONS
D'OLIVE CREEK
CITY OF FAIRHOPE GAS

SCALE: 1"=30' H., 1"=6' V.
DATE: APRIL, 2024
DRAWN BY: KT
CHECKED BY: SD
SHEET: 05B OF 07

LEGEND

- C.R.F. CAPPED REBAR FOUND
- R.B.F. REBAR FOUND
- ⊠ E. ELECTRIC METER
- ⊠ TR. TRANSFORMER
- ⊠ HH. HAND HOLE
- ← GUY WIRE
- ⊠ SS. SANITARY SEWER MANHOLE
- ⊠ TP. TELEPHONE PEDESTAL
- ⊠ FH. FIRE HYDRANT
- ⊠ WM. WATER METER
- X — EXIST. FENCE
- □ — EXIST. GUARDRAIL
- - - - EXIST. DITCH
- ⊗ WV. WATER VALVE
- ⊗ GV. GAS VALVE
- ⊠ F. FIBER MARKER
- ⊠ G. GAS MARKER
- ⊠ D. DRAINAGE INLET
- OHE — EXIST. OVERHEAD POWER
- UGPL — EXIST. UNDERGROUND POWER
- S — EXIST. SEWER LINE
- W — EXIST. WATER LINE
- G — EXIST. GAS MAIN
- EOP — EDGE OF PAVEMENT
- CL — CENTERLINE
- R.O.W. — RIGHT-OF-WAY

EROSION CONTROL LEGEND

- INLET PROTECTION DEVICE (TYP.)
- x — TYPE "A" SILT FENCE (TYP.)
- ⊠ WATTLE DITCH CHECK (TYP.)

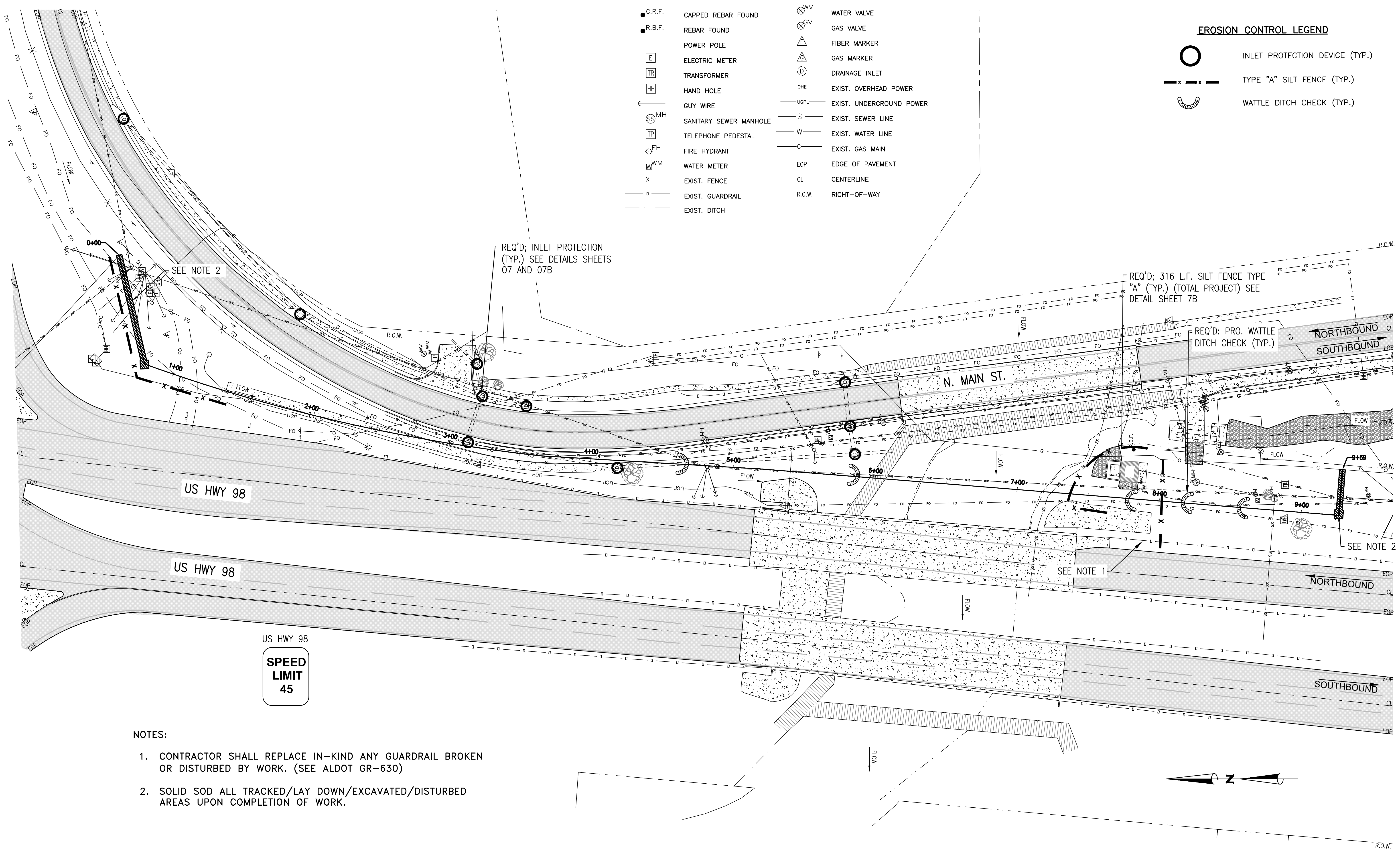

NOTES:

1. CONTRACTOR SHALL REPLACE IN-KIND ANY GUARDRAIL BROKEN OR DISTURBED BY WORK. (SEE ALDOT GR-630)
2. SOLID SOD ALL TRACKED/LAY DOWN/EXCAVATED/DISTURBED AREAS UPON COMPLETION OF WORK.

US HWY 98
SPEED
LIMIT
45

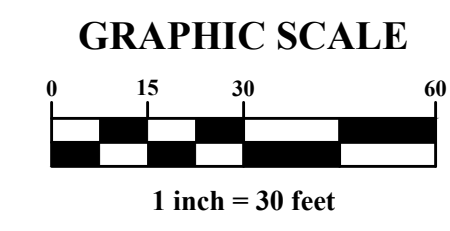

Sawgrass
ENGINEERING - SURVEYING - CONSTRUCTION MANAGEMENT
30673 Sgt. E. I. "Boots" Thomas Drive, Spanish Fort, AL 36527 Phone: (251) 544-7900

UNDERGROUND UTILITY NOTE:
UNDERGROUND UTILITY LOCATIONS SHOWN ARE APPROXIMATE AND ARE BASED ON INFORMATION PROVIDED. THE UTILITIES SHOWN MAY NOT BE A COMPLETE REPRESENTATION OF ALL UTILITY LINES IN THE PROJECT AREA. CONTRACTOR IS REQUIRED TO CONTACT ALABAMA ONE CALL PRIOR TO DIGGING (1-800-292-8525) (WWW.A1CALL.COM). OTHER UTILITIES (INCLUDING PRIVATE UTILITIES OUTSIDE A PUBLIC RIGHT-OF-WAY) THAT DO NOT PARTICIPATE IN THE ALABAMA ONE CALL LINE LOCATION SERVICE NEED TO BE CONTACTED INDIVIDUALLY AND/OR PHYSICALLY LOCATED BY THE CONTRACTOR.

EROSION CONTROL PLAN
D'OLIVE CREEK
CITY OF FAIRHOPE GAS

SCALE: 1" = 30'
DATE: APRIL, 2024
DRAWN BY: KT
CHECKED BY: SD
SHEET: 06 OF 07

D:\PROJECTS\1-CLAYTON\177 D'OLIVE CREEK CROSSING CITY FAIRHOPE CIVIL ENGINEERING\PRODUCTION DWG\SITE PLAN D'OLIVE CREEK 4-29-24.DWG --4/30/2024 10:38:38 AM

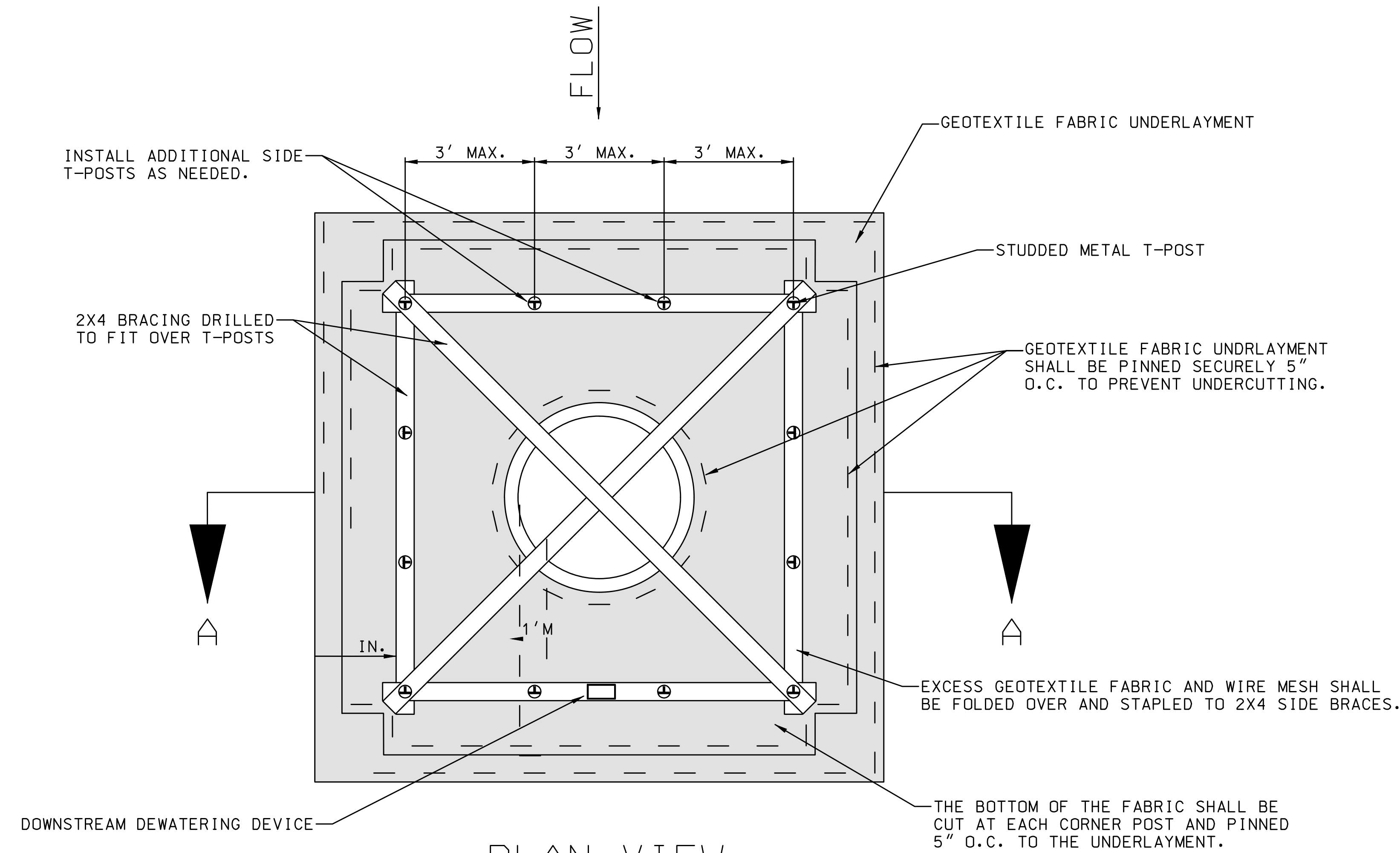

PLAN VIEW

- NOTES:
1. THE TOP OF THE REQUIRED GEOTEXTILE FABRIC SHALL BE 6" LOWER THAN THE SHOULDER ELEVATION IN ANY AREA CRITICALLY SUSCEPTIBLE TO FLOODING.
 2. DEWATERING HOLES SHALL BE 1"-1.5" IN DIAMETER AND SPACED 2"-3" APART TO ALLOW FOR DEWATERING IN NO MORE THAN 48 HOURS.
 3. FASTEN DEWATERING DEVICE TO THE 2X4 SIDE BRACE.
 4. STAPLE GEOTEXTILE FABRIC TO DEWATERING DEVICE AND CUT CROSS SLITS IN THE FILTER FABRIC AT THE HOLE LOCATIONS TO ALLOW WATER TO FLOW THROUGH.
 5. INLET PROTECTION DEVICE SHALL ONLY BE PAID AS INLET PROTECTION STAGE 3 OR 4.
 6. SILT FENCE INLET PROTECTION SHALL NOT BE UTILIZED DURING STAGE 1 AND STAGE 2 INLET CONSTRUCTION SEE SPECIAL DRAWING No ESC-400-1 FOR INLET PROTECTION TYPICAL APPLICATIONS AND DETAILS.

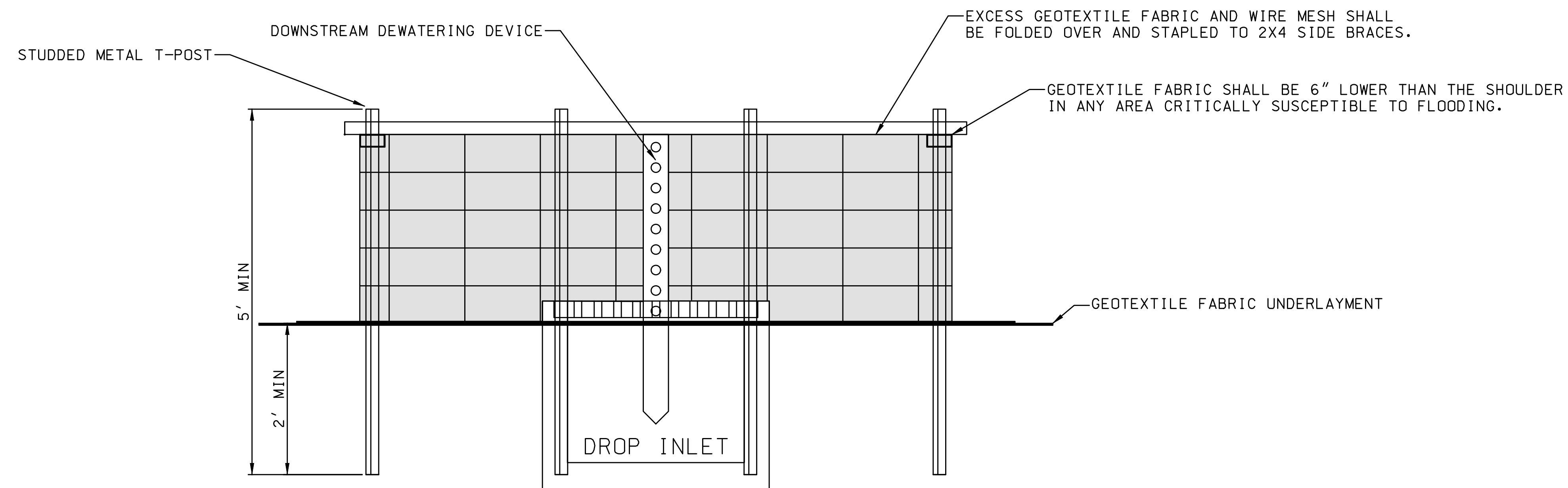

SECTION A-A

NUMBER:	REVISION:	DATE:
01	PER A.L.D.O.T. COMMENTS	4-29-24



EROSION CONTROL DETAILS

D'OLIVE CREEK

CITY OF FAIRHOPE GAS

N.T.S.
DATE: APRIL, 2024
DRAWN BY: KT
CHECKED BY: SD
SHEET: 04 OF 07

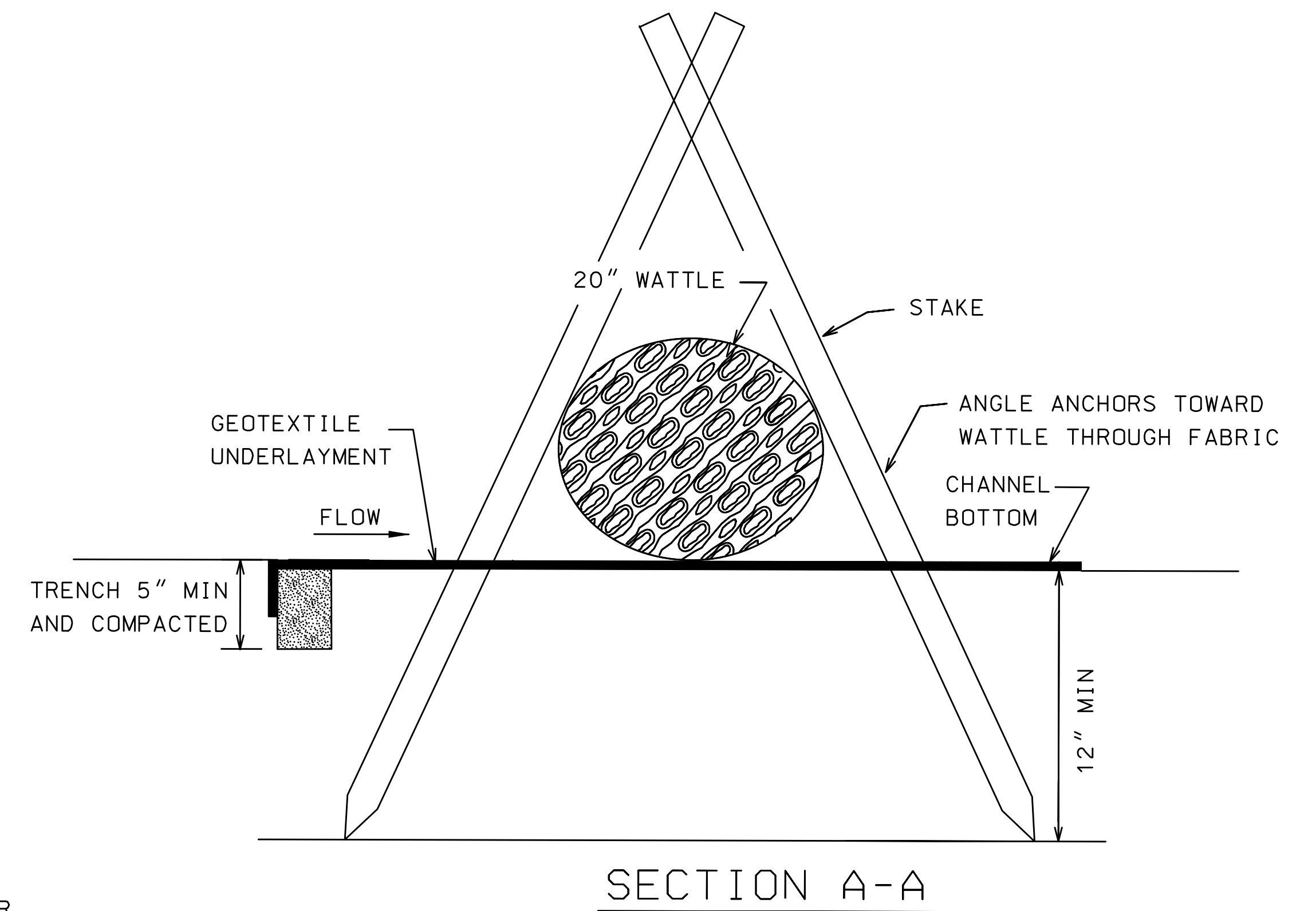
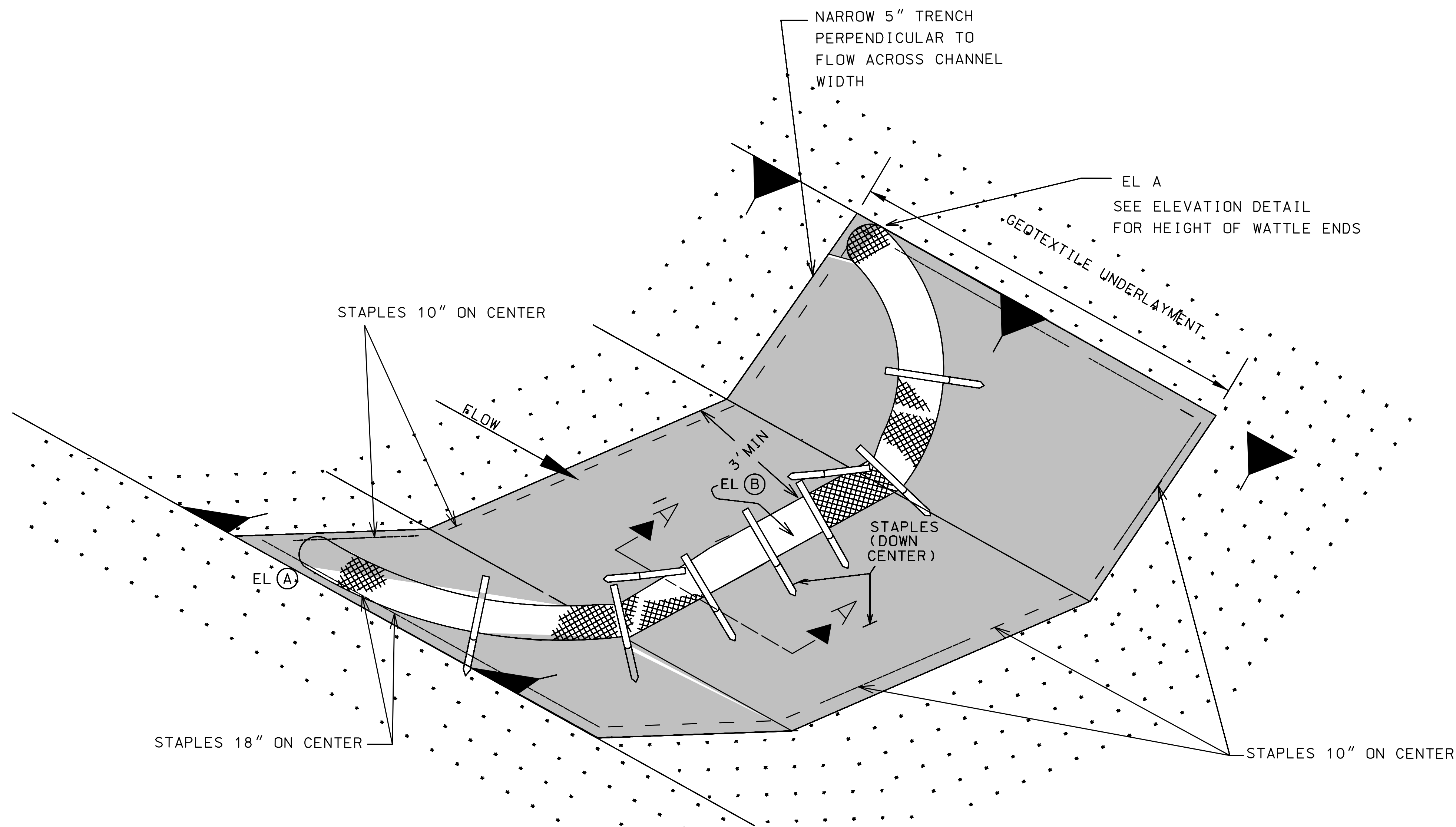

DETAIL (DITCH CHECK)

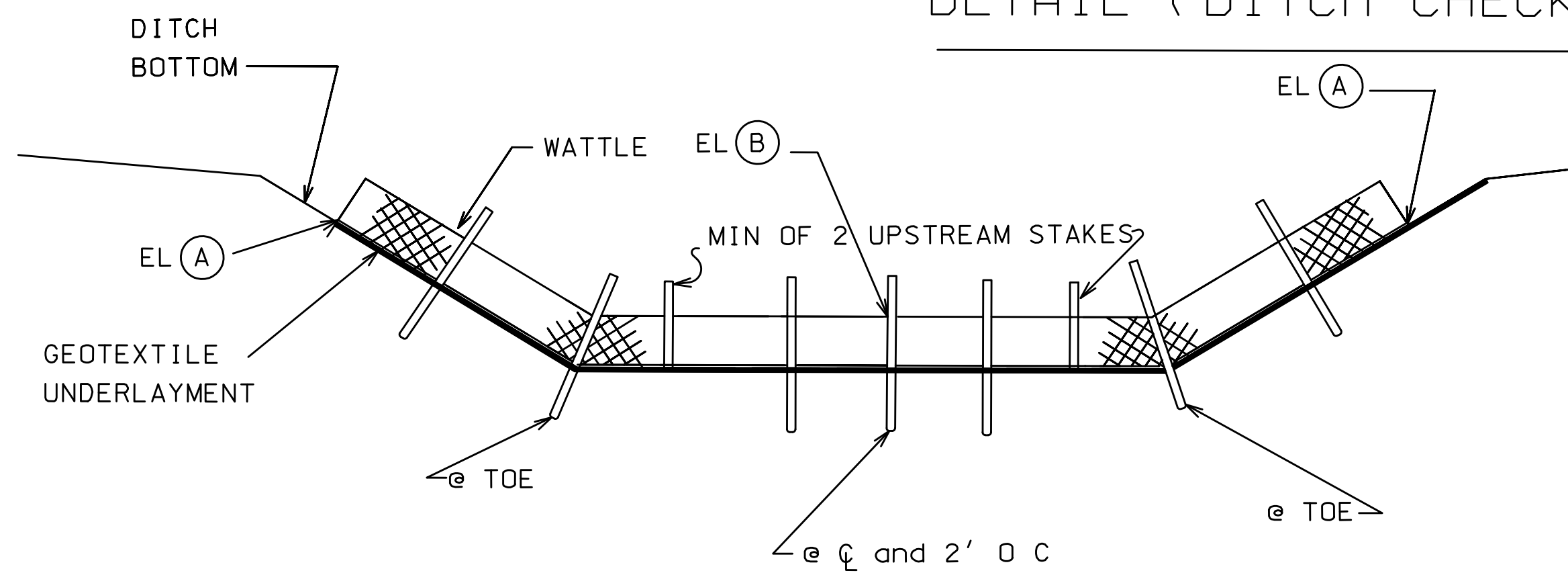

ELEVATION DETAIL

NOTE: END POINTS (A) MUST BE HIGHER THAN FLOWLINE POINT (B)

NOTES:

1. MINIMUM RECOMMENDED PLACEMENT INTERVAL BETWEEN WATTLE DITCH CHECK IS 100 FEET UNLESS SHOWN OTHERWISE ON THE PLANS OR APPROVED BY THE ENGINEER. SEE SPACING GUIDANCE ON ESC-300-1.
2. ANCHORING STAKES SHALL BE SIZED, SPACED, DRIVEN, AND BE OF A MATERIAL THAT EFFECTIVELY SECURES THE CHECK. STAKE SPACING SHALL BE A MAXIMUM OF TWO FEET.
3. WATTLES SHOULD NOT BE USED IN HARD BOTTOM CHANNELS.
4. STAPLES SPACED 18 INCHES APART, ALONG THE CHANNEL EDGES AND DOWN THE CENTER OF THE CHANNEL. STAPLES SPACED 10 INCHES APART, ACROSS THE UPSTREAM AND DOWNSTREAM EDGES.

WATTLE DITCH CHECK SELECTION GUIDELINES

WATTLE DITCH CHECKS ARE APPROPRIATE FOR VELOCITY REDUCTION AND CONTROL OF SEDIMENT TRANSPORT UNDER LOW TO MEDIUM FLOW CONDITIONS NOT EXCEEDING 1.0 CU FT/SEC.

NUMBER:	REVISION:	DATE:
01	PER A.L.D.O.T. COMMENTS	4-29-24



EROSION CONTROL DETAILS

D' OLIVE CREEK

CITY OF FAIRHOPE GAS

N.T.S.
DATE: APRIL, 2024
DRAWN BY: KT
CHECKED BY: SD
SHEET: 07A OF 07

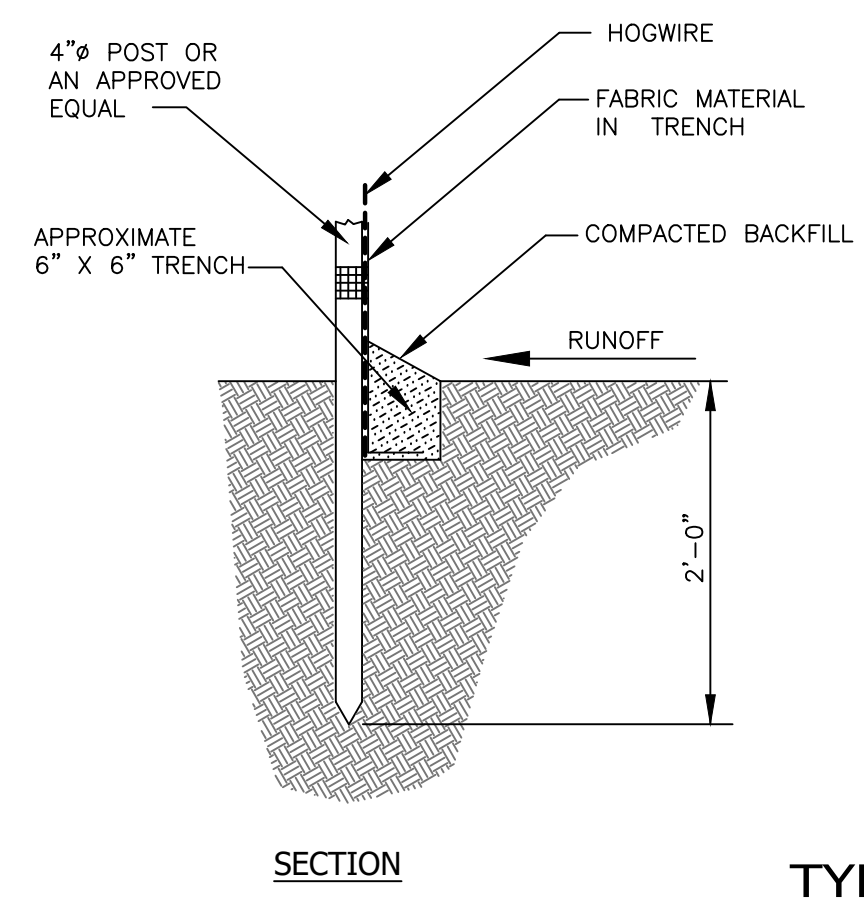
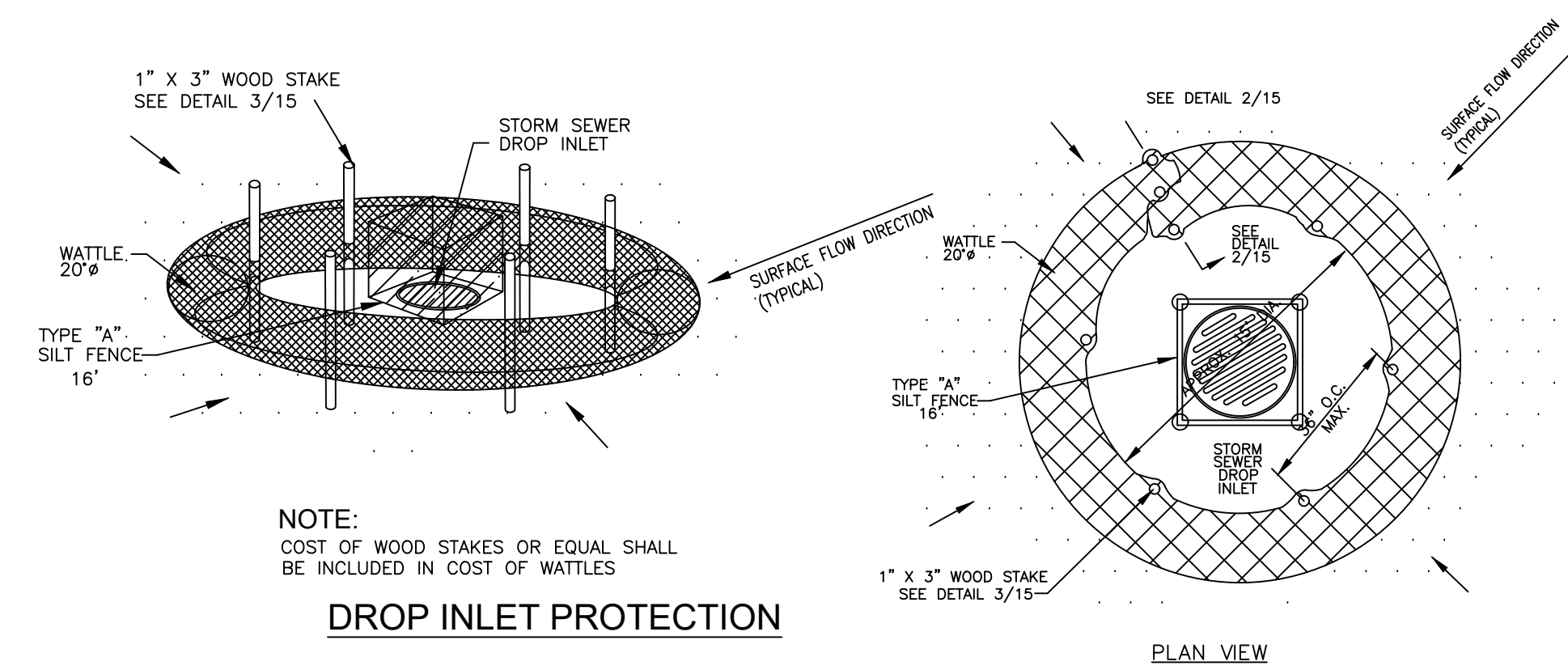

TYPICAL SILT FENCE INSTALLATION

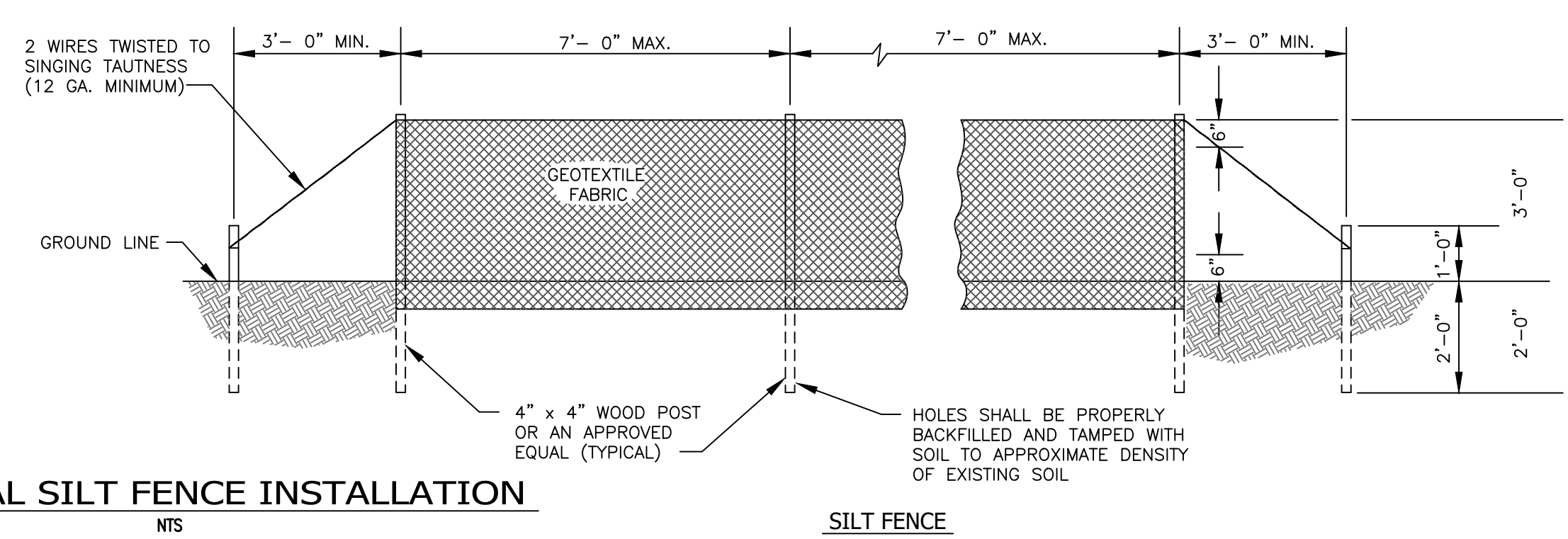

SILT FENCE

GENERAL NOTES

1. TYPE "A" SILT FENCE SHALL BE USED IN AREAS OF CONCENTRATED FLOW.
2. SILT FENCES ARE TEMPORARY EROSION CONTROL ITEMS THAT SHALL BE ERRECTED OPPOSITE ERODIBLE AREAS SUCH AS NEWLY GRADED FILL SLOPES AND ADJACENT TO STREAMS AND CHANNELS.
3. SILT FENCE SHOULD BE PLACED WELL INSIDE PROPERTY BOUNDARY AND ALONG EDGE OF CLEARING LIMITS. THIS WILL ALLOW ROOM FOR A BACK-UP FENCE IF FIRST BECOMES FULL. SILT FENCES SHALL BE IN PLACE PRIOR TO ANY CONSTRUCTION OPERATION.
4. WHEREVER POSSIBLE, SILT FENCES SHALL BE CONSTRUCTED ACROSS A FLAT AREA IN THE SHAPE OF A HORSESHOE. THIS AIDS IN PONDING OF RUNOFF AND FACILITATES SEDIMENTATION.
5. AFTER THE CONSTRUCTION AREA IS STABILIZED AND EROSION ACTIVITY CURTAILED, SILT FENCES SHALL BE REMOVED.
6. RING FASTENERS USED TO SECURE GEOTEXTILES TO WOVEN WIRE SHALL BE 13 GA. (AMERICAN).
7. IF WOOD POSTS ARE USED, STAPLES FOR SECURING WOVEN WIRE TO POSTS SHALL BE NINE (9) GAUGE, GALVANIZED, 1 1/2" LONG, FIVE (5) PER POST @ APPROXIMATELY 1'-0" ON CENTER.
8. WOVEN WIRE TO BE 12 1/2 GAUGE (MINIMUM).

SPECIFICATIONS

CURRENT ALABAMA DEPARTMENT OF TRANSPORTATION

NUMBER:	REVISION:	DATE:
01	PER A.L.D.O.T. COMMENTS	4-29-24

ENGINEERING - SURVEYING - CONSTRUCTION MANAGEMENT

30673 Sgt. E. I. "Boots" Thomas Drive, Spanish Fort, AL 36527 Phone: (251) 544-7900

EROSION CONTROL DETAILS
D' OLIVE CREEK
CITY OF FAIRHOPE GAS

N.T.S.
DATE: APRIL, 2024
DRAWN BY: KT
CHECKED BY: SD
SHEET: 07B OF 07