



**CITY OF FAIRHOPE  
INVITATION TO BID**

**SEALED BIDS will be received by the City of Fairhope of Baldwin County, Alabama, in the City of Fairhope's City Services and Public Utilities Building located at, 555 South Section St. Fairhope, Alabama, until 10:00 A.M. Thursday, February 8, 2024, and then publicly opened thereafter, for furnishing all labor and materials, and performing all work required by the City of Fairhope and described as follows:**

**Bid Number 24-020-2024-PWI-001  
Pine Street One-Way Conversion and Parking Project  
Public Works Project No. 2024-PWI 001**

The City of Fairhope is requesting responses from qualified contractors to provide all material, equipment, labor, and incidentals to conduct Resurfacing, Restoration and Rehabilitation (RRR), retrofitting (road diet and conversion to one-way traffic flow), striping, marking, on street public parking (using concrete paver system), ADA sidewalk improvements, minimal drainage improvements and overall streetscape improvements for the block of Pine Street between Section Street and Bancroft Avenue in Fairhope's Central Business District (CBD). It is expected that the winning bidder can complete this project in sixty (60) calendar days, no exceptions for holidays, following a fifteen (15) day Notice to Proceed Period.

Bid documents will be posted on the City of Fairhope Website: [www.FairhopeAL.gov](http://www.FairhopeAL.gov) or a copy may be obtained by e-mailing: [Purchasing@FairhopeAL.gov](mailto:Purchasing@FairhopeAL.gov). Specifications are on file and may be seen in the Purchasing Department of the City of Fairhope, Alabama, 555 S. Section Street. Prior to opening, Bid packages may be picked up at that location during normal operation, between 7:00 am and 4:00 pm local time.

Questions or comments pertaining to this bid must be presented in writing, sent as e-mail to the attention of the Purchasing Manager, Erin Wolfe, 555 South Section St., Fairhope, AL 36532, e-mail: [Purchasing@FairhopeAL.gov](mailto:Purchasing@FairhopeAL.gov), by Thursday, February 1, 2024, at 11:00 A.M. or will be forever waived.

There will be a non-mandatory pre-bid meeting on Tuesday, January 30, 2024, at 10:00 A.M. at the City Services and Public Utilities Building located at 555 South Section Street, Fairhope, AL.

The City of Fairhope is an Equal Opportunity Employer and requires that all **BIDDERS** comply with the Equal Employment Opportunity laws and the provisions of the CONTRACT Documents in this regard. The **CITY** also encourages and supports the utilization of Minority Business Enterprises on this and all public bids.

All bids must be on blank bid forms provided in the Bid Documents. All bids, with their guarantee (when required), must be enclosed in a sealed, opaque envelope, clearly identified on the outside as a "**Sealed Bid**" with **Item Name, Bid Number, City of Fairhope's Name and Address and CONTRACTOR's Name and Address**. Each bid must be in a separate envelope. Bids made out in pencil will not be accepted. Failure to observe the instructions contained herein will constitute grounds for rejection of your bid. The **City** reserves the right to accept or reject all bids or any portion thereof, and to waive informalities and to furnish any item of material or work to change the amount of the CONTRACT, whichever is in the best interest of the City of Fairhope.

No bids will be considered unless the **CONTRACTOR**, whether resident or non-resident of Alabama, is properly qualified to submit a proposal for this type of work in accordance with all applicable laws of the State of Alabama. Where applicable, this shall include evidence of holding a current license from the State Licensing board for General BIDDERS, Montgomery, Alabama, as required by Chapter 8 of Title 34, of the Code of Alabama, 1975. In addition, the Awarded Vendor, if non-resident of the State, and if a corporation, shall show evidence of having qualified with the Secretary of State to do business in the State of Alabama. **CONTRACTOR** must have a current business license or purchase a business license with the City of Fairhope prior to work performed. No bids shall be withdrawn for the period of thirty (30) days subsequent to the opening of proposals without the consent of the City of Fairhope, Baldwin County, Alabama. Once completed, a tabulation of the responsive and responsible bids will be available for public viewing by visiting the following web address: [www.FairhopeAL.gov](http://www.FairhopeAL.gov).



**INVITATION TO BID  
NO. 24-020-2024-PWI-001  
PINE STREET ONE-WAY CONVERSION  
AND PARKING PROJECT  
PROJECT NO. 2024-PWI 001**

**CITY OF FAIRHOPE  
SHERRY SULLIVAN, MAYOR**

## TABLE OF CONTENTS

Invitation and Instruction to Bidders.....	I
Scope of Work.....	II
Bid Response Form.....	III
Contractor Information.....	IV
Insurance.....	V
Sample Contract.....	VI
Standard Terms and Conditions.....	VII
Alabama Immigration Act Contract Requirements.....	VIII
Invitation Summary.....	IX
Bid Bond.....	X
Performance Bond.....	XI
Labor and Materials Bond.....	XII
Closeout Documents.....	XIII
Bid Set Drawings .....	Attachment

**ITEM I  
INVITATION AND INSTRUCTIONS TO BIDDERS**

**1.00 BID INVITATION**

Notice is hereby given that the **City of Fairhope ("CITY")** will receive bids on the project described herein. Qualified **BIDDERS** are invited to bid on this CONTRACT.

**1.01 BID NO.:** 24-020-2024-PWI-001  
**NAME:** Pine Street One-Way Conversion and Parking Project

**1.02 SUMMARY**

The City of Fairhope is requesting responses from qualified contractors to provide all material, equipment, labor, and incidentals to conduct Resurfacing, Restoration and Rehabilitation (RRR), retrofitting (road diet and conversion to one-way traffic flow), striping, marking, on street public parking (using concrete paver system), ADA sidewalk improvements, minimal drainage improvements and overall streetscape improvements for the block of Pine Street between Section Street and Bancroft Avenue in Fairhope's Central Business District (CBD). It is expected that the winning bidder can complete this project in sixty (60) calendar days, no exceptions for holidays, following a fifteen (15) day Notice to Proceed Period.

**1.03 BID DEADLINE**

Bids will be received until **10:00 A.M. local time, Thursday, February 8, 2024**, at the City Services and Public Utilities Building, 555 South Section St., Fairhope, Alabama, and publicly opened shortly thereafter.

**1.04 AVAILABILITY OF DOCUMENTS**

Bid Documents may be obtained on the City's website at [www.FairhopeAL.gov/departments/purchasing/bids](http://www.FairhopeAL.gov/departments/purchasing/bids) or at the City Services and Public Utilities Building, 555 South Section Street., Fairhope, Alabama. One set of Bid Documents can be obtained free of charge.

**1.05 INQUIRIES**

Questions or comments pertaining to this bid must be presented in writing, sent as e-mail to the attention of the Purchasing Manager, Erin Wolfe, 555 South Section St., Fairhope, AL 36532, e-mail: [Purchasing@FairhopeAL.gov](mailto:Purchasing@FairhopeAL.gov), by Thursday, February 1, 2024, at 11:00 A.M. or will be forever waived.

**1.06 SITE EXAMINATION**

There will be a non-mandatory pre-bid meeting on Tuesday, January 30, 2024, at 10:00 A.M. at the City Services and Public Utilities Building located at 555 South Section Street, Fairhope, AL. This non-mandatory pre-bid meeting will serve as an opportunity for potential bidders to engage project stakeholders, review plans and ask questions.

The City of Fairhope will not furnish any labor, material, or supplies unless specifically stated in the CONTRACT Documents. **BIDDERS** must be properly licensed to perform the work as outlined in the Scope of Work. Awarded Vendor must have a current business license or purchase a business license with the City of Fairhope prior to bid being awarded.

Except for CONTRACTS funded in whole or in part by funds received from a federal agency, preference shall be given to resident **BIDDERS** on the same basis as the nonresident **BIDDERS** state awards CONTRACT to Alabama **BIDDERS** bidding under similar circumstances. Therefore, non-resident **BIDDERS** shall submit with their bid a written opinion of an attorney at law licensed to practice law in the non-resident **BIDDERS** state of domicile as to preferences granted by that state to entities doing business in that state when letting public contracts.



#### 1.07 **BID SECURITY**

Bids shall be accompanied by a Bid Security equal to 5% (percent) of the bid price, but in no event more than \$10,000.00. Bid Security shall be in the form of a Bid Bond or a cashier's check payable to The City of Fairhope. No Bid Security is required on bids less than \$10,000.00.

#### 1.08 **PERFORMANCE ASSURANCE AND INSURANCE**

The **BIDDER** to whom award is made shall provide a Performance Bond equal to 100% of the CONTRACT Amount and a Labor and Material Bond equal to 50% of the CONTRACT amount.

The accepted **BIDDER** shall also provide insurance as required in ITEM V.

#### 1.09 **DURATION OF OFFER**

Bids may be withdrawn in written or telegraphic request received from **BIDDER** prior to the time fixed for opening. No bid shall be withdrawn for a period of thirty (30) days subsequent to the opening of bids without the consent of the City Council of the City of Fairhope.

#### 1.10 **EQUAL OPPORTUNITY**

The City of Fairhope is an Equal Opportunity Employer and requires that all **BIDDERS** comply with the Equal Employment Opportunity laws and the provisions of the CONTRACT Documents in this regard. The City of Fairhope also encourages and supports the utilization of Minority Business Enterprises on this and all public bids.

#### 1.11 **BID SUBMISSION AND PREPARATION**

Sealed Bids, signed, executed, and dated, will be received by the City of Fairhope as noted in section 1.03 above. Submit one copy of the executed offer on the Bid Form provided, signed, and with the required Bid Security. **The bid shall be enclosed in a sealed opaque envelope approximately 9x12 inches or larger, clearly identified on the outside as a SEALED BID with the BID NAME, BID NUMBER, CITY'S NAME AND ADDRESS, CONTRACTOR'S NAME AND ADDRESS.**

Forms furnished, or copies thereof, shall be used, and strict compliance with the requirements of the invitation, these instructions, and the instructions printed on the forms is necessary. Special care should be exercised in the preparation of bids. **BIDDERS** must make their own estimates of the facilities and difficulties attending the performance of the proposed CONTRACT, including local conditions, uncertainty of weather, and all other contingencies. All designations and prices shall be fully and clearly set forth. The proper space in the bid and guaranty forms shall be suitably filled in.

Fill in all blanks on the bid form with non-erasable ink or type. Erasers or other changes must be explained or noted over the signature of the **BIDDER**.

The Bid Form may have a Contingency Allowance listed. Add this amount to the Base Bid to derive the Total Bid. The Contingency Allowance covers unforeseen conditions and shall not be used by the **BIDDER** without the written authorization of the **CITY**. At the conclusion of the project, the unused portion of the Contingency Allowance shall revert to the **CITY**.

Each bid must give the full business address of the **BIDDER** and must be signed by him with his usual signature. Bids by partnerships must furnish the full names of all partners and must be signed with the partnership name by one of the members of the partnership, or by an authorized representative, followed by the signature and designation of the person signing. Bids by corporations must be signed with the legal name of the corporation followed by the name of the State of Incorporation and by the signature and designation of the president, secretary, or other person authorized to bind it in the matter. The name of each person shall also be typed or printed below the signature. A bid by a person who affixes to this signature the word "president," "secretary," "agent," or other designation without disclosing his principal, may be held to be the bid of the individual signing. When requested by the **CITY** satisfactory evidence of the authority of the officer signing in behalf of the corporation shall be furnished.

Each project will be bid separately unless otherwise expressly requested in the CONTRACT document. Combination bids, that is bids on separate projects lumped together as a single bid or on all or none basis, will not be accepted unless the CONTRACT document expressly requests or permits same.

#### 1.12 **BID INELIGIBILITY**

Bids that contain irregularities of any kind may be declared unacceptable at the discretion of the **CITY**. The **CITY** may waive any irregularities and may reject any or all bids. Bids received after the deadline will be returned to the **BIDDER** unopened.

#### 1.13 **CONTRACT TIME**

The **BIDDER** agrees to provide all material, equipment, labor, and incidentals to conduct Resurfacing, Restoration and Rehabilitation (RRR), retrofitting, striping, marking, on street public parking, ADA sidewalk improvements, minimal drainage improvements and overall streetscape improvements for the block of Pine Street between Section Street and Bancroft Avenue in Fairhope's Central Business District, contained in the project Scope of Work. It is expected that the winning bidder can complete this project in sixty (60) calendar days, no exceptions for holidays following a fifteen (15) day Notice to Proceed Period.

#### 1.14 **INQUIRIES/ADDENDA**

**All Addenda are part of the CONTRACT Documents.** Include resultant costs in the Bid. Addenda will be issued by E-MAIL and posted on the City's website: [www.FairhopeAL.gov](http://www.FairhopeAL.gov). It is the responsibility of the **BIDDER** to verify that all Addenda have been received.

Questions or comments pertaining to this bid must be presented in writing, sent via email to [Purchasing@FairhopeAL.gov](mailto:Purchasing@FairhopeAL.gov) by Thursday, February 1, 2024, at 11:00 A.M. or will be forever waived.

#### 1.15 **BID ACCEPTANCE**

Bid with lowest Total Bid amount from a responsive and responsible **BIDDER** may be accepted if within the CONTRACT Budget. In the event that alternates are listed on the Bid Form, the lowest combination of Total Bid and Alternate Bids accepted by the **CITY** shall be the accepted bid. Alternates shall be awarded in the order in which they are listed on the Bid Form.

#### 1.16 **BIDDERS INTERESTED IN MORE THAN ONE BID**

If more than one bid is offered by any one party, by or in a name of his clerk, partner, corporation in which he has a substantial interest, or in which he is an officer, or other person, all such bids may be rejected. A party who has quoted prices on materials to a **BIDDER** is not thereby disqualified from quoting prices to other **BIDDERS** or from submitting a bid directly for the materials or work. The **CITY** reserves the right to determine in its discretion whether the provisions of this clause have been violated by any **BIDDER**.

#### 1.17 **ERRORS IN BIDS**

**BIDDERS** or their authorized agents are expected to examine the maps, drawings, specifications and all other instructions pertaining to the work, which will be open to their inspection. Failure to do so will be at the **BIDDER'S** own risk. In case of error, in the extension of prices, the unit price will govern.

#### 1.18 **CONTRACT AND BOND**

The **BIDDER** to whom award is made must, when requested, enter into written CONTRACT on the standard form as set out herein, with satisfactory security in the amount required, within the period specified, or, if no period be specified, within 15 days after the required forms are presented to him for signature.

#### 1.19 **COLLUSION**

If there is any reason for believing that collusion exists among the **BIDDERS** any or all bids may be rejected, and those participating in such collusion may be barred from submitting bids on the same or other work with the **CITY**.

## 1.20 **SUBLETTING OR ASSIGNING OF CONTRACT**

Limitations: The **CONTRACTOR** shall not sublet, assign, transfer, convey, sell, or otherwise dispose of any portion of the **CONTRACT**, his right, title or interest therein, or his power to execute such **CONTRACT**, to any person, firm or corporation without written consent of the **CITY**, and such written consent shall not be construed to relieve the **BIDDER** of any responsibility for the fulfillment of the **CONTRACT**. Unless otherwise stipulated in the proposal or special provisions, the **BIDDER** shall perform with his own organization, and with the assistance of workmen under his immediate superintendence and reported on his payroll, all **CONTRACT** work of a value not less than 50 percent of the total **CONTRACT** amount, except that any items designated in the **CONTRACT** as "Specialty Items" so performed by **SUB-CONTRACT** may be deducted from the total **CONTRACT** amount before computing the amount of work required to be performed by the **BIDDER** with his own organization.

### **SUB-CONTRACTOR'S** Status:

A **SUB-CONTRACTOR** shall be recognized only in the capacity of an employee or agent of the **CONTRACTOR** and the **CONTRACTOR** will be responsible to the **CITY** for all of the **SUB-CONTRACTOR's** work, including failures or omissions; and his removal may be required by the Project Manager, as in the case of an employee.

## 1.21 **PROSECUTION OF WORK**

The **BIDDER** shall prosecute the work continuously and diligently in the order and manner set out in his schedule as approved by the **CITY**. He shall provide sufficient satisfactory materials, labor, and equipment to ensure that the work will be completed in a satisfactory manner within the time specified in the **CONTRACT**.

Should the **BIDDERS** fail to maintain a satisfactory rate of progress, the **CITY** may require that additional forces and/or equipment be placed on the work to bring the project up to schedule and maintain it at that level.

Should the **BIDDER** fail to furnish sufficient satisfactory equipment and/or labor for maintaining the quality and progress of the work at satisfactory level, the **CITY** may withhold all estimates that may become due until satisfactory quality and progress are maintained; or the **CONTRACT** may be annulled.

**ITEM II  
SCOPE OF WORK**

**Bid No. 24-020-2024-PWI-001  
Pine Street One-Way Conversion and Parking Project  
Public Works Project No. 2024-PWI 001**

**SCOPE OF WORK**

The City of Fairhope is requesting responses from qualified contractors to provide all material, equipment, labor, and incidentals to conduct Resurfacing, Restoration and Rehabilitation (RRR), retrofitting (road diet and conversion to one-way traffic flow), striping, marking, on street public parking (using concrete paver system), ADA sidewalk improvements, minimal drainage improvements and overall streetscape improvements for the block of Pine Street between Section Street and Bancroft Avenue in Fairhope's Central Business District (CBD). It is expected that the winning bidder can complete this project in sixty (60) calendar days, no exceptions for holidays, following a fifteen (15) day Notice to Proceed Period.

The Project Scope of Work:

Entails all material, equipment, labor and incidentals to conduct Resurfacing, Restoration and Rehabilitation (RRR), retrofitting (road diet and conversion to one-way traffic flow), striping, marking, on street public parking (using concrete paver system), ADA sidewalk improvements, minimal drainage improvements and overall streetscape improvements for the block of Pine Street between Section Street and Bancroft Avenue in Fairhope's Central Business District (CBD).

Materials and workmanship shall be per the enclosed plans and specifications. This is a quantities-based project and all quantities will be field verified prior to payment. Bidding Contractors shall field-verify all conditions prior to submittal.

This project is to be bid with a base bid that includes all described improvements listed above including the paver public parking in Zone 1 (2400 SF) as shown in the plans. In addition, there will be an additive alternative bid for paver public parking in Zone 3 (1200 SF) as shown in the plans. This additive alternative will be awarded based on available project budget.

**Key Project Deliverables:**

- Pine Street narrowing (to 16' wide), milling and resurfacing from Section St. to Bancroft Avenue – approximately 266 L.F.
- Edge striping and markings – thermoplastic
- New 30-inch valley gutter on north margin of block – approximately 280 L.F.
- 2400 SF of new angled paver parking
- Drainage conveyance system to support the new parking
- New 8-foot wide concrete sidewalk along northside of ROW – approximately 258 L.F.
- Three new tree wells within the north sidewalk with cast iron tree well grates
- Completion of the sidewalk system (6-foot wide) along the south ROW – approximately 120 L.F.
- Street Lighting – to be performed by the City in coordination with the roadway/parking project
- Additive Alternative for additional 1200 SF of angled paver parking – Zone 3

**CRITICAL TIMELINES:**

- 15-day Notice to Proceed Period
- 60 Calendar Days allowed for work (no exceptions for holidays)
- Contractor is not limited to time of day or days of the week restrictions on this project – site available 24/7

**GENERAL NOTES:**

1. Contractor will be required to be Licensed (Appropriate GC), Bonded, and Insured. Documents will be required at time of bid/quote acceptance and/or issuance of purchase order.
2. Work must be completed 60 calendar days from the end of "Notice to Proceed" period.

3. Enclosed scope of work, descriptions, quantities, etc. are "good faith" estimates only. Prior to submitting bid/quotation, contractor should field measure and verify all quantities.
4. Bid Response will be treated and considered as "lump sum" bids for all described work.
5. Bid Responses are subject to the GENERAL CONDITIONS, SPECIAL PROVISIONS and SUPPLEMENTAL SPECIFICATIONS as attached.
6. LIQUIDATED DAMAGES: Liquidated Damages (LD's) shall be applied to this contract. The Liquidated Damages Daily Charge of \$250.00/calendar day will apply.
7. This is a sealed Public Works Bid Project – all applicable City and State terms and conditions apply.

## GENERAL CONDITIONS, SPECIAL PROVISIONS AND SUPPLEMENTAL SPECIFICATIONS

1. **SAFETY AND HEALTH REGULATIONS FOR CONSTRUCTION:** The Contractor shall comply with the Department of Labor Safety and Health Regulations for construction promulgated under the Occupational Safety and Health Act of 1970 (PL-596) and under Section 107 of the Contract Work Hours and Safety Standards Act (PL-91-54).

The Contractor alone shall be responsible for the safety, efficiency, and adequacy of his plant, appliances, and methods, and for any damage which may result from their failure or their improper construction, maintenance, or operations.

2. **DEPARTMENT OF TRANSPORTATION SPECIFICATIONS:** It is the intent of the City Engineer to construct within the described improvements in accordance with the State of Alabama Highway Department Standard Specifications for Highway Construction, most current edition. Said specifications shall be hereafter referred to as the Highway Department Specifications.

All provisions enumerated in the Highway Department Specifications shall be complied with, except as otherwise revised herein. Where certain modifications in said specifications appear in these specifications, only the modifications apply; otherwise, the standard specifications apply.

In said specifications where the words State of Alabama, Governor, State Highway Department, Director, etc., appear, substitute the Owner. Where the word Engineer appears, it shall mean City Engineer. Where the words Testing Laboratory and/or Laboratory appear, it shall mean the particular Testing Laboratory retained by the Owner for this work.

3. **DEPARTMENT OF TRANSPORTATION DRAWINGS:** Where State of Alabama Department of Transportation Alabama Standard Drawings are applicable for the work required, they shall be considered as part of the plans, and copies of required drawings will be afforded the Contractor for construction purposes.
4. **PROJECT SITE:** The Contractor shall keep the project site clean at all times. No loose dirt or stockpiles shall be left in areas other than those areas approved by the City Engineer. The City Engineer may require the Contractor to clean up any portion of the Project as he deems necessary.
5. **MATERIALS:** The Contractor agrees to comply with, and to require the compliance of all subcontractors with the provisions of Act #876 of the Legislature of Alabama, adopted on September 8, 1961, requiring purchase of materials and supplies and products for the project which are manufactured, mined, processed, or otherwise produced in the United States or its territories if the same are available at reasonable prices; and the Contractor further agrees and stipulates to pay to the Owner a sum to be determined and fixed by the Owner in an amount not less than five hundred (\$500.00) dollars nor more than twenty (20%) percent of the gross amount of the Contract in the event he or any subcontractor breach this agreement to use domestic products.
6. **EDGE OF PAVEMENT/SHOULDER PREPARATION:** This work shall include furnishing all labor, equipment, materials and all incidentals necessary to prepare the existing edge of pavement and shoulder to accept the wearing asphalt overlay. This work shall include adequate clipping and blading of the shoulder, patching of edge deformities and breakouts, and other work necessary to insure adequate structure is provided to support the new wearing asphalt surface. All prep work shall be a subsidiary obligation of the wearing asphalt unit price. Shoulder dressing and stabilization post paving will not be part of the work to be performed.
7. **PUBLIC CONVENIENCE:** No attempt is made to restrict work hours of the Contractor's operations, but he is reminded that it will be necessary to arrange his work schedule to provide the least inconvenience to the public and individual residents. The Contractor shall take extra precaution to insure that traffic is protected by the use of, but not limited to, flashing signs and barrels. No direct payment will be made for any of the work described in this section.
8. **EROSION CONTROL:** Immediately prior to any clearing and grubbing or any excavation which could disturb the soil, the Contractor shall install erosion control items in locations as required by the nature of the work performed.

The Contractor will be responsible for identifying and installing erosion control in areas where erosion may be encountered during construction of the project. The Contractor shall take all necessary precautions to ensure that the construction of the project and the erosion/sediment from the project are adequately controlled and do not damage streams or adjacent property.

The erosion control items installed shall be maintained by the Contractor throughout the course of the project. The City of Fairhope's Environmental Programs Manager shall be the final authority for corrective action, remediation, requirement of additional BMP's and all other directives required for erosion/sediment control.

It is the intent of this project that very little undisturbed portions of the ROW will be disturbed or left for any length of time in a disturbed state. No BMP plan is provided since the extents of construction are currently aggregate or asphalt and will be built in component phases. Special care should be taken when the aggregate areas are being retrofitted to concrete unit pavers. Excavated areas should be backfilled on the same day and excavation should not take place in advance of inclement weather. The Bidder shall provide a lump sum price to provide for and maintain minimal BMP's.

In no case shall the BMP Lump Sum Cost be greater than 2.5% of the Base Bid Cost. Bid Tabulations will be corrected to reflect a maximum LS Bid based on 2.5%. If no BMP's are required or directed to be deployed, no payment will be made on that line item.

9. **TEMPORARY TRAFFIC CONTROL:** The awarded Contractor shall be responsible for TTC during the entirety of the project. Once mobilized the Contractor shall be allowed to convert the block to one-way traffic to allow ample working room for sidewalks and paver parking. In addition, full street closures will be considered and allowed on a limited basis. The contractor shall provide all necessary cones, barrels, barricades, signage and other TTC appurtenances necessary to facilitate access and assure a safe work zone.

The Contractor shall provide a TTC Plan at the preconstruction meeting for approval by the City. In no case shall the TTC Lump Sum Cost be greater than 5% of the Base Bid Cost. Bid Tabulations will be corrected to reflect a maximum LS Bid based on 5%.

10. **UNDERGROUND UTILITIES AND SERVICES:** Existing utilities, mailboxes, signs, and minor obstructions are not shown on the plans. Their presence, and the required removal and the resetting thereof shall be considered incidental to the overall project and the cost for the work noted above shall be included in the overall "lump sum" price for the project (no separate payment).

The Contractor is solely responsible for the locating all existing Utilities and Services. Failure of the Contractor to locate any utility does not justify additional payment to the Contractor if said utility is damaged. The Contractor must notify the utility companies involved prior to starting construction and shall make every effort not to damage any utilities. If utilities are damaged by the Contractor, the Contractor must pay all expenses incurred in the repair at no cost to the Owner or his representatives.

11. **STREETLAMPS:** IT is the intent of the City to install street lighting as an amenity to this renewed streetscape. This contract does not include street lighting material or installation. However, the following applies:
- a. CONTRACTOR SHALL PROVIDE 3 – 24" X 24" BLOCK OUTS WITHIN THE NEW SIDEWALK AS SHOWN IN PLANS.
  - b. CITY ELECTRIC DEPARTMENT WILL RUN ALL CONDUITS PRIOR TO CONTRACTOR'S PLACEMENT OF SIDEWALK.
  - c. CITY ELECTRIC DEPARTMENT WILL PROVIDE AND INSTALL NEW STREET LAMPS.
  - d. CONTRACTOR SHALL BE RESPONSIBLE FOR COORDINATING ALL WORK TO AVOID CONFLICTS.

12. **PROVISIONS REQUIRED BY LAW DEEMED INSERTED:** Each and every provision of law and clause required by law to be inserted in this contract shall be deemed to be inserted herein and the contract shall be read and enforced as though it were included herein, and if through mistake or otherwise any such provision is not inserted, or is not correctly inserted, then upon the application of either party the contract shall forthwith be physically amended to make such insertion or correction.

13. **PROTECTION OF LIVES AND HEALTH:** "The Contractor shall exercise proper precaution at all times for the protection of persons and property and shall be responsible for all damages to persons or property, either on or off the site, which occur as a result of his prosecution of the work. The safety provisions of applicable laws and building and construction codes, in addition to specific safety and health regulations described by Chapter XIII, Bureau of Labor Standards, Department of Labor, Part 1518, Safety and Health Regulations for Construction, as outlined in the Federal Register, Volume 36, No. 75, Saturday, April 17, 1971. Title 29 - LABOR, shall be observed and the Contractor shall take or cause to be taken, such additional safety and health measures as the Contracting Authority may determine to be reasonably necessary."

14. **CITY ENGINEER'S AUTHORITY:** The City Engineer shall give all orders and directions contemplated under this contract and specifications, relative to the execution of the work. The City Engineer shall determine the amount,

quality, acceptability, and fitness of the several kinds of work and materials which are to be paid for under this contract and shall decide all questions which may arise in relation to said work and the construction thereof. The City Engineer's estimates and decisions shall be final and conclusive, except as herein otherwise expressly provided. In case any question shall arise between the parties hereto relative to said contract or specifications, the determination or decision of the City Engineer's shall be a condition precedent to the right of the Contractor to receive any money or payment for work under this contract affected in any manner or to any extent by such question.

The City Engineer shall decide the meaning and intent of any portion of the specifications and of any plans or drawings where the same may be found obscure or be in dispute. Any differences or conflicts in regard to their work which may arise between the Contractor under this contract and other Contractors performing work for the Owner shall be adjusted and determined by the City Engineer.

15. **USE OF PREMISES AND REMOVAL OF DEBRIS:** The Contractor expressly undertakes at this own expense:
- a. To take every precaution against injuries to persons or damage to property.
  - b. To store his apparatus, materials, supplies and equipment in such an orderly fashion at this site of the work as will not unduly interfere with the progress of his work or the work of any other contractors.
  - c. To place upon the work or any part thereof only such loads as are consistent with the safety of that portion of the work; materials, and debris caused by his operations, to the end that at all times the site of the work shall present a neat, orderly and workmanlike appearance.
  - d. Before final payment to remove all surplus material, false-work, temporary structures, including foundations thereof, plant of any description and debris of every nature resulting from his operations, and to put the site in a neat, orderly condition.
  - e. To effect all cutting, fitting or patching of his work required to make the same to conform to the plans and specifications and, except with the consent of the City Engineer, not to cut or otherwise alter the work of any other Contractor.
16. **INSURANCE:** The Contractor shall not commence work under this contract until he has obtained all the insurance required by the City of Fairhope (see contract documents) and such insurance has been approved by the Owner, nor shall the Contractor allow any subcontractor to commence work on his subcontract until the insurance required of the subcontractor has been so obtained and approved.
17. **MATERIALS, SERVICE AND FACILITIES:**
- a. It is understood that except as otherwise specifically stated in the Contract Documents, the Contractor shall provide and pay for all materials, labor, tools, equipment, water, light, power, transportation, supervision, temporary construction of every nature, and all other services and facilities of every nature whatsoever necessary to execute, complete and deliver the work within the specified time.
  - b. Any work necessary to be performed after regular working hours, on Sundays or Legal Holidays, shall be performed without additional expense to the Owner.
18. **CONTRACTOR'S TITLE TO MATERIALS:** No materials or supplies for the work shall be purchased by the Contractor or by any Subcontractor subject to any chattel mortgage or under a conditional sale contract or other agreement by which an interest is retained by the seller. The Contractor warrants that he has good title to all materials and supplies used by him in the work, free from all liens, claims or encumbrances.
19. **INSPECTION AND TESTING OF MATERIALS:**
- a. All materials and equipment used in the construction of the project shall be subject to adequate inspection and testing in accordance with accepted standards. The laboratory or inspection agency shall be selected by the Owner. The Owner will pay for all laboratory inspection service direct, and not as a part of the contract.
  - b. Materials of construction, particularly those upon which the strength and durability of the structure may depend, shall be subject to inspection and testing to establish conformance with specification and suitability for uses intended.
20. **MATERIAL SPECIFICATIONS:**
- a. Brand Name or Equivalent: The following Material Specifications shall be interpreted as a minimum standard of quality and all be associated with or equivalent. Brand Name or Equivalent Specification means a specification limited to one or more items by manufacturers' names or model numbers to describe the standard of quality, performance, and other salient characteristics needed to meet the City requirements, and which provides for the submission of equivalent



products. If the Contractor opts to propose an equivalent brand, product, material or source outside this specification, then a submittal will be required.

- b. A submittal refers to the written and/or physical information provided by a responsible contractor (i.e., contractors and subs) to the general contractor. This information is submitted to the Project Manager for approval of equipment, materials, etc. before they are fabricated and delivered to the project. Submittals can be presented in various formats, such as shop drawings, cut sheets on equipment, and material samples. Submittals are required primarily for the design team to verify that the correct products and quantities will be installed on the project in compliance with the design documents/contract documents.
- c. Submittals are mandatory for all items specified that the Contractor is asserting is "equivalent". Submittals shall be submitted electronically to Richard D. Johnson, PE, Project Engineer, at [richard.johnson@fairhopeal.gov](mailto:richard.johnson@fairhopeal.gov) – submittals will be reviewed and either approved, denied or requested for more information within three working days. For items used that meet exact specifications, contractor shall retain all invoices, packing slips, spec sheets, cut sheets and receipts to provide copies monthly, upon request and/or at project closeout in the form of a material/product spec/warranty/user's manual three-ring binder.
- d. DRAINAGE:
  - Upstream Drainage Inlet/Box – NDS 18" One Piece Catch Basin with 2 Openings (1882)
  - Upstream Drainage Inlet Grate – NDS 18" x 18" CAST IRON SQUARE GRATE (1813)
  - Drainpipe – 8" Diameter HDPE – ADS N-12® ST IB PIPE (ASTM F2648)  
SPECIFICATION
  - Downstream Outlet Grate & Frame – Neenah Heavy Duty Concave Inlet Frame, Grate (Type K) (R-3205)
- e. TREE WELLS:
  - Tree Grate and Frame – Neenah Foundry R-8814-A
- f. Concrete Pavers System – See Supplemental Section 23

**21. CONTRACT TIME:** Contract time for PINE STREET ONE-WAY CONVERSION & PARKING PROJECT City of Fairhope Public Works Project No. 2024-PWI 001 shall be **SIXTY (60) calendar days**. Contract time shall start fifteen (15) days following the Official Notice to Proceed.

**22. LIQUIDATED DAMAGES (LD's):** Liquidated Damages (LD's) shall apply. LD's shall be calculated at a fixed rate of \$250.00 per calendar day beyond the designated contract time.

Supplemental SECTION 23 – INTERLOCKING CONCRETE UNIT PAVING ON AGGREGATE BASE

PART 1 - GENERAL

1.1 SUMMARY

A. Section Includes

1. Work consists of furnishing and installing a Concrete Paving Slab System in accordance with these specifications and in general conformance with the lines, grades, design, and dimensions shown on the plans.
2. Installation work includes:
  - a. Verifying subgrade elevations and slopes generally conform to the lines, grades and site conditions depicted in the construction documents;
  - b. Furnishing and installing geotextile (where required), base course, bedding course, edge restraint, concrete slabs and joint filling sand as shown on the construction drawings.

B. Related Requirements:

1. Work Relating to Earth Moving
2. Work Relating to Geotextiles for Earthwork
3. Work Relating to Aggregate Base Courses
4. Work Relating to Curbs and Gutters

1.2 REFERENCES

A. American Society for Testing and Materials (ASTM)

1. ASTM C33 Standard Specification for Concrete Aggregates
2. ASTM C94 Standard Specification for Ready-Mixed Concrete
3. ASTM C131 Resistance to Degradation of Small-Sized Course Aggregate by Abrasion and Impact in the Los Angeles Machine
4. ASTM C136 Sieve Analysis of Fine and Coarse-Grained Aggregates
5. ASTM C140 Sampling and Testing Concrete Masonry Units and Related Units
6. ASTM C144 Aggregate for Masonry Mortar
7. ASTM C979 Pigments for Integrally Colored Concrete
8. ASTM C1782 Standard Specification for Segmental Concrete Paving Slabs
9. ASTM D698 Laboratory Compaction Characteristics of Soil Using Standard Effort
10. ASTM D2488 Description and Identification of Soils (Visual-Manual Procedure)
11. ASTM D2940 Graded Aggregate Material for Bases or Subbases for Highways or Airports
12. ASTM D4873 Identification, Storage, and Handling of Geosynthetic Rolls and Samples

B. American Association of State Highway and Transportation Officials (AASHTO):

1. AASHTO M288 Geotextile Specification for Highway Applications

### 1.3 SUBMITTALS

- A. Contractor shall submit to the owner for approval a minimum of one full-size sample of each concrete paving slab for type, size, and thickness. Color and finish shall be approved using the mockup described in Section 1.4. The samples shall represent the range of shape, texture, and color permitted for the respective type. Color(s) will be selected by Architect/Engineer/Landscape Architect/Owner from Manufacturer's standard colors.
- B. Prior to delivery of the associated material to the site, the Contractor shall submit the following product-specific documentation for approval:
  - 1. Aggregates
    - a. Sieve analysis per ASTM C136 for subbase, base, bedding and joint aggregate materials
    - b. Minimum 3 lb. sample of each material for independent testing.
  - 2. Concrete Paving Slabs:
    - a. Test results from an independent testing laboratory for compliance with ASTM C1782.
    - b. Manufacturer's catalog product data.
    - c. Safety Data Sheets (SDS).
  - 3. Geotextile
    - a. One 18-inch x 18-inch panel of each type of geotextile to be used for inspection and testing. The sample panels shall be uniformly rolled and shall be wrapped in plastic to protect the material from moisture and damage during shipment. Samples shall be externally tagged for easy identification. External identification shall include the name of the manufacturer; product type; product grade; lot number; and physical dimensions.
    - b. Current National Transportation Product Evaluation Program (NTPEP) evaluation report.
    - c. Safety Data Sheets (SDS).

### 1.4 QUALITY ASSURANCE

- A. Contractor Qualifications:
  - 1. Contractor and/or subcontractor be qualified by experience to perform such installation of Concrete Paving Slab System as shown in the attached drawings. Contractor and/or subcontractor shall be able to provide, upon request, list of five (5) previously constructed projects of similar size and magnitude prior to the award of contract to be qualified. Contact names, telephone numbers, and date of completion shall be listed for each project.
  - 2. Contractor shall conform to all local, state/provincial licensing and bonding requirements.
- B. Mockups (This section may be waived if Contractor can provide a site visit of a previous project demonstrating such work): Build mockups to verify selections made under submittals, to demonstrate aesthetic effects, and to set quality standards for materials and execution.
  - 1. Install a 10 ft x 10 ft slab area following the installation practices described in Section 3.4. This area shall be used to verify joint sizes; lines; laying pattern(s); color(s); and, texture of the job.
  - 2. To provide a proper representation of color blend, blending during installation of sample mock-up will be pulled from a minimum of 3 cubes.
  - 3. This area shall be the standard by which the work will be judged.

4. Subject to approval by the Owner, the mock-up may be retained as part of the finished work. If mock-up is not retained, remove and dispose of mock-up at the completion of the project.

#### 1.5 DELIVERY, STORAGE, AND HANDLING

- A. Contractor shall coordinate delivery and paving schedule to minimize interference with normal use of buildings adjacent to paving.
- B. Contractor shall check all materials upon delivery to assure that the proper materials have been received and are in good condition before signing off on the manufacturer's packing slip.
- C. Contractor shall protect all materials from damage or contamination due to job site conditions and in accordance with manufacturer's recommendations. Damaged or contaminated materials shall not be incorporated into the work.
- D. Concrete paving slabs shall be delivered to the site in steel banded, plastic banded, or plastic wrapped cubes capable of transfer by forklift or clamp lift. Unload and store concrete slabs at the job site in such a manner that no damage occurs to the product.
- E. Contractor shall handle and transport aggregates to avoid segregation, contamination, and degradation and keep different materials sufficiently separated as to prevent mixing. The material shall not be dumped or stored one material on top of another unless it is part of the installation process. Materials shall be covered to prevent removal by wind.
- F. Geotextile shall be delivered, stored and handled in accordance with ASTM D4873.

#### 1.6 ENVIRONMENTAL CONDITIONS

- A. Slabs shall not be installed during heavy rain, freezing conditions or snowfall.
- B. Base course shall not be installed on frozen soil subgrade.
- C. Slabs, bedding sand, and joint filling sand shall not be installed on frozen aggregates.

#### 1.7 MAINTENANCE MATERIALS

- A. Provide 100 square feet additional slab material for use by Owner for maintenance and repair.
- B. Store extra slab materials in Owner-designated location.

### PART 2 - PRODUCTS

#### 2.1 CONCRETE PAVING SLABS

- A. Concrete Paving Slabs Basis-of-Design:

1. Slab Name: **Belgard Commercial Concrete Paver, Holland Stone**
  - a. Shape: **4x8”**
  - b. Thickness: **3-1/8” [80 mm]**
  - c. Color: **Fairhope Red**
  - d. Finish: **Standard (Smooth)**  
Supplier: **SiteOne Landscape Supply, an Oldcastle Vendor; 26264 Public Works Rd.; Daphne, AL 36526-9131**
  - e. Contact: **Christopher Wilson; 850-527-1724; [CWilson@siteone.com](mailto:CWilson@siteone.com)**
  - f. Substitutions: Equivalent paver system will be considered, any proposed equivalent paver shall be reviewed and approved by addendum prior to bid opening.

- B. Slabs shall meet the following material and physical properties set forth in ASTM C 1782:
  1. Measured length or width of test specimens shall not differ by more than - 0.04 in and +0.06 for unit up to 24 in and -.06 and +0.12 for units over 24 in. Measured thickness shall not differ by more than +/- 0.12 in.
  2. Average Modulus of Rupture (flexural strength) of not less than 725 psi (5.0 MPa) with no individual unit under 650 psi (4.5 MPa) when tested in accordance with ASTM C1782.
  3. Freeze-thaw durable as tested in accordance with ASTM C1645. The average mass loss of all specimens tested shall not be greater than (a) 225 g/m<sup>2</sup> when subject to 28 freeze-thaw cycles, or (b) 500 g/m<sup>2</sup> when subject to 49 freeze-thaw cycles.
  4. Pigment in Concrete Slabs shall conform to ASTM C979.
- C. Efflorescence shall not be a cause for rejection.

## 2.2 BEDDING SAND

- A. Bedding sand shall be clean, non-plastic sand, free from deleterious or foreign matter, and manufactured from crushed rock.
- B. Screenings or stone dust shall not be utilized.
- C. Verify gradation conforms to ASTM C33 requirements for concrete sand (listed in Table 1) as tested in accordance with ASTM C136.

Table 1  
Gradation Requirements for Bedding Sand

<u>Sieve Size</u>	<u>Percent Passing</u>
3/8 inch (9.5 mm)	100
No. 4 (4.75 mm)	95 to 100
No. 8 (2.36 mm)	85 to 100
No. 16 (1.18 mm)	50 to 85
No. 30 (0.600 mm)	25 to 60
No. 50 (0.300 mm)	5 to 30
No. 100 (0.150 mm)	0 to 10
No. 200 (0.075 mm)	0 to 1

2.3 JOINT FILLING SAND

- A. Joint filling sand aggregate shall be clean, non-plastic sand, free from deleterious or foreign matter, and manufactured from crushed rock.
- B. Screenings or stone dust shall not be utilized.
- C. Verify gradation conforms to ASTM C144 requirements for concrete sand (listed in Table 2) as tested in accordance with ASTM C136.

Table 2  
Gradation Requirements for Joint Filling Sand

<u>Sieve Size</u>	<u>Percent Passing</u>
No. 4 (4.75 mm)	100
No. 8 (2.36 mm)	95 to 100
No. 16 (1.18 mm)	70 to 100
No. 30 (0.600 mm)	40 to 100
No. 50 (0.300 mm)	10 to 35
No. 100 (0.150 mm)	2 to 15
No. 200 (0.075 mm)	0 to 5

2.4 BASE COURSE

- A. Base aggregate shall be clean, non-plastic, free from deleterious or foreign matter, recycled concrete, and manufactured from crushed rock.
- B. Verify gradation conforms to ASTM D2940 as presented in Table 3.

Table 3  
Gradation Requirements for Base Course Material

<u>Sieve Size</u>	<u>Percent Passing</u>
2 in (50 mm)	100
1 ½ in (37.5 mm)	95 to 100
¾ in (19 mm)	70 to 92
3/8 in (9.5 mm)	50 to 70
No. 4 (4.75 mm)	35 to 55
No. 30 (0.600 mm)	12 to 25
No. 200 (0.075 mm)	0 to 8

2.5 EDGE RESTRAINTS

- A. Cast-in-place edge restraints in general conformance with the specifications and dimensions in the construction documents.
- B. Precast concrete or cut stone in general conformance with the specifications and dimensions in the construction documents.

- C. Aluminum or steel edging in general conformance with the specifications and dimensions in the construction documents (pedestrian-only applications).

## 2.6 GEOTEXTILES

- A. Geotextile materials shall be selected by the Design Engineer based on the intended use in accordance with AASHTO M288.
- B. Only geotextiles with a current NTPEP evaluation will be accepted.

## PART 3 - EXECUTION

### 3.1 PREPARATION

- A. Prior to commencement of any work, the Contractor shall conduct a pre-construction meeting with the Owner, Designer, and affected sub-trades. The pre-construction meeting should establish contractor responsibilities and at a minimum verify:
  1. The location of the mock-up, and whether it will be part of the final construction or need to be removed.
  2. The site layout is in general conformance with the construction documents.
  3. The subgrade lines and elevations meet the requirements of the construction documents. The subgrade elevations shall be within +/- 0.1 ft of the specified grades.
  4. Subgrade soil conditions and grades meet the requirements in the construction documents.
  5. The details of the site's erosion and sediment control plan.
- B. Compaction of the soil subgrade is recommended to at least 98% Standard Proctor Density per ASTM D698 for pedestrian areas, walkways, plazas and residential driveways. Compaction to at least 98% Stabilization of the subgrade and/or base material, or addition of an impermeable layer, may be necessary with weak, saturated or expansive subgrade soils.
- C. Proof-roll prepared subgrade according to requirements in Section 31 20 00 Earth Moving to identify soft pockets and areas of excess yielding. Proceed with subbase installation only after deficient subgrades have been corrected.
- D. Once the Contractor has confirmed the subgrade conditions are in general conformance with the requirements in the construction documents, the Contractor shall begin installing the base course material. By initiating installation of the base course, the Contractor acknowledges acceptance of the subgrade.

### 3.2 INSTALLATION OF BASE COURSE

- A. Install Geotextiles as required in accordance with the construction documents. The Geotextile is applied to the bottom and sides of the excavation with overlapping joints a minimum of **18 inches**. Overlaps to follow downslope.
- B. Install the base course at the thickness, compaction, surface tolerances, and elevations outlined in the construction documents.

1. The aggregate should be spread and compacted in uniform layers not exceeding 6-inch loose thickness.
  2. Compact base course to 98% Standard Proctor Density in accordance with ASTM D698.
  3. Density testing shall be conducted to verify conformance.
  4. Surface tolerance should be plus or minus 3/8 inch (10 mm) over a 10-foot. (3 m) straight edge laid in any direction.
  5. Base course compaction must be achieved near curbs, grade beams, concrete collars around utility structures, lights standards, tree wells, building edges, and other protrusions as applicable to the project. In areas not accessible to large compaction equipment, compact to specified density with mechanical tampers (e.g. jumping jacks).
  6. The upper surface of the base shall be sufficiently well graded and compacted to prevent infiltration of the bedding sand into the base during construction and throughout its service life. Segregated areas of the granular base shall be blended by the application of crushed fines that have been watered and compacted into the surface.
- C. Before commencing the placing of the bedding sand, the base course shall be inspected by the Owner or the Consultant, confirming the base course is in compliance with the construction documents.

### 3.3 INSTALLATION OF EDGE RESTRAINTS

- A. Adequate edge restraint shall be provided along the perimeter of all paving as specified. The face of the edge restraint, where it abuts slabs, shall be vertical.
- B. All concrete edge restraints shall be constructed to dimensions and grades in general conformance with the construction documents and shall be supported on a compacted base not less than 6 inches thick. Concrete curbs shall meet local requirements or the requirements of Section 32 16 13 - Curbs and Gutters, whichever is more restrictive. All concrete shall be in accordance with ASTM C94 requirements.

### 3.4 INSTALLATION OF BEDDING SAND, SLABS, AND JOINT FILLING MATERIAL

- A. Spread the bedding sand evenly over the base course and screed to a nominal 1-inch (25 mm) thickness. The Contractor shall screed the bedding sand using an approved mechanical spreader or by screed rails and boards. The screeded sand should not be disturbed. Place sufficient sand to stay ahead of the laid slabs. Do not use the bedding sand to fill depressions in the base course surface.
- B. Ensure that concrete paving slabs are free of foreign material before installation. Concrete slabs shall be inspected for color distribution and all chipped, damaged, or discolored concrete slabs shall be replaced. Initiation of concrete slabs placement shall be deemed to represent acceptance of the slabs.
- C. Lay the concrete paving slabs in the pattern(s) shown on the drawings. Maintain straight pattern lines.
- D. Paving slab units shall be installed from a minimum of 3 bundles simultaneously to ensure color blending.



- E. Joints between the individual concrete paving slabs, and between slabs and the edge restraints, buildings, collars, or other protrusions/edging, shall be between 1 /16 inch and 3 /16 inch (2 mm to 5 mm) wide.
- F. Joint (bond) lines shall not deviate more than  $\pm 1/2$  in. ( $\pm 15$  mm) over 50 ft. (15 m) from string lines.
- G. When a section of a paving slab must be cut and the cut area is less than 25% of the total slab area, there is no need to include additional cuts to reduce the risk of a cracked unit. If more than 25% of a paving slab must be cut and removed, consideration must be given to installing additional cuts to reduce the risk of cracking under loads. Cut all slabs using a masonry saw. Upon completion of cutting, the area must be swept clean of all debris to facilitate inspection and to ensure the concrete slabs are not damaged during compaction.
- H. The slabs shall be hand tamped or compacted with equipment designed for use on slabs to achieve a leveled surface.
- I. Any units that are structurally damaged during installation shall be immediately removed and replaced.
- J. Sweep dry joint filling sand into the joints and vibrate with a roller compactor with a minimum of two passes until they are full. Do not compact within 3 feet (1 m) of the unrestrained edges of the paving slab units.
- K. All work to within 3 feet (1 m) of the laying face must be left fully compacted with sand-filled joints at the end of each day.
- L. Sweep off excess sand when the job is complete.
- M. The final surface elevations shall not deviate more than 3/8 inch (10 mm) under a 10-foot (3 m) long straightedge.
- N. Surface elevation of slabs shall be 1/8-inch to 1/4-inch (3 mm to 6 mm) above adjacent rigid surfaces, including drainage inlets, concrete collars or gutters, sidewalks, etc.

### 3.5 AS-BUILT CONSTRUCTION TOLERANCES

- A. Final inspection shall be conducted to verify conformance to the drawings after removal of excess joint sand. All pavements shall be finished to lines and levels to ensure positive drainage at all drainage outlets and channels.
- B. The final surface elevations shall not deviate more than  $\pm 3/8$  inch (10 mm) under a 10-foot long straight edge.
- C. Lippage: No greater than 1/8 in. (3 mm) difference in height between adjacent slabs.

END OF SECTION 23

## 18" ONE PIECE CATCH BASIN

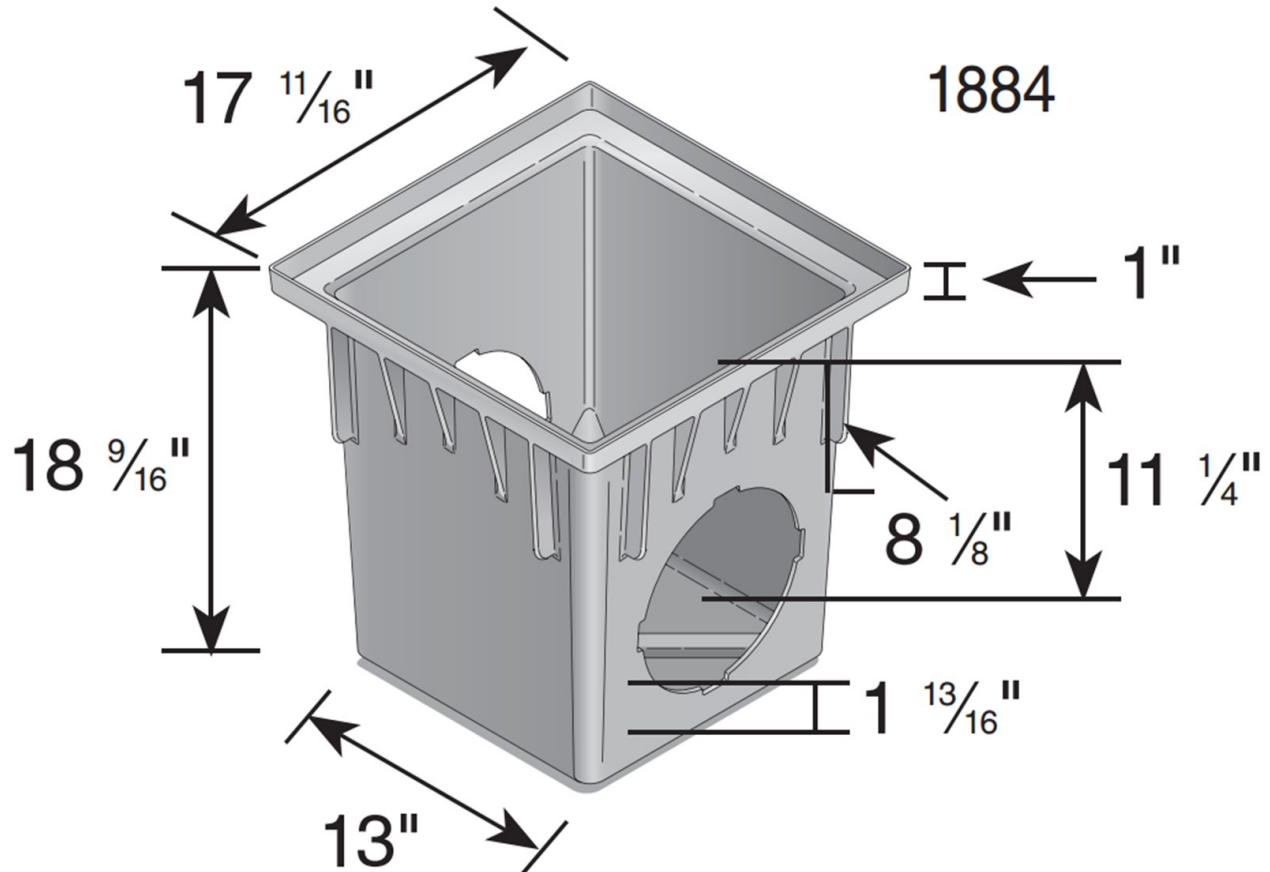

Material: UV Protected High Density Polyethylene (HDPE)

Weight: 9.65 lbs

Colors: Black

- 18" One Piece Catch Basin with 2 Openings (1882)  
Includes 2 #1890 Reducer Rings
- 18" One Piece Catch Basin with 4 Openings (1884)  
Includes 4 #1890 Reducer Rings

Requires either #1206, #1242, #1245, #1266, #1888, or #1889 universal outlet to connect pipe

Supplied By:

**TRENCHDRAIN  
SUPPLY**

877-903-7246  
www.trenchdrainsupply.com

## 18" x 18" CAST IRON SQUARE GRATE

Part #: 1813  
 Material: Cast Iron  
 Color: Black  
 Fits: Catch Basin #1882, #1884, #1800, #1804,  
 #1816, #1830 and #1840.  
 Grate Opening: 1" x 3"  
 Open Surface Area: 100.63 Sq. Inches  
 Head Pressure / Flow Rate:  
 Head ( inches) - Max Flow  
 1" = 478.92 GPM  
 1/2" = 338.65 GPM  
 H-20 Load Rating  
 Weight Each: 46 lbs.

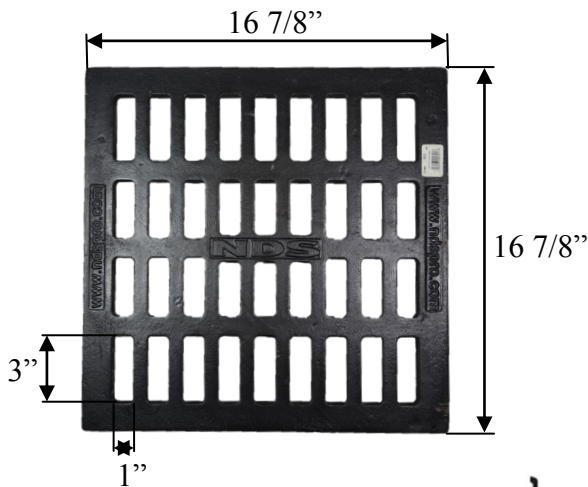
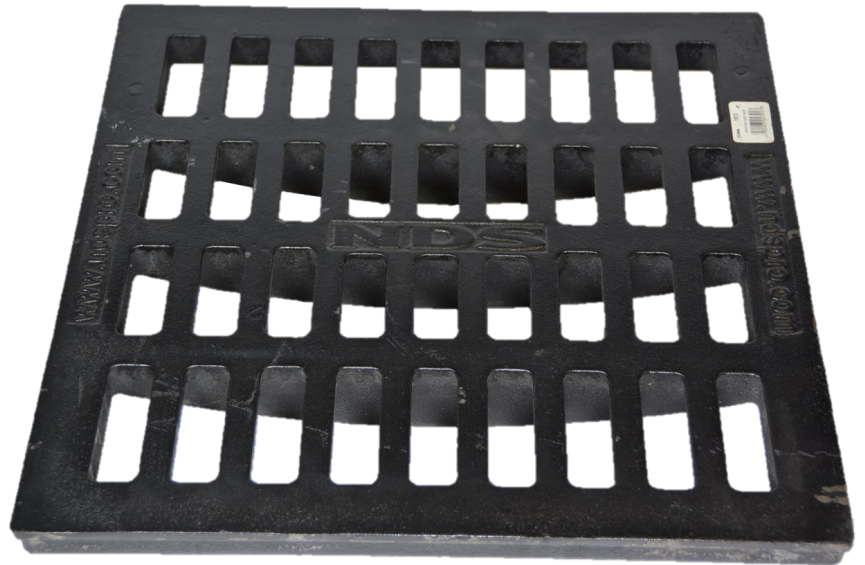

### Class C

- Loads of 176-325 psi.
- Recommended for heavy-duty pneumatic tire forklifts and tractor trailers at speeds less than 20 m.p.h., H-20 rated.

Supplied By:

## ADS N-12® ST IB PIPE (ASTM F2648) SPECIFICATION

### Scope

This specification describes 4- through 60-inch (100 to 1500 mm) ADS N-12 ST IB pipe (per ASTM F2648) for use in gravity-flow land drainage applications.

### Pipe Requirements

ADS N-12 ST IB pipe (per ASTM F2648) shall have a smooth interior and annular exterior corrugations.

- 4- through 60-inch (100 to 1500 mm) pipe shall meet ASTM F2648.
- Manning’s “n” value for use in design shall be 0.012.

### Joint Performance

Pipe shall be joined using a bell & spigot joint meeting ASTM F2648. The joint shall be soil-tight and gaskets for diameters 12- through 60-inch, shall meet the requirements of ASTM F477. For diameters 4- through 10-inch, the joint shall be soil-tight using an engaging dimple connection. Gaskets shall be installed by the pipe manufacturer and covered with a removable, protective wrap to ensure the gasket is free from debris. A joint lubricant available from the manufacturer shall be used on the gasket and bell during assembly.

### Fittings

Fittings shall conform to ASTM F2306. Bell and spigot connections shall utilize a welded bell and valley or saddle gasket meeting the soil-tight joint performance requirements of ASTM F2306.

### Material Properties

Material for pipe production shall be an engineered compound of virgin and recycled high density polyethylene conforming with the minimum requirements of cell classification 424420C (ESCR Test Condition B) for 4- through 10-inch (100 to 250 mm) diameters, and 435420C (ESCR Test Condition B) for 12- through 60-inch (300 to 1500 mm) diameters, as defined and described in the latest version of ASTM D3350, except that carbon black content should not exceed 4%. The design engineer shall verify compatibility with overall system including structural, hydraulic, material, and installation requirements for a given application.

### Installation

Installation shall be in accordance with ASTM D2321 and ADS recommended installation guidelines, with the exception that minimum cover in trafficked areas for 4- through 48-inch (100 to 1200 mm) diameters shall be one foot. (0.3 m) and for 60-inch (1500 mm) diameter the minimum cover shall be 2 ft. (0.6 m) in single run applications. Backfill for minimum cover situations shall consist of Class 1 (compacted) or Class 2 (minimum 90% SPD) material. Maximum fill heights depend on embedment material and compaction level; please refer to Technical Note 2.02. Contact your local ADS representative or visit our website at [www.ads-pipe.com](http://www.ads-pipe.com) for a copy of the latest installation guidelines.

### Pipe Dimensions

	Nominal Diameter, in (mm)												
Pipe I.D. in (mm)	4 (100)	6 (150)	8 (200)	10 (250)	12 (300)	15 (375)	18 (450)	24 (600)	30 (750)	36 (900)	42 (1050)	48 (1200)	60 (1500)
Pipe O.D.* in (mm)	4.8 (122)	6.9 (175)	9.1 (231)	11.4 (290)	14.5 (368)	18 (457)	22 (559)	28 (711)	36 (914)	42 (1067)	48 (1219)	54 (1372)	67 (1702)

\*Pipe O.D. values are provided for reference purposes only, values stated for 12 through 60-inch are ±1 inch. Contact a sales representative for exact values

\*\*All diameters available with or without perforations.

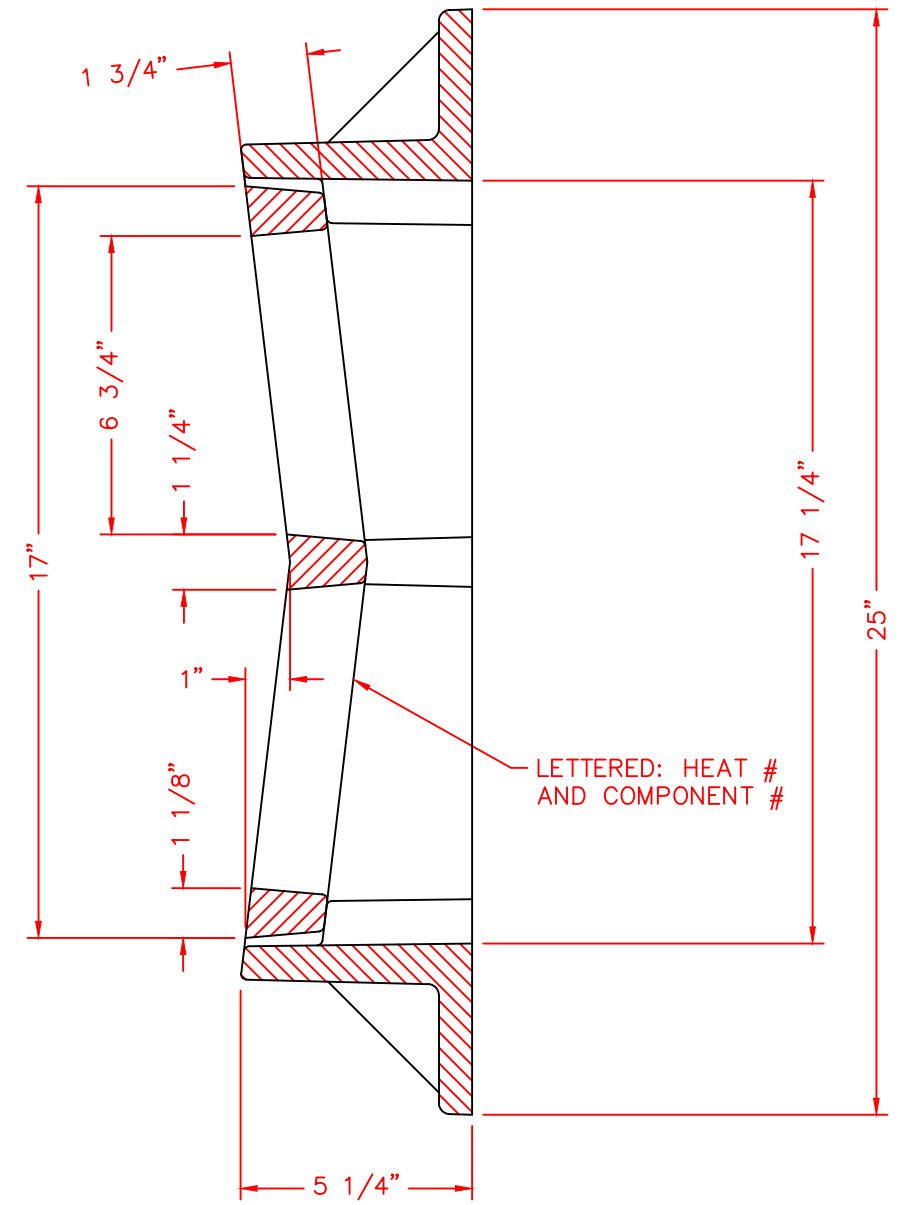
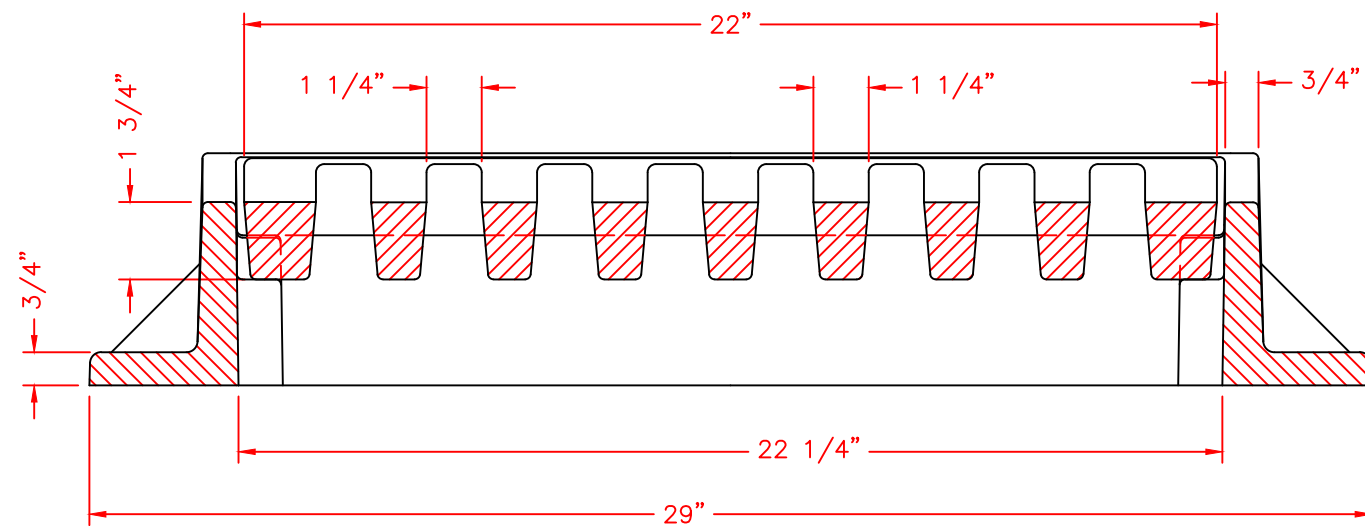
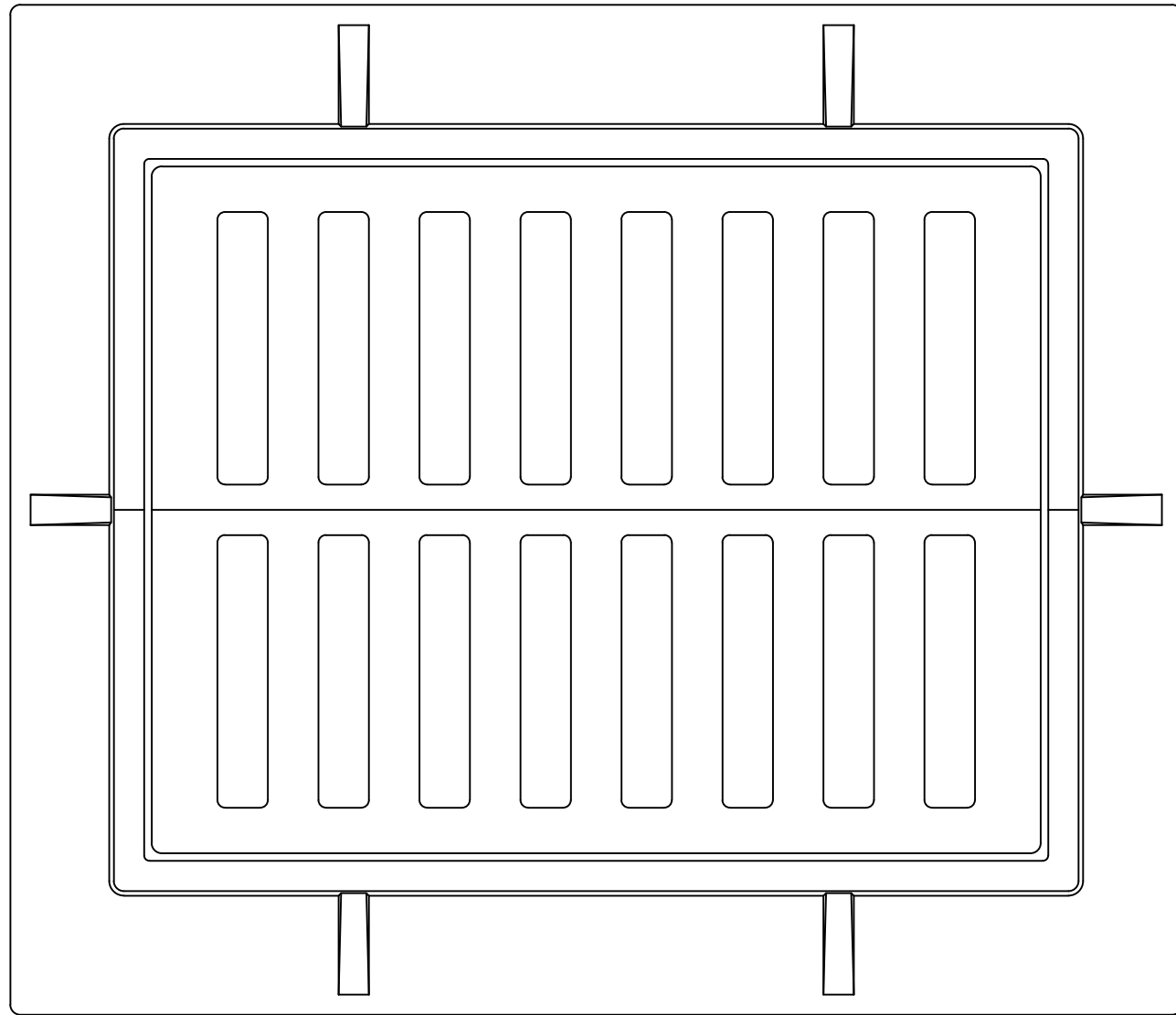

COMPONENT NO'S: FRAME 3205-0001, GRATE 3205-0002  
 MATERIAL: CAST GRAY IRON ASTM A-48, CLASS 35B  
 FINISH: NO PAINT  
 WEIGHT: FRAME 151 LBS., GRATE 97 LBS.

DR. E. REMME	SCALE 1/4"=1"	TITLE: R-3205
CH.	DIM CHK.	FRAME AND TYPE "A" CONCAVE GRATE
APP.	NEENAH FOUNDRY COMPANY	NF-3205 400B
DATE 02-09-2009	NEENAH WISCONSIN 54956	



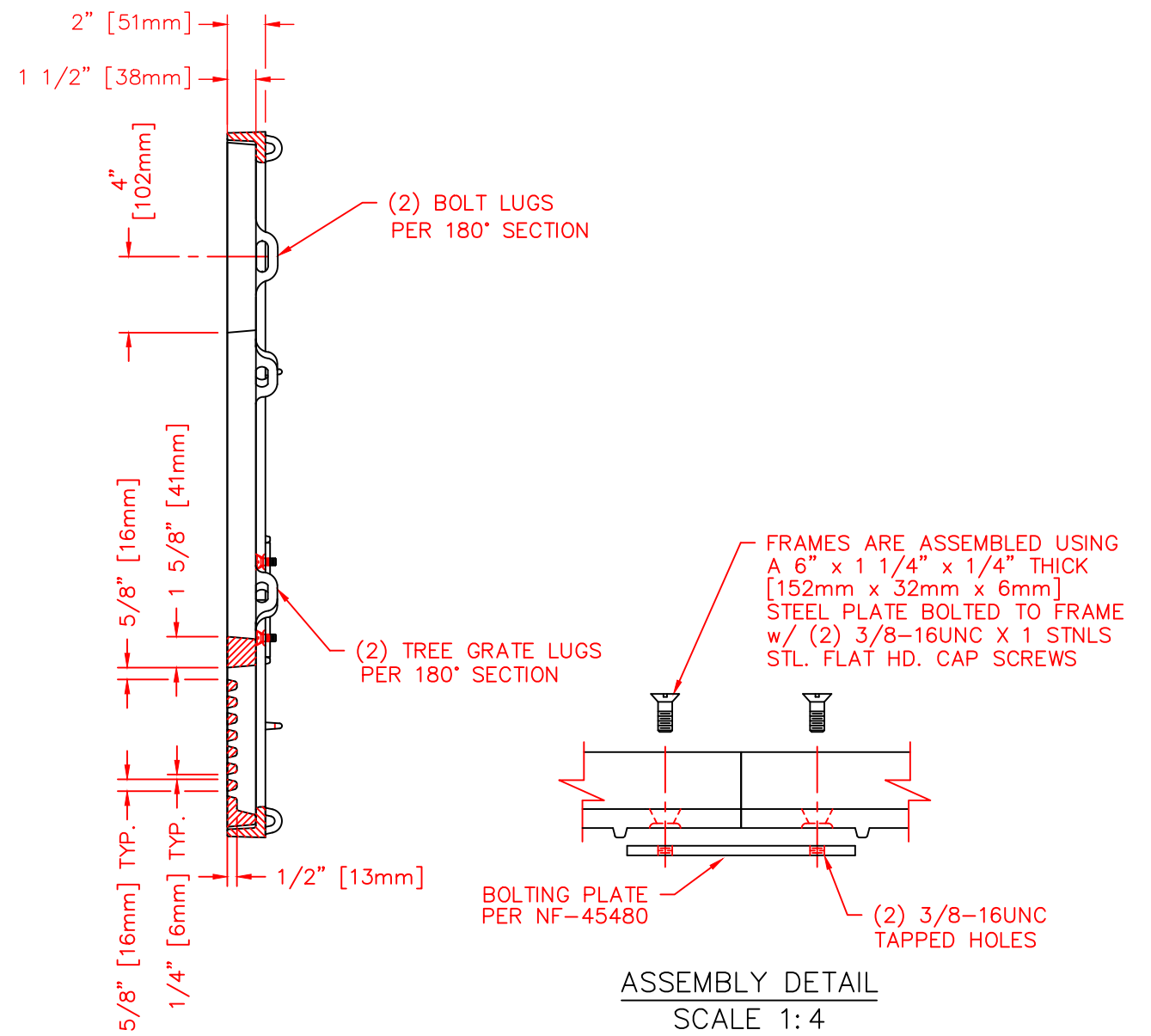
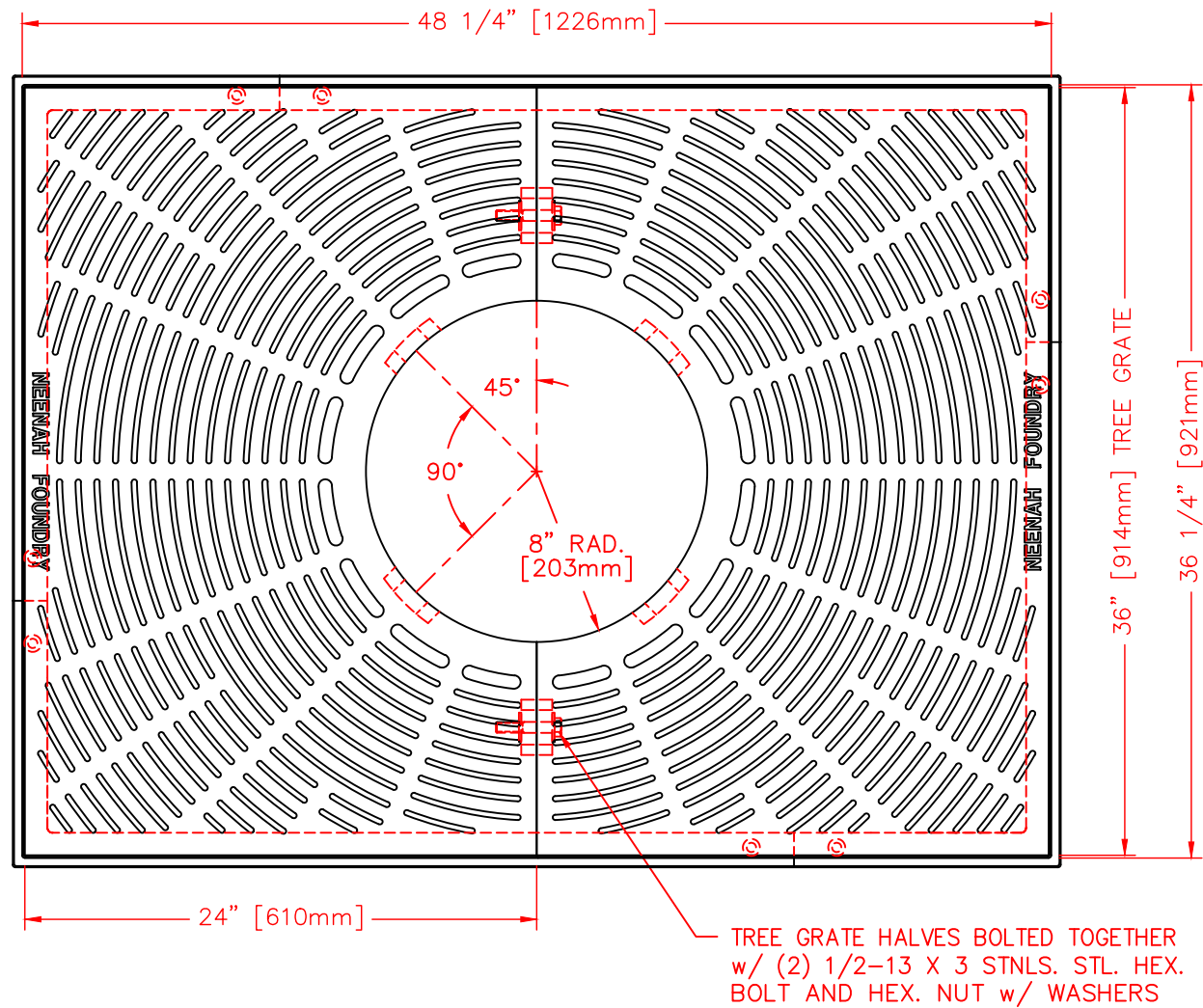

NOTE: ALL DIMENSIONS SHOWN ARE IN ENGLISH AND [METRIC]  
 COMPONENT NOS.: FRAME (2) 8500-3648, FRAME (2) 8500-4848,  
 TREE GRATE (2) 8814-0004  
 MATERIAL: CAST GRAY IRON ASTM A-48, CLASS 35B  
 FINISH: NO PAINT  
 WEIGHT: 324# SET

DR. KMH	SCALE 1/8"=1"	TITLE: R-8814-A TREE GRATE AND FRAME
CH.	DIM CHK.	NEENAH FOUNDRY COMPANY NEENAH WISCONSIN 54956
APP.		
DATE 10-09-2001		NF-8814 195 B



# HOLLAND STONE

CLASSIC SHAPE,  
SMOOTH SURFACE FOR A  
TRADITIONAL LOOK

## PALLET LAYOUT

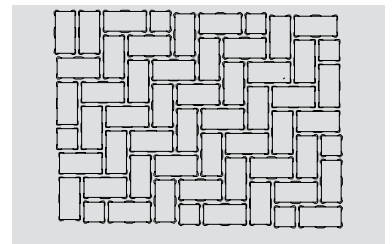
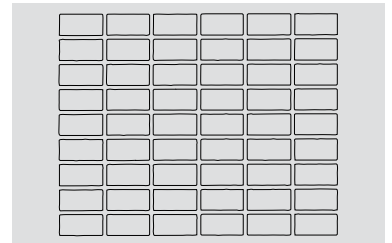

## LAYING PATTERNS

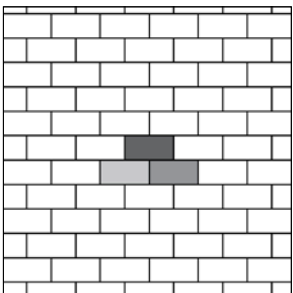

RUNNING BOND PATTERN

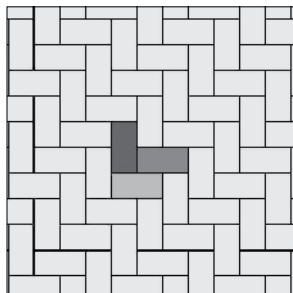

HERRINGBONE PATTERN

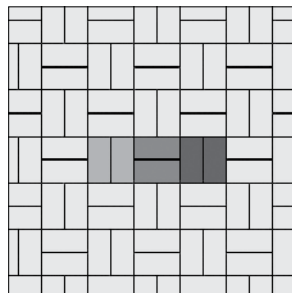

BASKET WEAVE PATTERN

## FEATURES & BENEFITS

- Classic traditional shape
- Optimal shape for maximum interlock and pattern versatility
- Ideal for accent features and border courses
- Can be utilized to construct an ADA-compliant pavement

## SHAPES & SIZES

### HOLLAND STONE | 60MM



4 x 8 x 2 $\frac{3}{8}$

### HOLLAND STONE | 80MM



4 x 8 x 3 $\frac{1}{8}$

*Check with your local Belgard Representative for product availability and color options.*

**BID FORM**  
**Bid No. 24-020-2024-PWI-001**  
**Pine Street One-Way Conversion and Parking Project**

**OWNER: CITY OF FAIRHOPE**  
**PROJECT #: 2024-PWI 001**

**Project Description: PINE STREET ONE-WAY CONVERSION & PARKING PROJECT**

**Project Location: 100 Block of Pine St, Fairhope, AL 36532**

<b>BASE BID</b>					
<b>ITEM DESCRIPTION</b>	<b>ALDOT</b>	<b>UNIT</b>	<b>EST QTY</b>	<b>UNIT PRICE</b>	<b>AMOUNT</b>
Clearing & Grubbing - Trees and Shrubbery at NW Corner	201-A	LS	1		
Demolition - Removal of Structures (Per Plans)	205-A	LS	1		
Removing Asphalt Pavement (Inc. full-depth saw cutting)	206-C	SQ YD	125		
Removal of Concrete Curb/Gutter	206-D	LIN FT	34		
Unclassified Excavation	210-A	CU YD	130		
Milling/Planing Existing Asphalt (1" to 1.5" Deep) (Full Roadway Width)	408-A	SQ YD	515		
Tack Coat	405-A	GAL	25		
Asphalt Wearing - Bituminous Concrete Wearing Surface, 1.50" (165#/SY) Compacted Thickness (With Calculated Overage)	424-A	TON	48		
Asphalt Leveling - Bituminous Concrete Leveling Surface - As required and directed by City Engineer - Project-Wide	424-B	TON	20		
INTERLOCKING CONCRETE UNIT PAVING ON AGGREGATE BASE - Including a subbase, base, Parking delineation and all subsidiary work - per specifications	4##	SQ FT	2360		
8-inch HDPE (ADS N-12)	533-A1	LIN FT	120		
Mobilization	600-A	LUMP SUM	1		
4-inch thick concrete sidewalk 6-foot wide	618-A	SQ YD	80		
4-inch thick concrete sidewalk 8-foot wide (including the required turnaround on the front edge, lamp post block outs and tree wells)	618-A	SQ YD	230		
Curb Ramp at NE corner of Pine & Bancroft	618-D	SQ YD	8		
Inlet - Type: NDS 18" Catch Basin (1182,1884) w/Cast Iron Square Grate (1813)	621-C	EACH	1		
Inlet/Outlet - Type: 3x2.5x2 Outlet Box (Cast In Place) Cast Iron Concave Grate - Neenah 3205 (0001 Frame) (0002 Grate)	621-C	EACH	1		
Concrete Gutter - 30-inch valley - Modified Type M (Including transition to existing curbing at east radii)	623-A	LIN FT	280		
Concrete Curb - 8-inch Header - Modified Type N	623-B	LIN FT	86		
Tree Wells with Neenah Foundry Grate and Frame R-8814-A	6##	EACH	3		
Best Management Practice (BMP's) - See Notes in Contract Documents - Capped at 2.5% of Base Bid	665	LUMP SUM	1		
Geometric Controls	680-A	LUMP SUM	1		
Solid White, Class 2, Type A, Traffic Stripe, 5" Wide - E.P. Line - Both Sides	701-A	MILE	0.10		
Traffic Control Markings, Class 2, Type A - White - Stop Bar and Ped X-ing	703-A	SQ FT	120		
Traffic Control Markings, Class 2, Type A - White - Directional Through Lane-Use Arrow (4 total)	703-A	SQ FT	48		
Traffic Control, To Be Approved - May Includes temporary striping, markings and signage - See Notes in Contract Documents - Capped at 5% of Base Bid	740-A	LUMP SUM	1		
<b>Base Bid Total</b>					
<b>Total Construction Cost:</b>					

<b>ADDITIVE ALTERNATE BID</b>					
<b>ITEM DESCRIPTION</b>	<b>ALDOT</b>	<b>UNIT</b>	<b>EST QTY</b>	<b>UNIT PRICE</b>	<b>AMOUNT</b>
Removing Asphalt Pavement (Min thickness)	206-C	SQ YD	23		
Unclassified Excavation	210-A	CU YD	67		
INTERLOCKING CONCRETE UNIT PAVING ON AGGREGATE BASE - Including a subbase, base, Parking delineation and all subsidiary work - Zone 3	4##	SQ YD	1200		
Concrete Curb - 8-inch Header - Modified Type N	623-B	LIN FT	112		
<b>Additive Alternative Bid Total</b>					
<b>Total Additive Alternative Construction Cost:</b>					



Bid will include all labor, materials, equipment, shipping and postage, overhead, profit, bonds, insurance and all other costs necessary to provide the complete services outlined within this CONTRACT and scope of work.

**Receipt of the following Addenda to these documents is hereby acknowledged by the undersigned (CONTRACTOR to complete below):**

ADDENDUM NO.	DATE ISSUED	ADDENDUM NO.	DATE ISSUED
_____	_____	_____	_____
_____	_____	_____	_____

Each bid must give the full business address of the CONTRACTOR and must be signed by him with his usual signature. Bids by partnerships must furnish the full names of all partners and must be signed with the partnership name by one of the members of the partnership, or by an authorized representative, followed by the signature and designation of the person signing. Bids by corporations must be signed with the legal name of the corporation followed by the name of the State of Incorporation and by the signature and designation of the president, secretary, or other person authorized to bind it in the matter. The name of each person shall also be typed or printed below the signature. A bid by a person who affixes to this signature the word "president," "secretary," "agent," or other designation without disclosing his principal, may be held to be the bid of the individual signing. When requested by the City of Fairhope, Baldwin County, Alabama, satisfactory evidence of the authority of the officer signing in behalf of the corporation shall be furnished.

The undersigned agrees to furnish the goods/services as requested by you for the City of Fairhope, Baldwin County, Alabama in your invitation to bid, and certifies that they will meet or exceed the specifications called for. The undersigned has read all information pertaining to this bid and has resolved all questions. It is also understood and agreed that all prices quoted are F.O.B. described in the bid documents and specifications. The undersigned also affirms he/she has not been in any CONTRACT or collusion among BIDDERS or prospective BIDDERS in restraint of freedom of competition, by CONTRACT to bid at a fixed price or to refrain from bidding or otherwise.

Witness our hands and seals this \_\_\_\_\_ day of \_\_\_\_\_, 2024.

**If Individual or Partnership**

\_\_\_\_\_  
(Name of Individual or Partnership)

\_\_\_\_\_  
(Name of Partner Print)

\_\_\_\_\_  
(Name of Representative Authorized to sign Bids and CONTRACTs for the firm Print)

\_\_\_\_\_  
(Name of Partner Print)

Address \_\_\_\_\_  
\_\_\_\_\_  
\_\_\_\_\_

Phone Number ( ) \_\_\_\_\_ Fax Number ( ) \_\_\_\_\_

E-mail address \_\_\_\_\_ Alabama Contractor's License No. \_\_\_\_\_

Foreign Entity ID (if outside of Alabama) \_\_\_\_\_

**If Corporation or LLC**

Company \_\_\_\_\_

State of Incorporation \_\_\_\_\_

Company Representative \_\_\_\_\_  
( Representative Authorized to sign Bids and CONTRACTs for the firm Print)

Company Representative \_\_\_\_\_  
( Representative Authorized to sign Bids and CONTRACTs for the firm Signature)

Address \_\_\_\_\_  
\_\_\_\_\_  
\_\_\_\_\_

Phone Number ( ) \_\_\_\_\_ Fax Number(\_\_\_\_) \_\_\_\_\_

E-mail address \_\_\_\_\_ AL Contractor's License No. \_\_\_\_\_

Foreign Vendor Id \_\_\_\_\_

**BID PROPOSAL NOTARIZATION:**

STATE OF \_\_\_\_\_ }

COUNTY OF \_\_\_\_\_ }

I, the undersigned authority in and for said State and County, hereby certify that \_\_\_\_\_,  
as \_\_\_\_\_ respectively, of \_\_\_\_\_, whose name is signed to  
the foregoing document and who is known to me, acknowledged before me on this day, that, being informed of the contents  
of the document they executed the same voluntarily on the day the same bears date.

Given under my hand and Notary Seal on this \_\_\_\_\_ day of \_\_\_\_\_, 2024.

NOTARY PUBLIC \_\_\_\_\_

MY COMMISSION EXPIRES \_\_\_\_/\_\_\_\_/\_\_\_\_

**ITEM IV  
CONTRACTOR INFORMATION**

*This Section must be printed, completed, and turned in with your bid response to*

**Bid No. 24-020-2024-PWI-001  
Pine Street One-Way Conversion and Parking Project  
Public Works Project No. 2024-PWI 001**

**Business Organization**

**Name of CONTRACTOR** (exactly as it appears on W-9):

\_\_\_\_\_  
Doing-Business-As Name of CONTRACTOR:

\_\_\_\_\_  
Principal Office Address:

\_\_\_\_\_  
**LOCAL** Telephone Number: \_\_\_\_\_ Toll- Free \_\_\_\_\_  
**LOCAL** Fax Number: \_\_\_\_\_  
Email address: \_\_\_\_\_  
Website: \_\_\_\_\_

**Form of Business Entity** [check one ("X")]

Corporation \_\_\_\_\_  
Partnership \_\_\_\_\_  
Individual \_\_\_\_\_  
Joint Venture \_\_\_\_\_  
Other (describe): \_\_\_\_\_

**Corporation Statement**

If a corporation, answer the following:

Date of incorporation: \_\_\_\_\_

Location of incorporation: \_\_\_\_\_

The corporation is held: Publicly \_\_\_  
Privately \_\_\_

**Partnership Statement**

If a partnership, answer the following:

Date of organization: \_\_\_\_\_

Location of organization: \_\_\_\_\_

The partnership is: General \_\_\_  
Limited \_\_\_

**Joint Venture Statement**

If a Joint Venture, answer the following:

Date of organization: \_\_\_\_\_

Location of organization: \_\_\_\_\_

JV CONTRACT recorded? Yes \_\_\_ No \_\_\_

Contact: \_\_\_\_\_ Email \_\_\_\_\_

Phone \_\_\_\_\_ Fax \_\_\_\_\_

**END OF CONTRACTOR INFORMATION SECTION**

**ITEM V  
INSURANCE**

**3.0 INSURANCE REQUIREMENTS**

Awarded **CONTRACTOR**, at its sole expense, shall obtain and maintain in full force the following insurance to protect the **CONTRACTOR** and the City of Fairhope at limits and coverages specified herein. The City of Fairhope will be listed as an additional insured under the **CONTRACTOR'S** general liability insurance and automobile liability insurance policies, and all other applicable policies and certificates of insurance. These limits and coverages specified are the minimum to be maintained and are not intended to represent the correct insurance needed to fully and adequately protect the awarded **CONTRACTOR**.

3.01 All insurance will be provided by insurers by admitted carriers in the State of Alabama, shall have a minimum A.M. Best rating of A-VII and must be acceptable to the City. Self-insured plans and/or group funds not having an A.M. Best rating must be submitted to the City for prior approval.

3.02 **NO WORK IS TO BE PERFORMED UNTIL PROOF OF COMPLIANCE WITH THE INSURANCE REQUIREMENTS HAS BEEN RECEIVED BY THE CITY.**

3.03 **Worker's Compensation and Employers Liability**

Part One: Statutory Benefits as required by the State of Alabama	
Part Two: Employers Liability	\$100,000 Each Accident
	\$100,000 Each Employee
	\$500,000 Policy Limit

3.04 **U.S. Longshoreman & Harbor workers Act (USL&H)-**

Required if CONTRACT involves work near a navigable Waterway that may be subject to the USL&H law.

3.05 **Maritime Endorsement (Jones Act)-**

Endorsement required if CONTRACT involves the use of a Vessel. Or include coverage for "Master or Members or Crew" under "Protection and Indemnity" coverage (P&I), unless crew is covered under Workers Compensation.

Bodily injury by accident	\$1,000,000 Each Accident
Bodily injury by disease	\$1,000,000 Aggregate

3.06 **Commercial General Liability**

Coverage on an Occurrence form with a combined single limit of (Bodily Injury and Property Damage combined as follows:

Each Occurrence	\$1,000,000
Personal and Advertising Injury	\$1,000,000
Products/Completed Operation Aggregate	\$2,000,000
General Aggregate	\$2,000,000

Coverage to include:

- Premises and operations
- Personal Injury and Advertising Injury
- Products/Completed Operations
- Independent BIDDERS
- Blanket Contractual Liability
- Explosion, Collapse and Underground hazards
- Broad Form Property Damage
- Railroad Protective Liability Insurance if work involves construction, demolition or maintenance operations on or within 50 feet of a railroad.

3.07 **Automobile Liability**

Covering all Owned, Non-Owned, and Hired vehicles with a limit of no less than \$1,000,000 combined single limit of Bodily Injury and property damage per occurrence.

3.08 **Certificate of Insurance**

**A Certificate of Insurance evidencing the above minimum requirements must be provided to and accepted by the City PRIOR to commencement of any work on the CONTRACT. Each policy shall be endorsed to provide ten (10) days written notice of cancellation to the CITY**

Such insurance as is afforded by the above policies covers the operations undertaken by the insured with respect to the construction of the project above designated. The insurance afforded by the above designated policies, specimen copies of which have been filed with the **CITY**, and to each of which is attached for following endorsement.

The insurer agrees with the insured as follows:

1. That it will furnish to said City of Fairhope a certificate of insurance in triplicate on a form approved for such purpose by said **CITY**, setting forth the pertinent information regarding the policy to which this endorsement is attached, for each project of said **CITY** to which the policy applies.
2. That it will attach to each said certificate of insurance executed copies of any endorsement other than this endorsement which are attached to said policy at the time said policy is issued, provided only that said endorsements affect the coverage of said policy in respect of operations involved in the construction of the projects of said **CITY** to which the policy applies.
3. That it will mail to the City Council of the City of Fairhope three executed copies of each endorsement subsequently issued to become a part of said policy provided only that endorsement affects the coverages of said policy in respect of operations involved in the construction of the project of said **CITY** which the policy applies, and provided further that such endorsement shall not be effective unless such notice is given to the **CITY** at the same time that notice thereof is given to the insured.
4. That it will mail to the City Council of the **CITY** of Fairhope at least ten days before the effective date thereof notice of cancellation of said policy, provided no cancellation shall be effective unless such notice is given to the **CITY**.

**END OF INSURANCE REQUIREMENTS**

ITEM VI



City of Fairhope  
CONTRACT

This **CONTRACT** is made this \_\_\_\_\_ day of \_\_\_\_\_, 202\_\_, by and between the City of Fairhope (hereinafter referred to as the "**OWNER**") and \_\_\_\_\_ (hereinafter referred to as the "**CONTRACTOR**"), for

**Bid Number/Name**

The **OWNER** and the **CONTRACTOR** agree as set forth below:

1. The **CONTRACT** consists of all the items contained within this **CONTRACT**, The Proposal Package, Proposal, Scope of Work and Specifications, drawings (if applicable), Addenda, Amendments, and City of Fairhope Standard Terms and Conditions, which are attached hereto and made a part hereof, as if fully contained herein; for the performance of all work and the furnishing of all labor and materials required for completion of the **WORK**.
2. The **CONTRACTOR** shall perform all the **WORK** described herein.
3. The **WORK** to be performed under this **CONTRACT** shall be commenced upon execution of this **CONTRACT** within number (DAYS) days of the date specified in the *Notice to Proceed* (NTP) to be issued to the **CONTRACTOR** by the **OWNER**, or its authorized representative. The work shall be completed, subject to authorized adjustments, within (DAYS) consecutive calendar days from and after the commencement date stipulated in said *Notice to Proceed*. Liquidated damages for non-completion of the work within this time limit will be assessed at the rate of (DOLLARS) per working day.
4. The **OWNER** shall pay the **CONTRACTOR** in current funds for the performance of the **WORK**, the **CONTRACT SUM** of \_\_\_\_\_ DOLLARS (\$ \_\_\_\_\_). This represents a **LUMP SUM** payment for performance of the **WORK**, which payment shall be issued after the Contract is fully performed and the **OWNER** has inspected the **WORK**.
5. **General Conditions**
  - a. **Indemnity:** The **CONTRACTOR** hereby agrees to indemnify and save harmless the **OWNER**, its officers, agent, and employees, from and against any and all liabilities, claims, demands, damages, fines, fees, expenses, penalties, suits, proceedings, actions and cost of actions, including reasonable attorneys' fees for trial and on appeal, of any kind and nature, arising or growing out of, or in any way connected with the performance of this **CONTRACT**, to the extent caused by a negligent act or omission of the **CONTRACTOR**, their agents, servants, employees, **SUB-CONTRACTORS**, or others associated with the **CONTRACTOR**. The **CONTRACTOR** shall be responsible for damage to any elevator equipment excluded from this agreement, or damage or injury caused by any equipment excluded from this agreement, to the extent that the damage or injury is caused by a negligent act or omission of the **CONTRACTOR**.
  - b. **Notification and Accident Reports:** In the event of accidents of any kind, the **CONTRACTOR** shall notify the **OWNER** immediately and furnish, without delay, copies of all such accident reports to the **OWNER**. If in the performance of their Work, the **CONTRACTOR** fails to immediately report an accident to the **OWNER**, of which the **CONTRACTOR** has knowledge of and which results in a fine

levied against the **OWNER** then the **CONTRACTOR** shall be responsible for all fines levied against the **OWNER**.

## 6. Termination of Agreement

- a. Termination for Default: Performance of Work under this Agreement may be terminated by the **OWNER**, in whole or in part, in writing, whenever the **OWNER** determines that the **CONTRACTOR** has failed to meet the requirements of this Agreement.
  - i. The Owner has a right to terminate for default if the contractor fails to make delivery of material or does not perform the work, or if the Contractor fails to perform the Work within the time specified in the Agreement, or if the Contractor fails to perform any other provision of the Agreement.
  - ii. Failure on the part of the Contractor to deliver or perform the Work within the time specified, or within a reasonable time as determined by the Owner, or failure on the part of the Contractor to make replacements of rejected articles, or Work when so requested, immediately or as directed by the Owner, shall constitute authority for the Owner to purchase in the open market, articles or Work of comparable grade to replace the articles or Work rejected, not delivered or completed. On all such purchases, the Contractor shall reimburse the Owner within a reasonable time specified by the Owner for any expense incurred in excess of Agreement prices.
  - iii. Such purchases shall be deducted from the Agreement sum. If public necessity demands it, the Owner reserves the right to utilize services or use and/or consume articles delivered, which are standard in quality, subject to an adjustment of price to be determined by the Owner.
- b. Termination for Convenience: The **OWNER** has the absolute right to terminate the Agreement upon "Award of Contract" another **CONTRACTOR**, to perform work referenced herein. In such event, payment of the monthly contract fee shall cease on the date of cancellation of the **CONTRACT** by the **OWNER**.

## 7. Warranty

- a. The **CONTRACTOR** warrants that the Work including equipment and materials provided shall conform to the professional standards of care and practice in effect at the time the Work is performed, be of the highest quality, and be free from all faults, defects, or errors. If the **CONTRACTOR** is notified in writing of a fault, deficiency or error in the Work, the **CONTRACTOR** shall at the **OWNER**'s option, either re-perform such portions of the Work to correct such fault, defect, or error, at no additional cost to the **OWNER**, or refund to the **OWNER** the charge paid by the **OWNER**, which is attributable to such portions of the faulty, defective or erroneous Work, including costs for re-performance or Work provided by other **CONTRACTORS**. All equipment and materials provided by the **CONTRACTOR** shall be merchantable and for the purpose intended and meet all industry quality standards.

## 8. Time of Completion

The **OWNER** and **CONTRACTOR** understand and agree that time is of the essence in the performance of this Agreement. The **CONTRACTOR** or **OWNER**, respectively, shall not be liable for any loss or damage, resulting from any delay or failure to perform its contractual obligations within the time specified, due to acts of God, actions or regulations by any governmental entity or representative, strikes, fire, water damage, loss of power, loss of funding or any other causes, contingencies, or circumstances not subject to the **OWNER** or **CONTRACTOR**'S control, respectively, whether of a similar or dissimilar nature, which prevent or hinder the performance of the **OWNER**'S or **CONTRACTOR**'S contractual obligations, respectively. Any such causes of delay, even though existing on the date of the **CONTRACT**, or on the day

of the start of Work, shall extend the time of the OWNER'S or CONTRACTOR'S performance respectively, by the length of the delays occasioned thereby, including delays reasonably incident to the resumption of normal Work schedules.

**However, under such circumstances as described herein, the OWNER may, at their discretion, cancel this CONTRACT for their own convenience.**

**9. Insurance Requirements**

See **ATTACHMENT B**

**10. Acceptance of Work**

The OWNER will be deemed to have accepted the Work after the OWNER agrees the Work is completed. In the event Work furnished under the CONTRACT is found to be defective or does not conform to the intent of the CONTRACT, the CONTRACTOR shall, within ten (10) days from receipt of notice from the OWNER, correct the deficiencies. Failure on the part of the CONTRACTOR to properly correct the deficiencies within the time period allowed will constitute the OWNER'S right to cancel the CONTRACT immediately, upon written notice to the CONTRACTOR.

**11. Correction of Work**

The CONTRACTOR shall promptly correct all Work rejected by the OWNER as faulty, defective or failing to conform to the CONTRACT, whether observed before or after completion of the Work. The CONTRACTOR shall bear all costs of correcting such rejected Work.

**12. Right to Audit**

The CONTRACTOR shall maintain documentation of all work performed. The CONTRACTOR shall make any and all documentation available to the OWNER at all reasonable times, for inspections and audit by the OWNER, during the entire term of the CONTRACT, and for a period of three (3) years after the expiration of this CONTRACT.

**13. CONTRACT Rights and Remedies**

The CONTRACTOR shall maintain documentation of all work performed. The CONTRACTOR shall make any and all documentation available to the OWNER at all reasonable times, for inspections and audit by the OWNER, during the entire term of the CONTRACT, and for a period of three (3) years after the expiration of this CONTRACT.

**14. Time is of the Essence**

The Owner and CONTRACTOR agree that time is of the essence in the performance of Work called for under this CONTRACT. The CONTRACTOR agrees that all work will be accomplished regularly, diligently and uninterrupted at such a rate of progress as will ensure full completion thereof within reasonable time periods.

**15. Safety Measures**

The CONTRACTOR shall take all necessary precautions for the safety of the OWNER'S and CONTRACTOR'S employees at the Work site, and shall erect and properly maintain at all times, all necessary safeguards for the protection of the workmen and the public. The CONTRACTOR shall post signs warning against hazards in and around the Work site.



**16. Extra Work and Associated Costs**

- a. Changes in the Work: The OWNER, without invalidating the CONTRACT, may order changes in the Work within the general scope of this CONTRACT, consisting of additions, deletions, or other revision, the CONTRACT price and time for execution of the Work being adjusted accordingly.
- b. All such changes in the Work shall be authorized by a written Amendment to the CONTRACT or a separate Change Order and shall be executed under the applicable conditions of the CONTRACT.

**17. Familiarity with the Work**

The CONTRACTOR, by executing this CONTRACT, acknowledges full understanding of the extent and character of the Work required and the conditions surrounding the performance thereof. The OWNER will not be responsible for any alleged misunderstanding of conditions surrounding the performance thereof. It is understood that execution of the CONTRACT by the CONTRACTOR serves as his stated commitment to fulfill all requirements and conditions referred to in this CONTRACT.

**18. Scope of Work**

See **ATTACHMENT B**

**19. Contractor Liability**

Nothing in this CONTRACT shall be construed to mean that the CONTRACTOR assumes any liability for damages or otherwise, on account of accidents to persons or property, except those resulting from negligence on the part of the CONTRACTOR or its agents, servants, employees, and subcontractors.

**20. Miscellaneous Provisions**

- a. The CONTRACTOR shall not employ SUB-CONTRACTORS without the express written permission of the OWNER.
- b. The CONTRACTOR shall not assign the CONTRACT or sublet it as a whole without the express written permission of the OWNER. The OWNER may assign the CONTRACT, or sublet it as a whole, without the consent of the CONTRACTOR.
- c. No waiver, alteration, consent, or modification of any of the provisions of the CONTRACT shall be binding unless in writing and signed by the OWNER and CONTRACTOR.
- d. The CONTRACTOR is to procure all permits, licenses, and certificates, or any approvals of plans or specifications as may be required by Federal, State, Local Laws, ordinances, rules, and regulations, for the proper execution and completion of Work covered under this CONTRACT.
- e. The CONTRACTOR shall at all times keep the Work area free from accumulation of waste materials or rubbish caused by his operations, and promptly remove any such materials to an area designated by the OWNER or remove to a waste site as directed by the OWNER. If the CONTRACTOR fails to clean up the Work site, the OWNER will complete the task and charge the CONTRACTOR for such services.
- f. This CONTRACT is considered a non-exclusive Agreement between the parties.
- g. This CONTRACT is deemed to be under and shall be governed by and construed according to the laws of the State of Alabama.
- h. Any litigation arising out of the CONTRACT shall be heard in the Courts of Baldwin County, Alabama.



**IF INDIVIDUAL OR PARTNERSHIP**

Individual or Partnership

Print Name of Partner

Print Name of Representative Authorized to Sign  
Contracts for the firm

Print Name of Partner

Signature of Representative Authorized to Sign  
Contracts for the firm

Print Name of Partner

Address

Address

City, State, Zip Code

Phone Number

Fax Number

Primary E-mail Address

AL General Contractor License No. (Attach Copy)

AL General Contractor License Major Categories

AL General Contractor Specialties

AL Foreign Corporation Entity ID (Required of Out of State Vendors)

**IF CORPORATION OR LLC**

Company

State of Incorporation

**Company Representative**

Print Name of Representative Authorized to Sign  
Contracts for the firm

Signature of Representative Authorized to Sign  
Contracts for the firm

Address

Address

City, State, Zip Code

\_\_\_\_\_  
Phone Number

\_\_\_\_\_  
Fax Number

\_\_\_\_\_  
Primary E-mail Address

\_\_\_\_\_  
AL General Contractor License No. (Attach Copy)

\_\_\_\_\_  
AL General Contractor License Major Categories

\_\_\_\_\_  
AL General Contractor Specialties

\_\_\_\_\_  
AL Foreign Corporation Entity ID (Required of Out of State Vendors)

**NOTARY FOR INDIVIDUAL, PARTNERSHIP, CORPORATION, OR LLC**

STATE OF \_\_\_\_\_ }  
COUNTY OF \_\_\_\_\_ }

I, the undersigned authority in and for said State and County, hereby certify that \_\_\_\_\_ As  
Name

\_\_\_\_\_ respectively of \_\_\_\_\_  
Title Company Name

Whose name is signed in the foregoing document and who is known to me, acknowledged before me on this day, being informed of the contents of the document they executed the same voluntarily on the day the same bears date.

Given under my hand and Notary Seal on this \_\_\_\_\_ day of \_\_\_\_\_, 202\_\_.

NOTARY PUBLIC \_\_\_\_\_

MY COMMISSION EXPIRES \_\_\_\_\_



## **ITEM VII**

### ***CITY OF FAIRHOPE***

### ***STANDARD TERMS AND CONDITIONS***

#### **1. ACCEPTANCE OF AGREEMENT**

This Agreement contains all terms and conditions agreed upon by the Owner and Winning bidder. No other agreement, oral or otherwise, regarding the subject matter of this Agreement shall be deemed to exist or to bind either party hereto. The Winning Bidder shall not employ Subcontractors without the express written permission of the Owner. No waiver, alteration, consent or modification of any of the provisions of the Agreement shall be binding unless in writing and signed by the Owner and Contractor. This Agreement shall not be construed against the party or parties preparing it. It shall be construed as if all the parties and each of them jointly prepared this Agreement, and any uncertainty or ambiguity shall not be interpreted against one or more parties.

#### **2. ACCEPTANCE OF WORK**

The City of Fairhope will be deemed to have accepted the Work after the City of Fairhope agrees the Work is completed by signature on delivery or service tickets. In the event Work furnished under the Contract / Agreement / Purchase Order is found to be defective or does not conform to the intent of the Contract / Agreement / Purchase Order, the awarded vendor shall, after receipt of notice from the City of Fairhope, correct the deficiencies. Failure on the part of the awarded vendor to properly correct the deficiencies within the time period allowed will constitute the City of Fairhope's right to cancel the Contract / Agreement / Purchase Order immediately, upon written notice to the awarded vendor.

#### **3. ADDENDA**

All Addenda are part of the Contract Documents. Include resultant costs in the Bid. Addenda will be issued by email to all Bidders on record and posted to the City of Fairhope website [www.FairhopeAL.gov](http://www.FairhopeAL.gov). It is the responsibility of the bidder to verify that all addenda have been received, and to include all signed addenda in the bid submission

#### **4. ADDITIONAL ORDERS**

Unless it is specifically stated to the contrary in the bid response, the City of Fairhope reserves the option to place additional orders against a contract awarded as a result of this solicitation at the same terms and conditions; to extend the renewal date until a new bid is in place, if it is mutually agreeable.

#### **5. APPLICABLE LAW**

This Agreement is deemed to be under and shall be governed by and construed according to the laws of the State of Alabama. Any litigation arising out of the Agreement shall be heard in the Courts of Baldwin County, Alabama.

#### **6. ASSIGNMENT**

The awarded vendor shall not assign the Contract / Agreement / Purchase Order or sublet it as a whole without the express written permission of the City of Fairhope. The awarded vendor shall not assign any payment due them hereunder, without the express written permission of City of Fairhope. The City of Fairhope may assign the Contract / Agreement / Purchase Order, or sublet it as a whole, without the consent of the awarded vendor.

#### **7. ASSURANCE OF NON-CONVICTION OF BRIBERY**

The bidder hereby declares and affirms that, to its best knowledge, none of its officers, directors, or partners and none of its employees directly involved in obtaining contracts has been convicted of bribery, attempted bribery, or conspiracy to bribe under the laws of any state or Federal government.

**8. AWARD CONSIDERATION**

The following factors will be considered in determining the lowest **responsible** bidder: Overall quality, Conformity with specifications both general and specific, Purposes for which materials or services are required, Delivery dates and time required for delivery, Unit acquisition cost, financial ability to meet the contract, previous performance, facilities and equipment, availability of repair parts, experience, delivery promise, terms of payments, compatibility as required, other costs, and other objective and accountable factors which are reasonable.

**9. AWARD OR REJECTION OF BIDS**

The Bid will be awarded to the lowest responsible bidder complying with conditions of the invitation for bids, provided his bid is reasonable and it is in the interest of the City of Fairhope to accept it. The bidder to whom the award is made will be notified at the earliest possible date. The City of Fairhope, however, reserves the right to reject any and all bids and to waive any informality in bids received whenever such rejection or waiver is in the interest to the City of Fairhope.

**10. BACK ORDERS**

If it is necessary to back order any items, the vendor must notify the Purchasing Department and advise as to the expected shipping or delivery date. If this date is not acceptable, the City of Fairhope may seek remedies for default.

**11. BID AND PERFORMANCE SECURITY**

If bid security is required, a bid bond or cashier's check in the amount indicated on the bid cover must accompany the bid and be made payable to The City of Fairhope of Baldwin County, AL. Corporate or certified checks are not acceptable. Bonds must be in a form satisfactory to the City and underwritten by a company licensed to issue bonds in the State of Alabama. If bid security fails to accompany the bid, it shall be deemed unresponsive, unless the Purchasing Manager deems the failure to be non-substantial. All checks will be returned to the bidders after the contract has been approved. If a performance bond is required, the successful bidder will be notified after the awarding of the contract.

**12. BRAND NAMES**

Reference to brand names and numbers is descriptive, but not restrictive, unless otherwise specified. Bids on equivalent items meeting the standards of quality thereby indicated will be considered, providing the bid clearly describes the article offered and indicates how it differs from the referenced brands. Descriptive literature or manufacturers specifications plus any supplemental information necessary for comparison purposes should be submitted with the bid or the bid on that item may be rejected. Reference to literature submitted with a previous bid or on file with the Division of Purchasing will not satisfy this requirement. The burden is on the bidder to demonstrate that the item bid is equivalent to the item specified in the ITB. Bids without sufficient documentation to fully support equality, may be considered non-responsive. Reference by the City of Fairhope in the ITB to available existing specifications shall be sufficient to make the terms of such specifications binding on the bidder. Unless the bidder specifies otherwise in its bid, it is understood the bidder is offering a referenced brand item as specified in the ITB or is bidding as specified when no brand is referenced. Failure to examine drawings, specifications and instructions will be at the bidder's risk.

**13. BUSINESS LICENSE**

The vendor selected to enter into a Contract / Agreement with the City of Fairhope must be licensed to do business in the City of Fairhope prior to commencement of any work under the contract. Delivery of goods or services to the City of Fairhope by Purchase Order have detailed and varied Business License requirements. In all instances that require a business license. Awarded vendor will provide proof of possessing a current City of Fairhope Business License. Prospective bidders will not be required to possess a City of Fairhope Business License prior to award.

**14. CANCELLATION OF / CONTRACT / AGREEMENT / PURCHASE ORDER / LEASE**

A purchase order can be canceled in whole or in part when awarded vendor fails to deliver or perform as specified. Cancellation of a purchase order can only be made by a written purchase order change (POC) from the City of Fairhope. A term contract, lease or agreement can be canceled by the City of Fairhope, for justifiable cause, or convenience, by written notice.

**15. CERTIFICATION PURSUANT TO ACT NO. 2006-557**

Alabama law (section 41-4-116, code of Alabama 1975) provides that every bid submitted and contract executed shall contain a certification that the vendor, contractor, and all of its affiliates that make sales for delivery into Alabama or leases for use in Alabama are registered, collecting, and remitting Alabama state and local sales, use, and/or lease tax on all taxable sales and leases into Alabama. By submitting this bid, the bidder is hereby certifying that they are in full compliance with act no. 2006-557, they are not barred from bidding or entering into a contract pursuant to 41-4-116, and acknowledges that the awarding authority may declare the contract void if the certification is false. All corporations must register to do business in Alabama with the Office of the Secretary of State. Their address is:

**Office of the Secretary of State**

P.O. Box 5616

Montgomery, AL 36103

(334) 242-5324

Fax: (334) 240-3138

<http://www.sos.state.al.us/index.aspx>

The Foreign Corporation form is online at <http://www.sos.state.al.us/downloads/dl1.cfm>.

**16. COST OF REMEDYING DEFECTS**

All defects, indirect and consequential costs of correcting, removing, or replacing any or all of the defective materials or equipment will be charged against the awarded vendor.

**17. DELIVERY OF BID**

Bids must be received in the Purchasing Office by the date and time specified on the bid cover. All bids will be accepted until the time and date stated on the bid cover. No bids will be accepted that extend past the time and date on the bid cover. The time of receipt shall be determined by the time clock stamp in the Purchasing Department. Bids submitted by U.S. Mail must be received by the City of Fairhope of Baldwin County, Alabama, in the City of Fairhope offices, 555 South Section St., Fairhope, Al., unless otherwise specified.

**18. DELIVERY**

The number of calendar days required for delivery after receipt of a purchase order shall be stated in the RFQ / ITB / RFP and /or Purchase Orders. When no time is stated in the document, the time shall be fourteen (14) calendar days after receipt of order. If a shipment is not made within the time period specified, the Purchase Order may be canceled.

**19. ENVIRONMENTAL REQUIREMENTS**

All products will be clearly labeled for their intended use. Each delivery of product or materials will include a Material Safety Data Sheet (MSDS) for all materials that require an MSDS. All manufacturers/distributors of hazardous substances, including any of the items listed on this bid/quote/ contract and subsequent award must include completed material safety data sheet (MSDS) for each hazardous material. Additionally, each container of hazardous materials must be appropriately labeled with:

- a) The identity of the hazardous material,
- b) Appropriate hazard warnings, and manufacturer, importer, or other responsible party.

**20. EQUIPMENT DEMONSTRATION**

The City of Fairhope may require equipment/ product materials or service techniques to be demonstrated at a time, date, and location to be specified by the City of Fairhope.

**21. EQUIPMENT ELECTRICAL CERTIFICATION**

All electrical equipment purchased shall conform to, and be identified in, the applicable standard(s), or otherwise be certified as applicable, as of the bid opening date and time, by Underwriters Laboratories, Inc., or other recognized laboratory facility. Bidder must provide satisfactory documentation with returned bid that all such equipment meets the applicable product standard or has otherwise been certified as outlined above. Unless indicated in the bid document, the above certification shall apply to the equipment itself, not the individual components of that equipment.

**22. ERRORS IN BID**

Bidders are assumed to be informed regarding conditions, requirements, and specifications prior to submitting bids. Failure to do so will be at the bidder's risk. Bids already submitted may be withdrawn without penalty prior to bid opening. Errors discovered after the bid opening may not be corrected.

**23. FORCE MAJEURE**

Neither the City nor the awarded vendor shall be deemed in breach of any contract / Purchase Order or Agreement which may result from this proposal submission if it is prevented from performing any of the obligations hereunder by reason of Acts of God, acts of the public enemy, acts of superior governmental authority, strikes or labor disputes, floods, riots, rebellion, sabotage, or any similar other unforeseeable causes beyond its control and not due to its fault or negligence. Each party shall notify the other immediately in writing of the cause of such after the beginning period thereof. The awarded vendor may request cancellation and the City of Fairhope may grant the request if performance is prevented by any of the above referenced causes, or other unavoidable circumstances not attributable to the fault or negligence of the vendor. The burden of proof for such relief rests with the vendor. All correspondence pertaining to cancellation of a purchase order or term contract must be addressed to the City of Fairhope Purchasing Manager.

**24. HAZARDOUS AND TOXIC SUBSTANCES**

Bidder must comply with all applicable Federal, State, County and City laws, ordinances and regulations relating to hazardous and toxic substances, including such laws, ordinances and regulations pertaining to information hazardous and toxic substances, and as amended from time to time. Bidder shall provide the City of Fairhope with a "Material Safety Data Sheet" for all goods that carry one.

**25. INDEMNITY**

Indemnity: The awarded vendor hereby agrees to indemnify and save harmless the City of Fairhope, its officers, agent, and employees, from and against any and all liabilities, claims, demands, damages, fines, fees, expenses, penalties, suits, proceedings, actions and cost of actions, including reasonable attorney fees for trial and on appeal, of any kind and nature, arising or growing out of, or in any way connected with the performance of this Contract / Agreement / Purchase Order, to the extent caused by a negligent act or omission of the awarded vendor, their agents, servants, employees, Subcontractors, or others associated with the awarded vendor. The awarded vendor shall be responsible for damage to any equipment excluded from this agreement, or damage or injury caused by any equipment excluded from this agreement, only to the extent that the damage or injury is caused by a negligent act or omission of the awarded vendor or caused by failure of the awarded vendor's supplied product to perform as specified.

**26. INSPECTION**

All materials, workmanship, equipment, and supplies are subject to inspection and test at any source or time. Final inspection, acceptance or rejection will be made at delivery destination. Goods that do not meet specifications will be rejected unless substitutions have been approved by the City of Fairhope. Failure to inspect or to reject upon receipt, however, does not relieve the awarded vendor of liability. When subsequent tests, after receipt, are conducted and when such tests reveal a failure to meet specifications, the City of Fairhope will reject the goods and the awarded vendor shall immediately supply goods meeting specifications or the City of Fairhope may seek damages including but not limited to the testing expense, regardless of whether a part of or all of the goods have been consumed through the testing process. Rejected goods shall be removed by the awarded vendor promptly after rejection, at his expense. If not removed in fourteen (14) calendar days, they may be disposed of at the discretion of the City of Fairhope. Disposal costs will be the awarded vendor's responsibility.



**27. INSPECTION OF PREMISES**

At reasonable times, the City may inspect those areas of the awarded vendor's place of business that are related to the performance of a Contract / Agreement / Purchase Order. If the City makes such an inspection, the awarded vendor must provide reasonable assistance. The City of Fairhope reserves the right on demand and without notice all the vendor's files associated with a subsequent Contract / Agreement / Purchase Order where payments are based on the awarded vendor's record of time, salaries, materials, or actual expenses. This same clause will apply to any subcontractors assigned to the Contract / Agreement / Purchase Order.

**28. INSURANCE**

If a Contract / Agreement / Purchase Order results from this RFQ / ITB / RFP, or other form of solicitation, the awarded vendor shall maintain such insurance as will indemnify and hold harmless the City of Fairhope from Workmen's Compensation and Public Liability claims from property damage and personal injury, including death, which may arise from the awarded vendor's operations under this Contract / Agreement / Purchase Order, or by anyone directly or indirectly employed by him/her.

**29. INVITATION TO BID**

Any provisions made in the RFQ / ITB / RFP, or other form of solicitation, supersedes any provisions outlined here in the General Terms and Conditions.

**30. INVOICING, DELIVERY, PACKAGING**

Invoices shall be prepared only after ordered materials have been delivered. All invoices must show the purchase order number. Unless otherwise specified in writing, vendors shall not ship any material without an authorized Purchase Order from the City of Fairhope Purchasing Department. All packages delivered must show the purchase order number. The awarded vendor will be required to furnish all materials, equipment and/or service called for at the bid price quoted. In the event the awarded vendor fails to deliver within a reasonable period of time, as determined by the City of Fairhope, the right is reserved to cancel the award and subsequent purchase order and purchase from the next lowest responsible bidder the items needed. The original awarded vendor will be back charged the difference between the original contract price and the price the City of Fairhope has to pay as a result of the failure to perform by the original awarded vendor. All bids will remain firm for acceptance for 60 days from the date of bid opening. Prices shall be net F.O.B., Prepaid and Allow, City of Fairhope chosen site, Baldwin County, AL. The title and risk of loss of the goods will not pass to the City of Fairhope until receipt and acceptance takes place at the F.O.B. point.

**31. LABELING**

Individual shipping cartons shall be labeled with the name "City of Fairhope", Purchase Order Number, and where applicable, Contract Number, date of manufacture, batch number, storage requirements, conditions, and recommended shelf life. Bidders are encouraged to offer product packaging with recycled content.

**32. LOSS OR DAMAGE IN TRANSIT**

Delivery by a vendor to a common carrier does not constitute delivery to the City of Fairhope. Any claim for loss or damage incurred during delivery shall be between the vendor and the carrier. The City of Fairhope accepts title only after satisfactory receipt at the delivery point. The City of Fairhope shall note all visible damages on the freight bill and may refuse the damaged goods. The vendor shall make immediate replacement of the damaged merchandise or be subject to damages for breach of contract. If damage is to a small portion of a total shipment and the City of Fairhope will not be inconvenienced because of the shortage, the vendor may be permitted by the Purchasing Manager to deduct the amount of damage or loss from its invoice, in lieu of replacement. Risk of loss during delivery is borne by the vendor until the goods have been accepted by the City of Fairhope, unless otherwise specified in the RFQ / ITB / RFP or other form of solicitation.

**33. MANDATORY SITE VISIT**

If the RFQ / ITB / RFP or other form of solicitation requires a mandatory site visit, bidders must inspect the site where installation or service is to take place to obtain a full understanding of scope of work outlined therein. Date of site visit will be determined by the City of Fairhope.

**34. MONITORING OF SERVICES**

Performance of services will be monitored by the requisitioning department and/or the Purchasing Department, and evaluation reports may be filed with the Purchasing Department. Performance not meeting specifications will result in cancellation of Contract / Agreement / Purchase Order and may result in vendor being removed from the vendor list.

**35. NONCONFORMING MERCHANDISE**

When merchandise received from the lowest responsible bidder is not in accordance with the purchase order, it will be returned to the bidder, at bidder's expense.

**36. NON-DISCRIMINATION**

The City of Fairhope is an Equal Opportunity Employer and requires that all contractors comply with the Equal Employment Opportunity laws and the provisions of the Contract / Agreement / Purchase Order documents in this regard. The City also encourages and supports the utilization of Minority Business Enterprises on this and all public bids.

**37. NON-EXCLUSIVE**

Unless otherwise specified, this Contract / Agreement / Purchase Order is considered a non-exclusive Contract / Agreement / Purchase Order between the parties.

**38. NOTIFICATION AND ACCIDENT REPORTS**

In the event of accidents of any kind, in the performance of a Contract / Agreement / Purchase Order, the awarded vendor shall notify the City of Fairhope immediately and furnish, without delay, copies of all such accident reports to the City of Fairhope. If in the performance of their Work, the awarded vendor fails to immediately report an accident to the City of Fairhope, of which the awarded vendor has knowledge of and which results in a fine levied against the City of Fairhope then the awarded vendor shall be responsible for all fines levied against the City of Fairhope.

**39. PACKAGING**

All goods must be packaged in new packing containers. Packing that meets the requirements of common carriers is acceptable, unless otherwise required. A packing slip or invoice must accompany all shipments and must reference the purchase order number. Unless otherwise specified, goods are to be packaged in cartons meeting federal specifications and shipped on non-returnable pallets.

**40. PATENTS**

Awarded Vendor guarantees that the sale and / or use of goods will not infringe upon any U.S. or foreign patent. Awarded vendor will at his / her own expense, indemnify, protect and save harmless the City of Fairhope, on any patent claims arising from the purchase of goods or services.

**41. PAYMENT**

Invoices -- Upon completion of service and delivery of materials specified in the applicable Contract / Agreement / Purchase Order, awarded vendor will submit an invoice and signed delivery ticket to:

City of Fairhope  
Accounts Payable Department  
P.O. Box 429  
Fairhope, Al. 36533

All invoices must reference appropriate Purchase Order Numbers Payment of Invoice: All invoices received by the City of Fairhope are payable within thirty (30) days from the date of receipt by the City of Fairhope, provided they are approved by the City of Fairhope.

**42. PAYMENT WITHHELD**

Payment may be withheld until all items have been delivered and all requirements of the Contract / Agreement / Purchase Order have been fulfilled

**43. PRODUCT TESTING**

Vendor shall incur all cost involved in obtaining an Independent Laboratory Test if the City deems necessary during the term of the Contract / Agreement / Purchase Order. The City of Fairhope reserves the right to request a demonstration of any and all items bid before making the award.

**44. PERMITS LICENSES AND CERTIFICATES**

The awarded vendor is to procure all permits, licenses, and certificates, or any approvals of plans or specifications as may be required by Federal, State, Local Laws, ordinances, rules, and regulations, for the proper execution and completion of Work covered under the Contract / Agreement / Purchase Order.

**45. PREPARATION OF BID**

All bids / proposals shall be typewritten or in ink on the form(s) prepared by the City of Fairhope. Bids / proposals prepared in pencil will not be accepted. All bids / proposals must be signed by officials of the corporation or company duly authorized to sign bids / proposals. Any bid / proposal submitted without being signed will automatically be rejected. All corrections or erasures shall be initialed and dated by the person authorized to sign quotations /bids / proposals. If there are discrepancies between unit prices quoted and extensions, the unit price will prevail.

**46. QUESTIONS / CONTACT**

Commencing with the issuance of the RFQ / ITB / RFP, or other form of solicitation, no vendor or anyone acting on a vendor's behalf, shall make direct or indirect contact with City personnel or undertake any activities or take any action to otherwise promote its quotation / bid / proposal to the City or its personnel. All communications shall be made to the contact identified in the quotation / bid / proposal documents. Violation of this requirement may, at the City's sole and absolute discretion, be grounds for disqualifying a vendor from further consideration.

**47. RECEIPT BY CITY OF FAIRHOPE**

If not otherwise stated in the order, the City of Fairhope will be said to have received goods when they have been delivered, unloaded, and placed on the agency's dock or if there is no dock, inside an accessible building, and signed for by an authorized City employee. Shipments will be checked against the receiving copy of the Purchase Order. If the purchase order requires grading certificates, USDA Stamps, or any proof of quality, such proof must accompany the shipment.

**48. REJECTION OF BIDS**

The City of Fairhope reserves the right to accept or reject any or all bids in whole or in part for any reason, to waive technicalities or informalities, or to advertise for new proposals, if, in the judgment of the awarding authority, the best interest of the City of Fairhope will be promoted thereby. Bidders may be disqualified and rejection of proposals may be recommended for any of (but not limited to) the following causes: Failure to use the bid forms furnished by the City of Fairhope, Lack of signature by an authorized representative on the bid form, Failure to properly complete the bid form and vendor compliance, Evidence of collusion among bidders, Unauthorized alteration of the bid form.

**49. RIGHT TO AUDIT**

The awarded vendor shall maintain documentation of all work performed. The awarded vendor shall make any and all documentation available to the City of Fairhope at all reasonable times, for inspections and audit by the City of Fairhope for a period of Three (3) years after expiration of the Contract / Agreement / Purchase Order.

**50. SAMPLES**

Bidders will not be required to furnish samples at the time of bid opening, unless specifically called for. The City of Fairhope reserves the right to request samples after bid opening to assist in the evaluation of proposals submitted.

**51. SAFETY MEASURES**

The awarded vendor shall take all necessary precautions for the safety of the City of Fairhope's and awarded vendor's employees at the Work site, and shall erect and properly maintain at all times, all necessary safeguards for the protection of the workmen and the public. The awarded vendor shall post signs warning against hazards in and around the Work site.

**52. SET-UP AND INSTALLATION**

Unless otherwise specified, bid / quotation to include cost of all uncrating, disposal of shipping materials, set-up, testing and initial instruction to agency personnel.

**53. SPILL CLEAN UP**

The awarded vendor shall be responsible for spillage caused by their negligence, which occurs during transit or unloading operations. The awarded vendor shall immediately report and clean up any spillage. Upon failure to do so, the awarded vendor shall remain responsible for all actual related costs.

**54. SUBSTITUTIONS**

Substitutions on a purchase order shall require the approval of the Originating Buyer. The City of Fairhope reserves the right to reject at destination and hold at the vendor's risk and expense any goods supplied by the vendor which do not conform to the specification or description embodied in the order or are inferior in any respect to the good specified. Any good bought by sample which is inferior in quality to the sample submitted by vendor will be rejected. Any goods delivered that do not meet specifications may be returned to the vendor at its expense. When a good is returned, the vendor must make immediate replacement with acceptable merchandise, or the City of Fairhope may seek remedies for default.

**55. TABULATION**

Bid results are posted on The City of Fairhope's web site: [www.FairhopeAL.gov](http://www.FairhopeAL.gov). The awarded vendor will be sent a written notification.

**56. TAXES**

Prices quoted shall be delivered prices, exclusive of all federal or state excise, sales, and manufacturer's taxes. The City will assume no transportation or handling charges other than specified in the RFQ, ITB, RFP or other form of solicitation. The City is tax exempt by law – Code of Alabama 1975.

**57. TERMINATION FOR CONVENIENCE**

Any Contract / Agreement / Purchase Order may be terminated for convenience by the City of Fairhope, in whole or in part, by written notification to the awarded vendor.

**58. TERMINATION FOR DEFAULT**

Performance of Work under the Contract / Agreement / Purchase Order Agreement may be terminated by the City of Fairhope, in whole or in part, in writing, whenever the City of Fairhope determines that the awarded vendor has failed to meet the requirements of the Contract / Agreement / Purchase Order.

**59. TERMINATION FOR NON-APPROPRIATION**

Termination for Non-appropriation – The continuation of any financial obligation beyond the current fiscal year is subject to and contingent upon sufficient funds being appropriated, budgeted, and otherwise made available by the local source, State Legislature and/or federal sources. The City of Fairhope may terminate any financial obligation, and awarded vendor waives any and all claim(s) for damages, effective immediately upon receipt of written notice (or any date specified therein) if for any reason the City of Fairhope's funding from local, State and/or federal sources is not appropriated, withdrawn or limited.

**60. TIME IS OF THE ESSENCE**

The City of Fairhope and awarded vendor agree that time is of the essence in the performance of work called for under this Contract / Agreement / Purchase Order. The awarded vendor agrees that all work will be accomplished regularly, diligently, and uninterrupted at such a rate of progress as will ensure full completion thereof within reasonable time periods.

**61. TITLE**

All titles, fees, as well as other charges, are to be paid by awarded vendor. Awarded vendor is to furnish prepaid certificate of title in the name of the City of Fairhope, Title shall change upon acceptance of delivery at the City of Fairhope approved delivery location.

**62. VENDOR LIST**

A vendor may be removed from the City of Fairhope's Bidders List if a vendor fails to respond to three (3) consecutive ITB's. A properly submitted "No Bid" is considered as a response and the vendor will receive credit for the response.

**63. WARRANTY**

The awarded vendor expressly warrants that all articles, materials, and work offered shall conform to each and every specification, drawing, sample, or other description which is furnished to or adopted by the City of Fairhope, and that it will be fit and sufficient for the purpose intended, merchantable, of good material and workmanship, and free from defects. The awarded vendor further warrants all items for a period of one year, unless otherwise stated, from the date of acceptance of the items delivered and installed or work completed. All repairs, replacements, or adjustments during the warranty period will be at the awarded vendor's sole expense. Awarded vendor will provide written warranty for all parts and labor for a period of (1) one year commencing from date of written acceptance of delivery by City of Fairhope. Awarded vendor will provide written copies of all other applicable warranties, such as, Manufacturer's warranty. Those warranties, if any, will be in addition to the awarded vendor's warranty, and the terms of which will not be altered by the awarded vendor's warranty.

**64. IMMIGRATION LAW**

The Contractor agrees that it shall comply with all of the requirements of the **Beason-Hammon Alabama Taxpayer and Citizen Protection Act, Act No 2011-535**, Alabama Code (1975) Section 31-13-1, et. Seq., (also known as the Alabama Immigration Act) see Section 31-13-9, and the provisions of said Act, including all penalties for violation thereof, are incorporated herein.

## ITEM VIII

### ALABAMA IMMIGRATION ACT CONTRACT REQUIREMENTS

#### 1.0 Background

The **Beason-Hammon Alabama Taxpayer and Citizen Protection Act, Act No 2011-535, as amended by Act No 2012-491, Code of Alabama (1975) Section 31-13-1 through Section 31-13-30** (also known as and hereinafter referred to as “the Alabama Immigration Act”) is applicable to CONTRACTs with the City of Fairhope, Alabama. All business entities entering into CONTRACTs with the City of Fairhope, Alabama will comply with the Alabama Immigration Act.

#### 2.0 Definitions

**ALIEN.** Any person who is not a citizen or national of the United States, as described in 8 U.S.C. § 1101, et seq., and any amendments thereto.

**BUSINESS ENTITY.** Any person or group of persons employing one or more persons performing or engaging in any activity, enterprise, profession, or occupation for gain, benefit, advantage, or livelihood, whether for profit or not for profit. Business entity shall include but not be limited to the following:

- a. Self-employed individuals, business entities filling articles of incorporation, partnerships, limited partnerships, limited liability companies, foreign corporations, foreign limited partnerships, foreign liability companies authorized to transact business in this state, business trusts, and any business entity that registers with the Secretary of State.
- b. Any business entity that possesses a business license, permit, certificate, approval, registration, charter, or similar form of authorization issued by the state, any business entity that is exempt by law from obtaining such a business license, an any business entity that is operating unlawfully without a business license.

**CONTRACTOR.** A person, employer, or business entity that enters into a CONTRACT to perform any service or work or to provide a certain product in exchange for valuable consideration. This definition shall include, but not be limited to, a general CONTRACTOR, SUB-CONTRACTOR, independent CONTRACTOR, CONTRACT employee, project manager, or a recruiting or staffing entity.

**EMPLOYEE.** Any person directed, allowed, or permitted to perform labor or service of any kind by an employer. The employees of an independent CONTRACTOR working for a business entity shall not be regarded as the employees of the business entity, for the purposes of this chapter. This term does not include any inmate in the legal custody of the state, a county, or a municipality.

**EMPLOYER.** Any person, firm, corporation, partnership, joint stock association, agent, manager, representative, foreman, or other person having control or custody of any employment, place of employment, or of any employee, including any person or entity employing any person for hire within the State of Alabama, including a public employer. This term shall not include the occupant of a household contracting with another person to perform casual domestic labor within the household.

**E-VERIFY.** The electronic verification of federal employment authorization program of the Illegal Immigration Reform and Immigrant Responsibility Act of 1996, P.L. 104-208, Division c, Section 403 (a); 8 U.S.C. §1324(a) and operated by the United States Department of Homeland Security, or its successor program.

**STATE-FUNDED ENTITY.** Any governmental entity of the state or a political subdivision thereof or any other entity that receives any monies from the state or a political subdivision thereof; provided, however, an entity that merely provides a service or a product to any governmental entity of the state or a political subdivision thereof, and receives compensation for the same, shall not be considered a state-funded entity.

**SUB-CONTRACTOR.** A person, business entity, or employer who is awarded a portion of an existing CONTRACT by a CONTRACTOR, regardless of its tier.

**UNAUTHORIZED ALIEN.** An alien who is not authorized to work in the United States as defined in 8 U.S.C. § 1324a (h) (3) .

### 3.0 Mandatory Clause

All CONTRACTS or CONTRACTS to which the state, a political subdivision, or state-funded entity are a party shall include the following clause:

***"By signing this CONTRACT, the CONTRACTING parties affirm, for the duration of the CONTRACT, that they will not violate federal immigration law or knowingly employ, hire for employment, or continue to employ an unauthorized alien within the state of Alabama. Furthermore, a CONTRACTING party found to be in violation of this provision shall be deemed in breach of the CONTRACT and shall be responsible for all damages resulting therefrom."***

For purposes of this section, "CONTRACT" shall mean a CONTRACT awarded by the state, any political subdivision thereof, or any state-funded entity that was competitively bid or would, if entered into by the state or an agency thereof, be required to be submitted to the CONTRACT Review Permanent Legislative Oversight Committee.

### 4.0 CONTRACTS Involving Business Entity, or Employer

As a condition for the award of any CONTRACT, grant, or incentive by the state, any political subdivision thereof, or any state-funded entity to a business entity or employer that employs one or more employees, the business entity or employer shall not knowingly employ, hire for employment, or continue to employ an unauthorized alien within the State of Alabama.

As a condition for the award of any CONTRACT, grant, or incentive by the state, any political subdivision thereof, or any state-funded entity to a business entity or employer that employs one or more employees within the state of Alabama, **the business entity or employer shall provide documentation establishing that the business entity or employer is enrolled in the E-Verify program.** During the performance of the CONTRACT, the business entity or employer shall participate in the E-Verify program and shall verify every employee that is required to be verified according to the applicable federal rules and regulations.

### 5.0 CONTRACTS Involving Subcontracting

Any SUB-CONTRACTOR on a project paid for by CONTRACT, grant, or incentive by the state, any political subdivision thereof, or any state-funded entity shall not knowingly employ, hire for employment, or continue to employ an unauthorized alien within the State of Alabama and shall also enroll in the E-Verify program prior to performing any work on the project. Furthermore, during the performance of the CONTRACT, the SUB-CONTRACTOR shall participate in the E-Verify program and shall verify every employee that is required to be verified according to the applicable federal rules and regulations. This subsection shall only apply to SUB-BIDDERS performing work on a project subject to the provisions of this section and not to collateral persons or business entities hired by the SUB -CONTRACTOR.

### 6.0 Proof of E-Verify documentation will be in the form of a copy of the signed Memorandum Of Understanding (MOU) generated upon completion of the E-Verify program.

**END OF ALABAMA IMMIGRATION ACT CONTRACT REQUIREMENTS**

ITEM IX

INVITATION SUMMARY

**Bid No. 24-020-2024-PWI-001  
Pine Street One-Way Conversion and Parking Project  
Public Works Project No. 2024-PWI 001**

Bid Name:	<b>BID 24-020-2024-PWI-001 Pine Street One-Way Conversion and Parking Project</b>
Issue Date:	January 12, 2024
Certificate of Insurance Requirements:	See Item V
Non-Mandatory Pre-Bid Meeting:	Tuesday, January 30, 2024, 10:00 A.M.
Deadline for Questions Date:	Thursday, February 1, 2024, 11:00 A.M.
<b>Bid Due Date:</b>	Thursday, February 8, 2024, 10:00 A.M.
City Internet Site:	<a href="http://www.FairhopeAL.gov">www.FairhopeAL.gov</a>
<b>SEALED Bid Response</b> Copies to submit:	One (1) Original Paper Copy
Purchasing Department Contact for questions:	<a href="mailto:Purchasing@FairhopeAL.gov">Purchasing@FairhopeAL.gov</a> (251) 928-8003

END OF INVITATION SUMMARY



**ITEM X**  
**BID BOND INFORMATION**

Bids shall be accompanied by a Bid Security equal to 5% (percent) of the bid price, but in no event more than \$10,000.00. Bid Security shall be in the form of a Bid Bond or a cashier's check payable to The City of Fairhope. All bonds and/or cashier's check will be made payable to the City of Fairhope for an amount not less than five (5) percent of the City's or its engineers or architects estimated cost of the Project or of the total bid in the proposal, but in no event more than \$10,000.00.

**Return of Bid Bonds:** All bid bonds, except those of the three lowest bona fide bidders, will be returned immediately after bids have been checked, tabulated and the relation of the bids established. The bid bonds of the three lowest bidders may be retained and if so, will be returned as soon as the contract bonds and the contract documents of the successful bidder have been approved and properly executed.

In the event it is necessary to defer a contract award for longer than fifteen (15) days, after opening of bids, then all bid bonds, except that of the potential successful bidders will be returned.

Award of the contract will be made within the time specified after the opening of bids. In the event no award is made within such time, all bids may be rejected, and all bonds returned.

Provided; however, the potentially successful bidder may enter into a written agreement with the City for an extension of time for consideration of its bid, in which case, the bidder's bond shall remain in full force and effect, or the City may permit said bidder to substitute a satisfactory surety for the cashier's check if submitted as a guaranty to the bid bond.

**Forfeiture of Bid Bonds:** Should the successful bidder or bidders to whom a contract is awarded fail to execute a contract(s) and furnish acceptable contract securities and evidence of insurance, as required, within thirty (30) days after the prescribed forms have been presented to him/her, the City may retain from the proposal guaranty, if it is a cashier's check or recovered from the principal or the sureties, if the guaranty is a bid bond, the difference between the amount of the contract as awarded, and the amount of the proposals of the new lowest bidder. If no other bids are received, the full amount of the proposal guaranty may be so retained and recovered as liquidated damages for such default. Any sum so retained or recovered shall be the property of the awarding authority.

**END OF BID BOND INFORMATION**

**ITEM X**  
**BID BOND**

The PRINCIPAL (Bidder's name and address)

The OWNER  
City of Fairhope  
P.O. Drawer 429  
Fairhope, Al 36533

The PROJECT for which the Principal's Bid is submitted: (Project name as it appears in the Bid Documents)

**PROJECT NO.**  
**PROJECT NAME:**

KNOW ALL MEN BY THESE PRESENTS, that we, the undersigned Principal and Surety, jointly and severally, hereby bind ourselves, our heirs, executors, administrators, successors, and assigns to the OWNER in the PENAL SUM of five percent (5%) of the amount of the Principal's bid, but in no event more than TEN THOUSAND DOLLARS (\$10,000.00).

THE CONDITION OF THIS OBLIGATION is that the Principal has submitted to the OWNER the attached bid, which is incorporated herein by reference, for the Project identified above.

NOW, THEREFORE, if, within the terms of the Bid Document, the OWNER accepts the Principal's bid and the Principal thereafter either:

- (a) executes and delivers a Construction Contract with the required Performance and Payment Bonds (each in the for contained in the Bid Documents and properly completed in accordance with the bid) and delivers evidence of insurance as prescribed in the Bid Documents, or fails to execute and deliver such Construction Contract with such Bonds and evidence of insurance, but pays the OWNER the difference, not to exceed the Penal Sum of this Bond, between the amount of the Principal's Bid and the larger amount for which the OWNER may award a Construction Contract for the same Work to another Bidder, then, this obligation shall be null and void, otherwise it shall remain in full force and effect.

The Surety, for value received, hereby stipulates and agrees that the obligation of the Surety under this Bond shall not in any manner be impaired or affected by any extension of the time within which the OWNER may accept the Principal's bid, and the Surety does hereby waive notice of any such extension.

SIGNED AND SEALED this \_\_\_\_\_ day of \_\_\_\_\_, 202\_\_\_\_\_.

\_\_\_\_\_  
**(Principal (Company))**  
**ATTEST** \_\_\_\_\_ By \_\_\_\_\_

\_\_\_\_\_  
**SURETY**  
**ATTEST** \_\_\_\_\_  
\_\_\_\_\_  
**Surety Company**  
\_\_\_\_\_  
Print Name and Title

**CORPORATION**  
\_\_\_\_\_  
Name of Corporation, Partnership, or Joint Venture  
Business Mailing Address: \_\_\_\_\_  
\_\_\_\_\_  
email \_\_\_\_\_ phone \_\_\_\_\_

BY: \_\_\_\_\_  
(Signature of Officer Authorized to sign Bids  
and Contracts for the Firm)

\_\_\_\_\_  
(Position or Title)

\_\_\_\_\_  
(General Contractor's License Number)  
vendors)

\_\_\_\_\_  
Foreign Corporation Entity Id (Required of out-of-state-

Attest:

\_\_\_\_\_  
(Secretary)

\_\_\_\_\_  
(Name of State under the laws of which incorporated)

\_\_\_\_\_  
(Name of Surety)

BY: \_\_\_\_\_  
(Attorney in Fact)

**ITEM XI  
PERFORMANCE BOND**

KNOW ALL MEN: That \_\_\_\_\_ as Principal,  
(name & address of legal title of contractor)

and \_\_\_\_\_ and  
(name & address of legal title of one or more sureties)

\_\_\_\_\_  
(name & address of legal title of one or more sureties)

Hereinafter called the Surety or Sureties, are held and firmly bound unto the CITY OF FAIRHOPE, ALABAMA, hereinafter called the OWNER in the sum of \_\_\_\_\_ Dollars (\$ \_\_\_\_\_), for the payment whereof the Principal and the Surety or Sureties bind themselves, their heirs, executors, administrators, successors, and assigns, jointly and severally, firmly by these presents.

WHEREAS, The Principal has, by means of a written agreement, dated \_\_\_ / \_\_\_ / \_\_\_, entered into a contract with the OWNER for **Bid 24-020-2024-PWI-001 Pine Street One-Way Conversion and Parking Project**, which agreement is by reference made a part hereof.

NOW THEREFORE, the conditions of this obligation is such that if the Principal shall faithfully perform the contract on his part, and satisfy all claims and demands, incurred for the same, and shall fully indemnify and save harmless the OWNER from all cost and damage which he may suffer by reason of failure to do so, and shall reimburse and repay OWNER all outlay and expense which the OWNER may incur in making good for any such default thence this obligation shall be null and void: otherwise, it shall remain in full force and effect.

PROVIDED, HOWEVER, that no suit, action or proceedings, by reason of any default whatever be brought on his Bond after twelve months from the day on which the final payment under the Contract falls due.

PROVIDED, further, that the said surety or sureties, for value received hereby stipulate and agree that no change, extension of time, or addition to the terms of the Contract or to the work to be performed thereunder of the specifications thereof shall in any way effect their obligations on this bond, and they do hereby waive notice of any such change, extension of time, alteration or addition to the terms of the contract, or to the work, or to the Specifications.

WITNESS our hands this \_\_\_\_\_ day of \_\_\_\_\_, 202\_\_\_\_.

**IF INDIVIDUAL**

\_\_\_\_\_, Doing Business As, \_\_\_\_\_  
(SIGNATURE of Individual Bidder) (Business Name)

Business Mailing Address \_\_\_\_\_

**IF CORPORATION**

\_\_\_\_\_  
(Name of Corporation, Partnership, or Joint Venture)

Business Mailing Address \_\_\_\_\_

By: \_\_\_\_\_  
(SIGNATURE of officer authorized to sign Bids and Contracts for the company) (Position or Title)

ATTEST:

\_\_\_\_\_  
(Secretary) (Name of State of incorporation)

\_\_\_\_\_  
(Name of Surety) By: \_\_\_\_\_  
(Attorney in Fact)

**ITEM XII  
LABOR AND MATERIAL BOND**

**KNOWN ALL MEN BY THESE PRESENTS**, that we, \_\_\_\_\_ (hereinafter called the "Contractor") of \_\_\_\_\_ as principal and (hereinafter called the "Surety"), as Surety, do hereby acknowledge ourselves indebted and firmly bound and held unto the City of Fairhope, Alabama, (hereinafter called the "**City**"), a municipal corporation, existing under and by virtue of the Laws of the State of Alabama, for the use and benefit of those entitled thereto, in the penal sum of \_\_\_\_\_ (\$\_\_\_\_\_) for the payment of which well and truly to be made in lawful money of the United States, we do hereby bind ourselves, or successors, assigns and personal representatives, jointly and severally, firmly by these presents.

BUT THE CONDITION OF THE FOREGOING OBLIGATION OR BOND IS THIS:

**WHEREAS**, the **City** has entered into a certain written contract with said Contractor for **Bid No. 24-020-2024-PWI-001 Pine Street One-Way Conversion and Parking Project**, in accordance with contract documents heretofore on file in the Office of the **City of Fairhope** at the price of, to-wit: \_\_\_\_\_ (\$\_\_\_\_\_) as more fully appears in said written Contract bearing date of \_\_\_\_\_, 20\_\_\_\_, which Contract is hereby referred to and made a part hereof to the same extent as if set out herein in full.

**NOW, THEREFORE**, if said Principal and all subcontractors to whom any portion of the work provided for in said contract is sublet and all assignees of said Principal and of such subcontractors shall promptly make payment to all persons supplying him or them with labor, foodstuffs, or supplies for or in the prosecution of the work provided for in such contract, or in any amendment or extension of or addition to said contract, and for the payment of reasonable attorney's fees, incurred by the claimant or claimants in suits on said bond, then the above obligation shall be void; otherwise, it shall remain in full force and effect.

**PROVIDED**, however, that this bond is subject to the following conditions and limitations:

(a) Any person, firm or corporation that has furnished labor, foodstuffs, or supplies for or in the prosecution of the work provided for in said contract, payment for which has not been made, shall have a direct right of action in his or their name or names against the principal and surety on this bond, which right of action shall be asserted in a proceeding, instituted in the county in which the work provided for in said contract is to be performed and in any county in which said Principal or Surety does business. Such right of action shall be asserted in a proceeding instituted in the name of the claimant or claimants for his or their use and benefit against said Principal and Surety or either of them (but not later than one year after the final settlement of said Contract) in which action such claim or claims shall be adjudicated and judgment rendered thereon.

(b) In addition to any other legal mode of service, service of summons and other process in suits on this bond brought in Baldwin County may be had on the Principal or the Surety in accordance with Title 27, Chapter 3, Section 24 of the Ala. Code (1975) by serving a copy of the summons and complaint or other pleading or process, with the Commissioner of Insurance of the State of Alabama or his/ her designee and the Principal and Surety agree to be bound by such mode of service above described and consents that such service shall be the same as personal service on the Principal or Surety.

(c) The Surety shall not be liable hereunder for any damages or compensation recoverable under any workmen's compensation or employer's liability statute.

(d) In no event shall the Surety be liable for a greater sum than the penalty of this bond, or subject to any suit, action or proceeding thereon that is instituted later than one year after the final settlement of said contract.

(e) This bond is given pursuant to the terms of Title 39, Chapter 1, Section 1 of the Ala. Code (1975), and all the provisions of law with reference to this character of bond as set forth in said section or as may hereinafter be enacted are hereby made a part hereof to the same extent as if set out herein in full.

**IN WITNESS WHEREOF**, the said Contractor has hereunder affixed its signature and said Surety has hereunto caused to be affixed its corporate signature and seal, by its duly authorized officers on the \_\_\_\_ day of \_\_\_\_\_, 20\_\_\_\_.

\_\_\_\_\_  
Principal

By: \_\_\_\_\_

\_\_\_\_\_  
Title

\_\_\_\_\_  
Surety

ATTEST:

By: \_\_\_\_\_

\_\_\_\_\_  
Title

# ITEM XIII



## CITY OF FAIRHOPE CLOSEOUT DOCUMENTS

CONSENT OF SURETY COMPANY TO FINAL PAYMENT

CONTRACTOR'S AFFIDAVIT OF PAYMENT

FINAL RELEASE OF LIENS

NOTICE OF COMPLETION ADVERTISEMENT



**CITY OF FAIRHOPE  
CONSENT OF SURETY COMPANY TO FINAL PAYMENT**

**COF PROJECT NO:** \_\_\_\_\_

**COF PROJECT NAME:** \_\_\_\_\_

**OWNER:** **City of Fairhope**  
**P.O. Drawer 429**  
**Fairhope, AL 36533**

**CONTRACTOR:** \_\_\_\_\_  
\_\_\_\_\_  
\_\_\_\_\_

In accordance with the provision of the Contract between the OWNER and the CONTRACTOR as indicated above, the \_\_\_\_\_, Surety Company on bond of \_\_\_\_\_ CONTRACTOR, hereby approved the final payment to the CONTRACTOR and agrees that final payment to the CONTRACTOR shall not relieve the Surety Company of any of its obligations to the City of Fairhope as set forth in said Surety Company's bond dated the \_\_\_\_\_ day of \_\_\_\_\_, 202\_\_\_\_.

**IN WITNESS WHEREOF**

The Surety Company has hereunto set its hand this \_\_\_\_ day of \_\_\_\_\_, 202\_\_\_\_.

ATTEST  
(Seal)

Surety Company

\_\_\_\_\_  
Signature of Authorized Representative

\_\_\_\_\_  
Title





**CITY OF FAIRHOPE  
CONTRACTOR'S AFFIDAVIT OF PAYMENT  
OF CLAIMS & DEBTS**

COF PROJECT NO: \_\_\_\_\_

COF PROJECT NAME: \_\_\_\_\_

OWNER: **City of Fairhope  
P.O. Drawer 429  
Fairhope, AL 36533**

CONTRACTOR: \_\_\_\_\_  
\_\_\_\_\_  
\_\_\_\_\_

STATE OF: \_\_\_\_\_

COUNTY OF: \_\_\_\_\_

The undersigned hereby certified that, except as listed below, he has paid in full or otherwise satisfied all obligations for all materials and equipment furnished, for all work, Labor and services performed, and for all known indebtedness and claims against the CONTRACTOR for damages arising in any manner in connection with the performance of the Contract referenced above for which the OWNER or his property might in any way be held responsible.

EXCEPTION: (If none, write NONE) \_\_\_\_\_

\_\_\_\_\_  
CONTRACTOR

By: \_\_\_\_\_ Title: \_\_\_\_\_

Subscribed and sworn to and before me this \_\_\_ day of \_\_\_\_\_, 202\_\_.

\_\_\_\_\_  
NOTARY PUBLIC

My Commission expires \_\_\_/\_\_\_/\_\_\_



**CITY OF FAIRHOPE  
FINAL RELEASE OF LIENS**

KNOW ALL MEN BY THESE PRESENTS: In consideration of, and contingent upon the receipt of total payments in the amount of \_\_\_\_\_

Under and pursuant to the following contract:

**COF PROJECT NO:** \_\_\_\_\_

**COF PROJECT NAME:** \_\_\_\_\_

The undersigned hereby releases \_\_\_\_\_, its officers, agents, and employees, of and from all liabilities, obligations, and claims whatsoever in law and in equity under or arising out of said contract. We do hereby certify that all labor, materials, equipment, supplies, etc. for this project have been paid in full and there is no outstanding indebtedness.

IN WITNESS WHEREOF, this release has been executed this \_\_\_\_\_ day of \_\_\_\_\_, 202\_\_.

\_\_\_\_\_  
CONTRACTOR

\_\_\_\_\_  
By: SIGNATURE

\_\_\_\_\_  
PRINTED NAME

\_\_\_\_\_  
Title

**STATE OF ALABAMA  
COUNTY OF BALDWIN**

I, the undersigned authority, a Notary Public in and for said County and State, hereby certify that \_\_\_\_\_, whose name is signed to the foregoing instrument and who is known to me, acknowledged before me on this day that, being informed of the contents of the within instrument, he executed the same voluntarily on the day the same bears date.

Given under my hand and seal on this the \_\_\_\_\_ day of \_\_\_\_\_, 202\_\_.

\_\_\_\_\_  
NOTARY PUBLIC

My Commission Expires: \_\_\_/\_\_\_/\_\_\_



**CITY OF FAIRHOPE  
NOTICE OF COMPLETION LEGAL NOTICE**

**Bid Number:** \_\_\_\_\_

**Bid Name:** \_\_\_\_\_

In accordance with Chapter 1, Title 39, Code of Alabama, 1975, for contracts over \$50,000 and less than \$500,000, Notice is hereby given that

\_\_\_\_\_, CONTRACTOR, has completed the Contract for the above referenced bid for the City of Fairhope, Alabama, OWNER, and has made request for final settlement of said Contract. Any claims for labor, materials or otherwise in connection with this project should be itemized, notarized, and presented to:

**OWNER:**

**CITY OF FAIRHOPE  
555 South Section Street  
P.O. Drawer 429  
Fairhope, AL 36533**

On or before (30 days) or same will be barred.

**Contractor:**

Dates ad was run (one time): \_\_\_\_\_

Newspapers in which ad run (dates): \_\_\_\_\_

**Contractor to provide Proof of Publication of the Notice of Completion to the City by affidavit of the publisher and a printed copy of the notice published.**

# PINE STREET ONE-WAY CONVERSION & PARKING

## CITY OF FAIRHOPE - PUBLIC WORKS DEPARTMENT

JANUARY 2024



### INDEX TO SHEETS

<u>SHEET</u>	<u>DESCRIPTION</u>
1	Title
2	Overall Plan and Layout
3	Demolition Plan
4	Drainage & Street Plan & Profile
5	Cross Sections - STA 00+00 to 01+00
6	Cross Sections - STA 01+50 to 02+50
7	Paver Parking Details
8	Typical Cross Section & Details
9	Drainage Outlet Box Details
10	Sidewalk Details & Notes



### MAYOR

Sherry Sullivan

### CITY COUNCIL

Kevin G. Boone

Corey Martin

Jack Burrell, ACOMO

Jimmy Conyers

Jay Robinson

### CITY ENGINEER

Richard D. Johnson, PE

### PUBLIC WORKS DIRECTOR

George Ladd

### CITY CLERK

Lisa A. Hanks, MMC

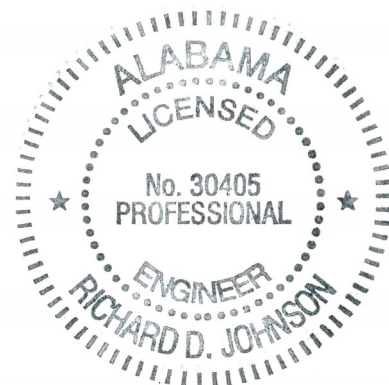

*Richard D. Johnson*  
 Richard D. Johnson  
 AL. REG. NO. 30405  
 Project Engineer

01-03-2024  
 Date

**Project: 2024-PWI 001  
 Bid Set Drawings**

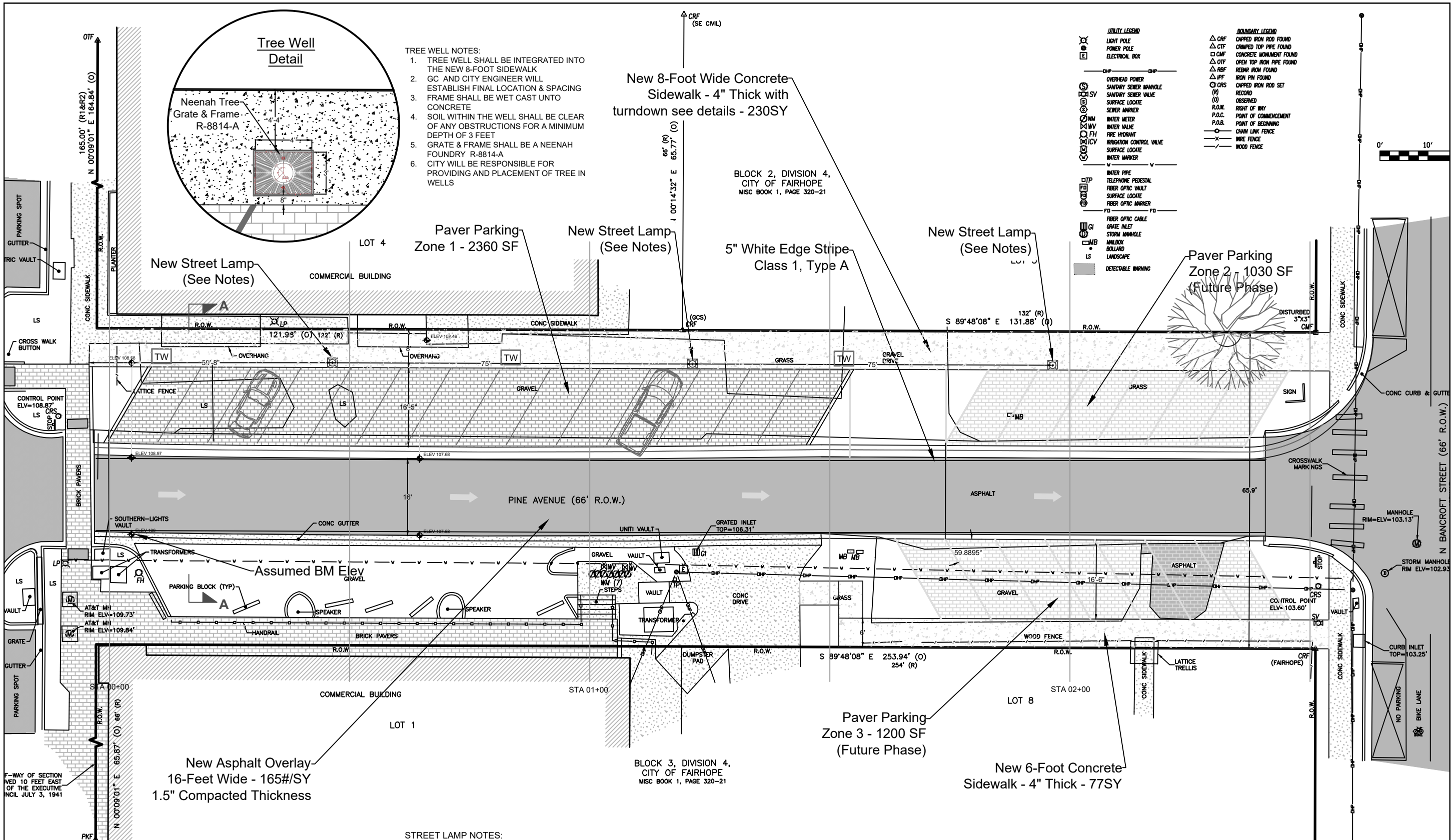

- TREE WELL NOTES:**
1. TREE WELL SHALL BE INTEGRATED INTO THE NEW 8-FOOT SIDEWALK
  2. GC AND CITY ENGINEER WILL ESTABLISH FINAL LOCATION & SPACING
  3. FRAME SHALL BE WET CAST UNTO CONCRETE
  4. SOIL WITHIN THE WELL SHALL BE CLEAR OF ANY OBSTRUCTIONS FOR A MINIMUM DEPTH OF 3 FEET
  5. GRATE & FRAME SHALL BE A NEENAH FOUNDRY R-8814-A
  6. CITY WILL BE RESPONSIBLE FOR PROVIDING AND PLACEMENT OF TREE IN WELLS

- STREET LAMP NOTES:**
1. CONTRACTOR SHALL PROVIDE 3 - 24"x24" BLOCK OUTS WITHIN THE NEW SIDEWALK AS SHOWN
  2. CITY ELECTRIC DEPARTMENT WILL RUN ALL CONDUITS PRIOR TO CONTRACTOR'S PLACEMENT OF SIDEWALK
  3. CITY ELECTRIC DEPARTMENT WILL PROVIDE AND INSTALL NEW STREET LAMPS
  4. CONTRACTOR SHALL BE RESPONSIBLE FOR COORDINATING ALL WORK TO AVOID CONFLICTS

**UTILITY LEGEND**

- Light Pole
- Power Pole
- Electrical Box
- Overhead Power
- Sanitary Sewer Manhole
- Sanitary Sewer Valve
- Surface Locate
- Water Meter
- Water Valve
- Fire Hydrant
- Irrigation Control Valve
- Water Marker
- Water Pipe
- Telephone Pedestal
- Fiber Optic Vault
- Surface Locate
- Fiber Optic Marker
- Fiber Optic Cable
- Grate Inlet
- Storm Manhole
- Mailbox
- Bollard
- Landscape
- Detectable Warning

**BOUNDARY LEGEND**

- CRF: Capped Iron Rod Found
- CIF: Capped Top Pipe Found
- CMF: Concrete Monument Found
- OTF: Open Top Iron Pipe Found
- RFI: Rebar Iron Found
- IFP: Iron Pin Found
- CRS: Capped Iron Rod Set
- R: Record
- O: Observed
- R.O.W: Right of Way
- P.O.C: Point of Commencement
- P.O.B: Point of Beginning
- CL: Chain Link Fence
- W: Wire Fence
- WF: Wood Fence

PINE AVENUE - ONE-WAY CONVERSION		
City of Fairhope, Public Works		
Date: Nov. 1, 2023	Drawn By: R.D. Johnson, PE	Overall Plan
Scale: 1" = 20'	2024-PWI 001	Page 2 of 10



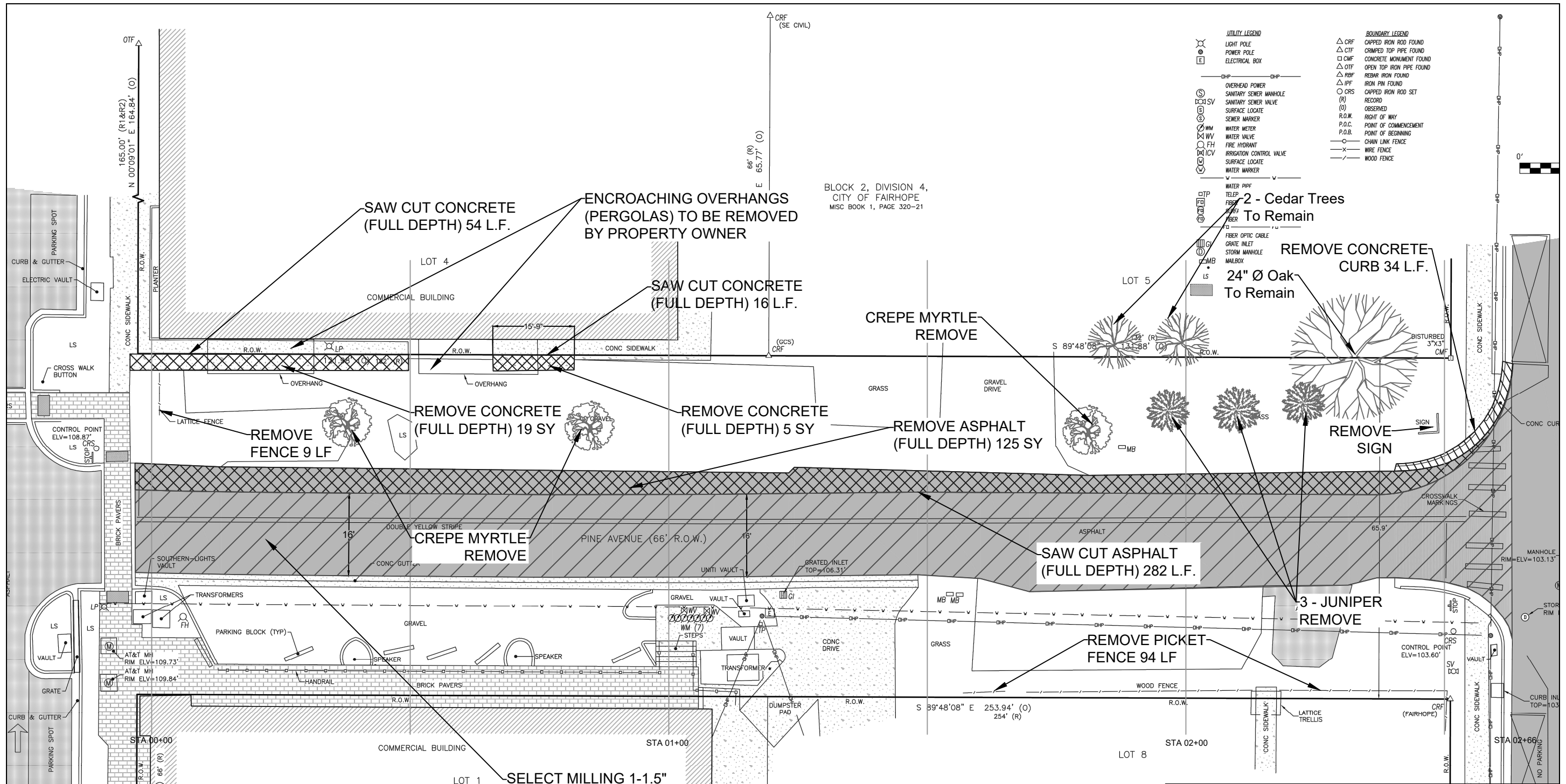

- UTILITY LEGEND**
- LIGHT POLE
  - POWER POLE
  - ELECTRICAL BOX
  - DHP — OVERHEAD POWER
  - SSV SANITARY SEWER VALVE
  - SV SURFACE VALVE
  - SM SURFACE MANHOLE
  - WM WATER METER
  - WV WATER VALVE
  - FH FIRE HYDRANT
  - ICV IRRIGATION CONTROL VALVE
  - SURFACE LOCATE
  - WATER MARKER
  - TELEF TELEPHONE
  - FIBER FIBER
  - FIBER OPTIC CABLE
  - GRATE INLET
  - STORM MANHOLE
  - MAILBOX
- BOUNDARY LEGEND**
- △ CRF CAPPED IRON ROD FOUND
  - △ CTF CRAMPED TOP PIPE FOUND
  - CMF CONCRETE MONUMENT FOUND
  - △ OTF OPEN TOP IRON PIPE FOUND
  - △ RIF REBAR IRON FOUND
  - △ IPF IRON PIN FOUND
  - CRS CAPPED IRON ROD SET
  - (R) RECORD
  - (O) OBSERVED
  - R.O.W. RIGHT OF WAY
  - P.O.C. POINT OF COMMENCEMENT
  - P.O.B. POINT OF BEGINNING
  - CHAIN LINK FENCE
  - WIRE FENCE
  - WOOD FENCE

<b>PINE AVENUE - ONE-WAY CONVERSION</b>		
City of Fairhope, Public Works		
Date: Nov. 1, 2023	Drawn By: R.D. Johnson, PE	Demo Plan
Scale: 1" = 20'	2024-PWI 001	Page 3 of 10

**MILLING NOTE:** Full width to be milled, 1" to 1.5" (Max) - milling shall be field verified in order to maintain cross slope and tie in with curbing.

- DEMO NOTES**
1. SAW CUTTING & REMOVAL OF EXISTING ASPHALT:
    - 1.1. MAINTAIN A STRAIGHT CUT EAST TO WEST (CAN SERVE AS FORM EDGE TO NEW CONCRETE CURB/GUTTER)
    - 1.2. MARK CUT LINE PRIOR TO ANY CUTTING TO ENSURE 16-FOOT ROADWAY WIDTH
    - 1.3. PRIOR TO SAW CUTTING - CUT LINE SHALL REQUIRE APPROVAL OF CITY ENGINEER
  2. SAW CUTTING & REMOVAL OF EXISTING CONCRETE WALKWAYS:
    - 2.1. CONTRACTOR SHALL BE RESPONSIBLE FOR LOCATING & MAINTAINING R.O.W. LINE FOR PURPOSES OF ACCURATE CUTTING & DEMOLITION
  3. CURBING NORTHEAST OF INTERSECTION OF PINE AND BANCROFT TO CUT AND REMOVED NEATLY - NEW 30" VALLEY CURB SHALL TIE INTO
  4. FENCE REMOVAL - SHALL BE AT THE DIRECTION OF THE CITY ENGINEER
  5. DEMO DEBRIS - CONTRACTOR SHALL BE ALLOWED TO DISPOSE OF IN THE CITY'S C&D LANDFILL (555 S. SECT ST.) AT NO COST - GC IS RESPONSIBLE FOR HAULING ALL DEBRIS

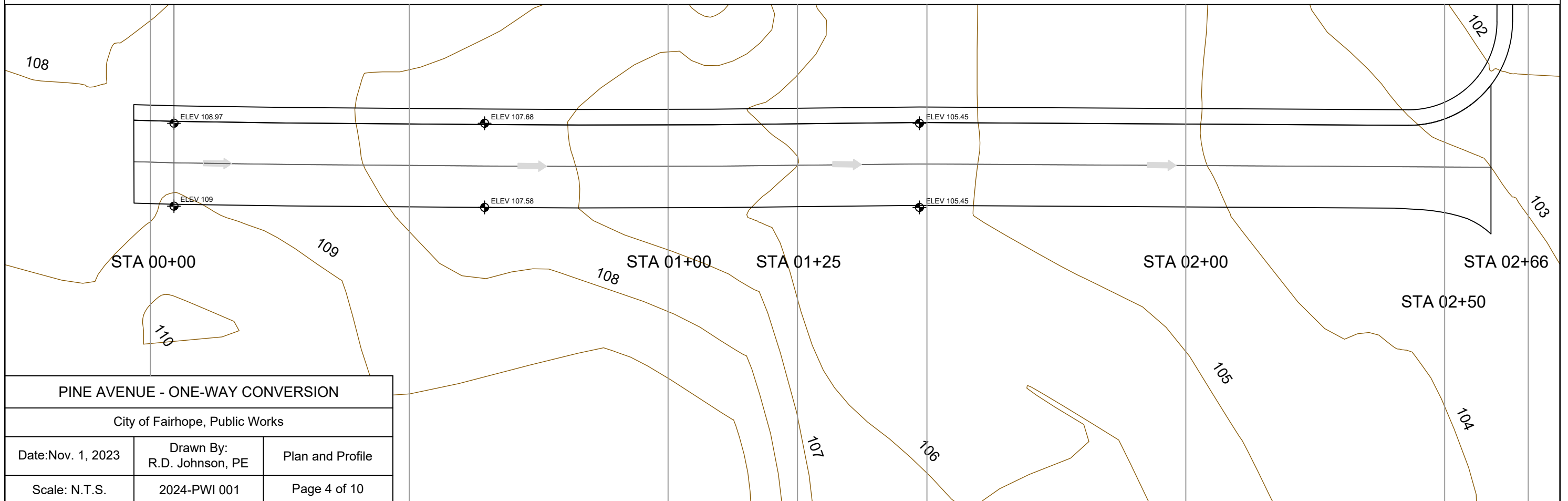
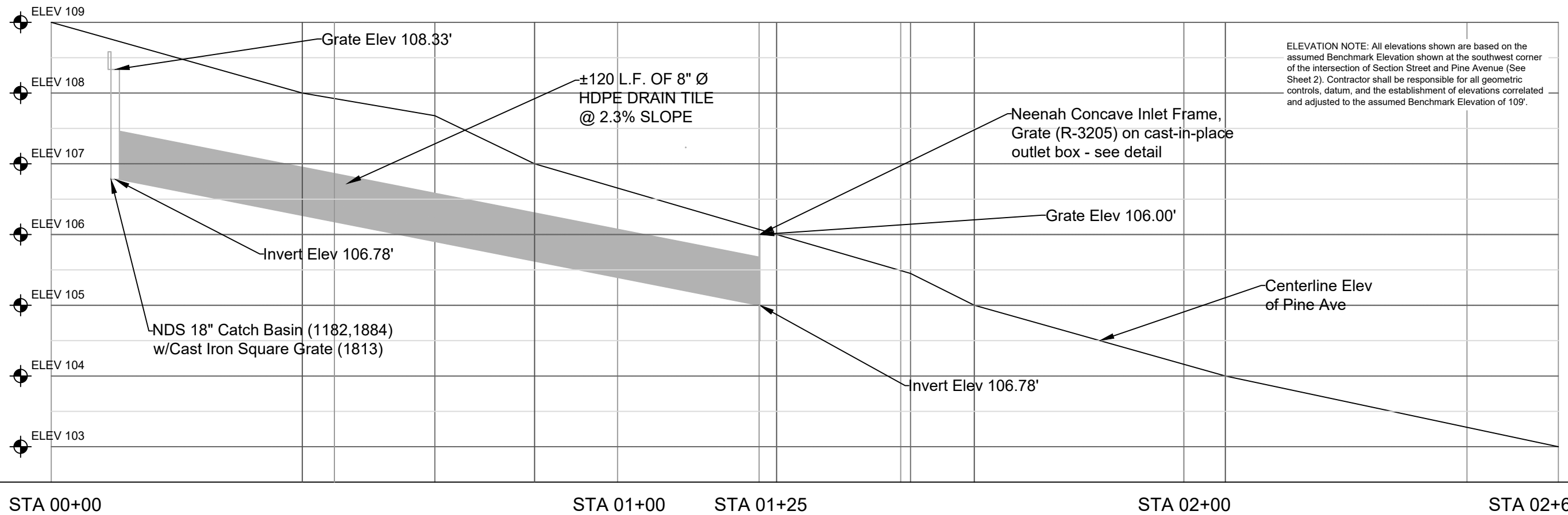

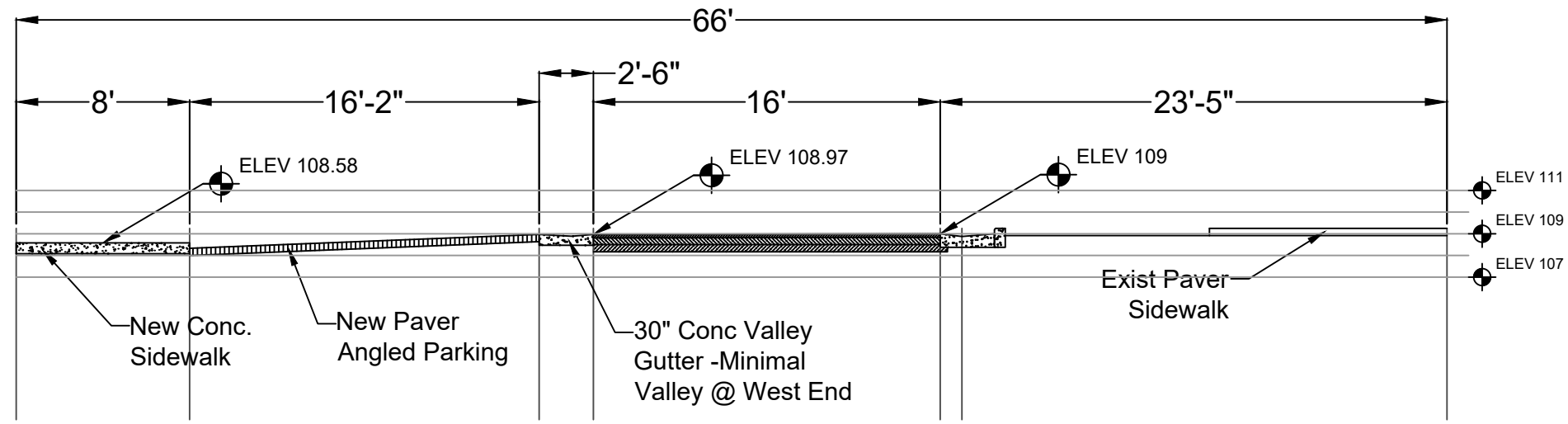

**CROSS SECTION  
STA 00+00**

R.O.W.

R.O.W.

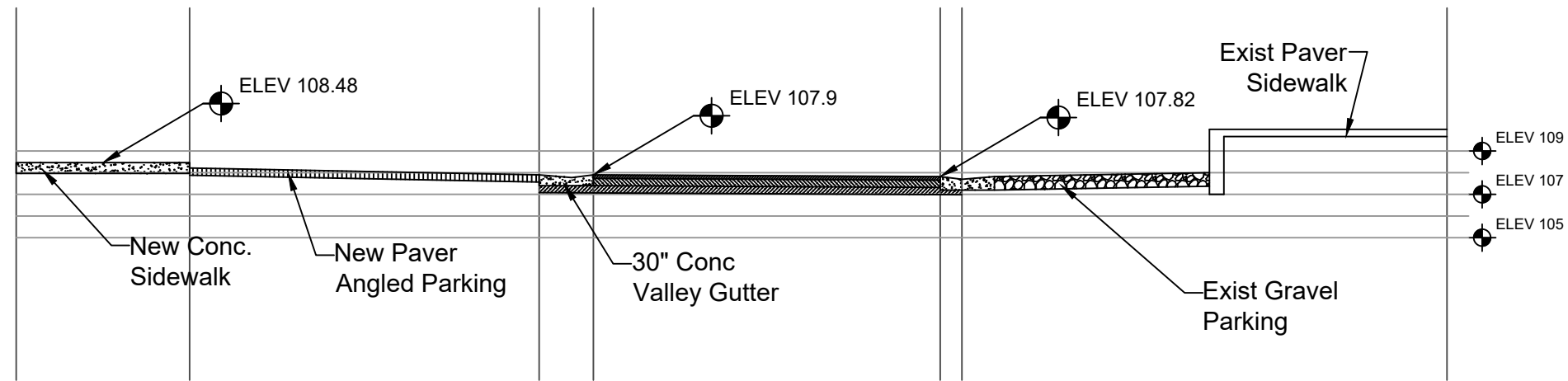

**CROSS SECTION  
STA 00+50**

R.O.W.

R.O.W.

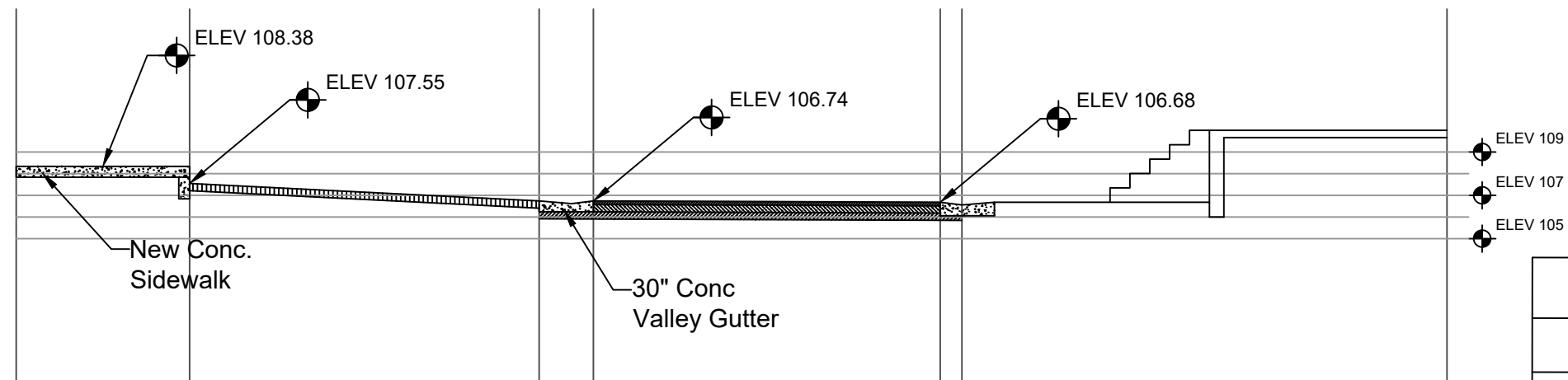

**CROSS SECTION  
STA 01+00**

R.O.W.

R.O.W.

<b>PINE AVENUE - ONE-WAY CONVERSION</b>		
City of Fairhope, Public Works		
Date: Nov. 1, 2023	Drawn By: R.D. Johnson, PE	STA Cross Sections 00+00 to 01+00
Scale: N.T.S.	2024-PWI 001	Page 5 of 10



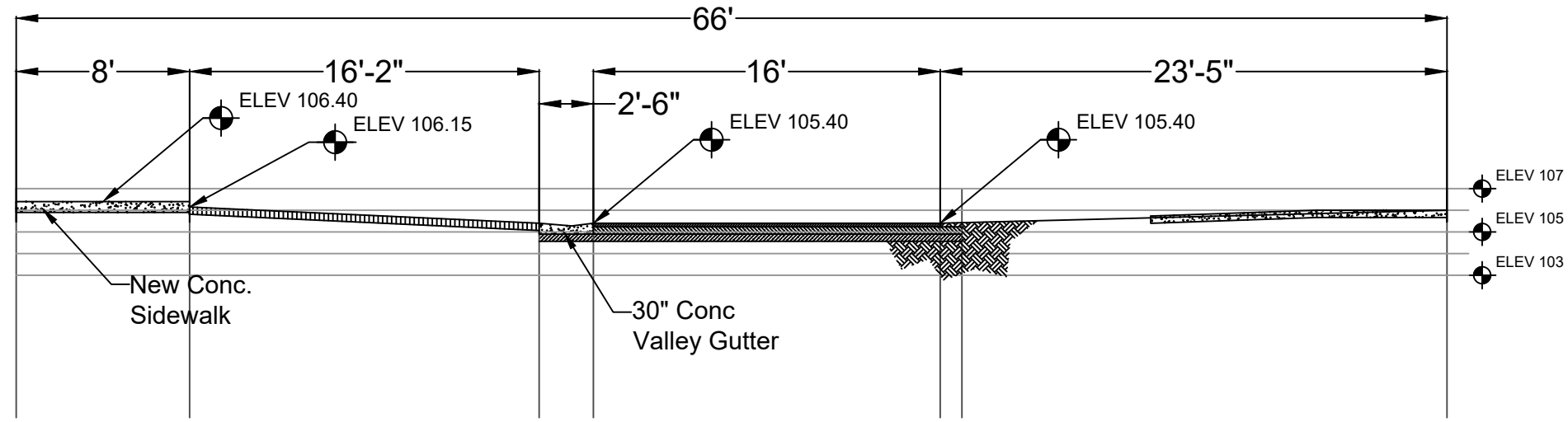

**CROSS SECTION  
STA 01+50**

R.O.W.

R.O.W.

\* NOTE: FINAL SIDEWALK ELEVATION SHALL BE DETERMINED IN THE FIELD BASED ON GRADE & DRAINAGE

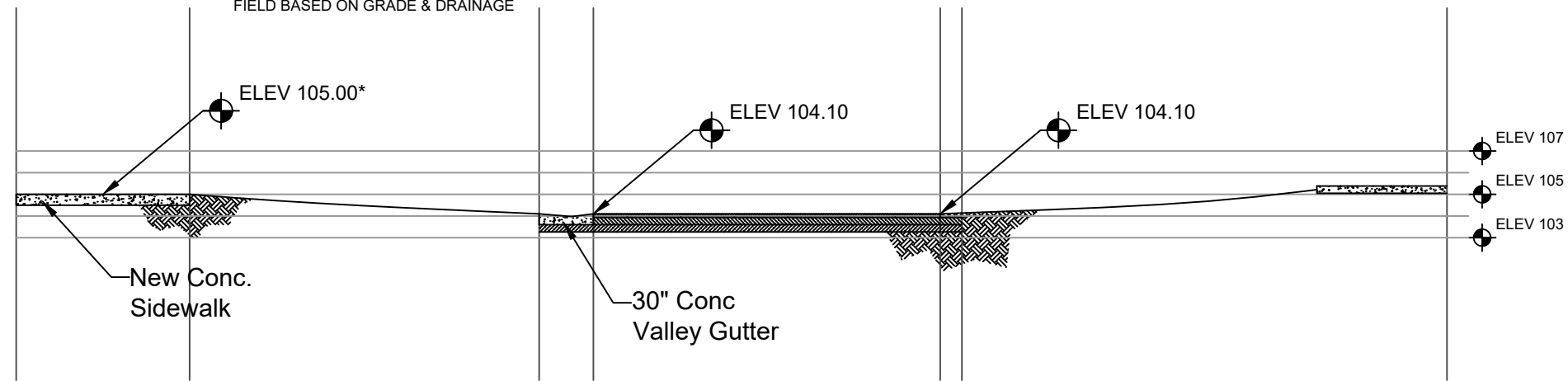

**CROSS SECTION  
STA 02+00**

R.O.W.

R.O.W.

\* NOTE: FINAL SIDEWALK ELEVATION SHALL BE DETERMINED IN THE FIELD BASED ON GRADE & DRAINAGE

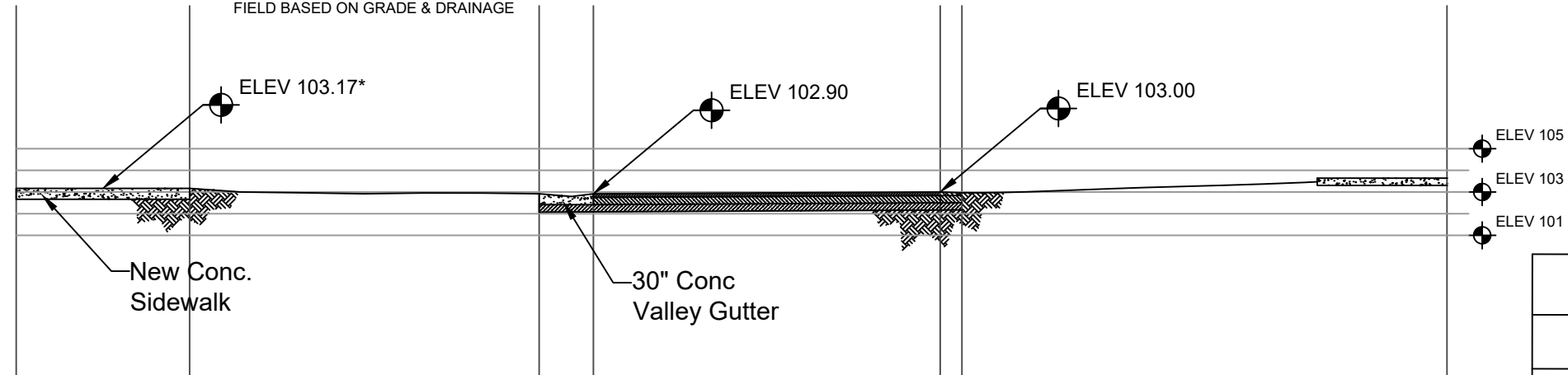

**CROSS SECTION  
STA 02+50**

R.O.W.

R.O.W.

**PINE AVENUE - ONE-WAY CONVERSION**

City of Fairhope, Public Works

Date: Nov. 1, 2023

Drawn By:  
R.D. Johnson, PE

STA Cross Sections  
01+50 to 02+50

Scale: N.T.S.

2024-PWI 001

Page 6 of 10



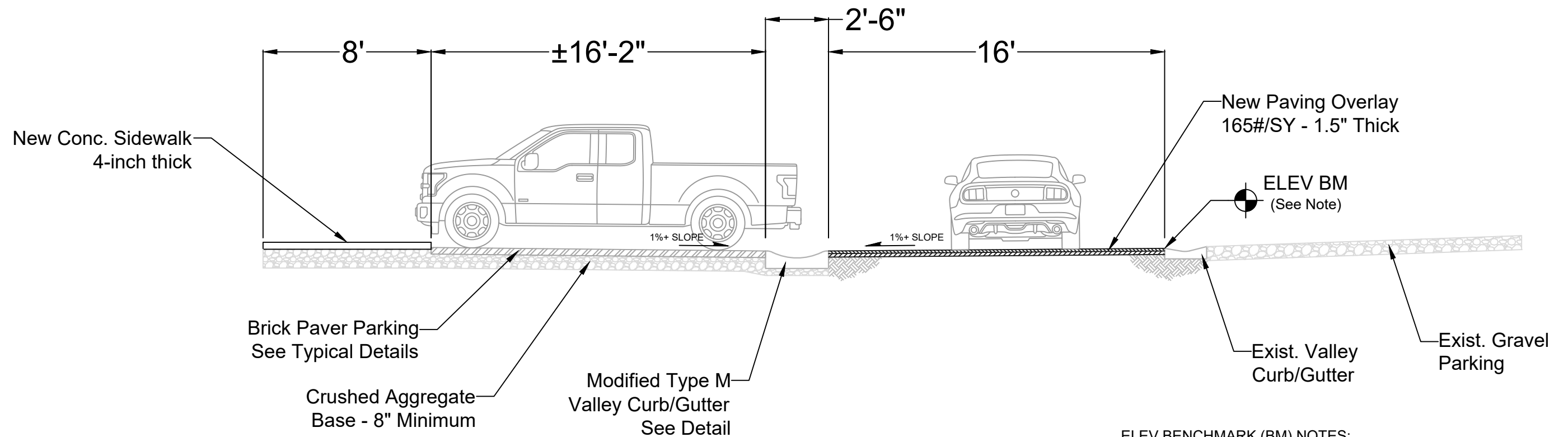

- ELEV BENCHMARK (BM) NOTES:**
1. The toe of existing valley gutter shall serve as the benchmark to set the starting elevation of the 36" modified type M gutter
  2. There shall be positive drainage (S-N) across the narrowed Pine Avenue
  3. Maximum cross slope 1.5%
  4. Select milling may be required to tie new asphalt overlay into existing curb/gutter

## SECTION A - A

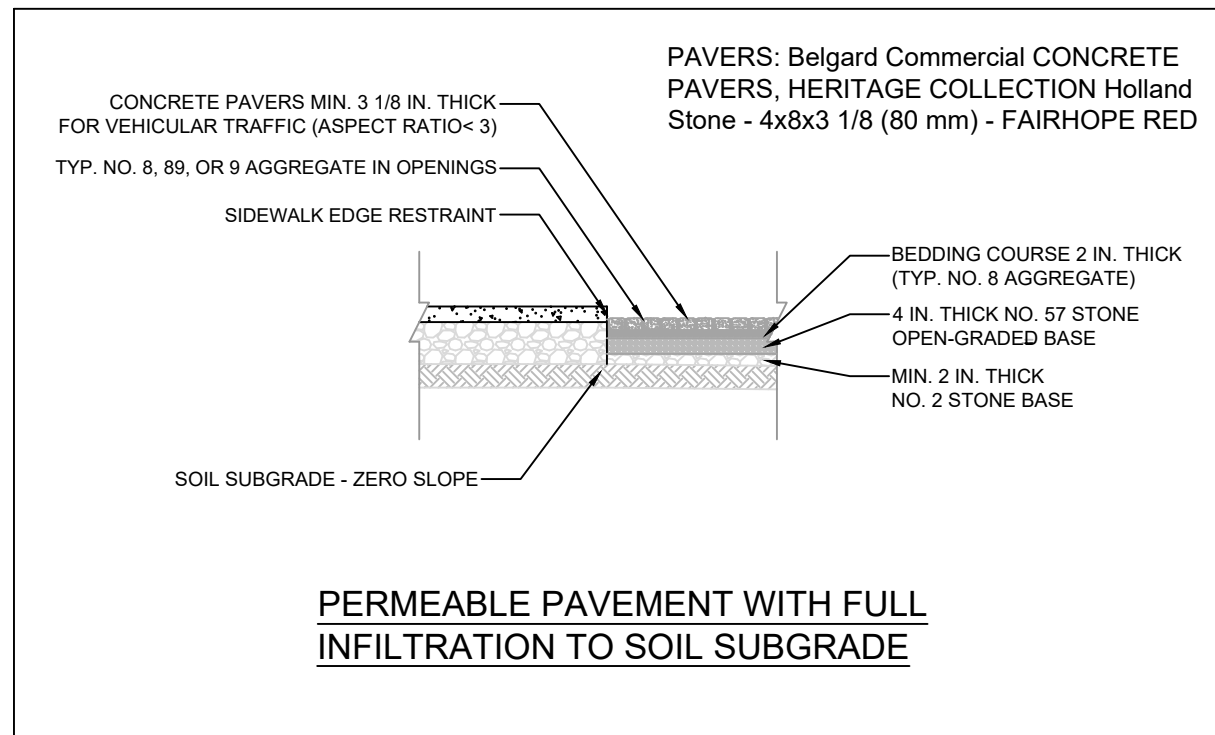
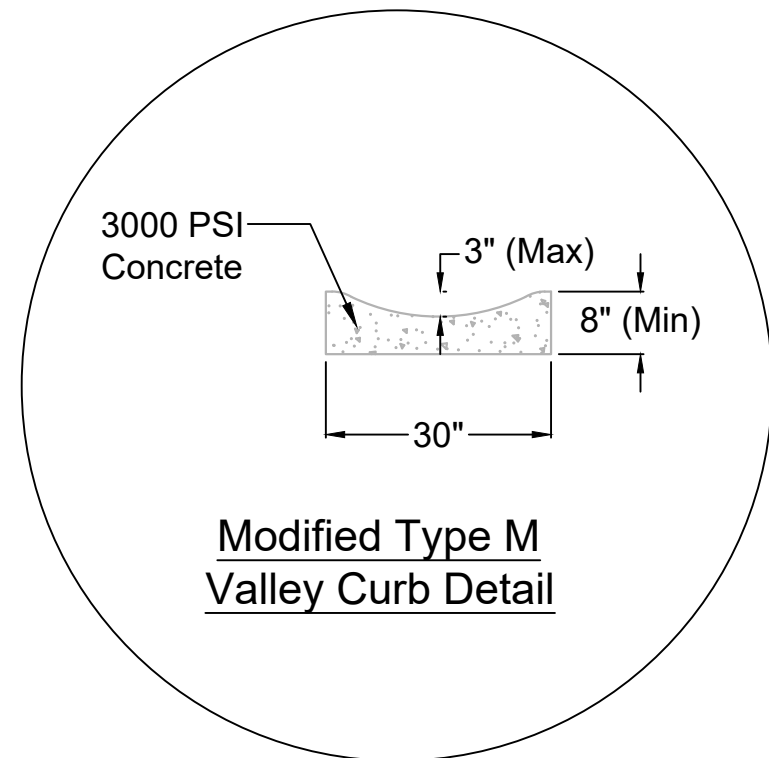

<b>PINE AVENUE - ONE-WAY CONVERSION</b>		
City of Fairhope, Public Works		
Date: July 31, 2023	Drawn By: R.D. Johnson, PE	Cross Section & Details
Scale: N.T.S.	2024-PWI 001	Page 8 of 10

Junction/Inlet/Conflict Box Notes:

1. Junction Box may be cast in place concrete or build in place with 8" CMU.
2. Cast in place may formed with 6" wall thickness.
3. Both shall use #4 rebar at 8" O.C. with all CMU cells grouted
4. The existing boxes at the both ends of the respective pipe runs shall serve as the established invert elevation (US & DS) of the pipe run - Contractor shall establish necessary controls to maintain invert elevations.
5. Bottoms and tops shall be concrete 6" in thickness, with #4 rebar 8" O.C. both ways and tops shall have standard manhole UNO.
6. 12 L.F. of Curbing to form the throat on the S-1 Inlets shall be considered a subsidiary obligation of the unit price of the S-1 Inlet

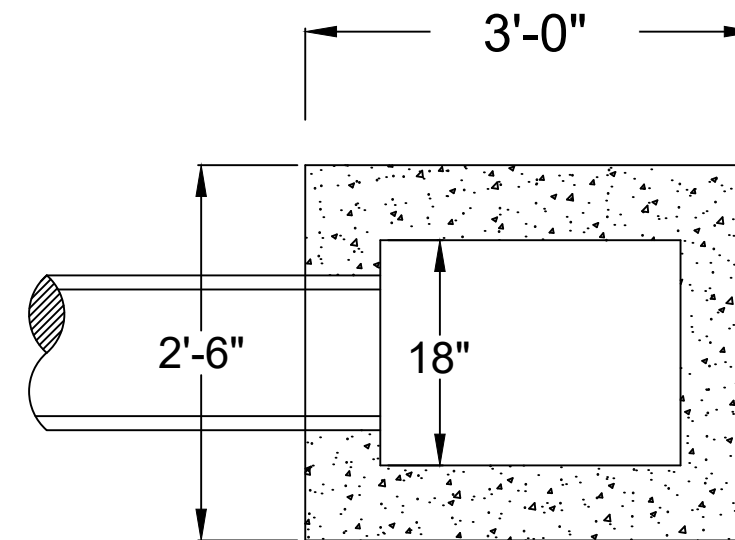
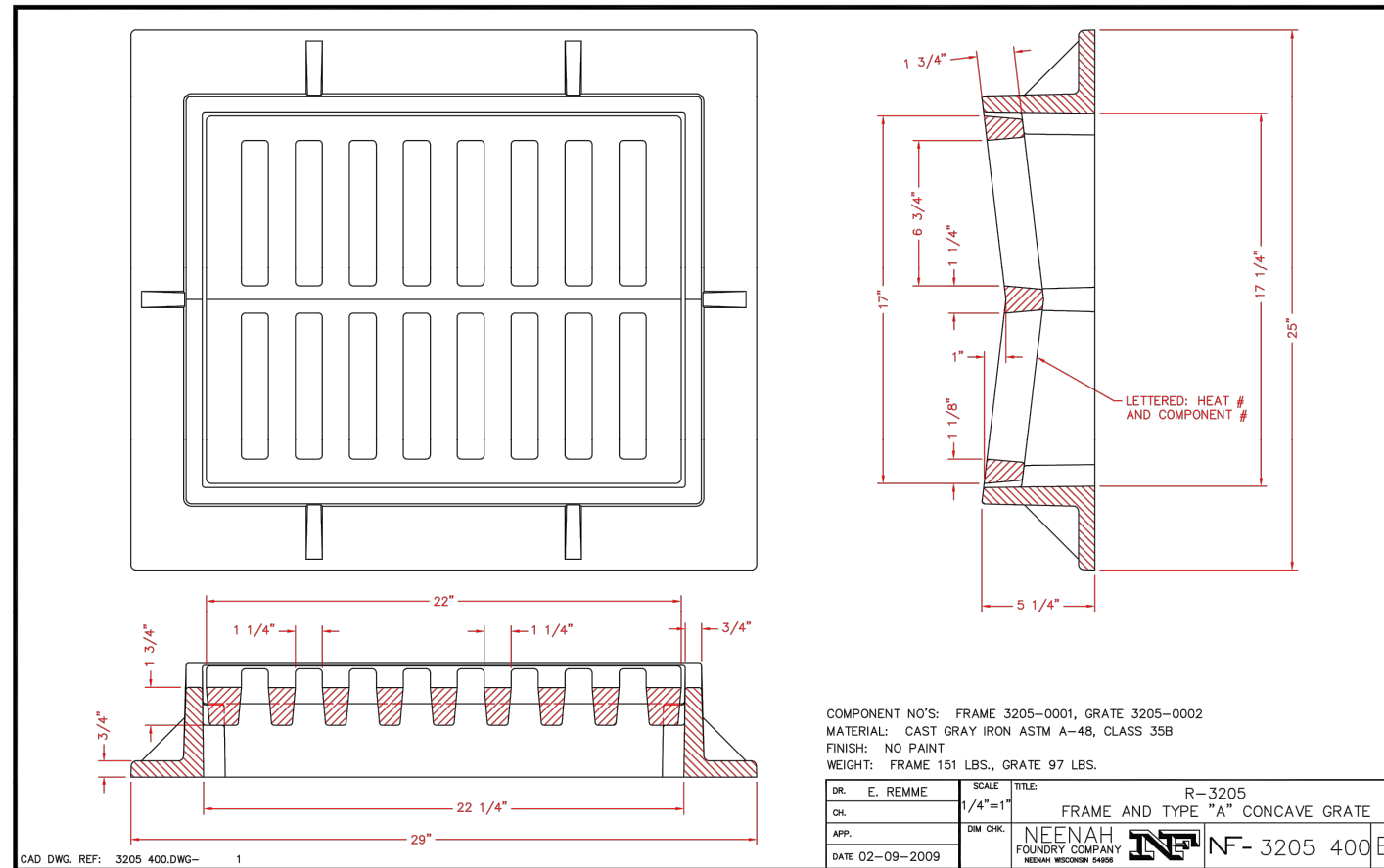

JUNCTION BOX DETAIL

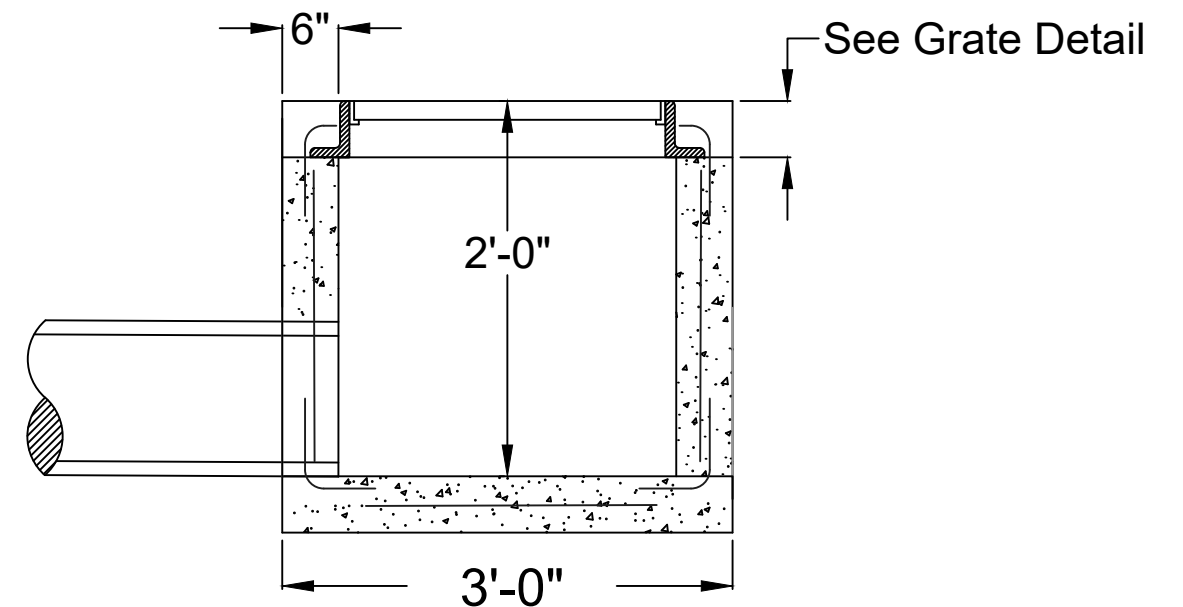

PINE AVENUE - ONE-WAY CONVERSION

City of Fairhope, Public Works

Date: July 31, 2023	Drawn By: R.D. Johnson, PE	Drainage Details
Scale: N.T.S.	2024-PWI 001	Page 9 of 10

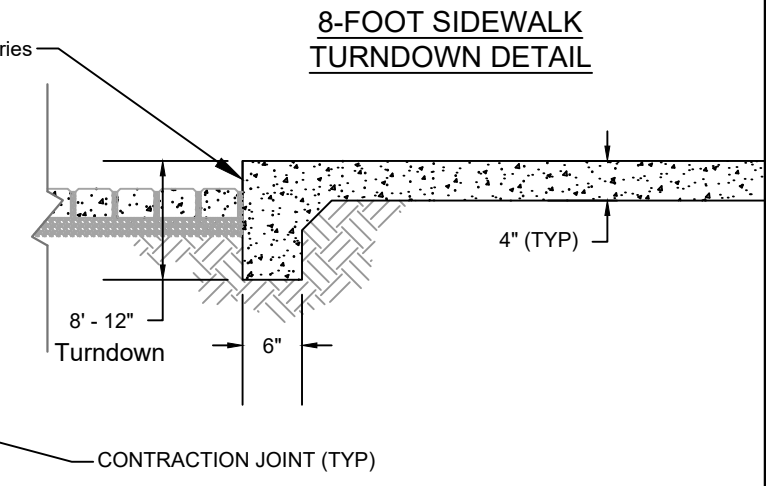
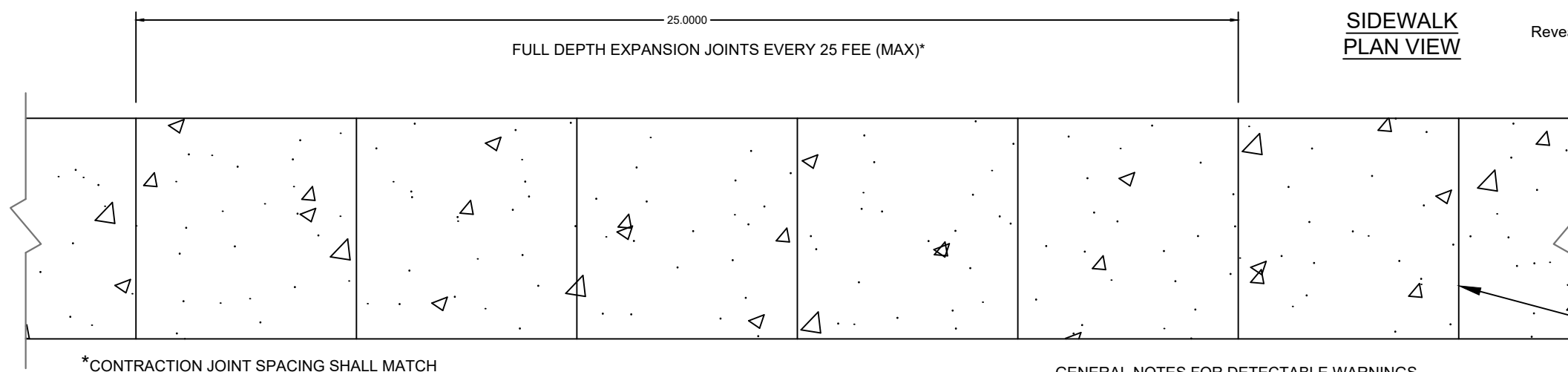

\*CONTRACTION JOINT SPACING SHALL MATCH SIDEWALK WIDTH, EXPANSION JOINTS SHALL BE SPACED TO MATCH CONTRACTION JOINT SPACING

**GENERAL NOTES FOR DETECTABLE WARNINGS**

1. CURB RAMPS MUST CONTAIN A DETECTABLE WARNING SURFACE THAT CONSISTS OF RAISED TRUNCATED DOMES COMPLYING WITH 2010 ADA STANDARDS FOR ACCESSIBLE DESIGN.
2. THE SURFACE MUST CONTRAST VISUALLY WITH ADJOINING SURFACES INCLUDING SIDE FLARES - COLOR TO BE BRICK RED.
3. DETECTABLE WARNING SURFACES MUST BE SLIP RESISTANT AND NOT ALLOW WATER TO ACCUMULATE.
4. ALIGN TRUNCATED DOMES IN THE DIRECTION OF PEDESTRIAN TRAVEL WHEN ENTERING THE STREET.
5. DETECTABLE WARNING SURFACES SHALL BE A MINIMUM OF 24" IN DEPTH IN THE DIRECTION OF PEDESTRIAN TRAVEL.
6. DETECTABLE WARNING SURFACES SHALL BE A MINIMUM OF 48" IN WIDTH FOR 5'-0" SIDEWALK.
7. DETECTABLE WARNING SURFACES SHALL BE CAST-IN-PLACE - NO ADHESIVE OR FASTENERS.
8. DETECTABLE WARNING SURFACES SHALL BE LOCATED SO THAT THE EDGE NEAREST THE CURB LINE IS A MINIMUM OF 6" AND A MAXIMUM OF 10' FROM THE EXTENSION OF THE FACE OF CURB.

**SIDEWALK DETAIL NOTES:**

1. ALL SIDEWALKS SHALL HAVE A MAXIMUM 2.0% CROSS SLOPE.
2. ALL SIDEWALKS SHALL RECEIVE A BROOM FINISH.
3. ALL SIDEWALK EDGES SHALL HAVE 1/2" RADIUS EDGE.
4. SIDEWALKS SHALL BE CONSTRUCTED WITH FIBER REINFORCED CONCRETE THAT HAS A MINIMUM TWENTY EIGHT (28) DAY COMPRESSIVE STRENGTH OF THREE THOUSAND POUNDS PER SQUARE INCH (3000 PSI).
5. EXPANSION JOINTS SHALL BE A MINIMUM OF 1/2" AND EXTEND THE FULL DEPTH OF THE CONCRETE. EXPANSION JOINT MATERIAL SHALL MEET AASHTO M213 FOR AN ASPHALTIC FIBER EXPANSION JOINT MATERIAL. OTHER ALLOWABLE EXPANSION JOINT MATERIAL IS 1"x4" PRESSURE TREATED PINE WITH NAILS DRIVEN THROUGH EACH SIDE TO PREVENT THE BOARD FROM BEING PUSHED OUT OF JOINT.
6. CONTRACTION JOINTS SHALL BE PLACED AT 5 FOOT INTERVALS\*.
7. WHEN PLACING SIDEWALK AGAINST AN EXISTING CONC. STRUCTURE WHERE IT IS DESIRABLE THAT THE SIDEWALK REMAIN FLUSH, THE SIDEWALK SHALL BE DOWELED INTO THE STRUCTURE.
8. ALL SIDEWALK BASE SHALL BE PLACED ON FIRM, STABLE SUBGRADE. BASE SHALL BE 2"-4" OF COMPACTED COURSE SAND.
9. CONTACT PUBLIC WORKS 24 HOURS PRIOR TO ANY PLACEMENT OF CONCRETE FOR AN INSPECTION.
10. SIDEWALK ALIGNMENT AND CLEAR SPACE WIDTH MAY BE MODIFIED AS EXISTING FIELD CONDITIONS DICTATE - ALL SUBJECT TO THE APPROVAL OF THE DIRECTOR OF PUBLIC WORKS.

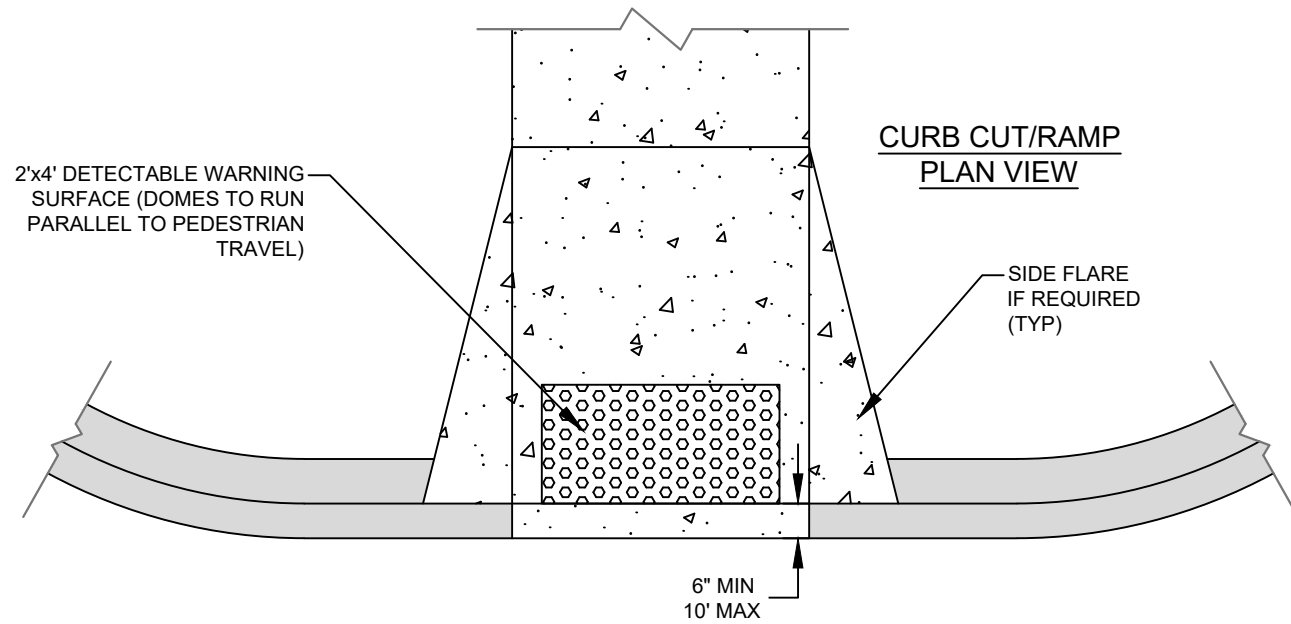
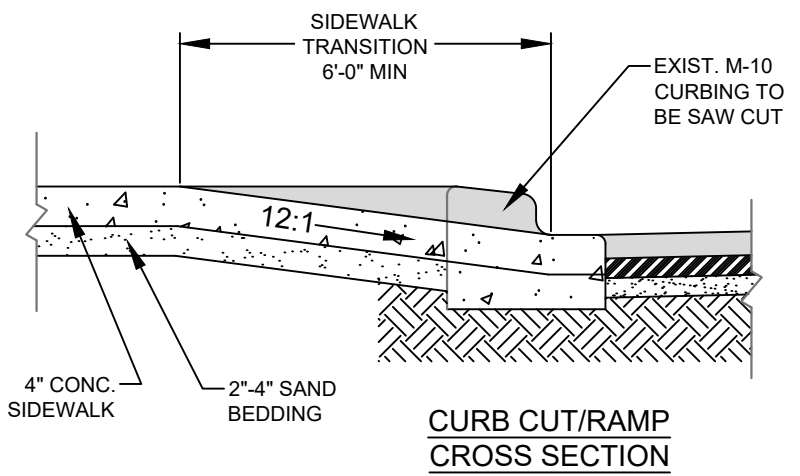
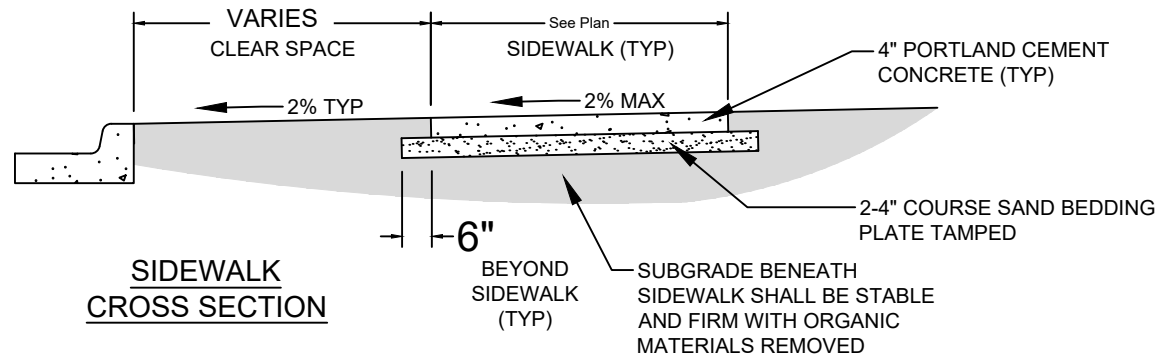

**SIDEWALK DETAIL SHEET**  
SCALE: N.T.S.

**SIDEWALKS - TYPICAL DETAILS**

PROJECT #	DRAW BY: RICHARD D. JOHNSON, PE	
2024-PWI 001		
SCALE	DATE:	12/28/2023
N.T.S.	SHEET	10 OF 10