

INVITATION TO BID ADDENDUM

Addendum No.: 2

Date of Addendum: September 20, 2023

BID No. 23-037

Revised Date, Time: September 20, 2023, 10:00 AM

Due Date, Time: October 05, 2023, 10:00 AM

Title: **Bid No. 23-037 Fairhope Cast Iron Replacement Phase 1**

SCOPE OF ADDENDUM

This addendum details additions to the INVITATION TO BID based on an error in the original solicitation. Revisions to pre-existing language in INVITATION TO BID, Bid No. 23-037, are indicated either by ~~strike through~~ for deletions and underlining for insertions.

Revision 1 CHANGE

Page 4

1.06 SITE EXAMINATION

~~There will be a **MANDATORY** pre-bid meeting on Tuesday, September 12, 2023, at 10:00 A.M. at the Delchamps Room, City of Fairhope Civic Center, located at 161 North Section Street, Fairhope, AL. This mandatory pre-bid meeting will serve as an opportunity for potential bidders to engage project stakeholders, review plans and ask questions.~~

There will be a MANDATORY pre-bid meeting on Tuesday, September 12, 2023, at 10:00 AM CST, at the City Services and Public Utilities Building located at 555 South Section Street, Fairhope, AL. This mandatory pre-bid meeting will serve as an opportunity for potential bidders to engage project stakeholders, review plans and ask questions.

Questions Submitted in Writing:

1. Do we need to be pre-qualified with the City of Fairhope prior to bidding on the cast iron replacement project (Bid No. 23-037)?
 - A. No, pre-qualification is not required. Required qualifications that are requested in the specifications need to be included in your submitted bid package.

Questions from Mandatory Pre-Bid Meeting, September 12, 2023:

1. Asphalt Patching Requirements
 - A. T-patch – mill sides and patch. Use 2lbs./sq. ft. of Sakrete in aggregate. See attached detail drawings.
2. Concrete Rings
 - A. The City will supply concrete rings around valve box lids. The Contractor will supply all concrete and asphalt required for street, sidewalk, curb replacement, or repair.
3. New Meters
 - A. The City will install new meters and change the customers to new services. Contractor is to install the riser, the shutoff valve, and purge the service.
4. Abandonment of Old Mains
 - A. The old mains will be abandoned in place and will not require grouting (assuming the diameter is smaller than 6”).
 - B. The Contractor is not required to purge the abandoned lines.
5. Removal of Risers
 - A. The old risers will need to be removed.
 - B. The method of removal is at the discretion of the Contractor. The risers can be pulled out of the ground or cut at least one (1) foot below grade.
6. Required Camera Work
 - A. Pre-construction and post-construction sewer camera inspection is required.
7. Additional Sewer Cleaning (See Line Item 11 of the Proposal Schedule A)
 - A. Sewer line locating and cleaning is included in the video inspection pricing and is based on the linear feet of gas main and service installations (Proposal Schedule A Line Items 6 through 9). Cleaning in Line Items 6 through 9 will be to the extent required by the City of Fairhope to accept the video inspection. Proposal Schedule Line Item 11 is hourly pricing of sewer cleaning due to additional footage of gas main or service installations. Line Items 12 and 13 are for hourly pricing for any video inspection to cover additional footage for gas main or service installations.
8. New Services and Tie-Over of Old Services
 - A. Phase 1 is approximately 50/50 old services vs. new services.
9. Lead Times for Stopper Fittings and Other Fittings
 - A. Fairhope will verify delivery times for all materials.
10. Timeframe to Begin Construction
 - A. The City expects the recommendation of award to go before the City Council for approval on October 23, 2023. After approval and completion of the resolution, the contract should be sent to the awarded contractor within a week.
11. Edge of Pavement Services
 - A. It is preferable to cut and cap the services at the main. The goal is to retire as much of the old system as possible.
12. City of Fairhope Construction Procedure Changes
 - A. A current copy of all City requirements will be made available to the bidding contractors.
13. Operator Qualification (OQ) Verification Firm
 - A. An OQ may be used if the firm is DOT OQ certified.
 - B. Refer to the scope of work.
14. Notice to Proceed
 - A. The **contract** will go out the same week after the Council approval. The Notice to Proceed will be distributed after the contract is fully executed and a project start date is agreed upon.

Additional Bid Information

- Phase 1 is broken into two different locations to accommodate the City's Street paving plans. Phase 1 needs to start at the Sea Cliff location.
- All questions and/or concerns to bid documents will be addressed in Addendums.
- Please address any additional questions to the City of Fairhope email listed in the Bid Documents.

This addendum shall become part of the INVITATION TO BID and **MAY** be returned with the SEALED BIDS.

RESPONDER

NAME:

SIGNATURE:

TITLE:

DATE:

RIGHT-OF-WAY REPAIR

CORE REPAIR

CORE IS TO BE REPAIRED TO FULL DEPTH OF CONCRETE OR ASPHALT WITH HIGH STRENGTH NON-SHRINK GROUT.

EXISTING PAVEMENT DEPTH

POTHOLE NOT TO EXCEED 12" IN DIAMETER

POTHOLE TO BE BACKFILLED WITH FLOWABLE FILL MEETING CLSM STANDARD (50 PSI BREAK) SEE FLOWABLE FILL MIX DESIGN BELOW

UNDISTURBED SOIL

EXISTING UTILITY TO REMAIN UNDISTURBED AND BEDDED. INSPECTOR MUST VERIFY TOP OF UTILITY BEFORE BACKFILL.

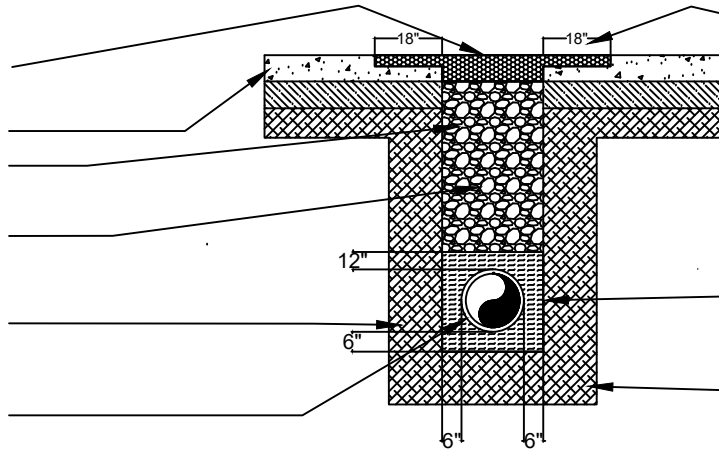

STREET CUT REPAIR

ASPHALT PATCH TO BE MINIMUM 2.5" DEPTH AND MILLED TO 1" DEPTH AND 18" WIDTH ON ALL SIDES OF PATCH TO MATCH EXISTING THICKNESS WITH HOT MIX ASPHALT (424A WEAR SURFACE). INNER SURFACE TO BE TACKED.

EXISTING SUBGRADE MUST BE REPLACED WITH ALDOT 825 TYPE B BASE OR EQUIVALENT. SCARIFY 2LB SQ-FT OF PORTLAND CEMENT INTO SUB GRADE PRIOR TO ASPHALT PLACEMENT.

UTILITY TO BE BEDDED 6" BELOW, 6" BOTH SIDES AND 12" ABOVE.

UNDISTURBED SOIL

NOTES:

1. ALL UTILITIES THAT ARE POTHOLED MUST BE VISUALLY INSPECTED BY INSPECTOR PRIOR TO PLACING ASPHALT.
2. ALL POTHOLES AND STREET CUTS SHALL BE REPAIRED IN ACCORDANCE WITH THE ABOVE DETAIL UNLESS OTHERWISE SPECIFIED BY THE INSPECTOR.
3. ALL POTHOLES AND STREET CUTS MUST BE FLOW FILLED OR FLASH FILLED IF REQUIRED BY INSPECTOR.
4. PRIOR TO PLACEMENT OF ASPHALT/CONCRETE, PAVEMENT EDGE SHALL BE SAW CUT TO A CLEAN, VERTICAL AND STRAIGHT EDGE.
5. ALL EDGES OF A STREET CUT PATCH MUST BE MILLED A MINIMUM OF 18' ON ALL SIDES TO A 1" DEPTH TO CREATE T-PATCH.
6. POTHOLE REPAIRS IN ASPHALT MUST BE REPAIRED PER INSPECTORS DISCRETION.
7. POTHOLE DIAMETER SHALL NOT EXCEED MORE THAN 12".
8. IN UNIMPROVED AREAS, ALL DISTURBED AREAS SHALL BE REGRADED, SEEDED AND MULCHED. ALL SLOPES MUST BE COVERED WITH EROSION BLANKETS OR AS DESIGNATED BY DESC REQUIREMENTS.
9. IF SIDEWALK IS DAMAGED OR POTHOLES THE ENTIRE STONE(S) MUST BE REMOVED AND REPLACED PER THE INSPECTORS DISCRETION.
10. BEDDING MATERIAL DEPTH WHEN INSTALLING UTILITIES MUST BE PER DETAIL OR PER INSPECTORS DISCRETION.
11. ASPHALT STREET CUT REPAIRS MUST BE COMPACTED TO INSPECTORS APPROVAL PER STANDARD DENSITY EXPECTATIONS.
12. MEET WITH INSPECTOR ON ANY ALTERNATIVE REPAIRS OR SPECIAL PROVISIONS.

FLOWABLE FILL MIX DESIGN (ON SITE)	
QUIKRETE ALL PURPOSE WASHED GRAVEL (OR EQUIVALENT)	50 LBS.
QUIKRETE WASHED PLAY SAND (OR EQUIVALENT)	50 LBS.
QUIKRETE PORTLAND CEMENT POWDER (OR EQUIVALENT)	3-5 LBS.
WATER	1.5 GALLONS

Sheet Revisions	
Date	Comments
09/13/2023	John Thomas



City Of Fairhope
555 South Section Street
Fairhope, Alabama 36526

RIGHT-OF-WAY REPAIR

DETAIL PLAN NO.

PW-02

Sheet 1



CITY OF FAIRHOPE, ALABAMA
MANDATORY PRE-BID MEETING

Meeting Date: 09/12/23 at 10:00 a.m.

Bid No. 23-037 Citywide Cast Iron Gas Pipe Replacement – Phase 1

Representative's Name	Company	Phone	Email
Erin Wolfe <i>EW</i>	City of Fairhope – Purchasing Dept.	251-279-6231	Erin.Wolfe@FairhopeAL.gov
Rhonda Cunningham <i>RC</i>	City of Fairhope – Purchasing Dept.	251-990-0118	Rhonda.Cunningham@FairhopeAL.gov
Wes Boyett <i>WB</i>	COF – Gas Superintendent	251-928-8003	Wes.Boyett@FairhopeAL.gov
Steve Stewart	Waverly Const.	251-583-8730	SStewart@waverlycorp.com
Dylan Nettles	Equix	850-666-0141	DNettles@equixinc.com
Don White	Equix	850-878-1212	DWhite@equixinc.com
Michle Lambert	CPS	251-533-5239	Michle-Lambert@cpspipe.com
David Thomas	COF Row Inspector	251-278-7278	david.thomas@fairhopeAL.gov
Tyrel Northrop	Gas Dept	251-928-8003	Ty.Northrop@fairhopeAL.gov
Jennifer Namie	Magnolia River	250-612-2455	jennifer.mcwhorter@magnolia-river.com
George Ladd	COF	(251) 928-8003	george.ladd@FairhopeAL.gov
John Thomas	COF	251-504-1838	John.thomas@FairhopeAL.gov
Paxton DeLamar	GMC Underground	334-319-0283	pdelamar@gmcunderground.com
Jamie DeLamar	GMC Underground	334-319-0284	Jdelamar@gmcunderground.com