

# STANDARD SPECIFICATIONS FOR CONSTRUCTING SANITARY SEWER FACILITIES AND WATER FACILITIES



City of Fairhope, Alabama

Adopted  
December 2, 2002

Amended June 07, 2004  
Amended May 02, 2005  
Amended Dec 01, 2020  
Amended Oct 27, 2021  
Updated June 10, 2022

CITY OF FAIRHOPE  
SPANDARD SPECIFICATIONS FOR WATER DISTRIBUTION AND SEWER COLLECTION SYSTEMS  
TABLE OF CONTENTS

**DIVISION I- SUBMITTAL REQUIREMENTS** **Page No.**

Application for Approval to construct Sanitary Sewer and/or Water Distribution ..... I-1 to I-4

**DIVISION II-DESIGN CRITERIA**

- A. Purpose ..... I-1 to II-4
- B. Sanitary Sewer System Design Criteria .....II-4 to II-6
- C. Water System Design Criteria.....II-6 to II-7

**DIVISION III – CONSTRUCTION SPECIFICATIONS**

**SECTION 1- GENERAL SPECIFICATIONS FOR SANITARY SEWER MAINS**

1.01	SCOPE .....	1-1
1.02	WORK INCLUDED .....	1-1
1.03	SCHEDULE OF OPERATIONS.....	1-1
1.04	PVC PIPE .....	1-1
1.05	DUCTILE IRON PIPE .....	1-3
1.06	ENCASEMENT PIPE .....	1-3
1.07	HIGH DENSITY POLYETHYLENE (HDPE).....	1-4
1.08	PRECAST CONCRETE MANHOLES .....	1-5
1.09	MANHOLE TESTING .....	1-7
1.10	MANHOLE STEPS .....	1-11
1.11	CAST IRON FRAMES AND COVERS.....	1-11
1.12	CONNECTIONS AT MANHOLES.....	1-11
1.13	BRICK MANHOLES .....	1-12
1.14	CONCRETE .....	1-12
1.15	MORTER FOR SEWER STRUCTURES.....	1-12
1.16	RUNNING BOARDS, SADDLE PILES AND MATS .....	1-12
1.17	GRAVEL, SLAG OR CRUSHED STONE .....	1-12

**SECTION 1 GENERAL SPECIFICATIONS FOR SANITARY SEWER MAINS- (CONTINUED)**

1.18 PLUMBING AND BYPASSING..... 1-12

1.19 TRANSITIONS FOR DISSIMILAR PIPES ..... 1-13

1.20 INSPECTION ..... 1-13

1.21 HANDLING PIPE AND ACCESSORIES..... 1-13

1.22 ALIGNMENT AND GRADE ..... 1.14

1.23 EXCAVATION AND PREPARATION OF TRENCH ..... 1.15

1.24 PIPE LAYING..... 1-16

1.25 EMBEDMENT OF PVC GRAVITY SEWER PIPE ..... 1-19

1.26 EMBEDMENT OF POLYETHYLENE SEWER PIPE ..... 1-20

1.27 BACKFILL..... 1-20

1.28 INSTALLATION OF FORCE MAINS..... 1-20

1.29 AIR AND VACUUM VALVES FOR FORCEMAIN..... 1-21

1.30 INSTALLATION OF FORCEMAIN VALVES ..... 1-21

1.31 INFILTRATION ..... 1-22

1.32 AIR TESTING OF SANITARY SEWERS ..... 1-22

1.33 REMOVING AND REPLACING PAVEMENT..... 1-24

1.34 EROSION AND PROPERTY CONSTROL..... 1-25

1.35 CLEAN-UP..... 1-29

1.36 USE OF CHEMICALS ..... 1-29

1.37 PERMITS, CERTIFICATES, LAWS AND ORDINANCES..... 1-29

1.38 UNDERGROUND UTILITIES..... 1-29

1.39 SHOP DRAWINGS AND RECORD DRAWINGS..... 1-30

1.40 ABANDONED SEWER MAINS AND APPURTENANCES ..... 1-30

1.41 PRECONSTRUCTION PHOTOGRAPHS..... 1-30

**SECTION 2- GENERAL SPECIFICATIONS FOR SEWAGE PUMPING STATIONS**

2.01 SCOPE ..... 2-1

2.02 MATERIALS ..... 2-1

2.03 INTENT OF PLANS AND SPECIFICATIONS ..... 2-1

**SECTION 2- GENERAL SPECIFICATIONS FOR SEWAGE PUMPING STATIONS (CONTINUED)**

2.04 SUBMITTALS AND TESTS ..... 2-1

2.05 SITE WORK..... 2-3

2.06 EXCAVATION FOR PIPES AND STRUCTURES ..... 2-4

2.07 CONCRETE ..... 2-4

2.08 WET WELL..... 2-4

2.09 CONTINUITY OF OPERATIONS ..... 2-5

2.10 ELECTRIC POWER METERING ..... 2-5

2.11 ELECTRICAL SERVICE..... 2-5

2.12 DEFINITION OF ACCEPTANCE ..... 2-5

2.13 CLEAN-UP ..... 2-5

2.14 SELF-PRIMING PUMPS..... 2-6

2.15 SELF-PRIMING PUMPS (PIPING AND VALVES)..... 2-14

2.16 SELF-PRIMING PUMPS- (ELECTRICAL)..... 2-15

2.17 SUBMERSIBLE PUMPS ..... 2-23

2.18 SUBMERSIBLE PUMPS (PIPING AND VALVES)..... 2-26

2.19 SUBMESIBLE PUMPS (ELECTRICAL) ..... 2-26

2.20 SUBMERSIBLE PUMPS (CONTROLS)..... 2-31

2.21 SUBMERSIBLE PUMP SPECIFICATION SHEET ..... 2-33

2.22 EMERGENCY GENERATOR..... 2-35

**SECTION 3- REHABILITATION OF SANITARY SEWER MAINS BY THE CURED IN PLACE PIPE METHOD**

3.01 SCOPE..... 3-1

3.02 REFERENCES ..... 3-2

3.03 QUALIFICATIONS ..... 3-2

3.03 SUBMITTALS ..... 3-2

3.05 MATERIALS ..... 3-3

3.06 CONSTRUCTION PROCEDURES ..... 3-4

3.07 COSTRUCTION METHODS..... 3-6

3.08 POST TELEVISIONING OF COMPLETED SECTIONS..... 3-9

3.09	WARRANTY.....	3-9
------	---------------	-----

**SECTION 4- URETHANE/EPOXY REHABILITATION IN MANHOLES**

4.01	SCOPE.....	4-1
4.02	LINING OF MANHOLES.....	4-1
4.03	LINING OF MANHOLES USING CURED IN PLACE EPOXY RESIN LINER.....	4-3
4.04	REPLACEMENT OF MANHOLE FRAME AND COVER.....	4-5
4.05	SALVAGING MANHOLE FRAME AND COVER.....	4-5
4.06	RAISING OF EXISTING MANHOLE FRAME AND COVER.....	4-5
4.07	INFLOW DISH.....	4-6
4.08	CHIMNEY SEAL.....	4-6
4.09	MANHOLES LACKING BENCHES AND INVERTS.....	4-6
4.10	WARRANTY.....	4-6

**SECTION 5- GENERAL SPECIFICATIONS FOR WATER MAINS**

5.01	SCOPE.....	5-1
5.02	WORK INCLUDED.....	5-1
5.03	SCHEDULE OF OPERATIONS.....	5-1
5.04	MATERIALS.....	5-1
5.05	INSPECTION.....	5-11
5.06	HANDLING PIPE AND ACCESSORIES.....	5-11
5.07	REMOVING AND REPLACING PAVEMENT.....	5-12
5.08	ALIGNMENT AND GRADE.....	5-13
5.09	EXCAVATION AND PREPERATION OF TRENCH.....	5-14
5.10	PIPE LAYING.....	5-15
5.11	JOINTING PIPE.....	5-16
5.12	SETTING VALVES, VALVE BOXES FITTINGS AND BLOW OFFS.....	5-16
5.13	SETTING HYDRANTS.....	5-17
5.14	PLUGGING DEAD ENDS.....	5-18
5.15	ANCHORING OF BENDS, TEES AND PLUGS.....	5-18
5.16	HYDROSTATIC TESTING.....	5-18

5.17 CHLORINATION OF COMPLETED PIPELINE ..... 5-20

**SECTION 5- GENERAL SPECIFICATIONS FOR WATER MAINS (CONTINUED)**

5.18 CONCRETE ..... 5-22

5.19 EROSION AND PROPERTY CONTROL ..... 5-22

5.20 BACKFILLING ..... 5-26

5.21 MAINTENANCE OF SURFACES ..... 5-26

5.22 CLEAN-UP ..... 5-27

5.23 USE OF CHEMICALS ..... 5-27

5.24 PERMITS, CERTIFICATES, LAWS AND ORDINANCES..... 5-27

5.25 UNDERGROUND UTILITIES..... 5-27

5.26 SHOP DRAWINGS AND RECORD DRAWINGS..... 5-27

5.27 ABANDONED WATER MAINS AND APPURTENANCES ..... 5-28

5.28 PRECONSTRUCTION PHOTOGRAPHS..... 5-28

5.29 PRESSURE TEST AND CLORINATION ADJACENT TO EXISTING WATER LINES..... 5-28

5.30 EXISTING WATER SYSTEM ..... 5-29

5.31 DUST CONTORL ..... 5-29

5.32 PUBLIC SAFETY ..... 5-29

5.33 EXTRA DEPTH FOR WATER LINES ..... 5-29

5.34 TAPPING OF WATER MAINS ..... 5-29

## **STANDARD DRAWINGS LIST**

- S-1 PRECAST MANHOLE DETAILS PIPE DIAMETER LESS THAN 24-INCH
- S-2 PRECAST MANHOLE DETAIL PIPE DIAMETER GREATER THAN 24-INCH
- S-3 PRECAST MANHOLE DETAILS STANDARD MANHOLE FRAME AND COVER
- S-4 PRECAST MANHOLE DETAILS STANDARD MANHOLE DROP CONNECTIONS
- S-5 PRECAST MANHOLE DETAIL BOOD AND MANHOLE JOINT DETAILS
- S-6 TYPICAL SANITARY SEWER LATERAL CONNECTION
- S-7 SERVICE CONNECTION TO CIPLINED SANITARY SEWER MAINS
- S-8 TYPICAL SANITARY SEWER POINT REPAIR
- LS-1 LIFT STATION DETAILS
- LS-2 LIFT STATION DETAILS
- LS-3 LIFT STATION DETAILS
- LS-4 LIFT STATION DETAILS
- LS-5 LIFT STATION DETAILS
- W-1 TYPICAL  $\frac{3}{4}$ " WATER SERVICE METER DETAIL

**CITY OF FAIRHOPE**

**APPLICATION FOR APPROVAL TO CONSTRUCT SANITARY SEWER AND/ OR WATER DISTRIBUTION FACILITIES IN THE CITY OF FAIRHOPE PLANNING JURISDICTION**

**I. GENERAL INFORMATION**

Applications for approval to construct wastewater facilities and/or water distribution facilities within the City of Fairhope planning jurisdiction shall be completed and submitted by the applicant to the City of Fairhope Sewer Superintendent for approval. Approved applications will be required for Fairhope Planning Commission approval of facilities or developments within the Fairhope Planning Jurisdiction. Review and approval of this application is a pre-requisite to submission of a preliminary plat application to the City of Fairhope Planning Commission, as appropriate.

Applications shall include the following general information items in addition to completion of Items II through VIII and conformance with the attached Division II - Design Criteria Provisions:

1. Project name and description of area served
2. Total area served, (Acres)
3. Estimated start of construction date
4. Estimated construction completion date
5. A map showing the design service area of the proposed sanitary sewer system

**II. APPLICANT**

I, the undersigned, am fully aware that the statements made in this application for approval of wastewater and/or water facilities are true, correct and complete to the best of my knowledge.

\_\_\_\_\_  
Mailing Address

\_\_\_\_\_  
Signature of Applicant

\_\_\_\_\_  
Telephone No.

\_\_\_\_\_  
Name and Title

\_\_\_\_\_  
Date

\_\_\_\_\_  
Representing Owner/Company

**III. ENGINEER**

This is to certify that this application has been prepared under my direction and the plans and specifications for these wastewater and/or water facilities have been designed by me and are in conformance with sound engineering practices and the City of Fairhope requirements.

\_\_\_\_\_  
Mailing Address

\_\_\_\_\_  
Signature of Engineer

\_\_\_\_\_  
Company Name

\_\_\_\_\_  
Name and Title

\_\_\_\_\_  
Telephone Number

\_\_\_\_\_  
Alabama Registration Number

\_\_\_\_\_  
Date



**IV. CRITICAL ELEVATIONS FOR WASTEWATER FACILITIES**

- A. Twenty-five (25) year flood
- B. Top of lowest manhole
- C. Invert of proposed pipe at each existing manhole connection
- D. Invert of existing manhole(s)
- E. Top of lift station structure
- F. Invert of lift station influent line(s)
- G. Pump(s) on
- H. Pump(s) off

**V. QUANTIFICATION OF DESIGN FOR WASTEWATER FACILITIES**

A. FLOW

	NO. OF UNITS	FLOW/UNIT (GPD)	ESTIMATED FLOW (GPD)
1. Single Family Dwelling	@		
2. Condominiums, Apartments	@		
3. Swimming Pools	@		
4. Motels	@		
5. School	@		
6. Commercial	@		
7. Industrial	@		
8. Other	@		

Average Daily Flow \_\_\_\_\_ GPD  
 Minimum Daily Flow \_\_\_\_\_ GPD  
 Peak Hourly Flow \_\_\_\_\_ GPM  
 Peak Daily Flow \_\_\_\_\_ MGD  
 Peaking Factor \_\_\_\_\_

B. GRAVITY SYSTEM

- 1. Pipe material
- 2. Pipe diameter (inches)
- 3. Minimum Slope (percentage)
- 4. Pipe velocity (cfs)
- 5. Minimum depth of cover (feet)

C. FORCE MAIN SYSTEM

1. Force Main

- a. Pipe material
- b. Pipe diameter (inches)
- c. Minimum design flow velocity (fpm) in pipe
- d. Minimum depth of cover (feet)

2. Head Conditions

- a. Static head (feet)
- b. Friction head (feet)
- c. Total dynamic head (feet)

3. Wet-Well

- a. Volume, (cf)
- b. Min. detention time at peak hourly flow (minutes)
- c. Time between pumps on (minutes)
- d. Ventilation present
- e. Strainer basket present

4. Pumps

- a. Pump manufacturer/Model No.
- b. Type of pumps
- c. Number of pumps
- d. Pump capacity  
No. 1 \_\_\_\_\_ GPM @ \_\_\_\_\_ TDH;      \_\_\_\_\_ HP  
No. 2 \_\_\_\_\_ GPM @ \_\_\_\_\_ TDH;      \_\_\_\_\_ HP
- e. Pump controller  
Manufacturer/Model No.
- f. Flow totalizing capability present
- g. Equipment weight  
pump, lbs.  
motor, lbs.

5. Electrical

- a. Electrical panel layout
- b. Voltage
- c. Phase
- d. Automatic restart capability
- e. Alarm manufacturer/Model No.
- f. SCADA system

- 6. Building
  - a. Interior 3/4" hose bibb present
  - b. Minimum unobstructed distance around equipment (feet)
  - c. Loading dock present
  - d. Overhead support beam present
  - e. Ventilator present
  - f. Number of electrical receptacles
    - 120 volt
    - 230 volt
  - g. Freeboard of curb (inches)
  - h. Area of building (sf)

**VI. CRITICAL ELEVATIONS FOR WATER FACILITIES**

- A. Minimum elevation of three feet above the 100-year flood plain for all above ground structures
- B. Pumps (on)
- C. Pumps (off)

**VII. QUANTIFICATION OF DESIGN FOR WATER FACILITIES**

- A. FLOW

The pumps shall have a rated capacity of \_\_\_\_\_ GPM when operating against a TDH of \_\_\_\_\_. The pumps shall also deliver not less than 150% of rated capacity at a pressure not less than 65% of rated pressure. Minimum suction pressure is \_\_\_\_\_ PSIG. Motor and pump speed shall not exceed \_\_\_\_\_ RPM. Pump pressure shut-off head shall not exceed 140% of rated pressure.

**VIII. REQUIRED SUBMITTALS ATTACHED WITH THIS APPLICATION**

- A. Drawings and Specifications
- B. Site plan detailing area to be served
- C. Calculations
- D. Pump curves
- E. Building construction plans
- F. O/M manuals
- G. Permanent Easement Descriptions
  - 1. Sanitary Sewer Mains or Water Mains (Minimum 20 ft. width). If both sanitary sewer mains and water mains are installed, a minimum 30 feet width shall be required.
  - 2. Pumping Stations for either wastewater or water (Minimum 30 ft. x 30 ft.)
- H. Flood verification certificates for facilities constructed within the 100 year flood plain

**STANDARD SPECIFICATIONS FOR CONSTRUCTING  
SANITARY SEWERFACILITIES**

**DIVISION II - DESIGN CRITERIA**

**A. PURPOSE**

The purpose of these guidelines is to establish technical and design specifications for the City of Fairhope and other entities proposing sanitary sewer facilities and/or water distribution facilities within the **Planning Jurisdiction** of the City of Fairhope. The required criteria have been established to assist with ensuring quality construction for all sanitary sewer and water distribution facilities within the City of Fairhope planning jurisdiction and uniformity for facilities accepted for maintenance by the City of Fairhope. Any deviation from the criteria contained herein shall be evaluated by the Fairhope Water and Sewer Superintendent for approval based on compliance with approved operation and maintenance requirements. **The City of Fairhope Water and Sewer Superintendent reserves the right to recommend denial of any building permit(s) and/or recommend denial to the Planning Commission any development found to be non-compliant with these specifications.** Plans and specifications shall be prepared and certified by a professional engineer registered in the State of Alabama.

To assure maintainability and minimize inventory costs, certain equipment manufacturers are included on the City of Fairhope approved equipment and materials list. Lift stations and booster pump station equipment, as well as all appurtenant materials for the construction of new sewer and water distribution facilities shall be new and unused.

If requested by the entity constructing the sewer and/or water distribution facilities, the City of Fairhope will take ownership and maintain sanitary sewer and/or water distribution facilities provided the following conditions are satisfied:

1. Preliminary acceptance of the facilities is granted by the City of Fairhope after construction is completed and upon approval of a resolution of dedication by the Fairhope City Council and full execution of the current form of the *City of Fairhope Maintenance and Guaranty Agreement*. A maintenance bond, in the amount required by the Fairhope Subdivision Regulations shall accompany the Maintenance and Guaranty Agreement. Preliminary acceptance will be evaluated on compliance with the guidelines and standards set forth in this document. The plans shall be further defined as a record drawing set of plans detailing actual construction items including references for laterals, valves, and other appurtenances. As-built plans shall be submitted in digital format and included with the application for final plat approval and/or certificate of occupancy, as appropriate. Format shall be in accordance with the City of Fairhope's current standard. The current digital format is AutoCad (DWG) submitted on a CD. Utilities, roads, subdivision layout, text, and miscellaneous items shall be grouped on individual layers/levels on the digital drawings. Coordinate system shall be NAD 1983 Alabama West Zone State Plane in US survey monuments and lot corners in text format. Text documentation that lists all files being submitted and describes the data in each file including a schedule of layers or levels in the drawing(s) shall also be provided.

The City of Fairhope has prepared a detailed GIS Sewer Map for the entire sewer system of Fairhope. It includes pipes, manholes and lift stations with locations, sizes and inverts of all. It also includes inspection information for manholes and other and the sewer system has been modeled for run capacities. In an effort to keep this map current, the City must be able to update it as new development takes place in Fairhope and has established guidelines for engineers in preparing construction plans. The engineer shall coordinate with the City as the GIS map is an asset to all

users. Listed below are the guidelines for submitting final construction plans related to GIS mapping.

**As-Built Plans**

- Submit Schedules for Manholes, Gravity Pipe, Pump Stations, Force Mains, Water Mains, and Wet Wells.
- Submit ESRI Shapefiles for Manholes, Gravity Pipe, Pump Stations, Force Mains, Water Mains, laterals, valves, Wet Wells, and all other appurtenances. Shapefiles may be included within a geodatabase.
- Shapefiles shall be NAD 1983 State Plane Alabama West FIPS 0102 Feet. The Pipe Numbers in these shapefiles shall be the same as those shown in the schedules described above.
- Sewer structures that the proposed development will tie into shall be obtained from the City and shall reflect the naming convention for the sewer extension required by the City. The subdivision engineer will be responsible for obtaining design data for existing City Sewer structures including but not limited to rim and invert elevations.
- Record drawings shall be submitted in AutoCad formats with a clear description of each level or layer.
- Schedules shall contain the fields in the order shown in the tables below.

**Manholes:**

Manhole No.	Northing	Easting	Rim Elevation	Invert Elevation	Diameter	Depth	Downstream Pump Station	Material
-------------	----------	---------	---------------	------------------	----------	-------	-------------------------	----------

**Gravity Pipe:**

Pipe No.	Start Node	Stop Node	Diameter	Material	Length	Slope
----------	------------	-----------	----------	----------	--------	-------

**Pump Stations:**

PS No.	Northing	Easting	Design Head	Design Flow	Max Head	Max Flow	Shutoff Head	Serial No.	RPM	Impeller Size	Mfg	Model No.
--------	----------	---------	-------------	-------------	----------	----------	--------------	------------	-----	---------------	-----	-----------

**Force Mains:**

Force Main No.	Start Node	Stop Node	Diameter	Material	Length	Velocity	Upstream Invert	Downstream Invert
----------------	------------	-----------	----------	----------	--------	----------	-----------------	-------------------

**Water Mains:**

Main No.	Start Node	Stop Node	Diameter	Material	Length	Velocity	Upstream Invert	Downstream Invert
----------	------------	-----------	----------	----------	--------	----------	-----------------	-------------------

2. Final acceptance of facilities submitted to Fairhope for ownership and maintenance by the City of Fairhope shall be granted after a two-year period provided the system is properly operated and maintained by the entity responsible for constructing the system and the system is determined to continue to meet the City of Fairhope standards after the two-year period. **City of Fairhope Staff shall inspect all improvements prior to the expiration of the Maintenance and Guaranty Agreement. Release of the Maintenance Bond shall not occur until all improvements are deemed acceptable by the Water and Sewer Superintendent.**

3. Sewer facilities constructed, maintained, and operated by entities other than the City of Fairhope shall provide an annual performance bond or letter of credit to the City of Fairhope by December 31 of each year. The bond amount shall be set by the City Council each year based on the City of Fairhope's estimated replacement value of the sanitary sewer and/or water distribution facilities owned and maintained by other for the purpose of ensuring that sewer and/or water service interruptions, sanitary sewer overflows, and the adverse effects from these conditions for any reason are promptly remedied at the cost of the entity and for no cost to the sewer service customers or the City of Fairhope.
4. Owners of sanitary sewer and/or water distribution facilities shall provide to the City of Fairhope prior to accepting customers a contingency plan for preventing sewer and/or water service interruptions. The plan shall include 24 -hour emergency contact numbers of at least three different operation and maintenance personnel that are authorized to respond on behalf of the system owner in the event of a sewer and/or water service interruption and perform corrections.
5. Sanitary sewer system collection lines shall discharge directly into a treatment facility with a current NPDES permit and available capacity as verified in writing from ADEM. Temporary or permanent discharging of sanitary sewer into holding tanks or facilities for intermittent transporting to treatment facilities shall not be allowed within the City of Fairhope planning jurisdiction.
6. Sanitary sewers shall be separated a minimum of 10 feet clear horizontal distance from any existing or proposed water main. Where sanitary sewers are required to cross water mains a minimum of 18 inches vertical distances between the outside of the mains shall be obtained. Sewer mains at water main crossings shall be constructed with ductile iron pipe with joints at least 9' from the crossing centerline. If these conditions cannot be obtained, additional design considerations approved by the City of Fairhope shall be incorporated to protect both lines and prevent cross contamination.
7. An approved air release valve unit shall be installed at all applicable areas along a force main and in accordance with the installed air release valve manufacturer's recommendations.
8. Sanitary sewer collection systems for multi-customers shall be gravity systems in accordance with the standard specification parameters. Low pressure (multiple grinder pumps) systems shall only be acceptable within the Fairhope Planning Jurisdiction where access for proper maintenance to sewer mains is impractical and cost prohibitive. Cost prohibitive shall be defined as a condition where the estimated cost of a gravity sanitary sewer system is more than 500% of the cost of a low-pressure system. The entity constructing the facilities shall provide the Fairhope Sewer Superintendent **actual cost proposals for both systems for review and determination of the accepted alternate by the Fairhope Sewer Superintendent.** Cost proposals shall be representative of the current local costs for materials and installation. Sample cost proposal forms are included herein as an appendix. For new developments, the cost comparison shall itemize all necessary items as appropriate per system, and related erosion control measures and paving items. The exclusion of these items in the cost comparison shall not in any way relieve the entities responsibility from meeting all local standards and regulations relating to these items. **The City of Fairhope Water and Sewer Superintendent reserves the right to recommend denial of any building permit(s) and/or recommend denial to the Planning Commission any development that does not adequately justify installation of low-pressure sanitary sewer systems in lieu of gravity sanitary sewer systems.**

When approved as an acceptable system in lieu of a gravity system, low pressure systems shall be constructed to provide flow conditions that will minimize the development of corrosive and odor conditions from H<sub>2</sub>S and to prevent the development of sewage BOD<sub>5</sub> concentrations greater than 350 mg/l.

9. Force main systems shall include clean out provisions for performing maintenance cleaning of the force main system. The distance between cleanout accesses shall not exceed one mile. Access cleanouts shall allow for inserting and retrieval of approving maintenance “pigs” without excavating or “breaking into” the force main. Access cleanouts configuration and materials shall be approved by the Fairhope Sewer Superintendent.
10. All new sanitary sewer and/or water distribution facilities shall be constructed in accordance with the City of Fairhope standard specifications for sanitary sewer and water distribution facilities, the Alabama Department of Environmental Management (ADEM) standards and design criteria for water and sanitary sewer facilities, Ten States Standards and Environmental Protection Agency (EPA) Capacity Management, Operations and Maintenance (CMOM) provisions. When conflicts between these standards occur, the more stringent of the requirements as determined by the City of Fairhope shall be required. Several of the standards required by the City are in accordance with the Recommended Standards for Water Works “Ten States Standard”.

**B. SANITARY SEWER SYSTEM DESIGN CRITERIA**

<u>DESIGN PARAMETER</u>	<u>DESIGN VALUE</u>
1. MINIMUM VELOCITY (ft/sec) IN GRAVITY LINES	2.0
2. DESIGN ROUGHNESS COEFFICIENT (Manning’s n/Hazen-Williams C)	0.013/130
3. FLOW DEVELOPMENT	
a. Single family dwelling (GPCD)	125
4. MINIMUM PEAK HOURLY FLOW FACTOR	2.5
5. MINIMUM SLOPE (%)	
a. 8" Sanitary Sewer Gravity Main	0.40
b. 10" Sanitary Sewer Gravity Main	0.28
c. 12" Sanitary Sewer Gravity Main	0.22
d. 16" Sanitary Sewer Gravity Main	0.13
e. 18" Sanitary Sewer Gravity Main	0.12
f. 20" Sanitary Sewer Gravity Main	0.09
g. 24" Sanitary Sewer Gravity Main	0.08
h. 30" Sanitary Sewer Gravity Main	0.07
6. MINIMUM DEPTH (inches from top of pipe to ground surface)	36

DESIGN PARAMETER	DESIGN VALUE
7. FORCE MAIN	
a. Pipe material of construction (Ductile Iron, PVC, or HDPE)	
b. Minimum depth of cover (inches)	36
c. Velocity range (FPS)	3.5 - 5.5
8. PUMPS	
a. Maximum pumping rate (GPM)	Peak Hourly Flow
b. Minimum number of pumps per station	2
c. Pump type	Self Priming or Submersible
9. WET-WELL	
a. Maximum detention time between pump run cycles (minutes)	15
b. Maximum detention time at peak flow (hours)	2
c. Minimum diameter (feet)	6
d. Grinder pump station minimum storage capacity (hours)	24
10. SITE	
a. Fence (chain link or wood)	---
b. Roadway (paved, single lane, 12% maximum grade)	---
c. Maximum landscaped slope (%)	20
d. Design flood event	100 years
11. BUILDING	
a. Minimum height (feet)	8
b. Minimum unobstructed floor space (feet)	4
c. Ventilation requirements (air changes/hour):	
(1) Continuous duty	12
(2) Intermittent	30
d. Water service line (inches)	3/4
e. Interior lighting (48", 4 bulb, 40W fixtures/100SF) (each)	2
f. Interior electrical receptacles (each):	
(1) 110 volt	4
(2) 220 volt	2
12. ELECTRICAL	
a. Incoming service:	
(1) Voltage (volts)	460/230
(2) Phase	3
b. Control voltage (volts)	120



#### ADDITIONAL SANITARY SEWER REQUIREMENTS:

1. Gravity sanitary sewer collection mains shall be a minimum of eight (8) inches in diameter.
2. Where velocities will exceed 15 fps, special provisions shall be made to protect against displacement by erosion and impact.
3. Sanitary sewers shall be laid with uniform slope between manholes.
4. Sanitary sewers placed on 20 percent slopes or greater shall be anchored securely with an approved method and spacing.
5. Curvilinear alignment of sanitary sewers shall not be utilized in construction.
6. Manholes shall be installed on average every 400 feet and shall not exceed a distance of 450 feet. Manholes shall also be installed at: a) all changes in grade, size, or alignment; b) all intersections; and c) the end of each line.
7. Manholes shall be a minimum of 48 inches in diameter with minimum access diameter of 22 inches.
8. An approved drop connection shall be installed at each manhole where the sanitary sewer pipe is 24 inches or more above the manhole invert.
9. Sanitary sewage system components and piping configurations shall comply with the City of Fairhope Standard Details for sewer systems.
10. New sewage pumping stations shall be equipped with provisions for “quick connections” and piping configurations to allow for connecting to emergency bypass pumps. Supervisory control and data acquisition (SCADA) systems in accordance with the SCADA systems currently in use by the Fairhope sewer system for monitoring operating conditions of the pump station from the Fairhope Water Reclamation Facility shall be installed at new sewage pumping stations.

#### C. WATER SYSTEM DESIGN CRITERIA

##### 1. Pressure

All water mains, including those not designed to provide fire protection, shall be sized after a hydraulic analysis based on flow demands and pressure requirements. The system shall be designed to maintain a minimum pressure of 20 psi (140 kPa) at ground level at all points in the distribution system under all conditions of flow. The normal working pressure in the distribution system should be approximately 60 to 120 psi (410 – 825 kPa) and not less than 35 psi (240 kPa).

##### 2. Diameter

The minimum size of water main for providing fire protection and serving fire hydrants shall be six-inch diameter. Larger size mains will be required if necessary, to allow the withdrawal of the required fire flow while maintaining the minimum residual pressure of 20 psi.

3. Fire protection

As required by the fire authority having jurisdiction.

4. Small mains for domestic service

The minimum size of water main in the distribution system where fire protection is not to be provided should be a minimum of three (3) inch in diameter. Any departure from minimum requirements shall be justified by hydraulic analysis and future water use and can be considered only in special circumstances.

5. Hydrants

Water mains not designed to carry fire-flows shall not have fire hydrants connected to them.

6. Dead Ends

- a. In order to provide increased reliability of service and reduce head loss, dead ends shall not be permitted except for new construction of a single street with a cul-de-sac. All new subdivisions shall be looped feed to provide adequate fire protection.
- b. Where dead-end mains occur, they shall be provided with a fire hydrant if flow and pressure are sufficient, or with an approved flushing hydrant or blow-off for flushing purposes. Flushing devices should be sized to provide flows which will give a velocity of at least 2.5 feet per second in the water main being flushed. No flushing device shall be directly connected to any sewer.

STANDARD SPECIFICATIONS FOR  
CONSTRUCTING SANITARY SEWER FACILITIES

DIVISION III - CONSTRUCTION SPECIFICATIONS

SECTION 1

GENERAL SPECIFICATIONS FOR SANITARY SEWER MAINS

1.01 SCOPE

These general and detailed specifications form a part of the Contract documents and shall govern the handling and installation of sanitary sewer mains, manholes, service connections, and accessories described herein, and as shown on the accompanying plans. Existing sanitary sewer facilities are owned and operated by the City of Fairhope, hereinafter referred to as "Owner". The construction methods employed in the placement of the sanitary sewer main and appurtenances shall be in accordance with current codes, practices and specifications of the Owner.

1.02 WORK INCLUDED

All labor, equipment, and material necessary to complete the work as stipulated herein. The Contractor shall clear and grub as necessary, remove as much of the pavement as may be necessary; excavate the trenches and pits to the required dimensions; excavate the bell holes, construct and maintain all bridges required for traffic control; sheet, brace and support the adjoining ground or structures where necessary; handle all drainage or ground water; guard the site, unload, haul, distribute, and lay the pipe fittings and accessories; rearrange the branch connections to main sewers, or rearrange other conduits, ducts or pipes where necessary; connect new sewers to existing sewers; connect existing sewer laterals to new mains; replace all damaged drains, sewers, or other structures; backfill the trench and pits; restore the roadway surface; remove surplus excavated material; clean the site of the work; and maintain the street or other surface over the trenches.

1.03 SCHEDULE OF OPERATIONS

The Contractor shall prepare and submit to the Owner/ Engineer for approval by the Owner/ Engineer, prior to beginning construction, a schedule of his proposed operations outlining his sequence of pipe installation, connections to existing sewers and placement of new sewers in service. Contractor shall provide 48 hours' notice prior to making any connections to existing infrastructure.

1.04 PVC PIPE:

A. Gravity Pipe - Plastic pipe for gravity sewers, stacks and laterals, and fittings shall be unplasticized polyvinyl chloride (PVC), meeting or exceeding ASTM Specification D3034 latest edition, Classification SDR 26. Pipe lengths shall not exceed 20 feet and provisions shall be made at each joint to accommodate expansion and contraction. All pipe and fittings shall be joined by means of an integral wall bell and spigot and sealed with a rubber gasket. This joint shall be capable of withstanding an internal hydrostatic pressure of 25 psi for one hour with no leakage.

In every instance where pipe enters or leaves a manhole, a fitting shall be provided which will accommodate expansion and contraction of the pipe, release strain on the

pipe (caused by differential settlement between pipe and manhole) and provide a rubber ring water seal between pipe and manhole. Where indicated fittings shall also be provided for stub outs for future connections and stub out shall be sealed with PVC plug.

PVC pipe shall be installed in accordance with ASTM D2321, latest edition. Deflection of PVC pipe after installation and backfill shall not exceed 5 percent. Pipe found to be deflected more than five percent shall be replaced.

All PVC gravity sewer lines shall be tested for diametric deflection using a GO-NO-GO type mandrel or other approved method. The mandrel shall have an outside diameter of not less than 95 percent of the PVC pipe inside diameter. This testing shall be accomplished prior to final acceptance, but at least 30 days after the pipe has been backfilled completely.

- B. Force Main Pipe - PVC pipe for force mains shall be provided as shown on the plans. PVC pipe shall conform to the requirements of ASTM D2241 for pressure pipe with iron pipe outside diameter or AWWA C900 standard for pressure pipe with ductile iron pipe outside diameter. Pipe shall be a minimum Class 250 for ASTM D2241 or a standard dimension ratio of 18 or heavier for AWWA C900. Unless design conditions dictate otherwise, ASTM D2241 with a minimum Class of 250 shall be installed. PVC pipe for sewer force mains shall be permanently marked with "Sanitary Sewer Force Main" or similar designation. Adequate connections on the list of approved materials for the City of Fairhope shall be provided when transition from minimum class 200 to ductile iron. Pipe joints shall be integral bell and spigot type with rubber ring sealing gasket. The pipe bell shall be designed to be at least as strong as the pipe wall. Standard lengths shall be 20 feet except that 15% of total footage for a particular project may be random lengths of not less than 10 feet each. Each piece of pipe shall be tested by the manufacturer to 600 psi for a minimum of five seconds. The bell shall be tested with the pipe. PVC fittings shall conform to the requirements of the adjoining force main pipe in addition to ASTM D1784, D1599, D3139, and F477.

All sanitary sewer PVC pipe shall be either green or brown in color. Black pipe may be substituted provided a stripe further defined below is applied to the surface of the pipe 180 degrees from the normal pipe markings. The pipe shall be placed in the trench with the stripe visible from the top of the pipe trench. For pipe sizes four inches in diameter and smaller, a one-inch-wide continuous green stripe shall be applied. For pipe diameters greater than four inches, a three-inch wide continuous green solid stripe shall be applied.

- C. Fittings for PVC Pipe – Fittings for PVC pipe shall be made of cast iron or ductile iron conforming to ANSI/AWWA C110/A21.10. Cast iron or ductile iron fittings shall be as specified for ductile iron pipe. Fittings shall be provided with a transition gasket specifically designed to accommodate the outside diameter of the PVC force main. Also certified test results detailing that fitting meet or exceed these Specifications shall be provided.

- D. Marking Tape for PVC Pipe - Metalized marking tape shall be installed with PVC sanitary sewer gravity and force mains to allow for future locating with standard pipe locating equipment and associated pipe protection. Marking tape shall be green, three (3) inches wide, marked "CAUTION: BURIED SEWER LINE BELOW," and installed from 6 to 12 inches above the pipe. Marking tape shall be specifically manufactured for the proposed environment. Backfill shall be carefully placed to a depth of 3 inches over tape by hand to assure that the tape is secured in place over the pipe. Fourteen (14) gage wire shall be installed along the length of the PVC mains at a location one foot above the top of the pipe.

#### 1.05 DUCTILE IRON PIPE

Ductile iron pipe and fittings shall be as hereinafter specified except that the minimum wall thickness shall be as specified in ASTM A746 for thickness Class 52. Extra thickness shall be provided where required by deep cover in accordance with ASTM A746, table 12, for type 2 laying conditions. Pipe shall be centrifugally cast.

Ductile iron pipe for sewers shall be mechanical joint or push on joint conforming to ASTM A746. Ductile iron pipe and fittings shall have a cement mortar lining conforming to ANSI/AWWA C104/A21.4 with Permax coating or equivalent.

The pressure rating, metal thickness, net weight of pipe without lining, length of pipe, name of manufacturer, and letters "D.I." shall be clearly marked on each length of pipe.

Where it is necessary to cut new ductile iron pipe or existing cast iron pipe, in no case shall it be cut by burning, but shall be cut by saw, cutter, abrasion or other approved means.

- A. Ductile Iron Fittings - Ductile Iron or cast-iron fittings shall be designated for pressure rating of 250 psi and shall be in accordance with ANSI/AWWA C110/A21.10 or to AWWA C153. Fittings shall be mechanical joint. Ductile iron compact fittings shall be in accordance with ANSI/AWWA C153/A21.53-88. Fittings shall have cement mortar lining with Permax coating or equivalent, and the exterior shall be coated with an approved bituminous coating.
- B. Polyethylene Sheath – Unless otherwise indicated by soil testing, polyethylene sheath shall be installed on all ductile iron pipe. The exterior of the ductile iron pipe shall be covered with a sealed polyethylene sheath in accordance with AWWA Specifications C105. Polyethylene sheath shall be on the approved list of materials and manufacturers. Backfill shall be as specified elsewhere in these Specifications. Care shall be taken not to damage the polyethylene sheath during the backfill operation. Any damage shall be replaced or repaired.

#### 1.06 ENCASEMENT PIPE

- A. General: Steel encasement pipe shall conform to AASHTO Standards and Alabama Department of Transportation standards when placed under highways and to AREMA 1-5-B where placed under railroads. Except where noted on the plans, encasement pipe shall be installed by a dry boring method in which the casing pipe is placed simultaneously with the boring action.

The Contractor shall inspect the roadway or track directly above the Work before, during, and after the placing of the encasement for settlement. If settlement occurs,

the Contractor shall, at no additional expense to the Owner, bring the roadway surface to its original grade by means approved by the State Highway Department or realign the track to its proper grade by means approved by the railway owner.

- B. Material: Welded Steel Encasement Pipe shall be of the size and wall thickness shown on the plans and shall conform to ASTM Designation A252, Grade 2 and the Alabama Department of Transportation standard specifications. The pipe shall be coated on the outside only with a coal tar primer coat followed by a single application of hot coal-tar enamel 3/32 inches thick  $\pm$  1/32 inches and a bonded 15 pound composition felt wrap or approved equal. At the option of the Contractor, uncoated pipe may be used subject to approval of the State Highway Department or railway company provided the wall thickness is at least 0.063 inch greater than shown on the plans or in the proposal.
- C. Encasement Spacers: Encasement pipe spacers and their accessories shall be used to maintain separation of the encasement pipe and the carrier pipe. The installation and spacing from center to center of encasement spacers shall be in accordance with the manufacturer's requirements. Spacers shall be stainless steel.
- D. Encasement End Seals: Encasement end seals shall be 1/8 inch synthetic rubber, stainless steel zipper or closer, pressure molded to the rubber and a rubber protective strip attached to the seal under the zipper. Seals shall be secured to encasement using 1/2 inch stainless steel "Band-It" clips or thumbscrew banding clips with a polyethylene strip placed under each clip. a telescopic fold shall be placed in the seal before banding to assure proper flexibility between the carrier pipe and the casing.

#### 1.07 HIGH DENSITY POLYETHYLENE (HDPE)

Pipe shall be made from high density polyethylene resin compound which meets ASTM D1248. Pipe shall be on the Owner's list of materials and approved manufacturers. Dimensions and workmanship shall conform to ASTM F714.

The polyethylene pipe shall be the nominal pipe size and dimension ratio shown on the plans, or in the proposal. Installation shall be in accordance with ASTM D2321 or as modified herein.

Shipping lengths of pipe shall be assembled into one continuous length at the job site by thermal butt-fusion. Fusion machine and fusion machine operator shall be approved by pipe manufacturer. The resultant joint shall be as strong as the intervening lengths.

Jointing of pipe and installation of outlets shall be in accordance with the pipe manufacturer's written recommendations. The pipe manufacturer shall provide the services of a trained representative to instruct the Contractor's forces in the proper techniques for jointing of pipe and the installation of outlets or other items.

Contractors shall provide written certification from the manufacturer that the personnel performing the joint welding has received proper training for the welding of the manufacturer's piping material.

Installation of polyethylene pipe in areas where flotation is probable whether on land or a subaqueous location installation shall conform with manufacturer's recommendation.

Polyethylene pipe shall not be crimped in any way during construction.

Fabricated polyethylene bends shall be manufactured by pipe manufacturer. SDR of fabricated polyethylene bends shall be equal to SDR of connecting pipe. When connecting polyethylene pipe to manholes provide a rubber ring water seal between pipe and manhole. Grouting around the ring shall also be required inside and outside the manhole.

Deflection of polyethylene pipe after installation and backfilling shall not exceed 5 percent.

#### 1.08 PRECAST CONCRETE MANHOLES

Precast manholes shall conform to the requirements of ASTM C-478, latest edition with a minimum wall thickness of 5 inches. Every manhole shall meet the following requirements:

- A. All aggregate shall be made from 97 percent calcareous rocks. Manholes shall be smooth and free from fractures and honeycombs.
- B. All Portland Cement shall be Type II or Type V. All concrete shall be a minimum of a 7 bag (658 pound) mix. The minimum allowable tricalcium aluminate content of Portland Cement is 8 percent
- C. The cone shaped top section shall be eccentric and the cone and riser sections shall conform to the requirements of ASTM C-478, latest edition, and as hereinafter specified. The top section of manholes less than 6 feet in depth shall be flat concrete slabs and shall conform to the requirements of ASTM C-478. Basis of acceptance for flat slab tops shall be either proof of design testing or rational design calculations as described in ASTM C-478 and shall be submitted to the Engineer for review.

Both cone shaped top sections and flat slab tops shall be designed to withstand a minimum H-20 wheel loading in accordance with AASHTO requirements.

- D. Manhole bottoms shall be either 8 inches thick cast in place concrete or integral with the lower section of riser walls as hereinafter specified.
  - 1. Poured in place bottoms shall be a minimum of 8" thick and shall be not less than 12 inches in diameter larger than the outside of the riser section. The top of the manhole bottom shall be not less than 3 inches below the lowest pipe invert. The invert of the manhole shall be built up with cement grout. Special care shall be taken to assure a good seal around the manhole bottom. The joint between the bottom and walls shall be sealed on the outside with grout.
  - 2. Bottoms integral with side walls shall be set on a prepared bed of not less than 2 inches of reef shell or an approved equal. The bed shall be accurately shaped to fit the manhole bottom to assure uniform bearing over the entire manhole bottom. The invert of the manhole shall be built up with cement grout.
  - 3. Backfill of undercut shall not be permitted. Any undercut shall be filled with concrete with a minimum compressive strength of 4,000 psi.

4. Anti-Flotation Collars shall be required for all manholes unless otherwise directed by the Engineer. Anti-flotation collars shall be at least 12 inches in diameter larger than the outside sections of the riser.
  
- E. The minimum nominal diameter of manholes shall be 48 inches for pipe sizes less than 24 inches. Where larger manholes are required, eccentric transition sections may be installed not less than 6 feet above the invert, except where total depth of the manhole will not permit.
  
- F. Joints in riser and cone sections shall have rubber gaskets or an approved equal meeting the requirements of ASTM C-443.
  
- G. New manholes shall be supplied with an approved cast-in flexible manhole pipe connector (boots) for each pipe cutout. The flexible manhole pipe connector (boot) shall meet ASTM C-923 requirements. The flexible manhole pipe connector (boot) shall be secured to incoming and outgoing pipes with a stainless-steel clamp. The clamp shall be tightened to 60-inch pounds of torque or as required by the manufacturer. The connector shall be installed in the manhole wall in accordance with the manufacturer's recommendations. Grouting around boots shall be required as recommended by the boot manufacturer.

Existing manholes cored for each pipe cutout shall be fitted with flexible manhole pipe connectors (boots). The flexible manhole pipe connector (boot) shall meet ASTM C-923 requirements. The flexible manhole pipe connector (boot) shall be secured to incoming and outgoing pipes with a stainless-steel clamp and a stainless-steel rigid adjustable expansion ring. The clamp shall be tightened to 60-inch pounds of torque or as required by the manufacturer. The connector shall be installed in the manhole wall in accordance with the manufacturer's recommendations.

Existing pipes requiring a doghouse manhole or a cast in place manhole shall be supplied with a water stop gasket connector. The connector shall be secured to the pipe with a stainless-steel clamp. The clamp shall be tightened to 60-inch pounds of torque or as required by the manufacturer. The connector shall be cast in or sealed with non-shrink grout or an approved equal. The connector shall be installed in accordance with the manufacturer's recommendations.

Connection manholes for HDPE pipe shall be in accordance with the City of Fairhope current standards.

All connectors shall be sized specifically for the pipe material, pipe size, and manhole size being used.

- H. Every manhole shall be fully and completely built as the work progresses and as each is reached.
  
- I. Manholes shall be neatly and accurately built, according to the plans and specifications, of proper materials and in a workmanlike manner.
  
- J. The invert and bottom curves of all manholes shall be neatly and accurately constructed and so formed as to facilitate the entrance and flow of sewage over them.



- K. Manhole riser sections and cone shall have manufacturer installed steps conforming to the section entitled "Manhole Steps."
- L. The Contractor shall furnish and properly set in mortar to line and grade all cast iron covers and frames. Brick stacks not more than 12 inches and not less than 6 inches in total height shall be used to adjust manhole covers and frames to the proper grade where tops of manholes are to be flush with existing or proposed ground or streets or where directed. Brick stacks will not be required where tops of manholes are to be above the existing or proposed ground surface. Concrete adjusting ring shall have a tolerance of approximately 3/16 inch from the center of the manhole opening.
- M. When required, stub outs of required size shall be built into manholes to receive either present or future branch lines. Where it is not intended to construct the branch lines at once, the stub outs thus inserted must be securely closed in such a manner that future connections can be made without breaking the stub out.
- N. Where manholes intercept existing sewer mains or laterals connected to existing manholes, the Contractor shall keep the sewer main or lateral service to the existing manhole intact until the next adjacent section of new sewer is completed and approved. The laterals or mains shall then be broken and fed to the new sewer laterals or mains and the dead end of the abandoned mains or laterals plugged with an approved plug.
- O. A black mastic joint sealer, included on the list of materials and approved manufacturers, or an approved equal shall be placed on top of the cone section of the manhole before setting the castings to prevent infiltration.
- P. Castings shall conform to the section entitled "Cast Iron Frames and Covers."
- Q. Pipes entering a manhole more than 24 inches above the manhole invert shall be a drop connection.
- R. Manholes shall be provided with an inflow dish. The inflow dish type shall be approved by the City of Fairhope. Inflow dishes shall be installed in the manhole to prevent excessive rainwater from entering the manhole covers. The inflow dish and components shall be manufactured of materials resistant to corrosion from atmospheres containing hydrogen sulfide and dilute sulfuric acid. The inflow dish shall allow venting of sewer gases. The inflow dish shall be stainless steel unless otherwise specified by the Engineer and shall be anchored to the manhole by a tether. Installation shall be in accordance with manufacturer recommendations and shall not impede the proper seating of the manhole cover.
- S. Manholes shall be provided with a chimney seal. The chimney seal type shall be approved by the City of Fairhope. The chimney seal shall be installed in new or existing manholes to stop infiltration in the chimney area. The chimney seal shall be flexible and allow repeated vertical and horizontal movement due to traffic loading. The chimney seal shall be secured to the manhole cone. The chimney seal shall have a design life of at least 25 years. The chimney seal shall be installed in the manhole in accordance with the manufacturer's recommendation.

- T. Before installation of any precast manholes, the following information shall be submitted and approved the Engineer:
1. Project name and number.
  2. Manhole manufacturer.
  3. Manhole shop drawings including dimensions, materials, and manhole designation numbers.
  4. Gasket manufacturer and specifications.
  5. The name of the independent testing laboratory proposed to certify the manholes.
  6. Written acknowledgement that material certification in accordance with these standard specifications.
- U. Failure to comply with any part of these Specifications shall be reason for rejection of the entire manhole. Any defects shall be remedied by the Contractor immediately. Any manhole section which does not meet these Specifications shall be removed from the job site. Refusal to comply with any part of these Specifications shall be reason for denial or revocation of permission to install precast manholes.
- V. All new and rehabilitated manholes and manhole components shall be warranted to be free from defects in materials and workmanship for a period of five (5) years from the date of project acceptance. Should a defect occur during this five (5) year period that is attributable to the installation or materials, then this defect shall be repaired within four (4) weeks from the date of defect notification to the Contractor at no additional cost to the Owner.
- W. Manholes with connections to force mains shall be properly lined with corrosive prevention products approved by the City of Fairhope.

#### 1.09 MANHOLE TESTING

A. Laboratory Testing:

1. Testing of manhole sections shall be performed in accordance with ASTM C-478, latest edition. Testing shall be performed by an Engineer approved independent testing laboratory. The services of a testing laboratory shall be acquired by the manhole supplier to test and stencil each manhole section. The cost of the testing shall be borne by the manhole supplier. The stencil shall be a certification by the testing laboratory that the manhole section was constructed in compliance with the Owner's standard specifications for precast manholes. The stencil shall be a minimum of 8.5 in. x 11 in. in size with letters no smaller than:" high and painted with permanent paint. The stencil shall be located on the interior of each manhole section. The top of the stencil shall be no more than 6 inches below the top of each precast section. The color of the stencil lettering shall be safety orange. The stencil shall be legible and include the following:

(TESTING LABORATORY NAME) -  
(IDENTIFICATION NO. OF INSPECTOR)  
CERTIFIES THIS MANHOLE SECTION  
COMPLIES WITH CITY OF FAIRHOPE  
STANDARD SPECIFICATION INSPECTED (MONTH/YEAR)

2. Manholes shall be inspected and certified by the manhole supplier's testing laboratory at the supplier's warehouse. Only in emergency situations shall the manholes be inspected and certified by the manhole supplier's testing laboratory in the field. Manholes shall not be installed by the contractor unless the certification is stenciled on the interior of each manhole section. Manholes shall not be certified after installation. Manholes physically damaged during shipment will not be accepted.
3. The manhole supplier shall rotate the testing laboratories it uses for the inspections discussed herein. No single testing laboratory shall be used for more than six months per year for inspecting manholes.
4. The manhole supplier shall obtain a letter of certification from the aggregate supplier that 97% calcareous aggregate is being provided for the production of manholes. The aggregate supplier shall furnish this letter at least quarterly to the manhole supplier. The manhole supplier shall furnish a letter certifying that this same calcareous aggregate is being used in the production of the manholes being furnished.
5. The manhole supplier shall obtain a letter of certification from the cement supplier indicating that Type II or Type V cement is being provided for the production of manholes. The cement supplier shall furnish this Type II or Type V cement certification letter at least quarterly to the manhole supplier.
6. The manhole supplier shall furnish to the Engineer a document at the completion of each project that states the following:
  - a. The project name.
  - b. A Summary of the manholes provided that includes the diameter, number, and location of each manhole.
  - c. The name of the independent testing laboratory(ies) that certified the manholes.
  - d. The most recent documentation from the aggregate supplier showing that 97% calcareous aggregate was supplied for the manufacture of these manholes.
  - e. Certification from the manhole supplier that the aggregate in item (d) is the same used in producing the manholes.
  - f. The most recent documentation from the cement supplier showing that Type II or Type V cement was supplied for the manufacture of these manholes.
  - g. Certification that all concrete cylinder breaks made during the manufacture of the supplied manholes successfully passed established compressive strength requirements.

Documentation (a) through (g) above, shall also be provided to developers

and other organizations building sanitary sewer systems with the intention of requesting acceptance of said systems by the Owner. This documentation shall be provided to developers or other sewer constructors so that they may submit the documentation to the Engineer for verification.

The manhole supplier shall provide documentation (a) through (g) to the Owner on a quarterly basis. This documentation shall be for all manholes furnished directly to the Owner during the 3-month period preceding the report.

The Owner will not accept projects for which the above documentation cannot be furnished by the sewer constructor's representative. It shall be the responsibility of the sewer constructor's representative to obtain said documentation from the manhole supplier and furnish it to the Owner prior to the acceptance of the facilities by the Owner.

The manhole supplier shall maintain the above documentation for a minimum period of three years from the date of the documentation transmittal.

**B. Vacuum Testing:**

1. All new and rehabilitated manholes shall be tested by the Contractor using the vacuum test method, by following the manufacturer's recommendations for proper and safe procedures. Vacuum testing of manholes and structures shall be performed after curing of linings. Any leakage in the manhole or structure, before, during, or after the test shall be repaired by the contractor for no additional compensation from the Owner.
2. All pipes for vacuum testing entering the manhole shall be installed at the top access point of the manhole. A vacuum of 10 inches of mercury (Hg) (5.0 psi) shall be drawn on the manhole, and the time shall be measured for the vacuum to drop to 9 inches of mercury (Hg) (4.5 psi). Manholes will be considered to have failed the vacuum test if the time to drop 1 inch of mercury is less than the limits shown in the following table:

**Vacuum Test Timetable**

**Manhole Diameter - Inches**

<u>Depth - feet</u>	<u>48 inches</u>	<u>60 inches</u>	<u>72 inches</u>	<u>96 inches</u>
4	10 sec.	13 sec.	16 sec.	19 sec.
8	20 sec.	26 sec.	32 sec.	38 sec.
12	30 sec.	39 sec.	48 sec.	57 sec.
16	40 sec.	52 sec.	64 sec.	76 sec.
20	50 sec.	65 sec.	80 sec.	95 sec.
+ Each 2'	+5 sec.	+6.5 sec.	+8.0 sec.	+9.5 sec.

3. Manhole depths shall be rounded to the nearest foot. Intermediate values shall be interpolated. For depths above 20 feet, add the values listed in the last line of the table for every 2 feet of additional depth.
4. If the manhole or structure fails the vacuum test, the Contractor shall perform additional repairs and repeat the test procedures until satisfactory results are obtained.
5. After the manhole installation and/or rehabilitation work has been completed, the manhole shall be visually inspected by the Contractor in the presence of the Engineer and the Work shall be accepted if found satisfactory to the Engineer. The finished surface shall be free of blisters, "runs" or "sags" or other indications of uneven lining thickness. NO EVIDENCE OF VISIBLE LEAKS SHALL BE ALLOWED.
6. The Contractor shall furnish to the Owner documentation showing the results of the vacuum test for each manhole.
7. All new and rehabilitated manholes may be retested 11 months after the manholes were installed or rehabilitated and must pass the above vacuum test requirements.

#### 1.10 MANHOLE STEPS

Manhole steps shall be steel rods encased in polypropylene plastic and shall be of the type manufactured by M.A. Industries, Inc., or approved equal. Steps shall be Type PS-1 or PS-2, for precast manholes and Type PS-1-B or PS-2-BG for brick manholes. Steps shall conform to the requirements of ASTM C-478. Manhole steps shall be driven into wet well wall during manufacture.

#### 1.11 CAST IRON FRAMES AND COVERS

Cast iron frames and covers shall conform to the plans in all essentials of design. All castings shall be made of clean, even grain, tough gray cast iron. The quality of iron in the castings shall conform to the current ASTM Specification A-48 for Class 30 Gray Iron Castings. Frames shall weigh not less than 260 pounds. Covers shall not weigh less than 120 pounds. The castings shall be smooth, true to pattern and free from projections, sand holes or defects. The portion of the frame and cover which forms the cover seat shall be machined so that no rocking of the cover is possible. The castings shall be coated with coal tar pitch varnish.

On paved streets, the frame and cover shall be set flush with the finished grade and in the plane of the paved surface. In other locations, they shall be set to the grades determined in the field by the Engineer.

#### 1.12 CONNECTIONS AT MANHOLES

Where indicated on the plans or where directed by the Engineer in the field, connections shall be neatly and accurately constructed of proper materials in a workmanlike manner, including the reconstruction of the manhole wall. Connections shall be made at the manhole bottom invert, where possible, and shall in no case be more than two (2) feet

above the manhole bottom invert without a drop connection.

Where indicated on the plans or instructed in the field, drop connections shall be neatly and accurately constructed of proper materials and in a workmanlike manner, in strict accordance with the details shown on the plans. Piping for drop connections shall be ductile iron except where noted otherwise on the drawings.

#### 1.13 BRICK MANHOLES

Brick manholes shall not be permitted.

#### 1.14 CONCRETE

The minimum compressive strength required at 28 days is 3,000 pounds per square inch satisfying pertinent paragraphs of ALDOT Standard Specifications. Field specimens and laboratory tests shall be made in accordance with the standards of the American Society of Testing Materials. The minimum amount of water shall be used to produce a workable mix and shall not exceed six U.S. gallons per sack of cement. Slump shall range between two and five inches.

#### 1.15 MORTAR FOR SEWER STRUCTURES

Mortar for masonry in sewer structures shall be a 1:3 Portland Cement sand mix, provided that hydrated lime or mortar mix may be substituted for, not to exceed 10% by weight of the cement.

#### 1.16 RUNNING BOARDS, SADDLE PILES AND MATS

Running boards, saddle piles and mats shall be two-inch pipe which has been pressure treated with pentachlorophenol, C.Z.C. or other suitable preservative to resist decay.

#### 1.17 GRAVEL, SLAG OR CRUSHED STONE

Gravel, slag, or crushed stone shall be screened, washed and shall be 100% retained by a 1/4" screen. 100% shall pass a 1½" opening and shall be uniformly graded from maximum size to minimum size. Foreign matter shall not exceed 3% by weight when dry.

#### 1.18 PUMPING AND BYPASSING

No sewage or solids shall be dumped, bypassed, or allowed to overflow into streets, streams, ditches, catch basins or storm drains nor will it be allowed to "back up" upstream to such an extent that homes, businesses, etc. along the sewer are flooded.

When pumping/bypassing is required, the Contractor shall supply the necessary pumps, conduits, and other equipment to divert the flow of sewage around the manhole or pumping station at which work is to be performed. The bypass system shall be of sufficient capacity to handle existing flows plus additional flow that may occur during periods of a rainstorm. The Contractor will be responsible for furnishing the necessary labor and supervision to set up and operate the pumping and bypassing system. If pumping is required on a 24-hour basis, all engines shall be equipped in a manner to keep the pump noise at a minimum.

Where pump discharge lines cross streets or alleys, they shall be covered with wooden, or metal ramps designed and installed in such manner that they do not unreasonably impair vehicular traffic traveling said streets and alleys. All "pumping" or "bypassing" work, the arrangement or layout of the pumping and bypassing facilities, and the manholes and sewer lines to be utilized in such work must be approved by the Owner's representative prior to the time said "pumping" and "bypassing" work is started.

Whenever possible, the Contractor and the Owner's representative shall discuss and resolve the use of an arrangement of any "pumping" and "bypassing" facilities well in advance of the time of the need for such work and facilities is anticipated.

The Contractor shall inspect the various sewer lines to determine for himself the quantity and depth of sewage flow in said lines and shall determine therefrom the size of and the number of pumps and related pumping facilities will need to adequately perform the "pumping" and "bypassing" work. No direct payment will be made for pumping and bypassing.

#### 1.19 TRANSITIONS FOR DISSIMILAR PIPES

Transitions for dissimilar pipes up to 12-inch O.D. shall be made by use of a flexible coupling with an adapter busing and stainless-steel band and clamps. Transitions from dissimilar type pipe over 12-inch O.D. shall be made by use of approved adapters specifically designed for this purpose. Joining of dissimilar pipes with concrete collars shall not be permitted except at such places where specifically approved.

#### 1.20 INSPECTION

A. Material at Factory: All materials are subject to inspection and approval at the plant of the manufacturer.

All material shall meet the requirements specified and suppliers of pipe and fittings shall furnish, in triplicate, to the Engineer, an affidavit stating that all pipe and fittings furnished under this contract conform to the requirements as set forth in these specifications.

B. Field Inspection: All pipe and accessories shall be laid, jointed, and backfilled in the presence of the Engineer. The Engineer in charge of construction shall be notified by the Contractor at least twenty-four (24) hours in advance before any section of sewer is checked with the "GO-NO-GO" mandrel. The Engineer shall give a certified certificate to the Owner that the pipe after inspection meets the Owner's specifications.

C. Disposition of Defective Material: All material found during the progress of the work to have flaws, or other defects will be rejected, and the Contractor shall promptly remove from the site of the work such defective material.

#### 1.21 HANDLING PIPE AND ACCESSORIES

A. Care: Pipe, fittings, valves, and other accessories shall, unless otherwise directed, be unloaded at the point of delivery, hauled to and distributed at the site of the project by the Contractor; items shall at all times be handled with care to avoid damage. In loading and unloading, items shall be lifted by hoists or slid, or rolled on

sideways in such manner as to avoid shock. Under no circumstances shall they be dropped. Pipe handled on sideways must not be skidded or rolled against pipe already on the ground.

- B. At Site of Work: In distributing the material at the site of the work, each piece shall be unloaded opposite or near the place where it is to be laid in the trench. Pipe shall be retained in shipping cradles when stored along the right-of-way until pipe is ready to be laid. In no case will removal of pipe from cradles be permitted more than 24 hours in advance of placing in trench.
- C. Care of Pipe Coating: Pipe shall be handled in such manner that a minimum amount of damage to the coating will result. Damaged coating shall be repaired in accordance with the pipe manufacturer's recommendations.
- D. Bell Ends (Direction): Pipe shall be placed on the site of the work parallel with the trench alignment and with bell ends facing the direction in which the work will proceed.
- E. Pipe Kept Clean: The interior of all pipes, fittings, and other accessories shall be always kept free from dirt and foreign matter. Each pipe shall have a swab run through it until all foreign matter has been removed.

#### 1.22 ALIGNMENT AND GRADE

- A. General: All pipe shall be laid and maintained to the required lines and grades; with fittings at the required locations for connecting existing service laterals; and with joints centered and spigots home.
- B. Protecting Underground and Surface Structures: Temporary support, adequate protection, and maintenance of all pipelines, underground and surface utility structures, drains, sewers, and other obstructions encountered in the progress of the work shall be furnished by the Contractor at his own expense. Existing side drainpipes and curbs and gutters that interfere with the Contractor's operation shall be removed and replaced in kind at no additional cost to the Owner.
- C. Sub-Surface Explorations: Existing underground pipes and structures have been shown on the plans from existing records for the contractor's convenience. The contractor shall verify locations of existing underground pipes and structures through examination of all available records and shall make all explorations and excavations necessary to determine the location of existing pipelines, service connections, or other underground structures. This investigation shall be made in advance of any pipe laying and any damage to existing pipelines, service connections or underground structures shall be repaired by the Contractor at no additional cost to the Owner.
- D. Establishing Grade: The Contractor may use laser beam for establishing grade of sewer, but he shall be entirely responsible for the accuracy of the Work. If laser beam is used, the Contractor shall check the grade of sewer using a level and rod, at 50 feet to 100 feet from manhole from which pipe is being laid, and at each manhole and anytime a new set up is made in the same section.



In lieu of the laser beam, the Contractor may, at his option, have a minimum of 3 batter boards placed ahead of the pipe always laying not to exceed a maximum distance of 50 feet between batter boards.

The Contractor shall furnish the Engineer with a centerline cut sheet for approval prior to beginning construction on the sewer line. The cut sheet will contain data obtained by the Contractor in the file and will show station number, centerline elevation, manhole offset hub elevation, invert elevation, centerline cut, hub cut, and percent of grade. Data will be obtained and shown at each 50-foot station, manhole stations, and at each point of significant change in terrain elevation.

### 1.23 EXCAVATION AND PREPARATION OF TRENCH

- A. Description: The trench shall be dug to the alignment and depth required and only a minimum distance in advance of pipe laying. The trench shall be so drained that workmen may work therein efficiently.
- B. Width: The trench width may vary with and depend upon the depth of trench and the nature of the excavated material encountered, but in any case, shall be of ample width to permit the pipe to be laid and jointed properly and the backfill to be placed and compacted properly. The minimum width of trench shall be as approved by the Engineer; the maximum clear width of trench shall be not more than two and one-half (2-1/2) feet greater than the pipe diameter at the trench bottom, unless otherwise specified by the latest OSHA requirements.
- C. Pipe Foundation in Good Soil: The trench, unless otherwise specified, shall have a flat bottom conforming to the grade to which the pipe is to be laid. The pipe shall be laid upon sound soil cut true and even so that the barrel of the pipe will have a bearing for its full length.
- D. Correcting Faulty Grade: Any part of the trench excavated below grade shall be corrected with approved material, thoroughly compacted.
- E. Pipe Foundation in Poor Soil: When the bottom uncovered at subgrade is soft and cannot support the pipe, a further depth shall be excavated and refilled to pipe foundation grade as required. Material used for backfilling to the elevation of the pipe will be paid for separately.
- F. Bell Holes Required: Bell holes of ample dimensions shall be dug in earth trenches at each joint to permit the joining to be made properly.
- G. Bracing: When the material through which the trench is excavated tends to fall in, run, or cave, the sides of the trench shall be braced, open sheeted or close sheeted, to an extent necessary to protect the pipe being laid. Such sheeting shall remain in place until the backfill is carried to a point at least two (2) feet above the top of the pipe. The Contractor shall exercise every precaution in removing the sheeting in order to avoid damaging the pipe. Should there be evidence that the removal of sheeting would damage the pipe, the sheeting shall be left in place and no additional compensation will be allowed, therefore. The top of sheeting left in place shall be at least twelve (12) inches below natural ground. The Contractor shall place such other sheeting and/or bracing as he and his surety deem necessary to protect workmen and the public.

- H. Care of Surface Material for Re-Use: If local conditions permit their re-use, all surface materials suitable for re-use in restoring the surface shall be kept separate from the general excavation material.
- I. Manner of Piling Excavated Material: All excavated material shall be piled in a manner that will not endanger the work and that will avoid obstructing sidewalks and driveways. Gutters shall be kept clear, or other satisfactory provisions made for street drainage. Also, storm drains shall be kept clear.
- J. Trenching by Machine or by Hand: The use of trench-digging machinery will be permitted except in places where operation of same will cause damage to trees, building, or existing structures above or below ground, in which case hand methods shall be employed.
- K. Barricades, Guards and Safety Provisions: To protect persons from injury and to avoid property damage, adequate barricades, and construction signs in accordance with Section G of the Alabama Manual on Uniform Traffic Control Devices, shall be placed and maintained during the progress of the construction work and until it is safe for traffic to use the trenched highway. Rules and regulations of the local authorities and OSHA regarding safety provisions shall be observed.
- L. Traffic and Utility Controls: Excavations for pipe laying operations shall be conducted in a manner to cause the least interruption to traffic. Where traffic must cross open trenches, the Contractor shall provide suitable bridges at street intersections and driveways. Hydrants under pressure, valve pit covers, valve boxes, curb stop boxes, fire or police call boxes, or other utility controls shall be left unobstructed and accessible during the construction period.
- M. Flow of Drains and Sewers Maintained: Adequate provisions shall be made for the flow of sewers, drains and water courses encountered during construction, and the structures which may have been disturbed shall be satisfactorily restored upon completion of the work. No separate compensation will be made the Contractor for removal, replacement and restoration of existing facilities.
- N. Property Protection: Trees, fences, poles, and all other property shall be protected unless their removal is authorized; and any property damaged shall be satisfactorily restored by the Contractor. No separate compensation will be made the Contractor for removal of existing obstructions, including abandoned concrete slabs, within the roadway right of way.
- O. Plugging Dead Ends: Dead ends of abandoned or new lines shall be capped or plugged as shown on the plans.

#### 1.24 PIPE LAYING

- A. Manner of Handling Pipe and Accessories into Trench: Proper implements, tools, and facilities shall be provided and used by the Contractor for the safe and convenient prosecution of the work. All pipe, fittings, and accessories shall be carefully lowered into the trench, piece by piece, by means of derrick, ropes or other suitable tools or equipment, in such manner as to prevent damage to pipe or pipe coating. Under no circumstances shall pipe or accessories be dropped into the trench.

- B. Pipe Kept Clean: All foreign matter or dirt shall be removed from the inside of the pipe before it is lowered into its position in the trench and it shall be kept clean by approved means during and after laying.
- C. Batter-Boards for Sewer Lines: The Contractor shall have a minimum of three (3) batter-boards placed ahead of the pipe laying at all times. The Contractor may at his option use a Laser Beam for establishing grade of sewer, but he shall be entirely responsible for the accuracy of the work. If Laser Beam is used, the Contractor shall check the grade of sewer at 50 feet to 100 feet from manhole from which pipe is being laid, and at each manhole, with level or batter-boards.
- D. Laying the Pipe: The pipes and fittings shall be so laid in the trench that after the sewer is completed, the interior surface of the bottom thereof shall conform accurately to grade and alignment. Sewers shall be laid in the direction opposite to the direction of flow with spigot ends of pipe pointing down grade.

While the pipes and fittings are being laid between adjoining manholes in each straight or working section of the sewer, a round circle of light from the finished or other end of the section shall remain constantly in plain view throughout the entire length of such section and shall show the true character and shape of the interior surface of the sewer. The same test shall be applied for each working section after the sewer is completed in all respects and before it is accepted. On completion of sewer lines, the Contractor shall float a wooden ball through each main line. In each case, the size of the ball shall be one inch (1") in diameter less than the sewer through which it is to go.

The Contractor shall pump, bail, or otherwise remove any water which may be found or may accumulate in the trenches and shall perform all work necessary to keep them clear of water while pipe laying is in progress.

Whenever pipe laying is stopped for the night or for any other cause, the end of the pipe shall be securely closed with a stopper to prevent the entrance of water, mud, or other obstructing matter, and shall be secured in such manner as to prevent the end pipe from being dislodged by sliding or other movement of the backfilling.

After placing a length of pipe in the trench, the joint shall be held around the bottom of the spigot, so that it will enter the bell as the pipe is shoved into position.

The spigot shall be centered in the bell, the pipe shoved into position, and brought into true alignment; it shall be secured there with earth carefully tamped under and on each side. Care shall be taken to prevent dirt from entering the joint space, and joints between individual pipes shall be made watertight.

Six-inch (6") diameter tees or wyes shall be inserted in the sewer lines for connection of all existing sewer laterals. The sewer line shall be cut in a neat and workmanlike manner for insertion of tees or wyes. Tees or wyes shall be rolled 45 degrees in the vertical plane or as dictated by existing lateral elevations. All tees or wyes shall be temporarily closed by means of plugs and properly referenced for recovery and connection of existing sewer laterals upon completion of the sewer main construction.

In every instance where pipe enters or leaves a manhole, a fitting shall be provided

which shall accommodate expansion and contraction of the pipe, release strain on the pipe (caused by differential settlement between pipe and manhole) and provide a rubber ring water seal between pipe and manhole. Where indicated, fittings shall also be provided for stub outs for future connections and stub outs shall be sealed with plug fittings. Fittings shall be included in the price of the manholes.

- E. Connecting Existing Sewer Laterals: Wherever existing sewer laterals are intercepted by the excavation for the new sewer, the existing connection shall be maintained temporarily to the old sewer until the particular section of new sewer is completed and tested, then the house lateral shall be cut at the required location and connected to the new sewer through the tee or wye placed in the sewer line for that purpose. No separate compensation shall be allowed the Contractor for connecting the existing lateral to new main.

Sewer laterals shall be constructed of a minimum of four-inch (4") PVC pipe. Residences shall not be allowed to share a common lateral. Each residence shall be served by an individual lateral.

Where existing lateral elevations dictate the rolling of tees or wyes 45 degrees in the vertical plane, the sewer lateral pipe shall be cut, and a 45-degree bend provided for vertical alignment of the new and existing sewer lateral.

Where existing sewer laterals are inactive, six-inch (6") PVC sewer pipes shall be extended to the right of way line at the depth of the existing laterals and plugged. The location of the lateral shall be referenced both horizontally and vertically by the Contractor.

The Contractor shall take particular care to keep sewer laterals clean of all dirt, mud and other obstructing matter.

No separate compensation shall be allowed the Contractor for work and materials required in maintaining temporary service of the existing sewer lateral to the old sewer line nor for handling sewage while connecting the existing lateral to the new main.

All pipe for laterals shall be marked within the right of way using a metalized tape buried between 18 and 24 inches below the ground surface. Tape shall be 3" wide minimum, Terra Tape, as manufactured by Griffolyn Company, Inc., Detectatape as manufactured by Allen Systems, Inc., or an approved equal. The pipe trench shall be backfilled to approximately 24 inches below the ground surface and then metalized tape shall be placed flat over top of pipe. Backfill shall be carefully placed to a depth of 3 inches by hand to assure that the tape is secured in place over the pipe. All laterals shall be marked at the street with an embedded metal rod inserted in the pavement or curbing. It is the intent of this paragraph to provide a means to locate sewer laterals using standard pipe location equipment. Tape shall be extended from the centerline of the sewer main to the end of the sewer lateral and approximately 2 feet of tape shall be neatly wrapped around a 1 x 2 strip of lumber at the end of the lateral at the right of way limits in locations where service is currently not required. Cost of marking sewer laterals shall be included in unit price bid for sewer pipe for stacks and laterals.

- F. Thrust Restraint for Force Mains: Thrust restraint for force mains at bends shall be provided by concrete thrust blocks, mechanical joint restraint, or a combination of both methods. Thrust blocks of concrete of a mix not leaner than one cement, two

fine aggregate and four coarse aggregate, having a compressive strength of not less than 3,000 psi shall be installed. The blocking shall be poured against undisturbed earth.

Mechanical joint restraints shall be of adequate strength to prevent movement shall be used to supplement concrete blocking where noted. Locked mechanical joint restraint shall be ductile iron equipped with ductile iron or stainless-steel screws. Assembly shall be designed for minimum pressure of 250 psi.

1.25 EMBEDMENT OF PVC GRAVITY SEWER PIPE

A. Embedment:

Except as modified hereinafter, embedment material for PVC gravity sewer pipe shall be either Class I, II, or III material as described in ASTM D2321. The table below shall be used in determining the material required for embedment, which may be referred to as "haunching," "foundation or bedding," and "initial backfill" as used in these specifications, of PVC gravity sewer pipe.

EMBEDMENT FOR PVC GRAVITY SEWER PIPE

Pipe Depth	Bedding or Foundation	Haunching	Initial Backfill
16' or less	C1. I, II, or III	C1. I, II, or III	C1. I, II, or III
Greater than 16'	C1. I or II	C1. I	C1. I, II or III

In areas where the existing soil is other than as described above and is not acceptable for use as embedment material, crushed stone or reef shell as herein before specified shall be used. Separate payment will be made for crushed stone or reef shell used for foundation or bedding and haunching under the items of "Crushed Stone Foundation" and "Haunching for PVC Sewer Pipe" respectively. There will be no payment for embedment material when existing material is utilized.

In areas where the pipe is below the water table or expected to be below the water table in the future, and the foundation or bedding material is Class I material, whether existing or as installed, crushed stone or reef shell shall be used for haunching of the pipe. Separate payment will be made for crushed stone or reef shell used for haunching of the pipe under the item of "Haunching for PVC Sewer Pipe."

B. Embedment materials listed here include a number of processed materials plus the soil types listed under the USGS Soil Classification System (FHA Bulletin No. 373). These materials are grouped into five broad categories according to the suitability for this application:

1. Class I - Angular, 6 to 40 mm (1/4 to 1-1/2 inch), graded stone, including a number of fill materials that have regional significance such as coral, slag, cinders, crushed stone, and crushed shells.
2. Class II - Coarse sands and gravels with maximum particle size of 40 mm (1-1/2 inch), including variously graded sands and gravels containing small percentages of fines, generally granular and non-cohesive, either wet or dry. Soil types GW, GP, SW and SP are included in this class.

3. Class III - Fine sand and clayey gravels, including fine sands, sand-clay mixtures, and gravel-clay mixtures. Soil types GM, GC, SM and SC are included in this class.
4. Class IV - Silt, silty clays, and clays including inorganic clays and silts of medium to high plasticity and liquid limits. Soil types MH, ML, CH, and CL are included in this class. These materials are not acceptable for bedding, haunching, or initial backfill.
5. Class V - This class includes the organic soils OL, OH, and PT as well as soils containing frozen earth, debris, rocks larger than 40 mm (1-1/2 inch) in diameter, and other foreign materials. These materials are not acceptable for bedding, haunching, or initial backfill.

#### 1.26 EMBEDMENT OF POLYETHYLENE SEWER PIPE

Embedment of polyethylene sewer pipe shall be used if it becomes necessary to replace a lateral where polyethylene sewer pipe liner is being installed.

Embedment material shall be Class 1 structural backfill, which shall be angular, 6 to 40 mm (1/4 to 1½ inches), graded stone, including a number of fill materials that have regional significance such as coral, slag, cinders, crushed stone, and crushed shells. Embedment shall be paid for a Class 1 structural backfill for polyethylene. Separate payment will be made for slag or crushed stone.

#### 1.27 BACKFILL

- A. Backfilling: Backfill material shall be free from rocks or boulders and shall be deposited in the trench simultaneously on both sides of the pipe for the full width of the trench in four-inch (4") layers to an elevation of at least 6 inches above the top of the barrels of the pipe. Material shall be dry enough to compact to the equivalent density of the surrounding earth. If too dry the backfill material shall be dampened. Backfill containing broken pavement shall not be used. Backfill shall be in four-inch (4") layers, tamped with hand tamps, to 6 inches above the top of the pipe. The remainder of the trench shall be backfilled in six-inch (6") layers and tamped with a mechanical tamper specifically manufactured for compacting backfill.
- B. Deficiency of Backfill, by Whom Supplied: Any deficiency in the quantity of material for backfilling the trenches, or for filling depressions caused by settlement, shall be supplied by the Contractor at no cost to the Owner.
- C. Backfill Under Pavement: Backfill under all existing or proposed pavement for street, driveways, sidewalks, or roadways up to the existing grade or proposed grade, whichever is lower, and to a minimum distance of ten (10) feet adjacent to existing or proposed pavement, shall be as specified elsewhere herein.

#### 1.28 INSTALLATION OF FORCE MAINS

Force mains shall be constructed to the alignment and depth required. Force mains 16 inches and larger shall have minimum cover of 48 inches, and force mains smaller than 16 inches shall have minimum cover of 30 inches, except where otherwise noted on the plans. The trench shall be braced and drained so that workmen may work safely therein. The width of the trench shall be at least 12 inches greater than the nominal diameter of the pipe and the maximum clear width of the trench shall be not more than 36 inches greater than the pipe diameter.

- A. Pipe Foundation: The trench shall have a flat bottom with bell holes of ample dimensions to allow jointing and so the barrel of the pipe will have a bearing for its full width.
- B. Pipe Laying: All pipe, fittings, etc., shall be lowered into the trench by means of derrick, ropes, or other suitable tools, and under no circumstances shall pipe be dropped into the trench. Any defective pipe shall be rejected.
- C. Jointing: Joints shall be installed in strict accordance with the recommendations of the pipe manufacturer.
- D. Thrust Blocks: At bends, thrust blocks of concrete of a mix not leaner than 1 cement, 2 fine aggregate and 4 coarse aggregate, having a compressive strength of not less than 3,000 psi shall be installed. The blocking shall be poured against undisturbed earth.
- E. Retainer Glands: Locked mechanical joint retainer glands of adequate strength to prevent movement shall be used to supplement concrete blocking where noted. Locked mechanical joint retainer glands shall be ductile iron retainer glands equipped with hardened, cupped end set screws. Assembly shall be designed for minimum pressure of 250 psi.
- F. Backfilling: Backfilling shall be as specified in Section 15 entitled "Backfilling."

#### 1.29 AIR AND VACUUM VALVES FOR FORCE MAINS

Sewage air and vacuum valves shall permit unrestricted passage of air during filling of the force main and unrestricted entry of air into the force main under vacuum condition. Float shall be stainless steel, and valve shall be designed so that the venting mechanism does not come into contact with sewage. Valves shall have NPT inlet and shall be fitted with back flushing device. The valve shall be installed in pit as shown on plans.

Sewage air and vacuum valves, short-bodied version, shall be on the Owners list of materials and approved manufacturers.

The valve shall be fitted to a minimum 18-foot length of ductile iron force main by means of a tapping saddle, Type 304 Schedule 40 stainless steel pipe, and bronze gate valve with hand wheel. Pit shall consist of 36-inch concrete pipe with cast iron cover as shown on the plans. Cover of pit shall be flush with ground. Depth of force main shall be sufficient to install air and vacuum valve.

#### 1.30 INSTALLATION OF FORCE MAIN VALVES

- A. Resilient Seated Gate Valves: All valves shall be non-rising stem for underground

direct burial service and shall close when operating nut is turned in clockwise rotation. Valves shall be in accordance with and meet the requirements and recommendations of AWWA C509. O-ring seals shall be provided. The valve shall be a compression resilient seated gate valve. Disc shall be SBR coated. Valve body shall be fusion-epoxy bonded inside and out. Valves shall be furnished complete with necessary gaskets, bolts, nuts as needed for mechanical joint ends. Mechanical joints and accessories shall comply with the latest published AWWA C111.

1. Valves (12 Inches and Smaller): Each valve shall have mechanical joint bell ends and shall be on the Owner's list of materials and approved manufacturers. Valve shall be installed with the operating stem in the vertical position. Valve stem shall be furnished with 2-inch square water works nut.

B. Check Valves: Check valves shall be silent check valves, globe type (for 3" or larger) or wafer type (for smaller than 3") and on the Owner's list of materials and approved manufactures. Silent check valves shall be manufactured with cast iron bodies conforming to ASTM A-126 Class B Standards, stainless steel non-wearing conical springs conforming to ASTM A-276, and bronze discs, seat rings, stem and guide bushings conforming to ASTM B-62. Swing check valves shall be constructed with flanged ends conforming to ANSI B16.1 for Classes 125 and 150, and ANSI B16b for Class 250.

#### 1.31 INFILTRATION

Leakage into the completed sewer main shall not exceed 50 gallons per mile of sewer per inch of inside diameter of the sewer per 24 hours in any section between successive manholes. The amount of leakage shall be measured by a suitable weir or other device. All equipment and labor for measuring the infiltration shall be furnished by the Contractor. If the infiltration exceeds the amount specified above, the Contractor shall make the necessary corrections to bring it within the acceptable limits. All visible leaks or points of infiltration shall be repaired even though the infiltration is below the maximum specified.

#### 1.32 AIR TESTING OF SANITARY SEWERS

A. General: On all sanitary sewer lines, including laterals, wherever possible and practical, the Contractor shall conduct a line acceptance test. The test shall be conducted after the pipe has been backfilled and the cost of testing shall be included in other items of work. Equipment to be used in making the test shall be specifically designed for this purpose. Air tests for gravity sewers shall include the use of Cherne Air-Lock Equipment, NB Products, Inc. equipment, or approved equal. The Engineer shall be advised at least 48 hours before tests are conducted.

B. Procedures: Sanitary sewer lines shall be tested by the following methods:

##### 1. Gravity Sanitary Sewer Lines

a. All pneumatic plugs shall be seal tested before being used in the actual test installation. One length of pipe shall be laid on the ground and sealed at both ends with the pneumatic plugs to be checked. Air shall be introduced into the plugs to 25 psig. The sealed pipe shall be pressurized to 5 psig. The plugs shall hold this pressure without



bracing and without movement of the plugs out of the pipe.

- b. After a manhole to manhole reach of pipe has been backfilled and cleaned, and the pneumatic plugs are checked by the above procedure, the plugs shall be placed in the line at each manhole and inflated to 25 psig. Low pressure air shall be introduced into this sealed line until the internal air pressure reaches 4 psig greater than the average back pressure of any groundwater that may be over the pipe. At least two minutes shall be allowed for the air pressure to stabilize. After the stabilization period (3.5 psig minimum pressure in the pipe), the air hose from the control panel to the air supply shall be disconnected. The test time required in minutes for the pressure to decrease from 3.5 to 2.5 psig (greater than the average back pressure of any groundwater that may be over the pipe) shall not be less than the time shown for the given diameters in the following table:

<u>Pipe Dia. in Inches</u>	<u>Minutes</u>
4	2.0
6	3.0
8	4.0
10	5.0
12	5.5
15	7.5
18	8.5
21	10.0
24	11.5

- c. In areas where groundwater is known to exist, the Contractor shall install a one-half inch (1/2") diameter capped pipe nipple, approximately ten (10) inches long, through a manhole wall on top of one of the sewer lines entering the manhole. This shall be done at the time the sewer line is installed. Immediately prior to the performance of the Line Acceptance Test, the groundwater shall be determined by removing the pipe cap, blowing air through the pipe nipple into the ground so as to clear it, and then connecting a clear plastic tube to the nipple. The hose shall be held vertically and measurement of the height in feet of water over the invert of the pipe shall be taken after the water has stopped rising in this plastic tube. The height in feet shall be divided by 2.3 to establish the pounds of pressure that will be added to all readings. (For example, if the height of water is eleven (11) feet, then the added pressure will be five (5) psig. The allowable drop of one (1) pound and the timing remain the same.) Other methods for determining groundwater level may be used if approved in advance and if results are expected to be accurate in determining the groundwater level.
- d. Should the line fail the pressure test, the Contractor shall, at his expense, determine the source of leakage and make repairs as necessary to eliminate leakage. Air testing shall be in addition to infiltration tests specified elsewhere herein.

- e. No direct payment will be made for air testing of sewers. Payment for this item shall be included in the unit price bid for the sewer pipe installed.

2. Sanitary Sewer Force Mains

All sanitary sewer force mains shall be tested as follows:

After the pipe has been laid and partially backfilled, all pipe with any and all services installed and connected or any valved section shall, unless otherwise specified, be subjected to a minimum hydrostatic pressure of 100 psi. The pressure test shall be for at least two hours or until the line has been completely inspected for visible leaks, whichever is longer. Before testing, all air shall be expelled from the line. The Contractor shall make all necessary taps to expel the air and then plug all taps watertight.

Approved and suitable means shall be provided by the Contractor for determining the quantity of water lost by leakage. No pipe installation will be accepted until or unless the leakage (evaluated on a pressure basis of 100 psi) is less than 25 U.S. gallons per 24 hours per mile of pipe per inch nominal diameter of pipe. Any observed leaks shall be repaired by the Contractor.

1.33 REMOVING AND REPLACING PAVEMENT

- A. General: All paved streets and other paved areas cut by these operations shall be repaved in a workmanlike manner as shown or specified. All work shall be performed in accordance with the Alabama State Highway Department's current standard specifications. Prior to excavation in paved street or other paved areas, the pavement shall be cut along straight and perpendicular lines parallel to the centerline of the pipe. Upon completion of the pipe laying, backfill shall be placed as required by these specifications. Immediately prior to repaving, jagged edges shall be squared and cut to a string line so that the pavement replacement will present a neat appearance. Centerline strips or other pavement markings which existed prior to the start of construction shall be replaced. No separate payment will be made for striping or marking.

The term "Pavement" shall be construed to mean either concrete, bituminous, cobblestones, or brick placed as wearing surface in streets, driveways, or sidewalks, or placed as slope protection for ditches or drains.

- B. Removing and Replacing Bituminous Base Course: Pipe trenches at paved surface crossings shall be backfilled with select or other stable material and compacted at near optimum moisture content to a minimum density of 95% of AASHTO T-99 placed evenly on each side of the pipe to the top of the subgrade elevation. Six inches (6") of an approved 4000 psi concrete mix and in accordance with the State of Alabama Highway Department Specifications, latest edition, shall then be constructed. For bituminous and concrete pavement replacement for street crossings, compaction tests shall be performed by a certified testing lab at two (2) foot increments vertically and at sufficient intervals along with trench to verify that density requirements have been achieved. Copies of certified lab reports shall be submitted to the Engineer, verifying that the backfill and base material meet the

requirements of the contract specifications. Immediately following the completion of the required backfill and concrete base trench construction, the top two (2) inches of the trench shall then be filled with a Superpave Bituminous Concrete Wearing Surface Mix 424, ESAL Range C with a maximum 1/2" aggregate size, flush with the road surface and continuously maintained for a period of one (1) to six (6) months, as directed by the Engineer.

- C. Bituminous Wearing Surface: The following procedure shall then be followed at the completion of the maintenance period for the Bituminous Base Course, as directed by the Engineer. Jagged edges shall be squared and cut to a neat line with an appropriate saw. The edges of the pavement shall be cut along straight lines parallel to the center of the pavement cut.

Upon completion of the repaired backfill and base course trench construction, a tack coat using SS1 or SS1h emulsified asphalt shall then be applied at a rate of 0.05 gallons per square yard to the full trench width. The bituminous flexible Pavement Wearing Layer, Mix 416-A, shall then be constructed at one hundred and twenty-five (125) pounds per square yard. It is intended for sanitary sewer mains in streets to be constructed in one lane and therefore requiring resurfacing of only one half of the existing street extending from the nearest edge to the center line. Care shall be taken to assure a smooth transition at each edge of pavement flush with the road surface at roadway crossing and at all other transition locations, as shown in the plan details.

After resurfacing, the Contractor shall warranty the pavement for two (2) years. Any pavement failure that occurs during this period shall be replaced at the Contractor's expense, including removing and replacing subgrade material, if necessary. Copies of certified lab reports verifying that the construction materials used meet the project specifications shall be submitted to the Engineer.

#### 1.34 EROSION AND PROPERTY CONTROL

Any existing sod or grass removed shall be replaced with new sod of the same type.

- A. Flow of Drains and Sewer Maintained: Adequate provisions shall be made for the flow of sewers, drains, and water courses encountered during construction and the lines and structures which may have been disturbed shall be immediately restored to their original condition at the expense of the Contractor.
- B. Property Protection: Trees, grass, fences, signboards, poles and all other property shall be protected unless their removal is authorized. Any property damage shall be satisfactorily restored by the Contractor at the expense of the Contractor.
- C. Erosion The Contractor shall at all times take necessary precautions to prevent erosion or transportation of soil due to natural or induced water flows. Spoil banks and soil stockpiles shall be contained to prevent transportation of soil by run-off waters.
1. Topsoil: As indicated on the plans or specifically required in the specifications, the final top surface (depth as specified) of soil within the specific area shall be a good quality topsoil which shall be material obtained from the striping operation and whatever additional topsoil required at the Contractor's cost from an off-site source. Topsoil shall be workable, friable,

loamy soil free from hard lumps, stiff clay, gravel, noxious weeds, brush and other deleterious materials. Lime shall be added to reduce the possibility of odor. Topsoil shall be placed in all areas disturbed by construction, prior to grassing. No direct payment will be made for topsoil unless specifically noted otherwise.

- a. Grading: The Contractor shall perform grading of every description regardless of the character of material encountered, within the limits and to the lines and grade shown on the plans. Slight changes in grades shown on the plans may be required to allow for final dressing and drainage as the work progresses. Sufficient topsoil shall be stockpiled for final dressing.
- b. Stripping: Stripping shall consist of the removal of a minimum of four inches of grass and topsoil from within the limits of the new construction as shown on the plans. Topsoil obtained from the stripping operation that meets or exceeds topsoil requirements of this section shall be stockpiled on the site in areas approved by the Owner. If any of the stripped material is not suitable for use as topsoil or embankment material, it shall be disposed of away from the construction site by the Contractor at no cost to the Owner.

2. Grassing and Mulching:

The trench lines and other areas disturbed by construction of sewer lines shall be grassed and mulched as hereinafter specified where indicated on the plans or where directed. These items are to be considered as special erosion control measures to be utilized only where specifically required and payment will be made only when these items are shown on the proposal or where Engineer authorization is granted. In all other areas, the provisions of paragraph entitled "Erosion and Property Control" of this section shall apply with respect to erosion control.

- a. General: After pipe trenches have been backfilled, the area to be grassed shall be graded to the final grade and roots, stumps, or other materials which might be harmful to grass growth shall be removed and disposed of. Care shall be taken to spread topsoil over the entire area to be grassed to the extent that topsoil along and adjacent to the trench lines is available.
- b. Fertilizer: After the surface has been prepared for grassing and before any grass or seeds are planted, the soil shall be loosened by harrowing or other approved methods, and the areas specified to be grassed shall be fertilized at a uniform rate of 1,500 pounds per acre with a standard commercial 8:8:8 fertilizer and 3,000 pounds of agricultural lime per acre.
- c. Seeding: The areas to be grassed shall be seeded with good sound seed in the following minimum quantities per acre:

Kentucky 31 Fescue 34 pounds  
Common Bermuda 10 pounds  
White Dutch Clover 10 pounds

In some areas, it may be necessary to vary the concentrations of various seed to suit local conditions and the Owner reserves the right to change proportions of the various seed so long as the total amount of seed does not exceed 74 pounds per acre at no change in contract price.

Seed shall be broadcast with hand operated equipment. When broadcast, seed shall be sown over the areas and raked or dragged and covered to the desired depth. Hydro seeding may, at the Contractor's option, be used in lieu of the above.

Unless specifically noted otherwise, Pensacola Bahia shall not be used.

- d. Mulching: In areas directed by the Owner, the surface of sprigged and overseeded slopes of the roadway or embankments shall be protected by the application of a mulch. The mulch shall be spread uniformly in a continuous blanket by hand or by suitable approved equipment, at a rate of two tons to the acre. Mulching material which, in the opinion of the Engineer, is too coarse or too short for proper securing in the surface soil will be rejected. Mulching shall be started at the windward side of relatively flat areas or at the upper part of a steep slope and continued uniformly over the entire area. The mulch material shall be anchored to the soil by spraying a light coating of emulsified asphalt over the straw or hay after these materials have been placed. The asphalt shall be applied by hand sprayers attached by hoses to an asphalt spreader or other approved methods. The asphalt adhesive shall be applied to the mulch at a rate of 150 gallons of undiluted (straight emulsion) asphalt per ton of straw or hay (300 gallons per acre). If the straight emulsion is further diluted with water in the ratio of 60 (straight emulsion) to 40 (water), the application rate shall be 250 gallons of asphalt emulsion per ton of straw or hay (500 gallons per acre). This will secure the mulch on the ground to form a soil binding mulch and prevent loss or bunching by wind or water.

- e. Maintenance: the Contractor shall maintain all grassed areas until acceptance of the entire contract and for a period of three months thereafter. Areas upon which an established stand of grass is not obtained, the Contractor shall reseed and re-mulch as hereinafter

specified. A satisfactory stand of grass is defined as a cover of living grass in which gaps larger than 12 inches do not occur at the time of acceptance. Maintenance shall consist of watering, preserving, protecting, replacing dead grass, filling washes and generally maintaining the area until final acceptance.

If the grassing operation is accomplished after the month of August or before the month of March, in addition to the seeding as outlined above, the entire grassed areas shall also be over seeded with Italian Rye Grass seed at the uniform rate of 40 pounds per acre at no additional cost to the Owner.

- f. Asphaltic Adhesive: Asphalt shall be a bituminous soil cover suitable for mulching of seeded areas and shall contain no petroleum solvents or other diluents which would be toxic to plant growth. It shall be a homogenous emulsification of especially refined petroleum asphalt suitable for spray application with or without dilution with water. Laykoid Soil Cover, manufactured by American Bitumuls and Asphalt Company, or other commercial types of asphalt specifically designed for mulching of seeded areas for erosion protection against rain or wind, will be acceptable. Cost of this item shall be included in unit price bid for grassing and mulching for erosion control.

D. Erosion Control Netting: Erosion control netting shall be utilized in locations where specifically required by the engineer and installed in accordance with the manufacturers recommendation using 3/4 inch x 2 1/2 inch x 12 inch wedge shaped wooden stakes and/or staples. The netting material shall be Enkamat 7220 or engineer approved equal.

1. Construction Requirements: All surfaces to be protected shall be graded, fertilized, limed, and finished so as to be stable and firm.

Synthetic mat used as a ditch liner shall be applied with the length of roll laid parallel to the flow of the water. Where more than one width is required, a multi-width welded mat shall be supplied in multiples of 3 feet. All lap joints and upslope edges shall be staked at intervals of 3 feet or less. Where three-wide mat is required, lap joints to be limited to one every nine feet of width.

All wood stakes shall be driven to within 2 inches of the ground surface.

An anchor slot shall be placed at the upslope and downslope ends of the mat placement. At least 12 inches of the end of the mat shall be buried vertically in a slot dug in the soil. The mat shall be secured in the anchor slot by staples or stakes at intervals of 3 feet or less prior to burying, except when the ditch is located above the synthetic liner, in which case no stakes or staples shall be used in the anchor slot unless 6 inches separation is maintained between the point of the installed stake or staple, and the synthetic liner. The soil shall be firmly tamped against the mat in the slot.

Successive lengths of mat shall be overlapped at least 3 feet, with the upstream length on top. Stake or staple the overlap in 3 places evenly spaced across the end of each of the overlapping lengths and in 3 places across the width of the center of overlap area. Check slots shall be spaced so that a check slot occurs within each 20 feet. Stake or staple the mat in the check slot at each edge overlap and in the center of the mat, except when the ditch is located above the synthetic liner, in which case no stakes or staples shall be used in the check slot, unless 6 inches separation is maintained between the point of the installed stake or staple and the synthetic liner. Beginning and terminal ends to be staked in accordance with installation manual.

Upslope edges of mat used as ditch lining shall terminate on 4-inch-wide horizontal shelves running parallel to the axis of the ditch for the full length of the ditch. Edges of the mat shall be staked at 3-foot intervals, backfilled with soil, and tamped to original slope.

After the mat has been placed, the area shall be evenly seeded or sodded, as specified and where shown on the plans.

Synthetic liner damaged by the contractor during mat installation shall be repaired immediately.

The Contractor shall maintain the blanket until all work on the contract has been completed and accepted. Maintenance shall consist of the repair of areas where damaged by any cause.

2. Method of Measurement: Synthetic mat, including stakes and staples, complete in place and accepted, will be measured by the square yard of finished surface. Material placed outside the specified limits will not be measured or paid for and the contractor may be required to remove and dispose of the excess material without cost to the City.

### 1.35 CLEAN-UP

Where these operations are on City, State, County or Private Property, the construction area shall be kept clean at all times. Loose dirt shall not be allowed to clog ditches or cover sidewalks. Soft clay or other undesirable material removed from the trenches shall be removed from the streets, sidewalks or ditches. The Owner reserves the right to demand that the Contractor's forces be diverted to this clean-up at any time that condition of streets, driveways, sidewalks, or private property warrants such diversion. Such diversion of Contractor's forces will not entitle the Contractor to any extension of time or additional compensation.

### 1.36 USE OF CHEMICALS

All chemicals used during project construction or furnished for project operation, whether herbicide, pesticide, disinfectant, polymer, reactant or of other classification, must show approval of either EPA or USDA. Use of all such chemicals and disposal of residues shall be in strict conformance with manufacturer's instructions.

### 1.37 PERMITS, CERTIFICATES, LAWS AND ORDINANCES

The Contractor shall, at his own expense, procure all permits, certificates and license s required of him by law for the execution of his work. He shall comply with all Federal, State, or Local laws, ordinances, or rules and regulations relating to the performance of the work.

### 1.38 UNDERGROUND UTILITIES

The plans show certain features of topography, and certain underground utilities, but they do not purport to show in complete detail all such lines or obstructions. Such topography and notes on the plans were inserted from records available and are for the Contractor's convenience only, and shall not be used as the basis for claims of extra compensation. Whenever necessary to determine the location of existing pipes, valves, or other underground structures, the Contractor shall examine all available records and shall make all explorations and excavations for such purpose. Any damage to existing facilities resulting from the Contractor's operations shall be immediately repaired by the Contractor at no cost to the Owner.

1.39 SHOP DRAWINGS AND RECORD DRAWINGS

The Contractor shall submit to the Engineer for review and approval prior to ordering materials six (6) sets of shop drawings for valves, fittings, special connection fittings, and piping at connections to existing pipes. No separate compensation will be allowed the Contractor for Shop Drawings. Review and approval of Shop Drawings by the Engineer shall in no way relieve the Contractor of his responsibilities for materials and workmanship in construction of the project. Upon project completion, two (2) sets of record drawings shall be submitted to the building inspector showing final construction conditions noting installed materials and locations.

To assure that manufacturers and suppliers are aware of the use to which their equipment and products will be subjected, the Contractor shall require the manufacturer or manufacturer's representative to place the following certification on submittal data transmittals:

"This is to certify that we have examined the Plans and Specifications for this Project and have ascertained that this equipment or material is suitable for the purpose and use intended.

\_\_\_\_\_  
Authorized Signature

1.40 ABANDONED SEWER MAINS AND APPURTENANCES

The Owner shall retain ownership of all salvageable material removed from the project. The Contractor shall neatly store these materials at locations designated by the Engineer. The cost of removing and storing these materials as directed will be borne by the Contractor with no direct payment. Any material deemed unsalvageable by the Engineer or that is not wanted by the Owner shall become the property of the Contractor and removed from the work site for no additional compensation.

1.41 PRECONSTRUCTION PHOTOGRAPHS

Prior to start of clearing, grubbing, and excavation for water lines, a photograph shall be taken at 100 feet on centers by a commercial photographer using a wide-angle lens or of the entire project using a VHS video camera. The photograph(s) shall be taken along the centerline of the project looking up station and at least one station marker shall be visible in each photograph for identification purposes. Station markers shall be set by the Contractor. Each photograph shall be further identified on the back and video tapes shall be marked on the tape casing with project number, location, date and time of day that photograph was taken. One color print approximately 5" x 7" and the negative or one (1) color VHS video tape shall be delivered to the Engineer within one week after photograph is made. Additional supplemental photographs shall be required should areas requiring special attention be encountered. No direct payment will be made for photographic work.

1.42 INTERNAL VIDEO INSPECTION

A. General: The Contractor shall furnish a mobile television inspection studio, all television equipment including a pan and tilt color camera and other necessary types of equipment, and all materials, electricity, labor, technicians, etc., as may be needed to perform the closed-circuit television inspection of sanitary sewers for the purpose of documenting deficiencies and lateral locations prior to construction. A



recorded verbal narrative shall coincide with the video. At each lateral or defect the camera shall stop and pan and tilt perpendicular to the lateral or defect and a recorded verbal narrative shall describe the lateral or defect. Location within the pipe shall be shown in 0.1 foot increments on the video recording and shall have an accuracy of +/- one (1) foot. The location shall be referenced, or "zeroed", at the manhole in which the recording is started, and in all subsequent manholes if multiple segments are videoed at the same time. Re-videoing of the pipe will be required if the specified accuracy is not met. No work is authorized under this Section unless a representative from the City of Fairhope is present or has been notified 24 hours prior.

B. Inspection Procedures: The inspection shall be performed by pulling the television camera through the section of the sewer along the axis of the pipe. The sanitary service connections shall not be bypassed while video inspection is being completed.

C. Documentation: Documentation of the internal inspection results shall be as follows:

1. Normal Internal Inspection Records: The Contractor shall keep a daily log or record of the television inspection work and the information acquired therefrom. The record shall include the following:

- Date and Time of inspection
- Contract Number and Name
- Name of Engineering Firm
- Name of Contractor
- Name of Internal Video Inspection Company
- Name of Street
- I.D. Number of Upstream and Downstream Manholes
- Description of the Location
- Direction of the Video
- Size, Length, Depth, and Type of Pipe
- Distance, Position, Type, and Description of all Laterals and Defects
- Computer Generated Sketch of Pipe with Lateral and Defect Location, Type, and Distance from Manholes

Two copies of the log or record, typed and bound, shall be delivered to the

Owner. A copy of the log or record and a summary shall be included in the Final Project Report in the same sequential practical order as the related videotape.

2. Videotape:

General: The purpose of the videotape recordings shall be to supply a continuous visual and audio record of the inspection using a VHS video cassette system. The Contractor shall fill each VHS videotape as much as practical to minimize the number of tapes submitted. All sections of videotaped runs shall be recorded on one tape. Videotaped runs shall be grouped in Areas and submitted in sequential order relating to the Area designation. The accuracy and completeness of the video shall be warranted. When the Owner finds inaccuracies in the video during the warranty period, the Contractor shall re-video the line at no expense to the Owner.

Videotape recordings shall be enclosed in vinyl plastic containers which shall clearly indicate the date the tape was taken, and the designated section(s) of sewer line(s) contained on the tape and provide to the owner with the invoice.

3. Major Defects

General: The Contractor shall notify the Owner within 24 hours of discovering a major defect in the sanitary sewer main that will require a point repair to correct the defect. The Contractor shall provide a sketch to the Owner on an 8 ½" x 11" paper that shows the sanitary sewer main and the location of the defect. Distances from manholes to the defect shall be provided on the sketch along with a detailed description of the defect.

STANDARD SPECIFICATIONS FOR CONSTRUCTING  
SANITARY SEWER FACILITIES

DIVISION III - CONSTRUCTION SPECIFICATIONS  
SECTION 2

GENERAL SPECIFICATIONS FOR SEWAGE PUMPING STATION

2.01 SCOPE:

These Specifications form a part of the Contract Documents and shall govern for the construction of sewage pumping stations. The Work covered by this Section includes the furnishing of all labor, equipment, and materials, and performing all operations in connection with the construction and installation of Sewage Pumping Stations complete with pumps, piping, wet well, electrical work and all necessary auxiliary equipment. The station shall be complete and in strict accordance with this section of the specifications and the applicable plans, the standard practices and ordinances of the City of Fairhope, Alabama, and subject to the terms and conditions of the Contract. Sewage pumping stations shall be designed to remain fully operational and accessible during a one hundred (100) year flood event.

2.02 MATERIALS:

Materials of this Section shall be as specified herein.

2.03 INTENT OF PLANS AND SPECIFICATIONS:

The intent of the plans and specifications associated with this Section is to provide a completed sewage pumping station which will function as intended and is ready for operation in accordance with the City of Fairhope standard practices.

It shall be the responsibility of the Contractor as a part of this Work through careful quality control and coordination with the Engineer to avoid all conflicts occurring during construction such as available space, routings, mismatched or otherwise incompatible component selection, incomplete systems, substitutions, etc.

Where inter-system components, devices, adapters, etc. are not specified or noted in the design, but required to complete the system, it shall be the responsibility of the Contractor to provide such items and material as a part of this Work.

Unless otherwise noted, items specified herein by manufacturer or trade name shall be used as a guide to quality and inherent features.

Special drawings and specifications shall be submitted by the Contractor for the Engineer's evaluation covering all equipment, controls, material, and construction procedures.

The actual field installation shall reflect only that material and equipment submitted and approved by the Engineer/Owner. Any work performed without an approved submittal and considered not acceptable by the Engineer shall be removed and reworked at the Contractor's expense.

## 2.04 SUBMITTALS AND TESTS:

### A. Submittals:

Prior to installation of any material or equipment, the Contractor shall submit for approval of the Engineer, five sets of required submittal material indicating item identification, manufacturer, type, size, ratings, and other descriptive information required for adequate evaluation. Pumps submittals should include Catalog cuts sheets reflecting characteristics for major items of equipment, materials of construction, major dimensions, motor and v-belt drive data, pump characteristic curves showing the design duty point capacity (GPM), head (FT), net positive suction head required (NPSH), and hydraulic brake horsepower (BHP). Electrical components used in the motor branch and liquid level control shall be fully described.

Submittal drawings shall provide layout of mechanical equipment and anchor bolt locations for station. Contractor piping connections and station access clearances shall be dimensioned relative to the station centerline. The electrical ladder logic drawings shall illustrate motor branch and liquid level control circuits to extent necessary to validate function and integration of circuits to form a complete working system. Wiring diagrams shall be submitted where item function description necessitates, and as required by the Engineer. Submittals shall be conspicuously marked to denote departures from the design references shown on the plans or specified. Incomplete submittals will not be evaluated.

Submittals shall bear a stamp or specific written indication that the Contractor has satisfied his responsibilities under the Contract with respect to the Contractor's review of the submission.

Omissions and/or design revisions made in submittals shall not relieve the Contractor from the responsibility of providing the omitted item or required material as a part of this Work. Approval by the Engineer shall not constitute acceptance of an erroneous or incomplete system submittal.

1. Material submittals shall be manufacturer's catalog sheets or similar published data marked to denote only the item or items covered by the submittal. Materials of unique production shall have special submittal attention to give complete identification of the materials being proposed.
2. Equipment submittals shall present the equipment for evaluation as a unit piece including all component parts by manufacturer's designation. Submittals shall be marked to denote only the equipment being proposed and shall be complete including electrical, physical, and operational data. Additional supporting data shall be provided where necessary.
3. Fabrications assemblies, and special productions shall have submittals of unique preparation to present the finished item completely identified. Such shop drawings shall include all material, components and assembly work.
4. Systems composed of multiple component parts or subsystems shall have submittals to denote the system as a completed composite. All component parts and subsystems shall be identified.

5. Documentation of the finished installation shall be made as a part of final acceptance and shall include corrected submittals, operation and maintenance publications, and other data necessary to accurately define the final field installation.

B. Tests, Instructions and Reports:

The following listed items shall be required in addition to other special requirements within these Specifications.

1. Written conductor insulation resistance test.
2. Written ground rod resistance test.
3. Local public electrical inspector's certificate.
4. Operational demonstration test.
5. Certified pump curves.
6. Operation and maintenance manuals.

2.05 SITE WORK:

In general, clearing shall consist of the removal and disposal of all undergrowth, brush, logs, trash and other objectionable obstructions. All materials cleared from the site shall be disposed of off the site by the Contractor. It is the intent that the entire area within the limits of the sewage pumping stations as shown on the plans shall be cleared, backfilled, and graded with four (4) inches of crushed stone surfacing for proper storm water drainage in accordance with the specifications contained herein. All areas surrounding the sewage pumping station shall be grassed.

- A. Access Driveways: The Contractor shall include in the sewage pumping station construction a Bituminous Pavement Access Driveway including select backfill, eight (8) inches of crushed aggregate, and one and a half (1½) inches of Bituminous Wearing Surface Mix 416-A. These access driveways shall be constructed in accordance with the Alabama Department of Transportation Standard Specifications, latest edition.
- B. Fencing: The Contractor shall include in the sewage pumping station construction a six (6) foot high wood privacy fence. The wood privacy fence shall be constructed of first class wood to the lines indicated on the plans and shall include treated 4" x 4" wood posts set a minimum of 36 inches deep in the ground in concrete and spaced no greater than 8 feet on center, three (3) treated 2" x 4" wood stringers between each set of posts, treated number 2 pine or better 6" x 3/4" fence boards with dog eared tops, galvanized fasteners and hardware, 12 foot double leaf swing type heavy duty service traffic gate matching the fence, and a brass weatherproof padlock (4-pin tumbler type, minimum) and keys.
- C. Water Service: One (1) each 3/4" water service with hose bibb shall be located within the fenced area.

2.06 EXCAVATION FOR PIPES AND STRUCTURES:

- A. General: The Contractor shall perform excavation of every description regardless of the nature of the materials encountered. Trenches or foundations for pipes or structures shall be excavated to the lines, grades, and elevations shown on the plans. Trench and structure excavations shall be of sufficient size to permit the placing of pipes and forms.
- B. Overcuts: If at any point in excavating for structures, material is excavated beyond the neat lines upon or against which concrete is to be placed, the overcut shall be filled with reef shell, crushed slag or crushed stone fill properly compacted, or with concrete, as directed by the Engineer. The proposed elevations and positions for the different structures are shown on the plans. However, the Engineer reserves the right to make such modifications as in his opinion are necessary to carry out the intent of the plans or specifications. No payment will be made for overcuts or reef shell, crushed slag or crushed stone fill in overcuts. Reef shell, crushed slag or crushed stone shall be as specified in the Board's Standard Specifications.
- C. Dewatering: The Contractor shall remove any water which may be found or may accumulate in the trenches and shall perform all work necessary to keep them clear of water while the foundations are being laid, the masonry being constructed, or pipe laying is in progress. Such removal shall be accomplished by means of a well point system or other approved means. Comprehensive plans for dewatering operations, if used, shall be submitted prior to installation. No extra payment will be made for dewatering.

2.07 CONCRETE:

The minimum compressive strength required at 28 days is 3,000 pounds per square inch. Field specimens and laboratory tests shall be made in accordance with the standards of the American Society of Testing Materials. The minimum amount of water shall be used to produce a workable mix and shall not exceed six U.S. gallons per sack of cement. Concrete and associated materials shall also be in accordance with those specified for manhole structures.

2.08 WET WELL:

The foundation of the wet well shall consist of a reinforced concrete slab poured on undisturbed earth in accordance with details shown on the plans.

The barrel of the wet well shall be constructed of sections of reinforced concrete pipe conforming to ASTM 3 Specification Designation C76, Class II. Concrete for pipe shall be Type II Portland Cement with 100 percent calcareous aggregate.

The diameter, height, opening and other details shall be as shown on the plans.

Joints shall be made with rubber gaskets or an approved equal.

The wet well concrete interior shall be coated with a lining material in accordance with the manhole lining methods and products approved by the City of Fairhope. Lining shall be performed in accordance with the lining product manufacturer's recommendations.

Alternative wet well material, such as fiberglass, must be preapproved by the City of Fairhope dependent upon type, water table, and depth.

2.09 CONTINUITY OF OPERATIONS:

The Contractor, as a part of this work, shall provide all stand-by facilities, power systems, etc. in order to maintain the operations of existing facilities throughout the construction phases of the new work. The Contractor shall schedule his work with that of the Owner in order to coordinate all interruptions of the existing facilities operations to suit the Owner's schedule. All temporary facilities and provisions shall be made after being submitted to the Owner and approved thereby.

2.10 ELECTRIC POWER METERING:

The Contractor shall provide all labor and materials required for a complete installation to meter electrical power usage in accordance with the power company's detailed requirements. Meter location shall be as shown on the plans.

The Contractor, at his own expense, shall provide power and all necessary temporary wiring as required to perform his work. After completion of the permanent electrical connections, the Contractor shall be required as a part of this work to secure all utility services from the respective utility companies and shall pay all monthly bills until such time as acceptance of the equipment is made by the Owner. Upon acceptance, the Contractor can have the respective utility companies transfer their billing to the Owner's name.

2.11 ELECTRICAL SERVICE:

When required and as instructed by the Owner, the Contractor shall request three-phase power service from the utility company and shall make arrangements for the utility company to bill the Owner directly for any installation charges, other than those associated with power metering, for the service.

2.12 DEFINITION OF ACCEPTANCE:

System acceptance shall be defined as the point in time in addition to the requirements of Section 5 when all of the following requirements have been fulfilled:

- A. All submittals and documentation have been submitted, reviewed and approved.
- B. Two (2) copies of all Operations and Maintenance Manuals shall have been submitted on all equipment items.
- C. The complete system has successfully completed all testing requirements.
- D. All fees, permits, and reports have been satisfactorily completed.
- E. All Owner's staff personnel training programs have been completed.
- F. Beneficial use by the Owner has occurred following the two-year warranty period.

2.13 CLEAN-UP:

After final operation tests, the interior and exterior of the station shall be cleared of all trash and debris and left in final operating condition. Final grading of the site and restoration of surfaces with grass shall be in strict accordance with the applicable drawings.

2.14 SELF-PRIMING PUMPS:

- A. Where design conditions allow for self-priming pumps, and approved by owner, this type of pump can be installed. All self-priming pumps of the same type, frame and size shall be of the same manufacturer and shall have interchangeable parts and shall be a type and brand listed as approved by the City of Fairhope, Alabama. The station shall be complete with all equipment specified herein, factory assembled on a common steel base.
- B. Pumps shall be horizontal, self-priming centrifugal type, designed specifically for handling raw, unscreened, domestic sanitary sewage. Principal items of equipment shall include two horizontal, self-priming, centrifugal sewage pumps, V-belt drives, motors, piping, valves, motor control panel, automatic liquid level control system, and integral wiring.
- C. Pumps must be designed to handle raw, unscreened, domestic sanitary sewage. Pumps shall have properly sized suction and discharge connections. Each pump shall be selected to perform under following operating conditions:

Capacity (GPM)	_____
Total Dynamic Head (FT)	_____
Total Dynamic Suction Lift (FT)	_____
Maximum Repriming Lift (FT)	_____
Minimum TDH (FT)	_____
Maximum TDH (FT)	_____
Maximum Static Suction Lift (FT)	_____
Total Discharge Static Head (FT)	_____
Minimum Submergence Depth (FT)	_____

- D. Site power furnished to pump station shall be in accordance with the City of Fairhope's standard for phase, hertz, volts, and wire. Control voltage shall not exceed 128 volts.
- E. Operations Maintenance Manuals: Installation shall be in accordance with written instructions provided by the pump station manufacturer. Comprehensive instructions supplied at time of shipment shall enable personnel to properly operate and maintain all equipment supplied. Content and instructions shall assume operating personnel are familiar with pumps, motors, piping and valves, but lack experience on exact equipment supplied.

Documentation shall be specific to the pump station supplied and collated in functional sections. Each section shall combine to form a complete system manual covering all aspects of equipment supplied by the station manufacturer. Support data for any equipment supplied by others, even if mounted or included in overall station design, shall be provided by those supplying the equipment. Instructions shall include the following as a minimum:

1. Functional description of each major component, complete with operating instructions.
2. Instructions for operating pumps and pump controls in all modes of operation.



3. Calibration and adjustment of equipment for initial start-up, replacement of level control components, or as required for routine maintenance.
  4. Support data for commercially available components not produced by the station manufacturer, but supplied in accordance with the specifications, shall be supported by literature from the prime manufacturer and incorporated as appendices.
  5. Electrical schematic diagram of the pump station circuits shall be in accordance with NMTBA and JIC standards. Schematics shall illustrate, to the extent of authorized repair, pump motor branch, control and alarm system circuits including interconnections. Wire numbers and legend symbols shall be shown. Schematic diagrams for individual components, not normally repairable by the station operator, need not be included. Details for such parts shall not be substituted for an overall system schematic. Partial schematics, block diagrams, and simplified schematics shall not be provided in lieu of an overall system diagram.
  6. Mechanical layout drawing of the pump station and components, prepared in accordance with good commercial practice, shall provide installation dimensions and location of all pumps, motors, valves and piping.
  7. Operation and maintenance instructions which rely on vendor cut-sheets and literature which include general configurations, or require operating personnel to selectively read portions of the manual shall not be acceptable. Operation and maintenance instructions must be specific to equipment supplied in accordance with these specifications.
- F. The manufacturer of the pump station shall have a quality management system in place and shall be ISO 9001 certified. The pump station system integrator shall have a quality management system in place and shall be ISO 9001 certified.
- G. All internal passages, impeller vanes, and recirculation ports shall pass a 3" (2.5" on 3" pumps) spherical solid. Smaller internal passages that create a maintenance nuisance or interfere with priming and pump performance shall not be permitted. Upon request from the engineer, manufacturer's certified drawings showing size and location of the recirculation port(s) shall be submitted for approval.
- H. Reprime Performance:
1. Consideration shall be given to the sanitary sewage service anticipated, in which debris is expected to lodge between the suction check valve and its seat, resulting in the loss of the pump suction leg, and siphoning of liquid from the pump casing to the approximate center line of the impeller. Such occurrence shall be considered normal, and the pump must be capable of automatic, unattended operation with an air release line installed.
  2. During unattended operation, the pump shall retain adequate liquid in the casing to ensure automatic repriming while operating at its rated speed in a completely open system. The need for a suction check valve or external priming device shall not be required.

3. Pump must reprime the necessary vertical feet at the specified speed and impeller diameter. Reprime lift is defined as the static height of the pump suction above the liquid, while operating with only one-half of the liquid remaining in the pump casing. The pump must reprime and deliver full capacity within five minutes after the pump is energized in the reprime condition. Reprime performance must be confirmed with the following test set-up:
  - a. A check valve to be installed downstream from the pump discharge flange. The check valve size shall be equal (or greater than) the pump discharge diameter.
  - b. A length of air release pipe shall be installed between pump and the discharge check valve. This line shall be open to atmosphere at all times duplicating the air displacement rate anticipated at a typical pump station fitted with an air release valve.
  - c. The pump suction check valve shall be removed. No restrictions in the pump or suction piping will prevent the siphon drop of the suction leg. Suction pipe configuration for reprime test shall incorporate a 2 feet minimum horizontal run, a 90-degree elbow and vertical run at the specified lift. Pipe size shall be equal to the pump suction diameter.
  - d. Impeller clearances shall be set as recommended in the pump service manual.
  - e. Repeatability of performance shall be demonstrated by testing five consecutive reprime cycles. Full pump capacity (flow) shall be achieved within five minutes during each cycle.
  - f. Liquid to be used for repriming test shall be water.
4. Upon request from the engineer, certified reprime performance test results, prepared by the manufacturer, and certified by a registered professional engineer, shall be submitted for approval prior to shipment.
- I. Factory System Test: All components including the pumps, motors, valves, piping and controls will be tested as a complete working system at the manufacturer's facility. Tests shall be conducted in accordance with Hydraulic Institute Standards at the specified head, capacity, rated speed and horsepower. Factory operational test shall duplicate actual performance anticipated for the complete station.

The manufacturer's technical representative shall inspect the completed installation, correct or supervise the correction of any defect or malfunction, and instruct operating personnel in the proper operation and maintenance of the equipment as described in Part 3 of this section.

- J. Unit Base: The unit base shall comprise a base plate, perimeter flange, and reinforcements. Base plate shall be fabricated of steel not less than 1/4" thick and shall incorporate openings for access to all internal cavities to permit complete grouting of unit base after installation. Perimeter flange and reinforcements shall be designed to prevent flexing or warping under operating conditions. Base plate and/or flange shall be drilled for hardware used to secure unit base to concrete pad as shown on the contract drawings. Unit base shall contain provisions for lifting the complete pump unit during shipping and installation.
- K. Materials and Construction Features:
1. Pump casing: Casing shall be cast iron Class 30 with integral volute scroll. Casing shall incorporate following features:
    - a. Mounting feet sized to prevent tipping or binding when pump is completely disassembled for maintenance.
    - b. Fill port cover plate, 3 1/2" diameter, shall be opened after loosening a hand nut/clamp bar assembly. In consideration for safety, hand nut threads must provide slow release of pressure, and the clamp bar shall be retained by detente lugs. A Teflon gasket shall prevent adhesion of the fill port cover to the casing.
    - c. Casing drain plug shall be at least 1 1/4" NPT to insure complete and rapid draining.
    - d. Liquid volume and recirculation port design shall be consistent with performance criteria specified herein.
  2. Cover plate: Cover plate shall be cast iron Class 30. Design must incorporate following maintenance features:
    - a. Retained by hand nuts for complete access to pump interior. Cover plate removal must provide ample clearance for removal of stoppages, and allow service to the impeller, seal, wear plate or check valve without removing suction or discharge piping.
    - b. A replaceable wear plate secured to the cover plate by weld studs and nuts shall be AISI 1015 HRS.
    - c. In consideration for safety, a pressure relief valve shall be supplied in the cover plate. Relief valve shall open at 75-200 PSI.
    - d. Two O-rings of Buna-N material shall seal cover plate to pump casing.
    - e. Pusher bolt capability to assist in removal of cover plate. Pusher bolt threaded holes shall be sized to accept same retaining cap screws as used in rotating assembly.
    - f. Easy-grip handle shall be mounted to face of cover plate.

3. Rotating Assembly: A rotating assembly, which includes impeller, shaft, mechanical shaft seal, lip seals, bearings, seal plate and bearing housing, must be removable as a single unit without disturbing the pump casing or piping. Design shall incorporate following features:
- a. Seal plate and bearing housing shall be cast iron Class 30. Separate oil filled cavities, vented to atmosphere, shall be provided for shaft seal and bearings. Cavities must be cooled by the liquid pumped. Three lip seals will prevent leakage of oil.
    - 1) The bearing cavity shall have an oil level sight gauge and fill plug check valve. The clear sight gauge shall provide easy monitoring of the bearing cavity oil level and condition of oil without removal of the fill plug check valve. The check valve shall vent the cavity but prevent introduction of moist air to the bearings.
    - 2) The seal cavity shall have an oil level sight gauge and fill/vent plug. The clear sight gauge shall provide easy monitoring of the seal cavity oil level and condition of oil without removal of the fill/vent plug.
    - 3) Double lip seal shall provide an atmospheric path providing positive protection of bearings, with capability for external drainage monitoring.
  - b. Impeller shall be ductile iron, two-vane, semi-open, non-clog, with integral pump out vanes on the back shroud. Impeller shall thread onto the pump shaft and be secured with a lock screw and conical washer.
  - c. Shaft shall be AISI 4140 alloy steel unless otherwise specified by the Engineer, in which case AISI 17-4 pH stainless steel shall be supplied.
  - d. Bearings shall be anti-friction ball type of proper size and design to withstand all radial and thrust loads expected during normal operation. Bearings shall be oil lubricated from a dedicated reservoir. Pump designs which use the same oil to lubricate the bearings and shaft seal shall not be acceptable.
  - e. Shaft seal shall be oil lubricated mechanical type. The stationary and rotating seal faces shall be tungsten titanium carbide alloy. Each mating surface shall be lapped to within three light bands flatness (35 millionths of an inch), as measured by an optical flat under monochromatic light. The stationary seal seat shall be double floating by virtue of a dual O-ring design; an external O-ring secures the stationary seat to the seal plate, and an internal O-ring holds the faces in alignment during periods of mechanical or hydraulic shock (loads which cause shaft deflection, vibration, and axial/radial movement). Elastomers shall be Viton. Cage and spring to be AISI 316 stainless steel. Seal shall be oil lubricated from a dedicated reservoir. The same oil shall not lubricate both shaft seal and shaft

bearings. Seal shall be warranted in accordance with requirements specified herein.

- f. Pusher bolt capability to assist in removal of rotating assembly. Pusher bolt threaded holes shall be sized to accept same cap screws as used for retaining rotating assembly.
- 4. Adjustment of the impeller face clearance (distance between impeller and wear plate) shall be accomplished by external means.
  - a. Clearances shall be maintained by external shimless cover plate adjustment, utilizing collar and adjusting screw design for incremental adjustment of clearances by hand. Requirement of realignment of belts, couplings, etc., shall not be acceptable. Cover plate shall be capable of being removed without disturbing clearance settings.
  - b. There shall be provisions for additional clearance adjustment in the event that adjustment tolerances have been depleted from the cover plate side of the pump. The removal of stainless-steel shims from the rotating assembly side of the pump shall allow for further adjustment as described above
  - c. Clearance adjustment which requires movement of the shaft only, thereby adversely affecting seal working length or impeller back clearance, shall not be acceptable.
- 5. Suction check valve shall be molded Neoprene with integral steel and nylon reinforcement. A blow-out center shall protect pump casing from hydraulic shock or excessive pressure. Removal or installation of the check valve must be accomplished through the cover plate opening, without disturbing the suction piping. Sole function of check valve shall be to save energy by eliminating need to reprime after each pumping cycle. Pumps requiring a suction check valve to assist reprime will not be acceptable.
- 6. Spool flanges shall be one-piece cast iron, class 30 fitted to suction and/or discharge ports. Each spool shall have one 1-1/4" NPT and one 1/4" NPT tapped hole with pipe plugs for mounting gauges or other equipment.
- L. Serviceability: No special tools shall be required for replacement of any components within the pump.
- M. Drive Unit: Pump motors shall be horizontal ODP, 1800 RPM, NEMA design B with cast iron frame with copper windings, induction type, with normal starting torque and low starting current characteristics, suitable for continuous service. The motors shall not overload at the design condition or at any head in the operating range as specified.
- N. Drive Transmission:
  - 1. Power to pumps transmitted V-belt drive assemblies. The sheave/belt combination shall provide the speed ratio needed to achieve the specified pump operating conditions.

2. Each drive assembly shall utilize at least two V-belts providing minimum a combined safety factor of 1.5. Single belt drives or systems with a safety factor of less than 1.5 are not acceptable. Computation of safety factors shall be based on performance data published by the drive manufacturer.
3. The pump manufacturer shall submit power transmission calculations which document the following:
  - a. Ratio of pump/motor speed.
  - b. Pitch diameter of driver and driven sheaves.
  - c. Number of belts required per drive.
  - d. Theoretical horsepower transmitted per belt, based on vendor's data.
  - e. Center distance between pump and motor shafts.
  - f. Arc-length correction factor applied to theoretical horsepower transmitted.
  - g. Service factor applied to established design horsepower.
  - h. Safety factor ratio of power transmitted/brake horsepower required.
4. Belt guards:
  - a. Pump drives to be enclosed on all sides by a guard constructed of fabricated steel or combination of materials including expanded, perforated, or solid sheet metal. No opening to a rotating member shall exceed 1/2 inch.
  - b. Guards must be completely removal without interference from any unit component and shall be securely fastened and braced to the unit base.
  - c. Metal to be free from burrs and sharp edges. Structural joints shall be continuously welded. Rivet spacing on panels shall not exceed five inches. Tack welds shall not exceed four inch spacing.
  - d. The guard shall be finished with one coat of gray W.R. non-lift primer and one coat of orange acrylic alkyd W.R. enamel in accordance with section 3, Color Definitions of ANSI Z535.1: Safety Color Code for Marking Physical Hazards.
- O. Pumps, piping, and exposed steel framework shall be cleaned prior to painting. Exposed surfaces to be coated with one coat gray W.R. non-lift primer and one coat white acrylic alkyd W.R. enamel. Paint shall be low VOC, alkyd based, high solids, semi-gloss white enamel for optimum illumination enhancement, incorporating rust inhibitive additives. The finish coat shall be 1.0 to 1.2 MIL dry film thickness (minimum), resistant to oil mist exposure, solvent contact, and salt spray. The factory finish shall allow for over-coating and touch up after final installation.
- P. Station Accessories:

Drain Kit: - Pumps to be supplied with a drain kit for ease of maintenance. The kit shall contain 10' length of reinforced plastic hose with a female quick connect fitting at one end, and factory installed drain fittings in each pump. Fittings include a stainless-steel pipe nipple, stainless steel bushing, stainless steel gate valve and aluminum male quick connect fitting.

Spare Parts Kit: The following minimum spare parts shall be furnished with the pump station:

- a) One pump mechanical seal
- b) Required cover plate O-Ring(s)
- c) One rotating assembly O-Ring
- d) One set of impeller clearance adjustment shims (if required)

Gauge Kit: A gauge kit shall be supplied for each pump. Suction pressure must be monitored by a glycerin-filled compound gauge, and discharge pressure by a glycerin-filled pressure gauge. Gauges to be at least 4 inches in diameter, graduated in feet water column. Rated accuracy shall be 1% of full-scale reading. Compound gauge shall be graduated -34 to +34 feet water column minimum. Pressure gauge to be graduated 0 to 140 feet water column minimum. Gauges to be factory mounted on a resilient panel with frame assembly secured to pumps or piping. Gauge installations shall be complete with all hoses and stainless-steel fittings, including a shutoff valve for each gauge line at the point of connection to suction and discharge pipes.

- Q. Installation: Contractor shall off-load equipment at installation site using equipment of sufficient size and design to prevent injury or damage. Station manufacturer shall provide written instruction for proper handling. Immediately after off-loading, contractor shall inspect complete pump station and appurtenances for shipping damage or missing parts. Any damage or discrepancy shall be noted in written claim with shipper prior to accepting delivery. Validate all station serial numbers and parts lists with shipping documentation. Notify the manufacturer's representative of any unacceptable conditions noted with shipper.

Install, level, align, and lubricate pump station as indicated on project drawings. Installation must be in accordance with written instructions supplied by the manufacturer at time of delivery. Suction pipe connections are vacuum tight. Fasteners at all pipe connections must be tight. Install pipe with supports and thrust blocks to prevent strain and vibration on pump station piping. Install and secure all service lines (level control, air release valve or pump drain lines) as required in wet well. Check motor and control data plates for compatibility to site voltage. Install and test the station ground prior to connecting line voltage to station control panel. Prior to applying electrical power to any motors or control equipment, check all wiring for tight connection. Verify that protective devices (fuses and circuit breakers) conform to project design documents. Manually operate circuit breakers and switches to ensure operation without binding. Open all circuit breakers and disconnects before connecting utility power. Verify line voltage, phase sequence and ground before actual start-up. After all anchor bolts, piping and control connections are installed, completely fill the grout dam in the pump station base with non-shrink grout.

- R. Operational Test: Prior to acceptance by owner, an operational test of all pumps, drives, and control systems shall be conducted to determine if the installed equipment meets the purpose and intent of the specifications. Tests shall demonstrate that all equipment is electrically, mechanically, structurally, and otherwise acceptable; it is safe and in optimum working condition; and conforms to the specified operating characteristics.

After construction debris and foreign material has been removed from the wet well, contractor shall supply clear water volume adequate to operate station through several pumping cycles. Observe and record operation of pumps, suction and discharge gage readings, ampere draw, pump controls, and liquid level controls. Check calibration of all instrumentation equipment, test manual control devices, and automatic control systems. Be alert to any undue noise, vibration or other operational problems.

## 2.15 SELF PRIMING PUMPS PIPING AND VALVES:

- A. Each pump shall be equipped with a full flow type check valve, capable of passing a 3" spherical solid, with flanged ends and be fitted with an external lever and spring. The valve seat shall be constructed of stainless steel and shall be replaceable. The valve body shall be cast iron and incorporate a 3" cleanout port. Valve clapper shall have a molded neoprene seating surface incorporating low pressure sealing rings. Valve hinge pin and internal hinge arm shall be stainless steel supported on each end in brass bushings, sealing bushing shall have double O-rings. O-rings shall be easily replaceable without requiring access to interior of valve body. Valve shall be rated at 175 PSI water working pressure, 350 PSI hydrostatic test pressure. Valves other than full flow type or valves mounted in such a manner that prevents the passage of a 3" spherical solid shall not be acceptable.
- B. A 3-way plug valve must allow either or both pumps to be isolated from the force main. Valve shall pass 3" spherical solids. The plug valve shall be non-lubricated, tapered type. Valve body shall be semi-steel with flanged end connections drilled to 125-pound standard. The drip-tight shutoff plug shall be mounted in stainless steel bearings and shall have a resilient facing bonded to the sealing surface. Valve shall be operated with a single lever actuator providing lift, turn, and reseat action. The lever shall have a locking device to hold the plug in the desired position.
- C. Automatic Air Release Valves: An automatic air release valve shall be furnished for each pump designed to permit the escape of air to the atmosphere during initial priming or unattended repriming cycles. Upon completion of the priming cycle or repriming cycle, the valve shall close to prevent recirculation. Valves shall provide visual indication of valve closure and shall operate solely on discharge pressure. Valves which require connection to the suction line shall not be acceptable.

All valve parts exposed to sewage shall be constructed of cast iron, stainless steel, or similar corrosion resistant materials. Diaphragms, if used, shall be of fabric reinforced neoprene or similar inert material.

A cleanout port, three inches in diameter, shall be provided for ease of inspection, cleanout, and service. Valves shall be field adjustable for varying discharge heads. Connection of the air release valves to the station piping shall include stainless steel fittings.

- D. Piping: Flanged header pipe shall be centrifugally cast, ductile iron, complying with ANSI/AWWA A21.51/C115 and minimum class 52 thickness. Flanges shall be cast iron class 125 and comply with ANSI B16.1. Pipe and flanges shall be threaded, and suitable thread sealant applied before assembling flange to pipe.



Bolt holes shall be in angular alignment within 1/2 degrees between flanges. Flanges shall be faced with a gasket finish having concentric grooves a minimum of 0.01-inch-deep by approximately 0.03 inch wide, with a minimum of three grooves on any given surface spaced a maximum of 1/4 inch apart.

- E. Supports and Thrust Blocks: Contractor must ensure all pipes connected to the pump station are supported to prevent piping loads from being transmitted to pumps or station piping. Pump station discharge force main piping shall be anchored with thrust blocks where shown on the contract drawings.

## 2.16 SELF-PRIMING PUMPS ELECTRICAL:

- A. The pump station control panel will be tested as an integral unit by the pump station manufacturer. The control panel shall also be tested with the pump station as a complete working system at the pump station manufacturer's facility.
- B. Panel Enclosure:
  - 1. Electrical control equipment shall be mounted within a NEMA 1 stainless steel, dead front type, control enclosure. Door shall be hinged and sealed with a neoprene gasket and equipped with captive closing hardware. Control components shall be mounted on a removable steel back panel secured to enclosure with collar studs.
  - 2. All control devices and instruments shall be mounted using threaded fasteners and shall be clearly labeled to indicate function.
- C. Branch Components:
  - 1. Motor branch components to be of highest industrial quality, secured to the sub-plate with machine screws and lock washers. Mounting holes shall be drilled and tapped; self-tapping screws shall not be used to mount any component.
  - 2. Circuit Breakers and Operating Mechanisms:
    - a. A properly sized heavy-duty circuit breaker, with RMS interrupting rating for adequate amperes at design volts, shall be furnished for each pump motor. The circuit breakers must be sealed by the manufacturer after calibration to prevent tampering.
    - b. An operating mechanism installed on each motor circuit breaker shall penetrate the control panel door. A pad lockable operator handle shall be secured on the exterior surface. Interlocks must prevent opening the door until circuit breakers are in "OFF" position.
  - 3. An open frame, across-the-line, NEMA rated magnetic starter with under-voltage release, and overload protection on all three phases, shall be furnished for each pump motor. Starters of NEMA size 1 and above shall allow addition of at least two auxiliary contacts. Starters rated "0", "00", or fractional size are not acceptable. Power contacts to be double-break type made of cadmium oxide silver. Coils to be epoxy molded for protection from moisture and corrosive atmospheres. Contacts and coils shall be easily

replaceable without removing the starter from its mounted position. Each starter shall have a metal mounting plate for durability.

4. Overload relays shall be solid-state block type, having visual trip indication with trip-free operation. Electrically resetting the overload will cause one (1) normally open and one (1) normally closed isolated alarm/control contact to reset, thus re-establishing a control circuit. Trip setting shall be governed by solid-state circuitry and adjustable current setting. Trip classes shall be 10, 15 and 20. Additional features to include phase loss protection, selectable jam/stall protection and selectable ground fault protection.
5. An overload reset pushbutton, mounted through the control panel door, shall permit resetting the overload relays without opening the control panel door.

D. Control Circuit:

1. A normal duty thermal-magnetic circuit breaker shall protect all control circuits by interrupting control power.
2. Pump mode selector switches shall permit manual start or stop of each pump individually or permit automatic operation under control of the liquid level control system. Manual operation shall override all shutdown systems, except the motor overload relays. Selector switches to be heavy duty, oil-tight design with contacts rated NEMA A300 minimum.
3. Pump alternator relay to be electro-mechanical industrial design. Relay contacts to be rated 10 amperes minimum at 120 volts non-inductive. A switch shall permit the station operator to select automatic alternation of pumps, to select pump number one to be "lead" for each pumping cycle, or to select pump number two to be "lead" pump for each pumping cycle.
4. Six-digit elapsed time meter (non-reset type) shall be connected to each motor starter to indicate total running time of each pump in "hours" and "tenths of hours". An integral pilot light shall be wired in parallel to indicate that the motor is energized and should be running.
5. A high pump temperature protection circuit shall override the level control and shut down the pump motor(s) when required to protect the pump from excessive temperature. A thermostat shall be mounted on each pump casing and connected to a high pump temperature shutdown circuit. If casing temperature rises to a level sufficient to cause damage, the thermostat causes the pump shutdown circuit to interrupt power to the motor. A visible indicator located on the control panel door shall indicate motor stopped due to high pump temperature. The motor shall remain locked out until the pump has cooled and circuit has been manually reset. Automatic reset of this circuit is not acceptable.
6. A duplex ground fault receptacle providing 115 VAC, 60 Hz, single phase current, will be mounted on the side of the control enclosure. Receptacle circuit shall be protected by a 15-ampere thermal-magnetic circuit breaker.

7. Wiring:

- a. The pump station, as furnished by the manufacturer, shall be completely wired, except for power feed lines to the branch circuit breakers and final connections to remote alarm devices.
- b. All wiring, workmanship, and schematic wiring diagrams shall comply with applicable standards and specifications of the National Electric Code (NEC).
- c. All user serviceable wiring shall be type MTW or THW, 600 volts, color coded as follows:
  - 1) Line and Load Circuits, AC or DC power ..... Black
  - 2) AC Control Circuit Less Than Line Voltage..... Red
  - 3) DC Control Circuit.....Blue
  - 4) Interlock Control Circuit from external source ..... Yellow
  - 5) Equipment Grounding Conductor..... Green
  - 6) Current Carrying Ground .....White
  - 7) Hot with Circuit Breaker Open..... Orange
- d. Control circuit wiring inside the panel, with exception of internal wiring of individual components, shall be 16 gauge minimum, type MTW or THW, 600 volts. Power wiring to be 14 gauge minimum. Motor branch wiring shall be 10 gauge minimum.
- e. Motor branch and other power conductors shall not be loaded above 60 degrees C temperature rating, on circuits of 100 amperes or less, nor above 75 degrees C on circuits over 100 amperes. Wires must be clearly numbered at each end in conformance with applicable standards. All wire connectors in the control panel shall be ring tongue type with nylon insulated shanks. All wires on the sub-plate shall be bundled and tied. All wires extending from components mounted on door shall terminate at a terminal block mounted on the back panel. All wiring outside the panel shall be routed through conduit.
- f. Control wires connected to door mounted components must be tied and bundled in accordance with good commercial practice. Bundles shall be made flexible at the hinged side of the enclosure. Adequate length and flex shall allow the door to swing full open without undue stress or abrasion. Bundles shall be held on each side of hinge by mechanical fastening devices.

8. Conduit:

- a. Factory installed conduit shall conform to following requirements:
  - 1) All conduit and fittings to be UL listed.
  - 2) Liquid tight flexible metal conduit to be constructed of smooth, flexible galvanized steel core with smooth abrasion resistant, liquid tight polyvinyl chloride cover.

- 3) Conduit to be supported in accordance with articles 346, 347, and 350 of the National Electric Code.
- 4) Conduit shall be sized according to the National Electric Code.

9. Grounding:

- a. Station manufacturer shall ground all electrical equipment inside the pump station to the control panel back plate. All paint must be removed from the grounding mounting surface before making final connection.
- b. The contractor shall provide an earth driven ground connection to the pump station at the main grounding lug in accordance with the National Electric Code (NEC).

10. Equipment Marking:

- a. Permanent corrosion resistant name plate(s) shall be attached to the control and include following information:
  - 1) Equipment serial number
  - 2) Supply voltage, phase and frequency
  - 3) Current rating of the minimum main conductor
  - 4) Electrical wiring diagram number
  - 5) Motor horsepower and full load current
  - 6) Motor overload heater element
  - 7) Motor circuit breaker trip current rating
  - 8) Name and location of equipment manufacturer
- b. Control components shall be permanently marked using the same identification keys shown on the electrical diagram. Labels shall be mounted adjacent to device being identified.
- c. Switches, indicators, and instruments mounted through the control panel door shall be labeled to indicate function, position, etc. Labels shall be mounted adjacent to, or above the device.

E. Liquid Level Control: This specification is intended to cover a complete and operational automatic pump and alarm control system that responds to the wet well level excursions. It is the specific intention of this functional requirement that a standard controller will be employed with features as herein described and that it be a fully integrated assembly.

Pump controller shall be a MPE 1000 Lift Station Controller or approved equivalent. Including a minimum of the following specifications:

The Controller shall control up to three pumps to perform liquid level control. The Controller shall be capable of alternating the pumps and shall provide lag pump delays and high- and low-level alarms and shall perform both pump-down and pump-up operation.

The Controller shall be standard “off the shelf” equipment with published literature and fully tested hardware and operating program. The Controller must be field configurable from the front of the unit and require no special tools or software to set-up or operate.

The Controller shall be UL listed as Industrial Control Equipment, UL 508.

The Controller shall accept an input signal in the following forms: a 4-20 mA analog signal, inputs from a Conductance Level Probe, or Float Switches.

All connections to the Controller shall be made to be removable, “Phoenix” style combination connector/plugs.

The Controller shall be a microcontroller-based device and not require a battery to maintain the operating program. All set-up values shall be stored in non-volatile memory.

A numerical level display shall be provided on the front of the unit. It shall have a 3-digit, 7 segment LED display and show levels in feet and tenths of feet. All setup parameter values shall be viewed or changed from the front of the Controller.

The Controller shall not require an external power supply or any external I/O modules to be a fully functioning unit. An analog input (4-20mA) with zero and span adjustments shall be provided for the scaling of the wet-well level input.

The Controller shall have 12 discrete inputs. Inputs shall be transient protected and be programmable for the following functions:

- Pump disable with HOA in OFF, or pump fault
- Freeze wet well level during a bubbler tube purge
- External Alternator Selector Switch
- Limit number of pumps called to run on emergency power
- All Pump Disable – for connection to Phase Monitor
- Sequence Input for Lead Lag Select Switches
- High- and Low-Level Alarms
- Pump disable upon low level – for connection to low level float switch
- Float switch backup
- Low Level Pump Cutoff
- Start Flush Cycle
- Inputs for user selectable SCADA functions

The status of all the discrete inputs shall also be viewable from the front of the unit.

All electrical connections, for power or I/O, shall be by quick disconnect Phoenix style connectors.

The Controller shall have a connector for a conductance level probe of ten sensor points.

Relay outputs shall be provided as standard for high- and low-level alarms and for the control of up to three pumps.

If not being used, the ten conductance level probe inputs shall be available for

use as ten additional discrete SCADA inputs, or for control via float switches.

The Controller shall remember which pump was in the lead position during a power outage.

The Controller shall include a fault indicator on the front of the unit and retrievable fault codes to aid in troubleshooting.

A level simulation feature shall also be available from the front of the unit. The Controller shall automatically return to monitoring wet well level after sixty seconds, if left in simulation mode.

An RS232 serial port with the Modbus RTU protocol shall be provided for SCADA. Programming shall be in place to collect and transmit the station status, and to allow for the remote control of the pumps.

The Controller shall provide an RS232 Serial Port as a standard feature and shall have an Ethernet port available as an option.

The Pump On/Off levels, high level alarm, and low-level alarm setup values shall be viewable and changeable from a remote location.

Pump elapsed time meters shall be viewable and resettable remotely and shall be stored in non-volatile memory during a power outage.

The Controller shall be able to perform float back-up using from two to six floats. The Controller shall have adjustable lag pump(s) delay.

The Controller shall have a parameter setting to select the number of pumps to control.

The Controller shall have a parameter setting to select the number of pumps to run at one time.

The Controller shall have a parameter setting to select the number of pumps allowed to run while on generator power.

Menu selectable alternation modes shall include:

Standard Alternation

Jockey Pump (Pump 1 stays on when other pumps turn on)

Jockey Pump (Pump 1 turns off when other pumps turn on)

Split alternation (Pumps 1 & 2, Pump 3)

Fixed sequence (Pump 1 always lead)

Stepped on/off (Only one pump runs at a time)

Menu selectable First-On/First-Off or First-On/Last-Off alternation sequences shall be available.

The Controller shall contain a parameter setting to allow the disabling of the automatic alternation.

The Controller shall contain a parameter to allow the Controller to be used in either a Pump Up or a Pump Down configuration.

The Controller shall have parameters for calibrating the zero and span of the

level input signal.

The Controller shall contain a parameter for setting the slave address of the Controller when used in a SCADA application.

The Controller shall contain parameter registers for the setup of the RS232 port.

The Controller shall contain a parameter to limit malicious attempts to control the pumps remotely or to change the setup parameters.

The Controller shall be able to force lead pump position by parameter selection.

The Controller shall be able to perform an automatic flush cycle to reduce sludge build up within the wet well.

The Controller shall have a wet well flush cycle that is able to be remotely controlled via SCADA.

The Controller shall contain a flow calculator that provides the following:

Latest Inflow Rate

Average Daily Flow (Average of the last 7 days)

Pump Outflow Rate (Latest Rate for each pump)

The Controller shall have a parameter selection to select time for time-based forced alternation.

The Controller shall contain pump disable discrete inputs shall cause the alternation routine to skip over disabled pumps. These pumps disable discrete inputs shall be able to be inverted by a parameter setting.

The Controller shall contain registers for quick verification of the firmware revision level.

The Controller shall have a fault code register to aid in troubleshooting.

The Controller shall also have parameters to allow level probe to be a back-up to the analog transducer input.

The Controller shall have parameter-based setup for the 12 discrete inputs.

The Controller shall contain a discrete input for connection to an external time clock to force pump alternation.

The Controller shall have a parameter setting to allow the analog input level to be a 4-20mA signal from a transducer, a conductance level probe, or a remote level input signal from SCADA.

The Controller shall have a parameter to select the level probe type by the selection of the distance between the electrodes.

The Controller shall have a level offset parameter to enable the transducer or conductance level probe to be placed off the bottom of the wet well, while maintaining an accurate representation of the wet well depth.

The Controller shall have a choice of sensitivity settings for use with a

conductance probe.

The Controller's unused output relays shall be able to be programmed through SCADA for additional control uses.

The Controller shall contain parameters to view the status of the Level Probe electrodes.

The Controller shall monitor the square wave signal at the Level Probe inputs and shall create a fault code if an improper square wave is detected.

The Controller shall contain the ability to perform the following SCADA features

**Monitor the status of:**

Wet well Level  
All Discrete Inputs  
Pump On, Pump Off, High and Low Alarm Levels  
Individual Pump Disable Status  
All Pump Disable Status  
Float Backup Status  
On Generator Status  
Level Probe Backup Status  
Pump Forced On Status  
ETMs  
Relay Remote Control Status  
Forced Alternation Status  
Pump Run Status  
Current Lead Pump Status  
Level Probe Electrode Status  
Fault Code Status  
Last Fault Code Status  
Internal 5V Power Supply Status  
Internal 24V Power Supply Status  
Controller Program Revision Number  
Flush Cycle Operation  
Flow Calculator, Latest Inflow Rate  
Flow Calculator, Average Daily Flow  
Flow Calculator, Outflow Rate per Pump  
Flow Calculator, Daily Inflow Total for last 7 days

**Control:**

Remotely Change Pump On, Pump Off, High and Low Alarm Levels  
Remotely Reset ETM's  
Remotely Force Pumps On  
Remotely Disable Pumps  
Remotely Force Alternation  
Remotely Select Lead Pump  
Remotely Reset Fault Code Register  
Remotely Reset Last Fault Code Register  
Remotely Control Unused Relays  
Remotely Start Wet Well Flush Cycle  
Remotely Stop Wet Well Flush Cycle



**Fault Codes:**

The following Fault Codes shall be available for Controller Troubleshooting  
**Communication Fault**

Parameter Setup Faults  
Normal Operation Disabled  
Pump Operation on Float Backup  
Backup Float Out-of-Sequence  
All Pump Disable  
Level Probe Fault  
Level Probe Out-of-Sequence  
Pumps called to run by Level Probe Back-Up  
Flow Calculator Setup Fault

The Controller shall offer the following optional features:

4-20mA Analog Level input may be ordered as an isolated input

F. Level Sensor:

1. The liquid level of the wet well shall be sensed by a VEGAPULS C21 or preapproved equivalent.
2. The sensor assembly shall be installed and connected with other system elements and placed in successful operation. It shall be provided with input power and output signal transient protection, associated control elements as specified herein and in accordance with manufacturer's instructions.
3. The sensor shall be suspension-mounted using manufacturer's recommended mounting hardware. All hardware, bolts, nuts, and screws shall be Stainless Steel.

G. Secondary Lightning Arrestor: The control panel shall be equipped with a secondary lightning arrestor to minimize damage to the pump motors and control from transient voltage surges. The arrestor shall utilize silicon-oxide varistors encapsulated in a non-conductive housing. The arrestor shall have a current rating of 60,000 Amps, and a Joule rating of 1500. Arrestors provided shall be listed on the materials and approved manufacturers.

H. Phase Monitor: The control panel shall be equipped to monitor the incoming power and shut down the pump motors when required to protect the motor(s) from damage caused by phase reversal, phase loss, low voltage, and voltage unbalance. An integral time delay shall be provided to minimize nuisance trips. The motor(s) shall automatically restart when power conditions return to normal. Phase monitors shall be listed on the materials and approved manufacturers.

2.17 SUBMERSIBLE PUMPS:

A. Where design conditions allow for submersible pumps, this type of pump shall be installed. All submersible pumps of the same type, frame and size shall be of the same manufacturer and shall have interchangeable parts and shall be a type and brand listed as approved by the City of Fairhope, Alabama. All screws, small bolts, nuts, washers and miscellaneous items normally subjected to corrosion shall be constructed of Everdur, Monel, bronze, or stainless-steel exceeding 12% chrome and 7% nickel. All completed and installed operating pump units and accessories shall be suitable for the intended location and service shall be

free of operating problems, unusual vibrations and noise throughout the entire operating range of the equipment. Undesirable operation, vibration, or noise in a pump unit or accessories shall be corrected, and if necessary, the entire unit shall be replaced at no additional cost to the Owner.

- B. General: Motors shall be rated as to full load horsepower values shown on the plans (see Appendices) and shall have electrical characteristics corresponding to the electrical power system at the installation. The motor shall be designed for continuous as well as intermittent operation and shall be non-overloading over the entire operational range of the pump.

Thermal sensors shall be used to monitor stator temperatures. The stator shall be equipped with three thermal switches, embedded in the end coils of the stator winding (one switch in each stator phase).

The motor shall have bearings designed for a minimum B-10 life of 15,000 hours and shall be equipped with moisture sensors located between two mechanical seals in an oil filled seal chamber for external seal failure alarm.

The motor shall be labeled by Underwriters Laboratory, Inc. or Factory Mutual as approved for use in Class I, Division I, Group D hazardous locations and rated as suitable for submergence in raw sewage.

Unless otherwise specifically noted, not less than 30 feet of heavy-duty grease resistant submersible multi-conductor electrical power and pilot cable with grounding conductor shall be provided connected to the motor ready for operation.

Provide not less than four copies of technical information and parts listing, including recommended maintenance, describing pumps and motors including pump performance curve, minimum submersion head for pumps and range of available impeller sizes and their power requirements.

Provide written guarantee for replacement of pump and motor for failure of satisfactory performance and for defective parts of assembly.

Pumps provided for variable speed duty shall, in addition to requirements specified herein and elsewhere, be provided with the following written documentation by the pump manufacturer.

1. The pumps furnished shall be suitable for the variable speed duty at the conditions encountered at the installation location.
2. Equal pumping units shall have been in satisfactory variable speed service for a minimum of one year.

- C. Pump Installation: Pumps shall be installed in accordance with the manufacturer's recommendations and as approved. Where guide bars are indicated, pumps shall be mounted on guide bars as shown on the plans. Coat bolt thread projections with lubricant to facilitate future nut removal.

- D. The Contractor shall provide in a suitable substantial case any special tools or adjustment devices necessary for the proper maintenance and adjustment of the equipment furnished. This shall include all special or unusual items necessary for the dismantling and assembling of all furnished equipment.

- E. Four instruction manuals, clean and unused, shall be delivered to the Owner for the pumps, motors, and all accessories. Each instruction manual shall carry the serial number of the piece of equipment to which it applies, design data, operating instructions, lubricating instructions, maintenance instructions, assembly drawings showing location of parts and test curve. Each instruction manual shall be bound in a stiff black folder with the name of the pumping station and the unit numbers or name embossed on the outside.
- F. The Contractor shall furnish and install all necessary break-in lubricants and all final lubricants as recommended by the manufacturer for all pumps, motors and accessories.
- G. Supplier's/Manufacturer's Services: The Contractor shall furnish the services of qualified technical personnel representing the manufacturer or group of manufacturers for each equipment grouping or system within the project, for checking the installation, making the necessary adjustments, placing the equipment in operation, and during acceptance tests. The representatives shall be available and scheduled with the Owner to instruct operating personnel in the use, operation, and maintenance of the equipment during the initial on-line operating period. All components and equipment shall be installed in accordance with the recommendations of the manufacturer.

Operating tests shall be performed by the manufacturer's representative on all equipment in the presence of the Owner and the Engineer or their representatives in order to demonstrate the entire facility to be complete, functional, and ready to be placed in operation.

Operating instructions shall be given to the Owner's regular operating personnel by the equipment manufacturer's representative where complex equipment is provided and by the Contractor for other equipment in order to thoroughly familiarize the operators in the correct procedures and functions for operating and maintaining the facility.

- H. Pump Identification Plate: A 16-gauge stainless steel identification plate shall be securely mounted on each pump in a readily visible location. The plate shall bear the 1/4-inch die-stamped equipment identification number that is assigned each pump in the Pump Specification Sheets.
- I. Lifting Lugs: Equipment weighing over 100 pounds shall be provided with lifting lugs.
- J. Performance Tests: The Contractor shall perform field tests on all completed pump and control system assemblies, as required by the Pump Specification Sheets, to demonstrate their conformance to the specifications to the satisfaction of the Engineer. A test log shall be presented to the Engineer upon the completion of each test that records the following:
  - 1. Flow, in gallons per minute.
  - 2. Pump discharge pressures as measured by calibrated gauges, converted to feet of the liquid pumped and corrected to pump datum as defined by Hydraulic Institute Standards, calculated velocity heads at the discharge flanges, and total head, all tabulated in feet.
  - 3. Applied voltage and amperage measured for each phase.

4. Complete nameplate data.

Factory Tests:

5. Pumps: A factory test certified by the pump manufacturer's test representative shall be performed on all pumps furnished and written notice of the same shall be furnished to the Engineer. Information required to be furnished at the time of test is as necessary to show conformance to specified performance. Tests shall conform to the Hydraulic Institute Standards test code.
  6. Motor Tests and Test Reports: As specified in Pump Specification Sheets, pump drivers shall not be overloaded within a 1.0 service factor rating at any point on the pump curve.
  7. Balance of Vibration: The rotating parts of each pump and its driving unit shall be dynamically balanced before final assembly. The driving unit alone shall operate without vibration in excess of the limits stated in the latest revision of NEMA MG 1.
- K. Functional Test: Prior to plant startup or field performance test, all equipment described in the Pump Specification Sheets following shall be inspected for proper alignment, quiet operation, proper connection, and satisfactory performance by means of a functional test.
- L. Spare Parts for pumps shall be furnished to provide 12 months of full-time service and special tools required for that service shall be suitably boxed and marked for shipment and storage.

NOTE: See attached Pump Specification Sheets for pump system and performance warranty requirements. All pumps shall be on the City's list of materials and approved manufacturers.

2.18 SUMBERSIBLE PUMP VALVES AND PIPING:

Valves and piping shall be located as shown on the drawings. Gate valves, check valves, and flanged ductile iron piping shall be in accordance with the City's accepted materials.

2.19 SUBMERSIBLE PUMPS ELECTRICAL:

- A. All electrical material and equipment provided by the Contractor shall be new and free of defects. All work performed under this section of the specifications shall be carried out by skilled workers regularly engaged in the performance of such duties. The entire electrical installation shall be not less than that required by the latest edition of the National Electrical Code, the Occupational Safety and Health Act, and all electrical codes locally enforced in the project area. The Contractor shall obtain all permits required by local ordinances and after completion of the work, shall give the Engineer a certificate of final inspection and approval from the local Electrical Inspection Office. Any expenses connected with such inspection and certificate shall be borne by the Contractor.

Electrical material and equipment shall be designed in accordance with the latest requirements of applicable standards such as NEMA, ANSI, IEEE, and where listings are available for such items, shall be approved by the Underwriters Laboratories, Inc. Equipment, components, material, etc., rated by other standards and agencies including but not limited to IEC, VDE, and DIN will not be considered equal to NEMA, ANSI, IEEE, and UL. Electrical items shall be standard cataloged products of manufacturers regularly engaged in the manufacture of such products, unless otherwise noted.

B. Grounding:

1. Non-current carrying metal parts of electrical items such as cabinets, enclosures, frames, etc., and the neutral conductor shall be grounded in accordance with the National Electrical Code unless additional grounding requirements are indicated. Grounding conductors shall be copper, sized as noted. Special grounding system features shall be provided as indicated.
2. All conduit runs installed for lighting and power loads shall contain a grounding conductor throughout the entire length of the run forming a part of the grounding system. The grounding system shall be electrically continuous throughout the electrical system and shall be connected to earth ground at the point of power service and as otherwise indicated.
3. Ground rods shall be copper welded steel type, 3/4-inch diameter, 20'-0" length, minimum. Ground rods shall be driven to 1'-0" (minimum) below finished grade unless otherwise indicated and shall be electrically connected with suitable cast type ground clamps or exothermic welding.
4. Resistance to ground of each ground rod shall not exceed 5 ohms when measured during dry weather. In the event this value is not obtained, one additional rod or rod section equal to that tested shall be driven. Should the additional rod or section fail to achieve the required value, the Engineer shall be immediately notified. A written record of all resistance measurements and test dates shall be submitted to the Engineer prior to completion of the project.

C. Lightning and Surge Protection:

1. Lightning protector units shall be provided for power circuit protection at the main service connection point and elsewhere as noted on the plans. Lightning protectors provided shall be listed on the materials and approved manufacturers for three- and single-phase circuits, respectively.

D. Insulation Tests:

1. Circuit insulation tests shall be performed to prove each circuit free of faults after all wiring is completed prior to equipment and fixture connections, and again after the installation is complete and ready for use.
2. Tests shall be made at the main electrical service connection between all conductors and between line conductors and ground. Tests shall be made with a 1,000 Vdc instrument capable of accurately measuring the resistance involved. Readings shall be taken in the presence of the

Engineer or his representative for each test and the written results of each test shall be submitted to the Engineer.

E. Conductors:

1. Single conductors installed in raceways shall be copper with AWG sizes as noted and shall have 600 volts rated, type THW/THHN/THWN or XHHW, 75°C (minimum) insulation. Conductors requiring special consideration shall have insulation material and ratings noted on the plans and as required by the National Electrical Code. Type TW insulation shall not be used for any purpose in this contract except ground wire identification only.
2. Lighting and power conductors shall be minimum size No. 12 AWG, with AWG No. 8 and larger to be stranded, and AWG No. 10 and smaller to be solid unless otherwise noted. Conductors shall be stranded where movement, vibration, or other flexing occurs in order to prevent conductor fatigue. Control conductors may be AWG No. 14 stranded, unless otherwise noted.
3. Insulation colors shall be green for ground; white for neutral; and black for single phase line conductor. "Stinger" phase conductor of 120/240 V systems shall be orange as per NEC 215.8. Unless otherwise noted, a uniform insulation color scheme for all new three phase systems shall be established as black for phase A, red for phase B, and blue for phase C. Control circuit insulation shall be yellow. Conductors size AWG 10 and larger may be black with entire exposed ends taped with "Scotch #35" or equal by Plymouth, in accordance with color schemes mentioned herein.
4. Direct buried grounding system conductors shall be bare copper, sized as noted.

F. Splices and Terminations:

1. 600-volt system conductors shall be spliced with "Ideal Wire-Nuts" or equal by T & B for AWG No. 10 and smaller for dry areas and machine crimped or bolted connectors with "Scotch 88" or equal by Plymouth, full coverage tape for all other splices. Soldered and taped splices will not be acceptable. Terminations shall be made with mechanical lugs or other acceptable termination features of the equipment supplied.
2. Control conductors shall terminate on box clamp, binding post screw, or set screws only. Soldered, taped and free-standing connections will not be acceptable.

G. Conduit:

1. Steel conduit shall be provided unless otherwise indicated and shall be heavy-wall, rigid galvanized type bearing the Underwriters Laboratories, Inc. label of approval. Conduit minimum size shall be 1/2 inch. Fittings for rigid steel conduit shall be threaded types made up with conductive waterproof compound. Seal-off fittings shall be provided as required by the National Electrical Code.

2. All conduit shall be clean and free from dents, scars, or other deformities. Connections shall be made watertight and bushings shall be provided where smooth hubs are not encountered. Changes in directions shall be made with symmetrical bends or conduit boxes. Field made bends shall be made with an approved hickey or conduit bending apparatus. Conduit runs shall be installed parallel or perpendicular to structural members. Conduit hangers and supports shall be provided at intervals recommended by the manufacturer and the National Electrical Code. Underground conduit runs shall be installed at least 1'-6" below finished grade unless other depths are indicated. Plain earth used for backfilling shall be free from objectionable material such as rocks, glass, metal, wood, etc. and shall be tamped to surrounding earth density.

H. Cable Connectors and Supports:

1. Conduit runs into the wet well for cable protection shall be positioned to suit field conditions to achieve an unobstructed passage for removal and installation of pumping units and shall provide close accessibility to allow removal of the cable connector by maintenance personnel from outside and above the wet well.
2. Cables entering conduit protection and as otherwise notified shall be fitted with connectors sized to suit the cable and conduit installed. Connectors shall be plastic body and threaded cap type with neoprene or equal internal gas-tight compression gland. Connectors shall be CGB type manufactured by Thomas & Betts, Hubbell or Daniel.
3. Cable grips shall be provided as strain relief for cables and shall be wire mesh offset eye, closed mesh type, all fabricated with 304 stainless steel and shall be sized to suit the cable installed. Cable grips shall be Kellems 024-01-XXX series or equal by Daniel Woodhead.

I. Receptacles:

1. Duplex convenience receptacles shall be rated 15 amps, 125 volts, two pole, three wire, grounding type, specification grade, GFI configuration unless otherwise noted. Receptacles shall be brown for unfinished areas and ivory for finished walls. Where installed in damp locations, receptacles shall be installed in weatherproof enclosures.
2. Special receptacles shall be provided as noted and shall have electrical ratings, pole configuration, and number of poles as shown or required. Enclosures, receptacle types, and other special features shall be suitable for the duty and conditions encountered.

J. Switches:

1. Safety switches shall be provided where indicated and elsewhere as required by the National Electrical Code. Safety switches shall be heavy-duty type, with voltage, current, fuses, number of poles, and enclosure types as noted. All switches requiring security including main power service, transfer, and switches installed out-of-doors shall be provided with padlocks as hereinafter specified. NEMA 4X switches shall be installed out-of-doors.

K. Fuses:

1. Unless otherwise noted, fuses provided for motor protection and other general-purpose loads shall be dual-element type, "Buss Fusetron" or equal by Shawmut, with voltage and current ratings as required.
2. Control circuit fuses shall be "Buss FNM" for 120-volt circuits and "Buss KTK" for 480-volt circuits or equal by Shawmut. Unless otherwise noted, control circuit fuses shall be installed in terminal strip mounted switch action fuse blocks rated for 15 amps at 600 volts.

L. Circuit Breakers:

1. Branch and feeder circuit breakers shall be thermal-magnetic, molded case, industrial type, unless otherwise noted, and shall be listed by the Underwriters Laboratories, Inc. for not less than 14,000 amps symmetrical interrupting at 480 volts. Voltage, trip and frame current ratings, and number of poles shall be as indicated or required. Circuit breakers shall have trip-free operating handles with trip current rating permanently molded therein.
2. Circuit breakers provided as an integral part of combination motor starters may be as specified herein or may be magnetic only type manufactured specifically for motor protection duty and set for the actual motor nameplate data.
3. Circuit breakers provided to serve 120-volt lighting, receptacles, and other small loads shall be rated by Underwriters Laboratories, Inc. for not less than 10,000 amps symmetrical interrupting and otherwise shall be as specified herein. Multiple circuit breakers shall be factory assembled and sealed. Tandem type breakers and bailed tied handles of single unit breakers are not acceptable for this work.

M. Motor Starters:

1. Starters shall be sized in whole increment NEMA designation with voltage rating poles and enclosure as noted or otherwise required. Starters shall be Furnace ESP-100. Starters shall be approved by the Underwriters Laboratories; Inc. Ambient temperature compensated overcurrent protection shall be provided in each ungrounded phase of the circuit and shall be sized to suit the motor provided. Auxiliary equipment including contacts, selector switches, pushbuttons, lights, control power transformer, fuses, etc. shall be provided as noted or otherwise required.
2. Starters shall be designed and rated in accordance with NEMA Table 2-321-1. Ratings by IEC, VDE, DIN, etc. will not be considered for this work. Terminal temperature rise rating shall not exceed 50° C. Operating coils and overcurrent sensors shall be readily and independently replaceable in the field without requiring complete starter exchange.
3. Starters indicated as being combination type shall be circuit breaker type motor circuit protector combination type set to suit the motor provided.
4. Starters shall be magnetic type, full voltage, non-reversing, NEMA Size 1 minimum with wiping style contacts, unless otherwise noted.



N. Special Control Panel:

1. Control panel shall be surface mounted NEMA 4X 304 stainless steel Hoffman style A-SSLP type construction. Control components shall be as indicated on the plans. Control panels shall be provided with padlocks as specified hereinafter. Dimensions shall be as shown on the plans. Stainless steel cabinets shall be brushed finished. All drilling and cutting shall be smooth and escutcheon plates or bezel rings shall be provided on all openings.
2. Control components and associated items shall be as shown on the plans and in accordance with other applicable paragraphs of this specification. Component arrangements shall be as shown on the plans. Panel manufacturer shall completely wire the panel using AWG No. 14 (minimum) conductors rated XHHW, 75° C (minimum). Each end of all conductors shall be identified with permanent type markers corresponding to shop drawing wiring diagram submitted for the control panel. All field wiring shall be connected to terminal strip or lugs of starters, contractors, or other larger components. Each conductor within the panel shall be labeled at each end for identification.
3. Shop drawings showing physical dimensions, component placement, and complete coordinated composite control diagrams and elementary diagrams shall be submitted to the Engineer for approval and shall show the individual control components by manufacturer's catalog number and the wire numbers actually connected in the completed installation. Complete coordinated drawings are to include all devices internal and external to the control panel.

2.20 SUBMERSIBLE PUMPS CONTROLS:

A. Control Components:

1. Selector switches, pushbuttons, and indicator lights, unless otherwise noted, shall be round style, heavy-duty, oil-tight type equal to Square D Class 9001, Type K or Cutler-Hammer Type T and shall have nameplate lettering as noted on the plans. Miniature style units will not be acceptable unless otherwise noted on the plans. Operator mechanism including locking ring and legend plate shall be a corrosion resistant material. Operators installed exposed to corrosive atmospheres or wet areas shall be NEMA 4X rated. Switch contacts shall be arranged for the configuration and duty as indicated and operating handles shall be easily operated by hand without the use of tools. Pushbuttons shall be momentary or maintained contact type as indicated. Switches and pushbuttons located remotely from the controller shall be with lockout features. Indicator light lenses shall be glass type with color as noted. Lamp replacement shall require removal of the front mounted lens cap only. Where control unit exhibits corrosion or other physical failure during the contract time frame, the Contractor shall replace the entire item at the expense of the Contractor.

2. Control relays shall be equal to Square D, Type X, 300-volt, fixed mounting type, molded case frame industrial type, with number of poles, contact arrangements, and operating voltages indicated. Contacts shall be convertible type. Relays noted to have time delay actions shall be adjustable type with time delay values as notes. Contacts shall be convertible type and shall be readily replaceable without requiring complete relay exchange. Open style, "Ice Cube" style, and plug-in type relays will not be considered for this work unless specifically noted on the plans. Relays shall be NEMA rated and Underwriters Laboratories, Inc. approved. Ratings by IEC, VDE, DIN, etc. will not be considered for this work. Relays with special voltage ratings or designated as special purpose relays shall be provided where indicated.
3. Power failure relays shall be plug-in type with special fixed mounted socket and shall be rated for the voltage supplied to the facility. The relay shall have a 20% (minimum) adjustable range below normal voltage rating and output contacts rated for 3 amps at 115 volts. Relay shall be Time-Mark No. 258B or equal by General Manufacturing Company.
4. Running time meters shall be non-reset type, 2-inch nominal diameter semi- flush mounted, synchronous a.c. motor driven type with sealed case and shall have a six-digit register for direct reading of hours and tenths. Meters installed in corrosive or wet atmospheres shall be of corrosion resistant material and gasketed for water tightness. Meters shall be rated for 60 Hz and voltage as indicated.
5. Liquid Level Control: This specification is intended to cover a complete and operational automatic pump and alarm control system that responds to the wet well level excursions. It is the specific intention of this functional requirement that a standard controller will be employed with features as herein described and that it be a fully integrated assembly.
6. Pump controller shall be a MPE 1000 Lift Station Controller or approved equivalent. See 2.16-E

B. Level Sensor:

1. The Liquid Level of the wet well shall be sensed by a VEGAPULS C221 or preapproved equivalent.
2. The sensor assembly shall be installed and connected with other system elements and placed in successful operation. It shall be provided with input power and output signal transient protection, associated control elements as specified herein and in accordance with manufacturer's instructions.
3. The Sensor shall be suspension-mounted using manufacturer's recommended mounting hardware. All hardware, bolts, nuts, and screws shall be Stainless Steel.

D. Special Hardware:

1. Nameplates provided to identify component duty or associated equipment on control centers, special panels, etc. shall be black laminated plastic type with white engraved characters as indicated and shall be fastened with screws. Adhesive attachment methods will not be acceptable.
2. Legend plates for pilot lights, switches, etc. shall reflect wording shown on the plans and shall be non-corrosive metal types fastened by the device locking ring.
3. Concrete masonry inserts shall be self-driven expansion type "Phillips Red Head" or equal by Star.
4. Padlocks shall be brass weatherproof padlock for the gate, of the four-pin tumbler type (minimum) and the Owner shall be provided with keys as noted in the Board's Standard Specifications. Padlocks shall be provided on all lockable items including:
  - a. Service disconnect and transfer switches.
  - b. Control panels.
  - c. Access hatches

E. Miscellaneous: All devices, equipment, and materials not definitely specified or noted, that are required for complete installations, shall be furnished and manufactured for the purpose intended and shall be installed in conformance with good, accepted practice for the conditions encountered. All hardware such as straps, supports, bolts and nuts shall be a minimum of 304 stainless steel.

2.21 SUBMERSIBLE PUMP SPECIFICATION SHEET:

PUMP SPECIFICATION SHEET:

Service: Sewage

Type of Pump: Submersible Non-Clog Sewage Pump Solids Handling

Capability: Raw, unscreened sewage. Discharge connection 4" (min) diameter.

Materials of Construction:

Casing: Cast iron, Class 35B with smooth surfaces

All exposed bolts & nuts: 316 stainless steel

Pump exterior: Factory sprayed with an acrylic zinc phosphate primer with a polyester resin paint finish. All surfaces in contact with sewage including the impeller other the stainless-steel surfaces shall be protected by the same factory applied primer.

Shaft: Stainless steel ANSI 431. Mechanical rotating shaft seal system. Seals shall run in an oil reservoir. Lapped seal faces must be hydrodynamically lubricated at a constant rate. The lower seal unit, between the pump and oil chamber, shall contain one stationary and one positively driven tungsten carbide ring. The upper seal unit, between the oil sump and

## SUBMERSIBLE PUMP SPECIFICATION SHEET Cont.

motor housing shall contain one stationary tungsten carbide ring and one positively driven rotating carbon ring. Each interface shall be held in contact by its own spring system. The seals shall require neither maintenance nor adjustment but shall be easily inspected and replaceable. The pump shaft shall rotate on two permanently lubricated bearings with a B-10 bearing life of 40,000 hours when operating at or near the best efficiency point.

Impeller: Cast iron, Class 35 B, dynamically balanced, double shrouded, non-clogging, single vane design.

Guide rails: Stainless steel, 1" (min.) diameter, or Engineer approved pump removal system.

Volute & Wear Ring: Volute shall be single piece design capable of passing any size solid which can pass through the impeller. Wear ring shall be stationary ring made of nitrile rubber molded with a steel ring insert.

Upper Bearing: Single row deep groove ball bearing.

All mating surfaces where watertight sealing is required shall be machined and fitted with nitrile rubber O-rings. Fitting shall be such that sealing is accomplished by metal-to-metal contact between machine surfaces. This will result in controlled compression of nitrile rubber O-rings without the requirement of a specific torque limit.

Installation: The pump shall have a discharge connection elbow connected to a vertical discharge pipe. The discharge connection elbow shall be permanently installed in the wet well along with the discharge piping. The pump shall be automatically aligned and connected to the discharge connection elbow when lowered into place and shall be easily removed for inspection or service without a need for personnel to enter the wet well.

Sealing of the pumping unit to the discharge connection elbow shall be accomplished by a simple linear downward motion of the pump. A sliding guide bracket shall be an integral part of the pump unit. The entire weight of the pumping unit shall be guided by no less than two guide bars and pressed tightly against the discharge connection elbow with metal-to-metal contact. Sealing of the discharge interface by means of a diaphragm, O-ring, or other devices will not be acceptable. No portion of the pump or the guide support system other than the discharge connection shall bear directly on the floor of the sump. The pump, with its appurtenances and cable, shall be capable of continuous submergence underwater without loss of watertight integrity to a depth of 40 ft.

A 4" (min.) cast iron discharge connection with anchor bolts, upper guide bar bracket, 20 feet of galvanized lifting chain, and 40 feet of Hypalon jacketed type SPC cable, P-MSHA approved and sized according to N.E.C. and ICEA standards shall also be provided.

SUBMERSIBLE PUMP SPECIFICATION SHEET Cont.

Drive Motor:

1. 10 Horsepower (min.) submersible, 120/230 V, 3 Phase, 4 Wire, 60 Hz or variation preapproved by owner.
2. Design: Induction, Squirrel-cage rotor, housed in an air filled, watertight chamber
3. NEMA Design - Type B
4. Windings: Copper, Class H Insulated
5. Service Factor: 1.15 continuous
6. Design Temperature: 40° C ambient (max.)
7. Non-overloading at any point on pump curve
8. Explosion Proof
9. Motor Terminal Board
10. Stator shall be heat-shrink fitted and shall be insulated by the trickle impregnation method using Class H monomer free polyester resin
11. Motor Winding Over-temperature Thermostats
12. Seal Failure Moisture Probe

Guaranteed Performance: GPM TDH RPM EFF HP

Design \_\_\_\_\_ (max.) \_\_\_\_\_ (max.)

High Head \_\_\_\_\_

Low Head \_\_\_\_\_

Warranty: The pump manufacturer shall warrant the unit being supplied to the Owner against defects in workmanship and material for a period of two (2) years unlimited hours.

Experience: Pump manufacturer's direct sales and service representative shall have local experience directly related to the proposed pumps and adjoining equipment.

Manufacturer(s): Pumps complying with the specified parameters and as included on the Owner's list of approved pump manufacturers shall be acceptable.

Model No.: (List Model Number)

2.22 EMERGENCY GENERATOR:

Wastewater lift stations shall be provided with natural gas emergency generator to meet Fairhope Utilities requirements for power reliability unless otherwise approved by the Supervisor of the Water and Sewer department. The generator shall be installed on a reinforced concrete pad, sized by the engineer in relation to the size and weight of the generator. The top of the pad shall be a minimum of 4 – inches above grade with chamfered edges. The generator shall meet the following specifications:

Provide automatically activated stand-by power generator source with automatic reset, auxiliary emergency switchgear placed on site. Pump manufacturer to provide power demand/ratings to contractor before ordering pump and the power demand appropriately marked on the pump shop drawings. Generator shall have the capacity sufficient to sequentially start and run all pumps in the pump station. The contractor shall provide a complete engine driven generator set. The generator set shall consist of four-cycle, radiator-cooled, engine direct

connected to an alternating current generator, a unit-mounted control panel, all mounted on a common sub-base.

### EMERGENCY GENERATOR Cont.

The control panel shall be complete with engine controls and instruments, safety controls and panel lights including the following:

- a. The generation unit shall be capable of powering the pump motors starting current, electrical systems, instrumentation / controls and alarm systems, and other auxiliary equipment as may be necessary to provide for the safe and effective operation of the pump station. The generation unit shall have the appropriate power rating to start and continuously operate under all connected loads.
- b. The generator shall be capable of starting, and simultaneously running, all pumps installed in the lift station.
- c. The generation unit shall be capable of shutting down and activating the audible and visual alarms and telemetry if a damaging operating condition develops.
- d. The generation unit shall be protected from damage when restoration of power supply occurs.
- e. The generator shall be equipped with an automatic transfer switch to start generator and transfer load to emergency in case of utility under voltage, over voltage, power loss, phase reversal, or phase loss. Transfer switch shall have a field-adjustable time delay in center position.
- f. The control panel shall be complete with run-stop-remote switch; remote start-stop terminals; cranking limit; battery charge rate ammeter, oil pressure gauge, temperature gauge; low oil pressure shutdown; high engine temperature shutdown; over speed shutdown; AC voltmeter; voltage adjustment; frequency meter; and running time meter.
- g. Circuit breakers shall be provided with a built-in control panel. Provide generator output circuit breaker rated in accordance with the National Electrical Code.
- h. Provide manufacturer's recommended anti-freeze, engine heaters, and suitable trickle battery charger. All accessories shall be engine mounted and within the weatherproof sound attenuated housing.
- i. The manufacturer of the unit shall completely assemble and test the unit before shipment. The manufacturer shall be one who is regularly engaged in the production of such equipment, and who has spare parts and service facilities. The manufacturer must also provide one complete set of filters.
- j. The controls must indicate engine run, common engine fail, transfer switch position, and low fuel for remote telemetry purposes.
- k. The automatic transfer switches must have a disconnect on the utility service

main side.

### EMERGENCY GENERATOR Cont.

- I. The generator shall comply with the following minimum requirements:
  - 1) Engine: Four-cycle, radiator cooled, at 1800 RPM. Starting shall be from batteries, with capability to start the unit at 32 degrees temperature.
  - 2) Generator: Rating shall be continuous standby service at 0.8 power factor, at 1800 RPM.
  - 3) Voltage & KW rated to match facility needs.
  - 4) Engine shall be equipped with a mechanical governor.
  - 5) Frequency regulation shall be less than 3-cycles from no load to full load.
  
- m. All accessories needed for the proper installation of the system shall be furnished. Included should be batteries, battery cables, exhaust piping, mufflers, vibration mounting, and three bound sets of detailed operation and maintenance manuals with parts list. Batteries should be lead acid.
  
- n. The generator set shall be enclosed with a factory-installed weather protective housing (sound abating enclosure to 68 db @ 23 ft.) Housing shall provide easy access to the engine-generator and instrument panel. Muffler to be designed so exhaust is not blown or sucked across the set by cooling air.
  
- o. Included with the generator shall be a complete fuel system, fuel gauge, fuel lines, fuel pumps, valves and any and all other items incidental to a first-quality installation.
  
- p. Provide manufactures' recommended antifreeze and engine block heater, per manufacturer's recommendations, with thermostatic controls to maintain engine coolant at proper temperature to fulfill start-up requirements, adjustable if possible. Provide suitable trickle battery charger. All accessories shall be engine-mounted and within the weatherproof sound attenuated housing.
  
- q. Provide annunciator panels with visual and audible alarms to monitor and warn of emergency operation conditions affecting line and generator power sources.
  
- r. Provide stainless steel super critical grade type exhaust silencer mounted on top of the generator enclosure for corrosion protection.
  
- s. Provide amp meter, voltmeter, and frequency meters with phase switches.
  
- t. Provide fuses or circuit breakers for battery charger and engine.

EMERGENCY GENERATOR Cont.

- u. Provide an automatic battery charger, static type, magnetic amplifier control with DC voltmeter, DC ammeter and potentiometer for voltage adjustment. The charger is to be completely automatic and rated for the type of battery use. The charging rate is to be determined by the state of the battery and reducing to milliamp current on fully charged battery. The charger shall be 120 V., single phase, 60 cycles, AC input with 6-amp maximum output.
- v. Operation and Maintenance instructions. The Contractor shall provide a minimum of 4 continuous hours of operation and maintenance instructions for the City's personnel.
- w. Fairhope Water & Wastewater must be furnished with one complete set of air, oil, and fuel filters.



STANDARD SPECIFICATIONS FOR  
CONSTRUCTING SANITARY SEWER FACILITIES  
DIVISION III - CONSTRUCTION SPECIFICATIONS

SECTION 3

REHABILITATION OF SANITARY SEWER MAINS BY THE  
CURED-IN-PLACE PIPE (CIPP) METHOD

3.01 SCOPE

It is the intent of this specification to define the approved methods and materials for the trenchless rehabilitation of existing sanitary sewer lines by the Cured-In-Place (CIPP) process.

These specifications form a part of the Contract Documents and shall govern for rehabilitating sanitary sewer mains and laterals by the cured-in-place pipe (CIPP) process. The work covered in this section includes the furnishing of all plant, labor, equipment, appliances and materials and performing all operations in connection with the complete rehabilitation of the existing deteriorated sanitary sewer system piping.

The CIPP process is defined as the reconstruction of sanitary sewer pipe by the installation of an epoxy vinyl ester or polyester resin, thermosetting resin, vacuum impregnated flexible polyester felt fiber tube, having an impermeable inner surface. The resin impregnated tube shall be formed to the host pipe by means of a water column. Curing shall be accomplished by circulating hot water throughout the length of the tube in accordance with the specified curing schedule supplied by the resin manufacturer. The CIPP shall extend the full length of the pipe reach being rehabilitated and shall provide a structurally sound, impermeable, jointless, close-fitting, pipe that when cured is mechanically bonded to the host pipe.

The Contractor shall complete all work in strict accordance with all applicable current OSHA standards. Particular attention is drawn to those safety requirements involving work on an elevated platform and entry into a confined space. It shall be the Contractor's responsibility to comply with OSHA Standards and Regulations pertaining to all aspects of the work.

When required for acceptable completion of the pipe rehabilitation or replacement, the Contractor shall provide by-pass pumping for continuous sewage flow around the section(s) of pipe designated for the installation of replacement pipe. The pump bypass lines shall be of adequate capacity and size to handle the flow in accordance with the specifications herein.

Installation methods and materials shall conform to ASTM F1216 in addition to these specifications.

### 3.02 REFERENCES

- A. ASTM D790-17(Latest Revision) – Standard Test Methods for Flexural Properties of Unreinforced and Reinforced Plastics and Electrical Insulating Materials
- B. ASTM D2990-17 (Latest Revision) – Standard Test Methods for Tensile, Compressive, and Flexural Creep and Creep-Rupture of Plastics
- C. ASTM D5813-04 (Latest Revision) – Standard Specification for Cured-In-Place Thermosetting Resin Sewer Piping Systems
- D. ASTM F1216-16 (Latest Revision) – Standard Practice for Rehabilitation of Existing Pipelines and Conduits by the Inversion and Curing of a Resin-Impregnated Tube

### 3.03 QUALIFICATIONS

- A. Mainline CIPP
  - 1. The Contractor shall provide evidence and references for successfully installing a minimum of 150,000 linear feet of CIPP in the United States of America.
- B. Lateral CIPP
  - 1. The Contractor shall provide evidence and references for successfully installing a minimum 250 CIPP lateral liners for the proposed product in the United States of America.

### 3.04 SUBMITTALS

- A. The following submittals shall be submitted prior to the work:
  - 1. MSDS sheets for all materials to be provided for this project.
  - 2. Fabric Tube manufacturer and product components description.
  - 3. Flexible membrane coating material data sheet including repair recommendations.
  - 4. Raw Resin manufacturer and product components description.
  - 5. Manufacturer's shipping, storage, and handling recommendations for all components of the CIPP system.
  - 6. Description of the proposed wet-out procedure.
  - 7. Contractor's proposed installation schedule.
- B. The following documentation shall be submitted during construction:
  - 1. Pre and Post Video Inspection videos and reports

2. Wet-Out Report
3. Curing Log

3.05 MATERIALS

- A. Resin: The Contractor shall furnish a manufacturer epoxy vinyl ester or polyester resin series resin and a compatible catalyst system to accommodate the environment of the existing sanitary sewer system. The resin manufacturer shall provide the Contractor with their recommended curing cycle and shall submit data to the Owner for approval. The CIPP when cured shall have the following minimum values when tested in accordance with ASTM F1216. Testing shall be performed by an independent testing laboratory approved by the Owner:

Physical Characteristic	Minimum Values	Test Method
Flexural Strength	4500 psi	ASTM D 790
Modulus of Elasticity	250,000 psi	ASTM D 790

Certified copies of all test reports on the properties of the selected resin, and the resulting field liner coupons performed by the independent testing laboratory shall be submitted to the Owner. A minimum of two (2) structural tests shall be performed from each installation run and one chemical resistance test per run for quality. All testing costs shall be included in the related contract unit price for CIPP.

- B. Tube: Tube material shall be supplied by the system licenser to the Contractor in accordance with Section 5.1 of ASTM F1216-16 (latest revision).
- C. CIPP Wall Thickness: The minimum CIPP thickness shall be structurally adequate to accommodate the following physical conditions of the existing pipe to be rehabilitated:
1. All pipes shall be considered fully deteriorated.
  2. All pipes shall be subjected to soil load of 120 lbs./c.ft., with applicable live load, and water table five (5) feet below the top of the ground.
  3. All pipes shall have a minimum of 2% ovality in the circumference.
  4. A safety Factor of 2.0.
  5. Flexural Modulus Retention to account for long term effects of 50%
  6. Live Loading to be considered has standard HS-20 Loading.
  7. Soil fill height shall be considered at the deepest cover segment and applied for the entire length of the pipe run.
  8. Default Soil Modulus of:
    - 700 psi for depths of 3 – 10 feet
    - 1,000 psi for depths of 10 to 15 feet or under Highway
    - 1,500 psi for depths > 15 feet or under Railroad

The following liner thicknesses shall be maintained as a minimum:

<b>TABLE 3-1 Typical Liner Thickness</b>			
SEWER DIAMETER	PIPE INVERT DEPTH UP TO 10'	PIPE INVERT DEPTH 10-15'	PIPE INVERT DEPTH 15' AND OVER
6"	4.5 mm	4.5 mm	4.5 mm
8"	6.0 mm	6.0 mm	6.0 mm
10"	6.0 mm	6.0 mm	7.5 mm
12"	6.0 mm	7.5 mm	9.0 mm
15"	7.5 mm	9.0 mm	10.5 mm
18"	9.0 mm	12.0 mm	13.5 mm
21"	10.5 mm	13.5 mm	15.0 mm
25"	12.0 mm	15.0 mm	16.5 mm
30"	15.0 mm	18.0 mm	21.0 mm
36"	16.5 mm	21.0 mm	24.0 mm
42"	19.5 mm	24.5 mm	28.5 mm
48"	22.5 mm	28.5 mm	33.0 mm

The Contractor shall verify the liner thicknesses included in Table 3-1 for correctness and advise of any variations required to accommodate the selected process and structural requirements. No additional compensation will be allowed for these variations. Any proposed adjustments to the liner wall thickness or installation procedures shall be submitted by the Contractor to the Owner for approval including design criteria, calculations and other information required to ensure the structural and hydraulic capacity of the proposed liner materials.

### 3.06 CONSTRUCTION PROCEDURES

- A. General: The following construction procedures shall be performed as a minimum. Additional procedures shall be performed to accommodate actual conditions. The general procedure shall include the following:
1. Hydraulically clean existing piping.
  2. Video inspect existing piping and locate existing laterals.
  3. Remove line obstructions, where applicable.
  4. Video pipeline immediately before lining.
  5. Perform CIPP process.
  6. Reconnect existing active laterals.
  7. Video inspect rehabilitated pipe.

- B. Preinstallation: The following preinstallation procedures shall be completed, as a minimum:
1. Cleaning Existing Piping: Existing piping scheduled to be rehabilitated shall be hydraulically cleaned prior to videotaping. All material dislodged during the cleaning process shall be completely removed from the sewer system and dumped at an approved facility. Coordination with the City of Fairhope would be required for dumping at the treatment plant.
  2. Video Inspection: A video (television) internal inspection of the cleaned existing piping shall be performed by a pan and tilt camera to assure that the piping is clean and conditions of the main and laterals are acceptable for lining. One (1) video tape of the internal piping shall be provided to the Owner for the Owner's records. The submitted video shall be captured immediately before lining operations commence. Bypass pumping and piping shall be performed by the Contractor when required to adequately view the existing piping conditions.
  3. Line Obstructions Removal: The Contractor shall remove any obstructions from within the sewer main that can be removed without excavation. Obstructions requiring excavation for removal shall be reported and performed by the Owner or as otherwise required in the contract documents.
- C. CIPP Installation: The Contractor shall submit a detailed description of the proposed techniques and procedures for rehabilitating the existing piping. The Contractor shall submit details to the Owner for approval prior to beginning work. The format shall generally conform to the following:
1. Wet Out: The Contractor shall designate a location where the felt tube will be impregnated ("wetted out") with resin using distribution rollers and vacuum, to thoroughly saturate the felt tube prior to its dispatch for installation. The Contractor shall inform the Owner, in advance, to inspect the materials and the wet out procedure. A catalyst system or additive(s) compatible with the resin and tube, may be used as per the manufacturer's recommendation provided they will not impair or reduce the resin's quality to withstand the minimum chemical resistance criteria.
  2. Insertion: The wetted out tube shall be transported and kept in a refrigerated truck, until it is inserted through an existing manhole by approved techniques/process of the installer or the Contractor. The insertion area, equipment platform, etc., shall be securely protected, and all damaged yards, driveways, walks etc., shall be repaired, at no cost to the Owner.
  3. Curing: After the insertion is completed, the Contractor shall use a hot water or steam recirculation system capable of delivering desired heat uniformly throughout the section, for a consistent cure of the resin. All water used shall be from metered supply and paid for to the through the regular billing system. The curing temperatures shall be as recommended by the resin/catalyst system of the resin manufacturer. The heat source shall be fitted with suitable monitors to gauge the temperature of the incoming and outgoing heat source. Another such gauge shall be placed between the impregnated tube and the invert to the original pipe at the manhole(s) to

determine the temperatures during the resin curing process. Initial cure shall be considered completed when the exposed portions of the felt tube pipe appear to be hard, and the remote sensing device indicates the temperatures to be adequate, as recommended by the resin/catalyst system manufacturer, and approved by the Owner. Curing temperatures and duration shall comply with previously submitted data and information.

4. Cool Down: The Contractor shall cool the hardened pipe to a temperature below 100 degrees Fahrenheit, before relieving the water column. Cool water may be added to the water column while draining hot water from a small hole at the opposite end of the CIPP, so that a constant water column height is maintained until cool-down is completed. Care shall be taken in the release of the water column so that a vacuum will not be developed, that could damage the newly installed pipe. Coupon samples shall be obtained for testing. The cool down process may vary depending on the installation technique of the manufacturer/Contractor.
5. Finished Pipe: The finished CIPP shall be continuous over the entire length from manhole to manhole and be free from visual defects such as foreign inclusions, dry spots, keel, boat hull, pinholes, wrinkles and other deformities. The liner passing through or terminating in a manhole shall be carefully cut out (also for samples) in a shape and manner approved by the Owner. The invert and benches shall be streamlined and improved for smooth flow. The area/annular space between existing and the CIPP shall be sealed with approved materials in an approved manner described later. It shall also meet the leakage requirements of pressure test specified later. Any defect which will affect the integrity or strength of the pipe discovered during the warranty period shall be repaired at the Contractor's expense.

### 3.07 CONSTRUCTION METHODS

- A. Sealing and Benches in Manhole: The CIPP shall make a tight fitting seal with the existing pipe(s) in the manhole. LMK Technologies Insignia Hydrophilic end seal sleeve 3.5 inches thick or equal shall be applied circumferentially near the annular space touching the end of existing pipe and properly encased with a cement based mortar. The top half of the pipe shall be neatly cut off, at least four (4) inches away from the walls. Breaking or shearing pipe will not be allowed. The channel in the manhole shall be a smooth continuation of the pipe(s) and shall be merged with other lines or channels, if any. The channel cross-section shall be U-shaped with a minimum height of one-half pipe diameter to three-fourths of the pipe diameter for fifteen (15) inches and larger. The side of the channels shall be built up with mortar/concrete to provide benches at a maximum of 1 in 12 pitch towards the channel.

CIPP and the existing pipe in the manhole shall be sealed as above before proceeding on to the next manhole section and all manholes shall be individually inspected for liner cut-offs, benches and sealing works.

The connection between the cured-in-place pipe and the existing manhole shall be sealed to eliminate all ground water infiltration into the sanitary sewer system at this connection.

- B. Service Reconnections: The exact location and number of service connections shall be determined from TV tapes and/or in the field. It shall be the Contractor's responsibility to accurately field locate all existing service connections whether in service or not. The Contractor shall reconnect all service connections to the liner pipe including those from unoccupied, abandoned or vacant lot, unless directed otherwise by the Owner. Each vacant lot shall also be provided with one service connection location, at an approved location. The Contractor shall be responsible for restoring/correcting, without any delay, all missed or faulty reconnections, as well as for any damage caused to property owners for not reconnecting the services soon enough or for not giving notice to the owners. All services which are reconnected to rehabilitated liner shall be shown on the "Record Drawings" with the exact distance from the nearest downstream manhole.

All existing service connections shall be reconnected either by Remote TV Controlled Cutting Device method or by Excavation method as below:

1. Service Connection by Remote Cut: Service connections may be performed by TV controlled Remote Cutting Device. They shall be made by experienced operators so that no blind attempts or holes are made in the liner pipe. Location shall be verified carefully with earlier tapes for accuracy, especially where dimples are not defined or clearly ascertained. The Owner reserves the right to require service connection by excavation at certain or all locations, at no additional cost to the Owner, if the quality, workmanship, and approval rating for remote cut is poor and not satisfactory.

The remote cut shall be brushed smooth and circular in nature as seen by a 360-degree TV camera. The hole shall be a 100% of the service pipe diameter. It shall be properly aligned and be concentric to the existing connection. The locations of all remote cuts shall be verified carefully to match earlier tapes for their exact locations. Excess wrong holes, or trial cuts shall be considered unacceptable and shall be properly repaired at no additional cost to the Owner. Excess resin build up is unacceptable and shall be removed. The Owner's staff shall review all service connections. The Owner may check the completed remote connections for the 100% requirement by excavating the site, if necessary. Defective connections shall be properly repaired at no additional cost to the Owner.

2. Service Connection by Excavation: Service connections may be performed by excavating at the exact location as exposed as an alternate. They shall be disconnected at the joints. The existing sewer, now the carrier pipe for the liner, shall be carefully broken/removed to expose the liner to the extent necessary. The liner pipe shall not be damaged and shall be allowed to normalize to ambient temperature and cool down before a 4- or 6-inch diameter hole is drilled out. This coupon shall be retrieved and delivered to the Owner for inspection of the liner thickness at that location. The cut-out hole section in the liner shall be coated with approved resin/epoxy which will cure at the ambient temperature.

A pre-fabricated polyethylene saddle or approved equal fitting shall be installed over the cut out. The saddle shall be a one-piece saddle equipped with a neoprene gasket so that a complete seal is accomplished when the strap-on saddle is tightened with two (2) stainless steel bands, one on each side. The stub-out attached to the saddle must protrude into the liner a

distance equal to the wall thickness of the liner. The new 6", or 8" stubout, or lateral, shall be connected to the existing service line by a rubber coupling with stainless steel bands, as manufactured by "Mission" or an Owner approved equal.

The "Mission" coupling shall be secured to the existing service lateral and new stub and/or stack with stainless steel bands. The entire exposed service connection shall be encased in cement stabilized sand a minimum of 6" below and 12" above and on the sides of the pipe at a cost incidental to service connection. The service connections shall be tested by the Contractor and approved by the Owner before backfilling.

Gasketed PVC sewer pipe (Schedule 40) may be used for all stubs. PVC saddles with neoprene gaskets may be used in lieu of polyethylene saddles.

A service reconnection by excavation shall consist of the removal and replacement of any cracked, offset, or leaking existing service line up to a distance of eight feet (8 ft.) from the center of the new liner measured horizontally. Eight-inch diameter services shall be connected to 8-inch sewer by the construction of a new manhole which shall be performed by others. The Contractor shall notify the Owner when an 8" diameter service is located.

One or more homes discharging into a common connection shall be considered as one service connection.

3. Removal of Protruding Service Connections: Protruding service connections or laterals that prevent the proper insertion of the liner shall be removed to allow the liner to pass through the existing sanitary sewer pipe after review and approval from the Owner. This shall be completed by a remote cutting device without excavation where applicable.
4. Lining of Service Laterals: The lateral section to be lined is defined as the connection from the sanitary sewer main to the road right-of-way (property owner's side of the sidewalk) or easement line or as directed by the Owner. The lined lateral shall include the connection of the lateral to the main.

The Contractor shall furnish a manufacturer epoxy vinyl ester or polyester resin and a compatible catalyst system to accommodate the environment of the existing sanitary sewer. The complete lateral liner system shall be as manufactured by LMK Enterprises, Inc. "T-Liner", Insituform Technologies, Inc. "Top Hat" or an Owner approved equal. The wall thickness shall be uniform.

The Contractor shall clean and inspect the lateral prior to lining. The lateral shall be free of debris and roots and shall be trimmed of any protrusion into the main. The lateral shall be inspected by internal video after the liner has been installed for acceptance.



The construction procedures shall be as described for mainline lining in this section except for curing which shall be performed by hot water or chemical cure. Inversion of the liner from the main into the lateral shall be with either water or air pressure.

<b>Physical Characteristic</b>	<b>Minimum Values</b>	<b>Test Method</b>
Flexural Strength	4500 psi	ASTM D 790
Modulus of Elasticity	250,000 psi	ASTM D 790

The liner shall be air tested at the Owner's request to a constant pressure of 4 psig greater than the average back pressure of any ground water above the pipe but not greater than 9 psig with the plugs for the air test being placed outside of the pipe to liner connections.

In the event the lateral liner installation is not acceptable to the Owner, the Contractor shall dig and replace the lateral and lateral to main connection at the Contractor's expense.

**3.08 POST TELEVISION OF COMPLETED SECTIONS**

The Contractor shall provide to the Owner a color video file taken by a 360-degree radial view camera for close up view showing the completed work, including the condition of the restored taps and lateral condition. Two (2) television inspection reports and one (1) set of video files, shall be provided to the Owner in accordance with the specifications herein.

The pre-rehab and post-rehab video files shall be dubbed onto one tape so that the post-rehab footage will directly follow the pre-rehab footage for each segment of main rehabilitated. Sewer main segments determined from pre-rehab video as not needing lining shall be on a separate file from those mains lined.

**3.09 WARRANTY**

All liner installations shall be warranted to be free from defects in materials and workmanship for a period of two (2) years from the date of project acceptance. Should a defect occur during this two (2) year period that is attributable to the liner installation or materials, then this defect shall be repaired within four (4) weeks from the date of defect notification to the contractor at no additional cost to the Owner.

The contractor shall be responsible for all required repair costs associated with a liner failure during the warranty period including all cost associated with lateral backups into buildings and all other property damage.

STANDARD SPECIFICATIONS FOR  
CONSTRUCTING SANITARY SEWER FACILITIES  
DIVISION III - CONSTRUCTION SPECIFICATIONS

SECTION 4

URETHANE/EPOXY REHABILITATION OF MANHOLES

4.01 SCOPE

It is the intent of this Specification to cover all aspects of rehabilitation of manholes including types of repair, methods of repair, materials and equipment.

Sanitary sewer manhole rehabilitation covers the following type of repairs:

- A. Lining and sealing of manhole.
- B. Replacement of manhole frame and cover.
- C. Raising of existing manhole frame and cover to existing or above grade.
- D. Inflow Dish.
- E. Chimney Seal.

4.02 LINING OF MANHOLES

- A. General: The work consists of spray applying a urethane/epoxy-based material to the walls, inverts, and benches of manholes, resulting in a monolithic liner of a minimum 1/8 inch thickness or more, as determined by the manufacturer for the specific depth and water table. The applicator, approved and trained, shall furnish all labor, equipment, and materials for installing the lining over brick, tile, pre-cast concrete, or concrete block manholes, new or used, using approved equipment. The installation shall be in accordance with the following Contract Specifications along with manufacturer's recommendations.
- B. Materials:
  - 1. Mixture: A proprietary urethane/epoxy-based material specifically designed for manhole applications shall be SprayWall as manufactured by Sprayroq, Inc., or Warren Environmental Systems M-301 and S-301 as manufactured by Warren Environmental, Inc. or Raven 405 as manufactured by Raven Lining Systems or engineer approved equal. The product shall be corrosion resistant to the ingredients of the sanitary sewer environment and shall be designed to bond to wet (not running) surfaces.
  - 2. Water: Shall be clean and potable.
  - 3. Other Materials: No material shall be used with or added to mixture without prior approval by the Owner.

C. Properties:

1. Physical:

- a. Tensile stress, ASTM D-638 6,500 psi
- b. Flexural stress, ASTM D-790 10,000 psi
- c. Flexural modules, ASTM D-790 550,000 psi

2. Liner Mix shall be made with manufacturer's recommendations for manhole applications.

D. Application:

1. Preparation:

- a. Place covers over invert before prepping.
- b. All foreign materials shall be removed from the manhole walls and bench using high-pressure water spray (minimum 1,200 psi). Loose and protruding brick, mortar and concrete shall be removed using a masons hammer and chisel. All non-leaking voids shall be filled with a nonshrink cement-based material containing hydraulic cement, as approved and directed by the Owner at least 1 hour prior to spray application of the first coat of liner.
- c. Active leaks shall be stopped using products specifically for that purpose and according to manufacturer's recommendations. Grouting with chemically resistant cement-based material shall be used to cease inflow into manholes.
- d. Excessively leaking manholes shall be drilled through the manhole wall and injected with grout sealant only after the event that normal leak stoppage methods are not effective and it is approved by the Owner.
- e. All loose material shall be removed following the completion of preparation work.
- f. The sanitary sewer shall be diverted to perform the required manhole rehabilitation.
- g. Manhole inverts and steps shall be protected during rehabilitation application.

3. Spraying:

- a. The surface prior to spraying shall be damp without noticeable free water droplets or running water. Material shall be spray applied to a minimum uniform thickness to insure that all voids and crevices are filled and a smooth.

- b. The application of the liner shall provide a monolithic liner of a minimum of 1/8". The liner shall be applied to the invert, bench and wall and shall all be equal in thickness as determined by the water table and the product manufacturer. The manhole invert and bench shall be smooth and sloped in the direction of the flow. The manhole bench shall have a gradual slope to the invert. The invert transition to the pipe shall be smooth and shall not impair the flow.
  - c. No application shall be made when ambient temperatures are less than 40oF and when freezing is expected within 24 hours unless specific recommendations are made by the manufacturer.
  - d. A minimum of 30 minutes cure time or more as required by the product manufacturer shall be allowed before returning to active flow.
- E. Testing: Two standard samples shall be taken from each day's work with the date, location and job recorded for each sample. The samples shall be sent to an established, local, and reputable commercial testing laboratory that has been approved by the Owner to determine if lining materials meet minimum requirements specified herein.

#### 4.03 LINING OF MANHOLES USING CURED-IN-PLACE EPOXY RESIN LINER

- A. General: The work consists of lowering the cured-in-place epoxy resin liner into the manhole resulting in a monolithic liner of a minimum 1/8 inch thickness or more, as determined by the manufacturer for the specific depth and water table, including the walls, inverts and benches of manhole. The applicator, approved and trained, shall furnish all labor, equipment and materials for installing the liner over brick, tile, precast concrete, or concrete block manholes, new or used, using approved equipment. The installation shall be in accordance with the following Contract Specifications along with manufacturer's recommendations.
- B. Materials:
- 1. Mixture: A proprietary cured-in-place epoxy resin liner material specifically designed for manhole applications shall be Poly-TriPlex Liner System manufactured by SunCoast Environmental International, Inc. or engineer approved equal. The product shall be corrosion resistant to the ingredients of the sanitary sewer environment and shall be designed to bond to wet (not running) surfaces.
  - 2. Water: Shall be clean and potable.
  - 3. Other Materials: No material shall be used with or added to mixture without prior approval by the Owner.
- C. Properties:
- 1. Physical:
    - a. Tensile stress, ASTM D-638 12,900 psi
    - b. Flexural stress, ASTM D-790 17,400 psi

c. Flexural modules, ASTM D-790 550,000 psi

2. Liner Mix shall be made with manufacturer's recommendations for manhole applications.

D. Application:

1. Preparation:

- a. Place covers over invert before prepping.
- b. All foreign materials shall be removed from the manhole walls and bench using high pressure water spray (minimum 1,200 psi). Loose and protruding brick, mortar and concrete shall be removed using a masons hammer and chisel. All non-leaking voids shall be filled with a nonshrink cement-based material containing hydraulic cement, as approved and directed by the Owner at least 1 hour prior to spray application of the first coat of liner.
- c. Active leaks shall be stopped using products specifically for that purpose and according to manufacturer's recommendations. Grouting with chemically resistant cement-based material shall be used to cease inflow into manholes.
- d. Excessively leaking manholes shall be drilled through the manhole wall and injected with grout sealant. Payment for this item shall be at unit price bid only after the event that normal leak stoppage methods are not effective and it is approved by the Owner.
- e. All loose material shall be removed following the completion of preparation work.
- f. The sanitary sewer shall be diverted to perform the required manhole rehabilitation.
- g. Manhole inverts and steps shall be protected during rehabilitation application. In the event that the manhole steps requiring removal, the Contract shall reinstall the steps as directed by the Owner. This shall be incidental to the lining of the manhole.

2. Lining:

- a. The surface prior to lining shall be damp without noticeable free water droplets or running water. The saturated resin liner shall be a minimum uniform thickness to ensure that all voids and crevices are filled and a smooth.
- b. The application of the liner shall provide a monolithic liner of a minimum of 1/8". The liner shall be applied to the invert, bench and wall and shall all be equal in thickness as determined by the water table and the product manufacturer. The manhole invert and bench shall be smooth and sloped in the direction of the flow. The manhole

bench shall have a gradual slope to the invert. The invert transition to the pipe shall be smooth and shall not impair the flow.

- c. No application shall be made when ambient temperatures are less than 40oF and when freezing is expected within 24 hours unless specific recommendations are made by the manufacturer.
  - d. A minimum of two hours cure time or more as required by the product manufacturer shall be allowed before returning to active flow.
- E. Testing: Two standard samples shall be taken from each day's work with the date, location and job recorded for each sample. The samples shall be sent to an established, local, and reputable commercial testing laboratory that has been approved by the Owner to determine if lining materials meet minimum requirements specified herein.

#### 4.04 REPLACEMENT OF MANHOLE FRAME AND COVER

- A. General: This section deals with the replacement of existing manhole frames and covers when new manhole frames and covers are required.
- 1. New Manhole Frame and Cover: Existing manhole frame and covers will normally be cleaned and reinstalled. Where required, the existing manhole frame and cover shall be removed and salvaged and a new manhole frame and cover installed and adjusted by the Contractor as directed by the Owner. Removing and replacement of pavement shall conform to the section of the specifications herein. New manhole frames and covers shall be provided by Owner. The contractor shall provide the Owner sufficient notice to allow for the acquisition of manhole frames and covers.

#### 4.05 SALVAGING MANHOLE FRAME AND COVER

All existing undamaged manhole frames and covers removed from the manholes shall be considered as salvaged frames and covers. These salvaged frames and covers shall remain the property of the Owner at all times after removal and delivered to the Owner.

Reasonable care shall be exercised to prevent unnecessary damage to the salvaged frames and covers.

The Contractor shall, upon removal of frame and cover, remove all grout from the salvaged frame and cover. The cover shall then be tied to the frame using a minimum of two (2) or more pieces of six (6) gauge wire.

#### 4.06 RAISING OF EXISTING MANHOLE FRAME AND COVER

Existing manholes below grade shall be raised to grade using either cast iron riser ring, brick and mortar, concrete "donut" riser, or manhole riser section as directed by the Owner.

When adjusting with brick, a maximum of 16 inches will be allowed. The mortar shall be troweled to a smooth finished. The brick shall conform to specifications herein.

4.07 INFLOW DISH

An inflow dish shall be installed when required by the Owner in manholes requiring rehabilitation. Inflow dishes shall be as specified herein.

4.08 CHIMNEY SEAL

A chimney seal shall be installed when required by the Owner in manholes requiring rehabilitation. Chimney seals shall be as specified herein.

4.09 MANHOLES LACKING BENCHES AND INVERTS

Manholes lacking benches and inverts shall require building of the bench and invert prior to performing any rehabilitation. Measurement and payment shall be determined by the cubic yards of concrete used to complete the bench and invert.

4.10 WARRANTY

All lining installations shall be warranted to be free from defects in materials and workmanship for a period of two (2) years from the date of project acceptance. Should a defect occur during this two (2) year period that is attributable to the lining installation or materials, then this defect shall be repaired within four (4) weeks from the date of defect notification to the contractor at no additional cost to the Owner.

The contractor shall be responsible for all required repair costs associated with a lining failure during the warranty period including all cost associated with backups and all other property damage.

STANDARD SPECIFICATIONS FOR  
CONSTRUCTING WATER DISTRIBUTION FACILITIES

DIVISION III – CONSTRUCTION SPECIFICATIONS

SECTION 5

GENERAL SPECIFICATIONS FOR WATER MAINS

5.01 SCOPE

These general and detailed specifications form a part of the Contract documents and shall govern the handling and installation of water piping, valves, hydrants, and accessories described herein, and as shown on the accompanying plans. Existing water distribution facilities are owned and operated by the City of Fairhope, hereinafter referred to as “Owner”. The construction methods employed in the placement of the water main and appurtenances shall be in accordance with current codes, practices and specifications of the Owner.

5.02 WORK INCLUDED

All labor, equipment, and material necessary to complete the work as stipulated herein. The Contractor shall clear and grub as necessary, remove as much of the pavement as may be necessary; excavate the trenches and pits to the required dimensions; sheet, brace and support the adjoining ground or structures where necessary; traffic control; handle all drainage or groundwater; guard the site, unload, haul, distribute, and lay the pipe fittings and accessories; rearrange the branch connections to transmission mains, or rearrange other conduits, ducts or pipes where necessary; connect new mains to existing mains; connect existing services to new mains; replace all damaged drains, mains or other structures; backfill the trench; restore the roadway surface; remove surplus excavated material; clean the site of the work; and maintain the street or other surface over the trenches. **The Developer of the subdivision shall furnish a water model for their subdivision as it stands at the time of the test, this model must be in compliance with current City of Fairhope Building Department Standards for minimum flow and pressure at the time of submittal and must be furnished to the city at the time of submittal to the planning department.**

5.03 SCHEDULE OF OPERATIONS

The Contractor shall prepare and submit to the Owner/Engineer for approval by the Owner/Engineer, prior to beginning construction, a schedule of his proposed operations outlining his sequence of pipe installation, connections to existing mains and placement of new mains in service.

5.04 MATERIALS

- A. Ductile Iron Pipe: Ductile iron pipe for water lines shall meet requirements of AWWA Specification C151 with mechanical joint or push-on joint unless specifically shown otherwise on the plans. Working pressure shall be a minimum of 250 psi.



The interior of all pipe shall be cement-mortar lined as specified in AWWA Specification C104 and the exterior shall receive an approved bituminous coating. All gaskets, bolts and lubricants shall be furnished.

Ductile iron pipe shall be centrifugally cast with minimum wall thickness in accordance with AWWA C151, latest revision, except where shown otherwise on the project plans or in the proposal.

Unless otherwise indicated by soil testing, polyethylene encasement shall be installed on all ductile iron pipe and appurtenances at all locations and shall conform to AWWA C105, latest revision, "Standard for Polyethylene Encasement for Ductile Iron Piping for Water and Other Liquids."

If it is necessary to cut ductile iron pipe, in no case shall it be cut by burning, but shall be cut by saw, cutter, abrasive wheel or other approved means.

The pressure rating, metal thickness, net weight of pipe without lining, length of pipe, name of manufacturer and letter "DI" shall be clearly marked on each length of pipe.

1. Flexible Joint Ductile Iron Pipe: Flexible joint pipe shall meet the requirements of AWWA Specification C151 and may be of the bolted or boltless type suitable for 250 psi working pressure. If bolted type pipe is used, all bolts and nuts shall be Corten Steel. The interior shall be cement-mortar lined as specified in AWWA Specification C104. The exterior of all pipe and fittings shall receive an approved bituminous coating, except the ball and machined surfaces, which shall receive a protective coating as recommended by the manufacturer. All ball joint pipe shall be assembled, lubricated and installed in strict conformance with the pipe manufacturer's recommendations.
2. Ductile Iron or Cast-Iron Fittings: Ductile iron or cast iron fittings shall be mechanical joint except where noted otherwise on the plans. Fittings shall be suitable for use at 250 psi working pressure and shall conform to AWWA Specification C110. Fittings shall be cement-mortar lined and the exterior coated with an approved bituminous coating, in accordance with AWWA Specification C104. At the Contractor's option, compact ductile iron fittings meeting AWWA C153 may be furnished.
3. Positive Restrained Joint Pipe and Fittings: Positive restrained joint pipe and fittings may be used in lieu of friction restrained fittings. Positive restrained joint pipe and fittings shall be either mechanical joint or push-on joint and shall be manufacturer's standard restrained joint. The joint shall achieve restraint by means of a positive factory made, metal-to-metal contact and shall allow full deflection of the joint when made up.
4. Friction Restrained Fittings:
  - a. Locked mechanical joint retainer glands of adequate strength to prevent movement may be used to supplement concrete backing. Locked mechanical joint retainer glands shall be ductile iron retainer glands equipped with hardened cupped end set screws of a type, which insure proper actuating of the restrained devices.

- b. Friction mechanical joint restraint may be used in lieu of locked mechanical joint retainer glands. Mechanical joint restraint shall be incorporated in the design of the follower gland and shall include a restraining mechanism which, when actuated, imports multiple wedging action against the pipe, increasing its resistance as the pressure increases. Flexibility of the joint shall be maintained after burial. Glands shall be manufactured of ductile iron conforming to ASTM A536. Restraining devices shall be of ductile iron heat treated to a minimum hardness of 370 BHN. Dimensions of the gland shall be such that it can be used with the standardized mechanical joint bell and tee-head bolts conforming to ANSI/AWWA A21 and ANSI/AWWA C153/A21, latest revision. Twist-off nuts shall be used to insure proper actuating of restraining devices. The mechanical joint restraint device shall have working pressure of at least 250 psi with a minimum safety factor of 2:1.
- c. A gasket system utilizing stainless steel locking segments molded into the gasket may be used in lieu of mechanical joint retainer glands to achieve joint restraint for ductile iron push-on pipe in sizes of 4 inches through 12 inches.

- 5. Polyethylene Sheath: Polyethylene encasement shall be installed on all ductile iron pipe and appurtenances at all locations where pipe is in contact with corrosive soil and shall conform to AWWA C105, latest revision, "Standard for Polyethylene Encasement for Ductile Iron Piping for Water and Other Liquids."

The whole of the above standard shall apply with the following stipulation:

Class A polyethylene encasement shall not be exposed to sunlight longer than 7 days. In situations where the polyethylene encasement is expected to be exposed to sunlight longer than 7 days, Class C polyethylene shall be required.

No polyethylene encasement shall be installed on pipe with bonded joints.

Contractor shall furnish written certification, accompanied by a copy of test results, that the pipe and pipe material has been sampled, tested, and inspected as required. These certifications and test results shall be submitted, in five complete copies, to the Owner/Engineer for review and the pipe manufacturer shall retain duplicate copies of all test results in permanent files to be made available upon request.

Care shall be taken not to damage the polyethylene sheath during the backfill operation. Any polyethylene sheath, which is damaged, shall be replaced or repaired by the Contractor at no additional expense to the Owner.

**B. PVC Plastic Pipe for Water Lines :**

- 1. Polyvinyl chloride (PVC) plastic pipe for diameter sizes less than 4-inch shall conform to the requirements of ASTM D2241, "Poly(Vinyl Chloride) (PVC) Pressure-Rated Pipe (SDR PR Series)".

Pipe shall have a minimum pressure rating of 250 psi with a Standard Dimension Ratio of 18 or heavier. Pipe joints shall be integral bell and spigot type with rubber ring sealing gasket. Lubricant for making joints shall be non-toxic, and shall be as recommended by the pipe manufacturer. The pipe bell shall be designed to be at least as strong as the pipe wall. Standard lengths shall be 20 feet except that 15 percent of total footage for a particular project may be random lengths of not less than 10 feet each.

For all PVC pipe, the Contractor shall furnish written certification, accompanied by a copy of test results, that the pipe and pipe material has been sampled, tested, and inspected as required in ASTM D 2241. These certifications and test results shall be submitted, in five complete copies, to the Owner/Engineer for review and the pipe manufacturer shall retain duplicate copies of all test results in permanent files to be made available upon request. The tests and certifications shall be of such frequency as to be representative of the entire Project.

2. Markings of PVC Piping – Marking on the pipe shall include the following, spaced at intervals of not more than 5 feet:
  - a. Nominal pipe size and OD bore
  - b. Type of plastic material
  - c. Dimension Ratio
  - d. Pressure Class
  - e. Manufacturer's name or trademark
  - f. National Sanitation Foundation (NSF) seal of approval for drinking water
  
3. Tracer Wire for PVC Pipe – All PVC pipe shall be marked using a tracer wire buried between 3 and 6 inches above the top of the pipe. The tracer wire shall be No. 12 copper wire with plastic coating. The pipe trench shall be backfilled to approximately 3 inches over the top of the pipe then the tracer wire shall be placed over the top of the pipe. Backfill shall be carefully placed to a depth of 3 inches by hand to assure that the wire is secured in place over the pipe. It is the intent to provide a means to locate PVC pipe using standard pipe locating equipment. The wire shall be carried up through valve boxes and terminated at least 2 feet above the ground line to permit connecting of locating equipment. Excess wire at valve boxes shall be neatly rolled and stored in the valve box for easy accessibility.
  
4. Marking Tape for PVC Pipe - All PVC pipe shall be marked using a nonmetallic tape buried at least 15 inches above the top of the pipe. Water mains shall be marked with blue tape. Tape shall be 3 inches wide minimum and on the Owner's list of materials and approved manufacturers. After the tracer wire has been placed, the pipe trench shall be backfilled to approximately 15 inches over the top of the pipe then the nonmetallic tape shall be placed flat over the top of pipe. Backfill shall be carefully placed to a depth of 3 inches by hand to assure that the tape is secured in place over the pipe. It is the intent to provide a visible marker in the event of excavation near a water line.

5. Fittings for PVC Pipe – Fittings for PVC pipe shall be ductile iron or cast-iron fittings as specified for ductile iron pipe. PVC fittings may be used in 2-inch PVC water lines only and will not be paid for separately. PVC fittings shall be the standard design of the manufacturer supplying pipe and shall conform to the provisions of these Specifications governing the manufacture of PVC pipe. Special PVC to C.I. pipe adaptors shall be provided for connecting PVC pipe to cast iron or ductile iron pipe or fittings, where required.
6. Restrained Joint Fittings – Where restrained joint fittings are required with PVC water pipe, ductile iron pipe shall be used in lieu of PVC and restrained joint fittings shall be as specified for ductile iron pipe.

C. High Density Polyethylene (HDPE)

Pipe shall be made from high density polyethylene resin compound which meets ASTM D1248. Pipe shall be on the Owner's list of materials and approved manufacturers. Dimensions and workmanship shall conform to ASTM F714.

The polyethylene pipe shall be the nominal pipe size and dimension ratio shown on the plans, or in the proposal. Installation shall be in accordance with ASTM D2321 or as modified herein.

Shipping lengths of pipe shall be assembled into one continuous length at the job site by thermal butt-fusion. Fusion machine and fusion machine operator shall be approved by pipe manufacturer. The resultant joint shall be as strong as the intervening lengths.

Jointing of pipe and installation of outlets shall be in accordance with the pipe manufacturer's written recommendations. The pipe manufacturer shall provide the services of a trained representative to instruct the Contractor's forces in the proper techniques for jointing of pipe and the installation of outlets or other items.

Contractors shall provide written certification from the manufacturer that the personnel performing the joint welding has received proper training for the welding of the manufacturers piping material.

Installation of polyethylene pipe in areas where flotation is probable whether on land or a subaqueous location installation shall conform with manufacturer's recommendation.

Polyethylene pipe shall not be crimped in any way during construction.

Fabricated polyethylene bends shall be manufactured by pipe manufacturer. SDR of fabricated polyethylene bends shall be equal to SDR of connecting pipe.

When connecting polyethylene pipe to manholes provide a rubber ring water seal between pipe and manhole. Grouting around the ring shall also be required inside and outside the manhole.

Deflection of polyethylene pipe after installation and backfilling shall not exceed 5 percent.

D. Encasement Pipe:

1. General: Steel encasement pipe shall conform to AASHTO Standards and Alabama Department of Transportation standards where placed under highways and to AREA 1-5-B where placed under railroads. Except where noted on the plans, encasement pipe shall be installed by a dry boring method in which the casing pipe is placed simultaneously with the boring action.  
The Contractor shall inspect the roadway or track directly above the Work before, during, and after the placing of the encasement for settlement. If settlement occurs, the Contractor shall, at no additional expense to the Owner, bring the roadway surface to its original grade by means approved by the State Highway Department or realign the track to its proper grade by means approved by the railway owner.
2. Material: Welded Steel Encasement Pipe shall be of the size and wall thickness shown on the plans and shall conform to ASTM Designation A252, Grade 2 and the Alabama Department of Transportation standard specifications. The pipe shall be coated on the outside only with a coal tar primer coat followed by a single application of hot coal-tar enamel 3/32 inches thick  $\pm$  1/32 inches and a bonded 15-pound composition felt wrap or approved equal. At the option of the Contractor, uncoated pipe may be used subject to approval of the State Highway Department or railway company provided the wall thickness is at least 0.063 inch greater than shown on the plans or in the proposal.
3. Encasement Spacers: Encasement pipe spacers and their accessories shall be used to maintain separation of the encasement pipe and the carrier pipe. The installation and spacing from center to center of encasement spacers shall be in accordance with the manufacturer's requirements. Spacers shall be stainless steel.
- 4 Encasement End Seals: Encasement end seals shall be 1/8-inch synthetic rubber, stainless steel sipper or closer, pressure molded to the rubber and a rubber protective strip attached to the seal under the zipper.

Seals shall be secured to encasement using ½ inch stainless steel “Band-It” clips or thumbscrew banding clips with a polyethylene strip placed under each clip. a telescopic fold shall be placed in the seal before banding to assure proper flexibility between the carrier pipe and the casing.

E. Gate Valves:

1. Resilient Seated Gate Valves – All valves shall be non-rising stem for underground directional burial service and shall close when the operating nut is turned in clockwise rotation. Valves shall be in accordance with and meet the requirements of AWWA C509. O-ring seals shall be provided, and the valve shall be a compression resilient seated gate valve. Disc shall be SBR coated. Valve body shall be fusion-epoxy bonded inside and out. Valves shall be furnished complete with necessary gaskets, bolts and nuts as needed for mechanical joint ends.

Mechanical joints and accessories shall comply with the latest published AWWA C111. Gaskets shall be of best grade quality of a type suitable for potable water service.

- a. Valves (12 inches and smaller): Each valve shall have mechanical joint bell ends. Valve shall be installed with the operating stem in the vertical position. Valve stem shall be furnished with 2-inch square water works nut.

F. Butterfly Valves:

1. General – Butterfly valves shall be rubber seated for 150 psi minimum working pressure and line velocities up to 16 fps. The bodies of all valves shall be cast iron construction of ASTM A126, Class B, or ASTM A48, Class 40. Underground valves shall be provided with operators with noncorrosion type of construction for input shaft, seals, bushings and bolting. Operators shall be totally enclosed and permanently lubricated for direct burial of the valves and frequent submergence in water up to 20 feet of head. The operators shall open the valves on a counterclockwise rotation of the nut wrench which shall be AWWA 2-inch square cast iron. The valve ends shall be mechanical joint in accordance with AWWA C111, except where indicated otherwise on the plans or in the proposal.

Except as modified herein, the butterfly valves and operators shall meet, or exceed, the applicable requirements of the “Specifications for Rubber Seated Butterfly Valves,” AWWA C504, for Class 150B.

2. Stuffing Boxes – All butterfly valves shall be provided with O-ring seals, nonadjustable stuffing boxes, and shall be self-sealing or self-adjusting type, which can be replaced without the necessity of removing the valve or the valve shaft from its pipeline location.
3. Valve Shafts – The valve will be installed with the valve shaft in a horizontal position. The shaft shall be of 18-8 stainless steel, Type 304. A machined, one piece, high tensile steel hexagonal shaft fitting on a matching opening through the valve disc, completely sealed from the pipeline contents with Type 304 stainless steel bushings, will be

acceptable. Valve disc shall be keyed or pinned securely to the valve shaft. Pins, wedges and accessories shall be 18-8 stainless steel, Type 304 or 316.

4. Valve Discs – The material for valve discs may be ductile iron ASTM A536 or ASTM A48, Class 40, cast iron.
  5. Valve Seats – The mating seat surfaces shall be 18-8 stainless steel on natural rubber.
- G. Tapping Valves and Sleeves: Tapping valves shall meet the requirements set forth for gate valves as described in these Specifications. Tapping sleeves being 8" and smaller shall have a working pressure of 250 psi and larger sleeves shall have a working pressure of 200 psi. Tapping sleeves shall be Romac SST Stainless Steel or equivalent meeting ASTM D 2000MA610.
- H. Fire Hydrants: All hydrants shall be Mueller, M & H, or equivalent. Size of hydrant valve shall be 5¼ inches minimum. All hydrants shall have two 2½ inch bronze hose nozzles and on 4½ inch bronze pumper nozzle and shall be designed for 250 psi working pressure and 400 hydrostatic test pressure and shall conform to the latest Specifications of the AWWA C502. All working parts shall be bronze. All hose threads shall be National Standard fire hose coupling threads. On 2½ inch outlet, there shall be 7½ threads per inch. On 4½ inch pumper nozzle, there shall be 4 threads per inch. Hydrants shall have a mechanical joint end inlet. Fire hydrant main valve shall open against water pressure and close with water pressure. Operating threads shall be isolated from hydrant waterway completely by O-ring seal plate. Fire hydrants shall be equipped with traffic break away feature.

Hydrants shall utilize three-quarter inch (3/4") bolts meeting ASTM A-307 Grade b, zinc coated by the hot dip process, in accordance with the requirements of Class C of Specification A 153, to secure the lower barrel to the hydrant shoe or type 316 Stainless Steel bolts must be used if the bolts are less than ¾" in diameter.

Hydrants shall be of the three-way design with the upper barrel capable of full 360-degree rotation by any degree.

Hydrants shall have a 1-1/2" pentagon, one-piece operating nut and open left. Protection from weather shall be accomplished by one or both of the following methods:

1. A weather cap made of cast iron and firmly attached to the operating nut by means of a screw passing through the center of the weather cap and into the top of the operating nut. The base of the weather cap shall be larger in diameter than the diameter of the hold down nut. The weather cap shall be of a type that can be easily removed for maintenance and will provide tamper resistance. The bronze hold down nut will have a weather seal preventing water entry.
2. An exterior rubber seal to prevent water entry and a redundant interior rubber seal for additional protection. (2 separate seals)

Hydrants shall allow for the easy installation of barrels or extensions at the hydrant shoe or groundline without having to shut off the water main.

Friction losses through the hydrant shall not exceed 7.6 psi at 1500 gpm or 3.0 psi at 1000 gpm through the pumper nozzle, and 1.25 psi at 500 gpm through two (2) hose nozzles when tested simultaneously as outlined by AWWA C-502. Flow test results indicating the friction losses through the hydrant shall not be older than 12 months from the date said results are requested by the Owner. Flow tests must be conducted by an independent lab. Each manufacturer must provide written certification, if requested, that their hydrants meet all of the Owner's hydrant specifications.

All hydrants shall have a minimum 5-year warranty, a copy of which is to be made available on demand, identified from the cast date on the upper barrel of the hydrant.

Design, materials and workmanship shall be similar and equal to the latest stock pattern ordinarily produced by the manufacturer and the hydrants shall be of the same general type as hydrants in the existing system.

Hydrants shall be painted the Owner's standard color of red and in accordance with the requirements of AWWA C502. The outside of the hydrant top section shall receive 1 coat of shop applied primer (Fed. Spec. TT-P-86-Type IV, TT-P-636, or equal). After hydrant is installed, it shall be cleaned and primer applied to scraped or abraded areas. Hydrant shall receive an intermediate coat and a final coat of paint meeting Federal Specification TT-E-489 applied to a dry thickness of 2 mils per coat.

Hydrants shall be furnished for a bury of 4'-0" (3'-6" cover) except where otherwise required in the field and/or called for on the plans.

- I. Air Release Valves: Air release valves shall be located at high points in the line and shall be properly sized for the installation. Flanged fittings shall comply with AWWA C110 and have ANSI B16.1, Class 125, flanges.
- J. Valve Boxes: Cast iron valve boxes shall be provided for all valves installed vertically and shall consist of a base covering the operating nut and head of the valve, a vertical shaft of at least 5¼ inches in diameter, and a top section extending to a point even with the finished ground surface, provided with a cast iron cover marked "Water" and placed concentrically over the operating nut.
- K. Valve Stem Extensions: All valves in which the operating nut is greater than 3 feet below the normal ground or road surface shall be provided with extension stems to bring the operating nut to within 3 feet of the finished grade. The extension stem shall be provided with a 2-inch square operating nut on top and a coupling to connect the extension to the operating nut of the valve. A stem guide shall be provided to keep the valve stem extensions concentric with the valve box. Extension stems shall be of the same diameter as the valve stem unless otherwise specified.



- L. Anchoring Tees: Ductile iron and cast-iron anchoring tees shall meet the requirements for ductile iron or cast iron fittings, and shall be "Plain End" mechanical joint fittings with integral follower gland.
- M. Rustproof Rods for Anchorage: The threaded rods for anchorage shall be mild steel conforming to ASTM A36. The rods shall be brushed clean of all rust and foreign matter and completely coated with "No-Oxide" or approved equal before backfilling.
- N. Formed Concrete: The minimum compressive strength required at 28 days is 3,000 pounds per square inch. Field specimens and laboratory tests shall be made in accordance with the standards of the American Society of Testing Materials. The minimum amount of water shall be used to produce a workable mix and shall not exceed 6 U.S. gallons per sack of cement.
- O. Crushed Slag or Crushed Stone: Crushed slag or crushed stone shall be screened, washed and shall be 100 percent retained by a ¼ inch screen. One hundred percent shall pass a 1½ inch opening and shall be uniformly graded from maximum size to minimum size. Foreign matter shall not exceed 3 percent by weight when dry.
- P. Water Meters (5/8" x ¾" through 2"): Water meters will meet or exceed the requirements of AWWA Specification C700, latest revision, and an affidavit of compliance and certificate of testing for accuracy will be furnished. Meters may be either nutating disc, positive displacement, or oscillating piston. Frost protection will not be required. Registers shall be hermetically sealed, magnetic drive, with straight reading in U.S. gallons. Serial number will be imprinted on the case as well as on the register box lid. Materials used for meters shall be as specified in AWWA Specification C700.
- Q. Back Flow Devices shall meet AWWA Specifications C510, C511 or C512, whichever is applicable to the type of device used.
- R. Meter Boxes: Water meter boxes will be plastic with iron reader lids or concrete with cast iron lids. Boxes will be sufficient to size to house the meter and curb stop.
- S. Service Saddles: Service saddles shall be the Romac 202 NS Nylon Coated Ductile Iron Service Saddle with Stainless Steel double strap with neoprene gasket for 4 inch and larger to fit PVC and Ductile Iron Pipe.
- T. Corporation Stops: Corporation stops where required or directed, stops shall be designed for minimum pressure of 175 psi and shall have standard CC Corporation Stop Thread on inlet as specified by AWWA C800, and copper tubing size O.D. outlet suitable for service piping. Corporation stops shall be Ford Ballcorp FB-1000 series with grip nut or approved equivalent. Corporation stops shall be tapped into water mains only by means of a service saddle. Service saddles shall be Romac 202 NS style or equal.
- U. Pressure Regulating/Sustaining Valves: Shall be a CLA-VAL 90G-20BSYKCG, or Owner approved equal. Pressure settings shall be as approved by the Owner. Valve shall include open/close limit switch. Provide reinforced concrete vault with removal top section and cast iron access cover. Valve setting shall include

sleeve to facilitate valve removal, 3/8" NPT taps (plugged) each side of pressure regulatory/sustaining valve and isolation valves.

- V. Fire Hydrant Location Markers: At each fire hydrant location, blue deflectors shall be installed in the street to mark the location of the fire hydrant. The reflectors shall be Stimpsonite 2-Way Blue or an approved equal. One reflector shall be installed in the middle of the traffic lane closest to the hydrant. The reflector shall be located at a position where a line passing through it and the fire hydrant will be perpendicular to the centerline of the road. If the fire hydrant is located at an intersection, a reflector shall be placed in each of the two streets forming the intersection.
- W. Curb Stops: Curb stops shall be designed for minimum pressure of 175 psi and suitable for service piping and shall be Ford B43-332 RGW-NL or equivalent. Curb stop shall have padlock wing and "365" degree valve operation with no stops.
- X. Service Tubing: Service tubing shall be continuous from corporation stop to house service conforming to applicable requirements of ASTM B88, Type K for copper service pipe or a preapproved equivalent.

#### 5.05 INSPECTION

- A. Of Material at Factory: All materials are subject to inspection and approval at the plant of the manufacturer.  
  
All material shall meet the requirements specified and suppliers of pipe and fittings shall furnish, in triplicate, to the Owner, an affidavit stating that all pipe and fittings furnished under this Contract conforms to the requirements as set forth in these Specifications.
- B. Of Materials at Delivery Point: During the process of unloading, all pipe and accessories shall be inspected by the Contractor for loss or damage in transit.
- C. Field Inspection: All pipe and accessories shall be laid, jointed, tested, for defects and for leakage with pressure in the manner herein specified and in the presence of the Owner/Engineer or his authorized representative.
- D. Disposition of Defective Material: All material found during the progress of the Work to have flaws or other defects will be rejected and shall be promptly removed from the site of the Work.

#### 5.06 HANDLING PIPE AND ACCESSORIES

- A. Care: Pipe, fittings, valves, hydrants, and other accessories shall, unless otherwise directed, be unloaded at the point of delivery, hauled to and distributed at the site of the Project. They shall at all times be handled with care to avoid damage. In loading and unloading, they shall be lifted by hoists or slid, or rolled on skidways in such manner as to avoid shock. Under no circumstances shall they be dropped. Pipe handled on skidways must not be sided or rolled against pipe already on the ground.

- B. At Site of Work: In distributing the material at the site of the Work, each piece shall be unloaded opposite or near the place where it is to be laid in the trench.
- C. Care of Pipe Coating: Pipe shall be handled in such manner that a minimum amount of damage to the coating will result. Damaged coating shall be repaired in accordance with the pipe manufacturer's recommendations.
- D. Bell Ends, How Faced: Pipe shall be placed on the site of the Work parallel with the trench alignment and with bell ends facing the direction in which the Work will proceed.
- E. Pipe Kept Clean: The interior of all pipe, fittings and other accessories shall be kept free from dirt and foreign matter at all times. Each pipe shall have a swab run through it until all foreign matter has been removed.
- F. Frost Protection: Valves and hydrants before installation shall be drained and stored in a manner that will protect them from damage by freezing.

#### 5.07 REMOVING AND REPLACING PAVEMENT

- A. General: All paved streets and other paved areas cut by these operations shall be repaved in a workmanlike manner as shown or specified. All work shall be performed in accordance with the Alabama Department of Transportation's current standard specifications. Prior to excavation in paved street or other paved areas, the pavement shall be cut along straight and perpendicular lines parallel to the centerline of the pipe. Upon completion of the pipe laying, backfill shall be placed as required by these specifications. Immediately prior to repaving, jagged edges shall be squared and cut to a string line so that the pavement replacement will present a neat appearance. Centerline strips or other pavement markings which existed prior to the start of construction shall be replaced. No separate payment will be made for striping or marking.

The term "Pavement" shall be construed to mean either concrete, bituminous, cobblestones, or brick placed as wearing surface in streets, driveways, or sidewalks, or placed as slope protection for ditches or drains.

- B. Removing and Replacing Bituminous Base Course: Pipe trenches at paved surface crossings shall be backfilled with select or other stable material and compacted at near optimum moisture content to a minimum density of 95% of AASHTO T-99 placed evenly on each side of the pipe to the top of the subgrade elevation. Six inches (6") of an approved 4000 psi concrete mix and in accordance with the State of Alabama Highway Department Specifications, latest edition, shall then be constructed. For bituminous and concrete pavement replacement for street crossings, compaction tests shall be performed by a certified testing lab at two (2) foot increments vertically and at sufficient intervals along the trench to verify that density requirements have been achieved. Copies of certified lab reports shall be submitted to the Engineer, verifying that the backfill and base material meet the requirements of the contract specifications. Immediately following the completion of the required backfill and concrete base trench construction, the top two (2) inches of the trench shall then be filled with a Superpave Bituminous Concrete Wearing Surface Mix 424, ESAL Range C 1/2" maximum aggregate size, flush with the road surface and continuously maintained for a period of one (1) to six (6) months, as directed by the Engineer.

- C. Bituminous Wearing Surface: The following procedure shall then be followed at the completion of the maintenance period for the Bituminous Base Course, as directed by the Engineer. Jagged edges shall be squared and cut to a neat line with an appropriate saw. The edges of the pavement shall be cut along straight lines parallel to the center of the pavement cut.

Upon completion of the repaired backfill and base course trench construction, a tack coat using SS1 or SS1h emulsified asphalt shall then be applied at a rate of 0.05 gallons per square yard to the full trench width. An approved bituminous flexible Pavement Wearing Layer, Mix 429-A, shall then be constructed at one hundred and twenty-five (125) pounds per square yard. It is intended for water mains in streets to be constructed in one lane and therefore requiring resurfacing of only one half of the existing street extending from the nearest edge to the center line. Care shall be taken to assure a smooth transition at each edge of pavement flush with the road surface at roadway crossing and at all other transition locations, as shown in the plan details.

After resurfacing, the Contractor shall warranty the pavement for two (2) years. Any pavement failure that occurs during this period shall be replaced at the Contractor's expense, including removing and replacing subgrade material, if necessary. Copies of certified lab reports verifying that the construction materials used meet the project specifications shall be submitted to the Engineer.

#### 5.08 ALIGNMENT AND GRADE

- A. General: All pipe shall be laid and maintained to the required lines and grades with fittings, valves, and hydrants at the required locations, with joints centered and spigots home, and with all valve and hydrant stems plumb.
- B. Protecting Underground and Surface Structures: Temporary support, adequate protection and maintenance of all underground and surface utility structures, drains, and other obstructions encountered in the progress of the Work shall be furnished by the Contractor at his own expense.
- C. Deviation with Engineer's Consent: No deviation shall be made from the required line or grade except with the written consent of the Engineer.
- D. Subsurface Explorations: Whenever necessary to determine the location of existing pipes, valves, or other underground structures, the Contractor shall examine all available records and shall make all explorations and excavations for such purpose. This investigation shall be made in advance of any pipe laying.
- E. Depth of Pipe Cover: All pipe shall be laid to the depth shown or described, measured from the proposed or established street grade or the surface of the permanent improvement to the top of the barrels of the pipe.

Pipes 16 inches and larger shall have minimum cover of 48 inches, and pipes smaller than 16 inches shall have minimum cover of 30 inches, except where otherwise noted on the plans. At street intersections or where the new pipelines cross existing or proposed underground lines at the approximate same depth as the new line, the cover shall be increased and the new line laid below the existing or proposed pipelines. Where the new pipeline crosses existing or proposed

ditches, the top of the pipe shall be a minimum of 36 inches below the existing or proposed invert of ditch, whichever is lower, except where noted on the plans.

#### 5.09 EXCAVATION AND PREPARATION OF TRENCH

- A. Description: The trench shall be dug to the alignment and depth required and only a minimum distance in advance of pipe laying. The trench shall be so drained that workmen may work therein efficiently. It is essential that the discharge of water pumped from the trench be led to natural drainage channels or storm drains and not discharged to sanitary sewers unless otherwise approved.
- B. Width: The trench width may vary with and depend upon the depth of trench and the nature of the excavated material encountered, but in any case shall be of ample width to permit the pipe to be laid and jointed properly and the backfill to be placed and compacted properly. The minimum width of unsheeted trench shall be 18 inches, and for pipe 10 inches or larger, at least 1 foot greater than the nominal diameter of the pipe. The maximum clear width of trench shall be not more than 2 feet greater than the pipe diameter.
- C. Pipe Foundation in Good Soil: The trench, unless otherwise specified, shall have a flat bottom, conforming to the grade to which the pipe is to be laid. The pipe shall be laid upon sound soil cut true and even so that the barrel of the pipe will have a bearing for its full length.
- D. Correcting Faulty Grade: Any part of the trench excavated below grade shall be corrected with approved material, thoroughly compacted.
- E. Pipe Foundation in Poor Soil: When the bottom uncovered at subgrade is soft and cannot support the pipe, a further depth shall be excavation and refilled with suitable material to pipe foundation grade as necessary. Material used for backfill to the elevation of the pipe will be paid separately.
- F. Bracing: In the event that the Contractor or his surety deems it necessary, desirable, or for other reasons to open sheet or close sheet the trenches, the sheeting shall be accomplished in such a manner that the pipe will be protected at all times. Such sheeting shall remain in place until the backfill is carried to a point at least 2 feet above the top of the pipe. The Contractor shall exercise every precaution in removing the sheeting in order to avoid damaging the pipe. Should there be evidence that the removal of sheeting would damage the pipe, the sheeting shall be left in place. The top of sheeting left in place shall be at least 12 inches below the finished ground. There will be no direct payment for this item.
- G. Care of Surface Material for Re-Use: If local condition permit their re-use, all surface material suitable for re-use in restoring the surface shall be kept separate from the general excavation material.
- H. Manner of Piling Excavated Material: All excavated material shall be piled in a manner that will not endanger the Work and that will avoid obstructing sidewalks

and driveways. Gutters shall be kept clean or other satisfactory provisions made for street drainage. Also, storm drains shall be kept clear.

- I. Bell Holes Required: Bell holes of ample dimensions shall be dug in earth trenches at each joint to permit the jointing to be made properly.
- J. Trenching by Machine or by Hand: The use of trench-digging machinery will be permitted, except in places where operation of same will cause damage to trees, buildings, or existing structures above or below ground, in which case hand methods shall be employed.
- K. Barricades, Guards, and Safety Provisions: To protect persons from injury and to avoid property damage, adequate barricades, construction signs, warning devices, and guards as required shall be placed and maintained during the progress of the construction work and until it is safe for traffic to use the trenched highway. Rules and regulations of the respective safety provisions shall be observed.
- L. Traffic and Utility Controls: Excavations for pipe laying operations shall be conducted in a manner to cause the least interruption to traffic. Where traffic must cross open trenches, provide suitable bridges at street intersections and driveways. Hydrants under pressure, valve pit covers, valve boxes, curb stop boxes, fire or police call boxes, or other utility controls shall be left unobstructed and accessible during the construction period.
- M. Flow of Sewers and Drains Maintained: Adequate provisions shall be made for the flow of sewer, drains and water courses encountered during construction, and the structures which may have been disturbed shall be satisfactorily restored upon completion of the Work.
- N. Property Protection: Trees, fences, poles and all other property shall be protected unless their removal is authorized; and any property damaged shall be satisfactorily restored.
- O. Interruption of Water Service: No valve or other control on the existing system shall be operated for any purpose without approval of the Owner, and all consumers affected by such operation shall be notified at least 1 hour before the operation and advised of the probable time when the serviced will be restored.

#### 5.10 PIPE LAYING

- A. Manner of Handling pipe and Accessories Into Trench: Proper implements, tools and facilities shall be provided and used for the safe and convenient prosecution of the Work. All pipe, fittings, valves, and accessories shall be carefully lowered into the trench, piece by piece, by means of derrick, ropes or other suitable tools or equipment, in such manner as to prevent damage to pipe or pipe coating. Under no circumstances shall pipe or accessories be dropped or dumped into the trench.
- B. Pipe Kept Clean: All foreign matter or dirt shall be removed from the inside of the pipe before it is lowered into its position in the trench, and it shall be kept clean by approved means during and after laying.

- C. Laying Pipe: After placing a length of pipe in the trench, the joint shall be held around the bottom of the spigot so that it will enter the bell as the pipe is shoved into position. Joint material shall meet regulations of agency having jurisdiction.
- The spigot shall be centered in the bell, the pipe shoved into position, and brought into true alignment; it shall be secured there with earth carefully tamped under and on each side of it, except at the bell holes. Care shall be taken to prevent dirt from entering the joint space.
- D. Preventing Trench Water from Entering Pipe: Whenever pipe laying is stopped for the night or for any other cause, the end of the pipe shall be securely closed with a stopper to prevent the entrance of water, mud or other obstructing matter, and shall be secured in such manner as to prevent the end pipe from being dislodged by sliding or other movement of the backing.
- E. Cutting Pipe: Cutting of pipe for inserting valves, fittings, or closure pieces shall be done in a neat and workmanlike manner without damage to the pipe.
- F. Bell Ends to Face Direction of Laying: Pipe shall be laid with bell ends facing in the direction of laying. For lines on an appreciable slope, bells shall face upgrade.
- G. Permissible Deflection at Joint: Wherever necessary to deflect pipe from a straight line, either in the vertical or horizontal plane, to avoid obstructions, to plumb stems, or where long radius curves are permitted, the degree of deflection shall be in accordance with the pipe manufacturer's recommendations.
- H. Railroad and Highway Crossing: When any railroad and/or highway is crossed, all precautionary construction measures required by the railroad and/or highway officials shall be followed.
- I. Unsuitable Conditions for Laying Pipe: No pipe shall be laid in water, or when the trench conditions or weather is unsuitable for such work. Remove any water which may be found or may accumulate in the trenches and shall perform all work necessary to keep them clear of water while the foundations are being laid, the masonry being constructed, or pipe laying is in progress. Such water removal shall be accomplished by means of a well point system or other approved means. Comprehensive plans for dewatering operation, if used, shall be submitted prior to installation. Unless otherwise stated, no extra payment will be made for dewatering.

#### 5.11 JOINTING PIPE

Mechanical, push-on, or other type joints shall be installed in strict accordance with the recommendations of the joint manufacturer.

#### 5.12 SETTING VALVES, VALVE BOXES, FITTINGS AND BLOW-OFFS

- A. General: Gate valves and pipe fittings shall be set and jointed to a new pipe in the manner specified for cleaning, laying and jointing pipe.

- B. Valve Boxes: Cast iron valve boxes shall be firmly supported and maintained, centered and plumb over the wrench nut of the gate valve, with box cover flush with the surface of the finished pavement or at such other level as may be directed.
- C. Back-Siphonage to be Prevented: Drainage branches or blow-offs shall not be connected to any sewer or submerged in any stream or be installed in any other manner that will permit back-siphonage into the distribution system.

### 5.13 SETTING HYDRANTS

- A. General Location: Hydrants shall be located in a manner to provide complete accessibility, and in such manner that the possibility of damage from vehicles or injury to pedestrians will be minimized in accordance with AWWA Manual M31, latest edition. Unless otherwise directed, the setting of any hydrant shall conform to the following.
  - 1. Location Re-Curb Lines – When placed behind curb, the hydrant barrel shall be set so that no portion of the pumper or hose nozzle cap will be less than 18 inches nor more than 30 inches from the gutter face of the curb, or less than 20 feet from the curb line intersection of any street.
  - 2. Location Re-Sidewalk – When set in the lawn space between the curb and the sidewalk, or between the sidewalk and the property line, no portion of the hydrant or nozzle cap shall be within 12 inches of the sidewalk.
- B. Position of Nozzles: All hydrants shall stand plumb and shall have their nozzles parallel with or at right angles to the curb with the pumper nozzle pointing normal to the curb except that hydrants having hose nozzles at an angle of 45 degrees shall be set normal to the curb. They shall conform to the established grade, with nozzles at least 12 inches above the ground.
- C. Connection to Main: Each hydrant shall be connected to main pipe with a 6-inch ductile iron branch. Each fire hydrant shall be controlled by an independent 6-inch gate valve.
- D. Drainage at Hydrant: Wherever hydrants are set in impervious soil, a drainage pit 2 feet in diameter and 2 feet deep shall be excavated below each hydrant and filled completely with coarse gravel or broken stone mixed with coarse sand, under and around the bowl of the hydrant and to a level 6 inches above the waste opening. No hydrant drainage pit shall be connected to a sanitary sewer.
- E. Anchorage for Hydrant: The bowl of each hydrant shall be well braced against unexcavated earth at the end of the trench with stone slabs or concrete backing, or it shall be tied to the pipe with locked mechanical joint retainer glands or restrained joint pipe. In no case shall the waste opening be obstructed from free drainage.
- F. Cleaning: Hydrants shall be thoroughly cleaned of dirt or foreign matter before setting.



- G. Determination of Fire Hydrant Locations: Exact locations of fire hydrants shall be determined in the field to best suit field conditions. It is the intent to locate fire hydrants at property lines between lots.

#### 5.14 PLUGGING DEAD ENDS

Standard plugs shall be inserted into the bells of all dead ends of pipes, tees or crosses, and spigot ends shall be capped. Plugs or caps shall be jointed to the pipe or fittings in the appropriate manner.

#### 5.15 ANCHORAGE OF BENDS, TEES AND PLUGS

- A. Limiting Pipe Diameter and Degree of Bend: Reaction or thrust backing shall be applied on all pipelines 4 inches in diameter or larger at all tees, plugs, caps and at bend deflecting 22 ½ degrees or more movement shall be prevented by attaching mechanical joint retainer glands, rust proof tie rods, or other approved anchorage. Tie rods shall be coated with No-Oxide grease after installation.
- B. Material for Reaction Backing: Reaction or thrust backing shall be of concrete of a mix not leaner than 1 cement, 2 ½ sand, 5 stone, having compressive strength of not less than 2,000 psi. Backing shall be placed between solid ground and the fitting to be anchored. The minimum area of bearing on pipe and on ground shall be as shown on the plans. The backing shall be so placed that the pipe and fitting joint will be accessible for repairs.

#### 5.16 HYDROSTATIC TESTING

- A. General: After the pipe has been laid and backfilled as specified, all newly laid pipe with any and all services installed and connected, or any valved section of it shall, unless otherwise specified, be subject to hydrostatic testing, which shall include pressure testing and leakage testing. Hydrostatic testing shall conform to all requirements of the agency having jurisdiction. Hydrostatic testing shall also conform to the requirements of AWWA C600, unless otherwise specified herein. In general, the requirements of AWWA C600 will apply whether ductile iron or PVC pipe is used.
- B. Test Pressure: The test pressure shall be at least 150 psi and shall not exceed pipe, valve, or thrust restraint design pressures. The pressure shall not vary by more than  $\pm 5$  psi for the duration of the test.
- C. Pressurization: Each section of pipe shall be slowly filled with water and the specified test pressure, measured at the lowest point of elevation, shall be applied by means of a pump connected to the pipe in a satisfactory manner. Provide the pump, pipe connection, gauges, and all necessary apparatus.
- D. Air Removal: Before applying the specified test pressure, air shall be expelled completely from the pipe, valves, and hydrants, If permanent air release valves are not located at all high points, the Contractor shall install corporation stops at such points so that the air can be expelled as the line is filled with water. After all the air has been expelled, the corporation stops shall be closed and the test

pressure applied. After pressure testing, the corporation stops shall be removed and plugged.

- E. Duration of Pressure Test: The duration of each pressure test shall be until the line has been completely inspected for visible leaks, but in no case shall the pressure test duration be less than 6 hours.
- F. Recording Pressure Gauge: A recording pressure gauge shall be used during the pressure test. Charts shall be turned over to the Owner/Engineer.
- G. Examination: Any exposed pipe, fittings, valves, hydrants, and joints shall be examined by the Contractor carefully during the test. Any damage or defective pipe, fittings, valves, or hydrants that are discovered following the pressure test shall be repaired or replaced with sound material and the test shall be repeated until it is satisfactory to the Owner.
- H. Leakage Testing: Suitable means shall be provided for determining the quantity of water lost by leakage. No pipe installation will be accepted until or unless this leakage (evaluated on a pressure basis of 150 psi) is less than allowable leakage in the following formula:

$$L = \frac{SD(P)^{1/2}}{133200}$$

- L = allowable leakage in gallons per hour
- S = length of pipe tested, in feet
- P = average test pressure during the leakage test, in pounds per square inch gauge
- D = nominal diameter of the pipe in inches

- I. Leakage Defined: Leakage is defined as the quantity of water that must be supplied into the newly laid pipe, or any valved section of it, necessary to maintain pressure within 5 psi of the specified leakage test pressure after the pipe has been filled with water and the air expelled, for the duration of the leakage testing.
- J. Acceptance of Installation: No pipe installation will be accepted unless leakage is within the limits specified herein. If any test of pipe laid discloses leakage greater than that specified, it shall be repaired as necessary until the leakage is within the specified allowance.
- K. Visible Leaks: Repair all visible leaks regardless of the amount of leakage.
- L. Scheduling of Testing: The Owner/Engineer shall be notified prior to each testing. Pipe may be subjected to pressure testing and leakage testing at any convenient time after partial completion of backfill. Segments of water line not connected to existing water lines shall be chlorinated, flushed, and checked for absence of bacteria before the new section of line is pressure tested. The Contractor may at his option pressure test the line before chlorination, provided the new line is not connected to the existing line during the pressure test. This procedure is set forth to prevent contaminated water or water with high chlorine content from being forced into a line in service through a faulty valve or other device during pressure tests.

## 5.17 CHLORINATION OF COMPLETED PIPELINE

- A. Preliminary Flushing: Prior to chlorination, all dirt and foreign matter shall be removed by a thorough flushing through the hydrants, or by other approved means. Each valved section of newly laid pipe shall be flushed independently.
- B. Before placing into service, all new water distribution systems, or extensions to existing systems, or any valved section of such extension or any replacement in the existing water distribution system shall be disinfected in accordance with AWWA C651, latest edition.

Any of the following methods of procedure shall be followed, subject to the approval of the Owner/Engineer:

Liquid chlorine gas-water mixture  
Direct chlorine feed  
Calcium hypochlorite and water mixture

1. Liquid chlorine: A chlorine gas-water mixture shall be applied by means of a solution-fed chlorinating device, or, if approved by the Owner/Engineer, the gas shall be fed directly from a chlorine cylinder equipped with proper devices for regulating the rate of flow and the effective diffusion of gas within the pipe.

Point of application: The preferable point of application of the chlorinating agent shall be at the beginning of the pipeline extension, or any valved section of it, and through a corporation stop inserted in the horizontal axis of the newly laid pipe. The water injector for delivering the gas-water mixture into the pipe shall be supplied from a tap on the pressure side of the gate valve controlling the flow into the elevated tank, or the standpipe, or the reservoir, if available. If a supply of water is not available, haul the water by tank truck or other means. No additional payment will be made to the Contractor hauling water. All water used for testing or chlorinating shall be approved by the Owner/Engineer.

Rate of Application: Water from the existing distribution system or other source of supply shall be controlled to flow very slowly into the newly laid pipeline during the application of chlorine. The rate of chlorine gas-water mixture flow shall be in such proportions to the rate of water entering the pipe that the chlorine dose applied to the water entering the newly laid pipe shall be at least 40 to 50 ppm.

2. Calcium Hypochlorite or Chlorinated Lime in Water: On approval of the Owner, a mixture of either calcium hypochlorite or chlorinated lime of known chlorine content and water may be substituted as an alternative for liquid chlorine.
  - a. Calcium hypochlorite (comparable to commercial products known as "HTH", "Perchloron", and "Maxochlor"); or
  - b. Chlorinated lime (frequently called chloride of lime and known to industry as bleaching powder), may be used.

Proportions of Calcium Hypochlorite or Chlorinated Lime and Water Mixtures: A 5 percent solution shall be prepared, consisting of 5 percent of either powder to 95 percent of water by weight.

Rate of Application: The calcium hypochlorite or chlorinated lime and water mixture, first made into a paste and then thinned to a slurry, shall be injected or pumped into the newly laid pipe under conditions heretofore specified for liquid chlorine application, after preliminary flushing.

- C. Back Pressure Prevented: Back pressure, causing a reversal of flow in the pipe being treated, shall be prevented.
- D. Retention Period: Treated water shall be retained in the pipe long enough to destroy all non-spore-forming bacteria. This period shall be at least 24 hours and preferably longer as may be directed. After the chlorine treated water has been retained for the required time, the chlorine residual at pipe extremities and at other representative point shall be at least 25 ppm.
- E. Chlorinating Valves and Hydrants: In the process of chlorinating newly laid water pipe, all valves and other appurtenances shall be operated while the pipe is filled with the chlorinating agent.
- F. Final Flushing: Following chlorination, all treated water shall be thoroughly flushed from the newly laid pipeline. Discharge of chlorinated water shall conform to all local, state and federal regulations. Dechlorination shall be performed as required by regulatory agencies. Dechlorination shall be performed at the Contractor's expense.
- G. Bacteriological Tests: Samples shall be taken of water that has stood in the main for at least 16 hours after final flushing has been completed and shall be tested by a state certified laboratory for bacteriological quality in accordance with "Standard Methods for the Examination of Water and Wastewater". The samples shall show the absence of coliform organisms.

Samples shall be taken at locations selected by the Owner but not less than 1 samples shall be collected for every 7,000 feet of pipe or 1 sample from each dead-end line, whichever is greater. No hose or fire hydrant shall be used in collection of samples. A corporation cock shall be installed in the main with a copper tube gooseneck assembly for sampling.

If the initial disinfection fails to produce satisfactory bacteriological samples, the main shall be reflashed and shall be resampled. If check samples show the presence of coliform organisms, then the main shall be rechlorinated until tests show the absence of coliform organisms. There will be no additional cost to the Owner for subsequent chlorination and retesting. Copies of all bacteriological tests shall be furnished to the Owner/Engineer.

- H. Procedure When Cutting into Existing Pipelines: Cuts made in existing pipelines for the insertion of valves, fittings, repairs, or for any other purpose shall be

chlorinated by shaking a predetermined quantity of the powder into the pipe on each side of the cut-in. After slowly filling the section and reversing the flow, the chlorinated water shall be retained for several hours, then flushed until a residual chlorine of less than 4.0 mg/l has been attained.

- I. Resumption of Service: After satisfactory chlorination by any of these alternative procedures, the consumer may be served from the newly laid pipeline or the service may be resumed on existing pipelines after authorization is received from the health agency having jurisdiction.
- J. Procedure When Cutting Into Existing Pipelines: Cuts made in existing pipelines for the insertion of valves, fittings, repairs, or for any other purpose shall be chlorinated by shaking a predetermined quantity of the powder into the pipe on each side of the cut-in. After slowly filling the section and reversing the flow, the chlorinated water shall be retained for several hours, then flushed until no odor of chlorine can be detected in the wastewater, or preferably until a check has been made for residual chlorine as provided for herein.

#### 5.18 CONCRETE

The minimum compressive strength required at 28 days is 3,000 pounds per square inch. Field specimens and laboratory tests shall be made in accordance with the standards of the American society of Testing Materials. The minimum amount of water shall be used to produce a workable mix and shall not exceed 6 U.S. gallons per sack of cement. Slump shall range between 2 and 5 inches.

#### 5.19 EROSION AND PROPERTY CONTROL

Any existing sod or grass removed shall be replaced with new sod of the same type.

- A. Flow of Drains and Sewer Maintained: Adequate provisions shall be made for the flow of sewers, drains, and water courses encountered during construction and the lines and structures which may have been disturbed shall be immediately restored to their original condition at the expense of the Contractor.
- B. Property Protection: Trees, grass, fences, signboards, poles and all other property shall be protected unless their removal is authorized. Any property damage shall be satisfactorily restored by the Contractor at the expense of the Contractor.
- C. Erosion: The Contractor shall at all times take necessary precautions to prevent erosion or transportation of soil due to natural or induced water flows. Spoil banks and soil stockpiles shall be contained to prevent transportation of soil by run-off waters.
  - 1. Topsoil: As indicated on the plans or specifically required in the specifications, the final top surface (depth as specified) of soil within the specific area shall be a good quality topsoil which shall be material obtained from the striping operation and whatever additional topsoil required at the Contractor's cost from an off-site source. Topsoil shall be workable, friable, loamy soil free from hard lumps, stiff clay, gravel,

noxious weeds, brush and other deleterious materials. Lime shall be added to reduce the possibility of odor. Topsoil shall be placed in all areas disturbed by construction, prior to grassing. No direct payment will be made for topsoil unless specifically noted otherwise.

- a. Grading: The Contractor shall perform grading of every description regardless of the character of material encountered, within the limits and to the lines and grade shown on the plans. Slight changes in grades shown on the plans may be required to allow for final dressing and drainage as the work progresses. Sufficient topsoil shall be stockpiled for final dressing.
- b. Stripping: Stripping shall consist of the removal of a minimum of four inches of grass and topsoil from within the limits of the new construction as shown on the plans. Topsoil obtained from the stripping operation that meets or exceeds topsoil requirements of this section shall be stockpiled on the site in areas approved by the Owner. If any of the stripped material is not suitable for use as topsoil or embankment material, it shall be disposed of away from the construction site by the Contractor at no cost to the Owner.

2. Grassing and Mulching:

The trench lines and other areas disturbed by construction of water lines shall be grassed and mulched as hereinafter specified where indicated on the plans or where directed. These items are to be considered as special erosion control measures to be utilized only where specifically required and payment will be made only when these items are shown on the proposal or where Engineer authorization is granted. In all other areas, the provisions of paragraph entitled "Erosion and Property Control" of this section shall apply with respect to erosion control.

- a. General: After pipe trenches have been backfilled, the area to be grassed shall be graded to the final grade and roots, stumps, or other materials which might be harmful to grass growth shall be removed and disposed of. Care shall be taken to spread topsoil over the entire area to be grassed to the extent that topsoil along and adjacent to the trench lines is available.
- b. Fertilizer: After the surface has been prepared for grassing and before any grass or seeds are planted, the soil shall be loosened by harrowing or other approved methods, and the areas specified to be grassed shall be fertilized at a uniform rate of 1,500 pounds per acre with a standard commercial 8:8:8 fertilizer and 3,000 pounds of agricultural lime per acre.
- c. Seeding: The areas to be grassed shall be seeded with good sound seed in the following minimum quantities per acre:

Kentucky 31 Fescue    34pounds  
Common Bermuda    10 pounds

White Dutch Clover 10 pounds

In some areas, it may be necessary to vary the concentrations of various seed to suit local conditions and the Owner reserves the right to change proportions of the various seed so long as the total amount of seed does not exceed 74 pounds per acre at no change in contract price.

Seed shall be broadcast with hand operated equipment. When broadcast, seed shall be sown over the areas and raked or dragged and covered to the desired depth. Hydro seeding may, at the Contractor's option, be used in lieu of the above.

Unless specifically noted otherwise, Pensacola Bahia shall not be used.

- d. Mulching: In areas directed by the Owner, the surface of sprigged and overseeded slopes of the roadway or embankments shall be protected by the application of a mulch. The mulch shall be spread uniformly in a continuous blanket by hand or by suitable approved equipment, at a rate of two tons to the acre. Mulching material which, in the opinion of the Engineer, is too coarse or too short for proper securing in the surface soil will be rejected. Mulching shall be started at the windward side of relatively flat areas or at the upper part of a steep slope and continued uniformly over the entire area. The mulch material shall be anchored to the soil by spraying a light coating of emulsified asphalt over the straw or hay after these materials have been placed. The asphalt shall be applied by hand sprayers attached by hoses to an asphalt spreader or other approved methods. The asphalt adhesive shall be applied to the mulch at a rate of 150 gallons of undiluted (straight emulsion) asphalt per ton of straw or hay (300 gallons per acre). If the straight emulsion is further diluted with water in the ratio of 60 (straight emulsion) to 40 (water), the application rate shall be 250 gallons of asphalt emulsion per ton of straw or hay (500 gallons per acre). This will secure the mulch on the ground to form a soil binding mulch and prevent loss or bunching by wind or water.
- e. Maintenance: the Contractor shall maintain all grassed areas until acceptance of the entire contract and for a period of three months thereafter. Areas upon which an established stand of grass is not obtained, the Contractor shall reseed and remulch as hereinafter specified. A satisfactory stand of grass is defined as a cover of living grass in which gaps larger than 12 inches do not occur at the time of acceptance. Maintenance shall consist of watering, preserving, protecting, replacing dead grass, filling washes and generally maintaining the area until final acceptance.

If the grassing operation is accomplished after the month of August or before the month of March, in addition to the seeding as outlined above, the entire grassed areas shall also be over seeded with

Italian Rye Grass seed at the uniform rate of 40 pounds per acre at no additional cost to the Owner.

- f. Asphaltic Adhesive: Asphalt shall be a bituminous soil cover suitable for mulching of seeded areas and shall contain no petroleum solvents or other diluents which would be toxic to plant growth. It shall be a homogenous emulsification of especially refined petroleum asphalt suitable for spray application with or without dilution with water. Laykoid Soil Cover, manufactured by American Bitumuls and Asphalt Company, or other commercial types of asphalt specifically designed for mulching of seeded areas for erosion protection against rain or wind, will be acceptable. Cost of this item shall be included in unit price bid for grassing and mulching for erosion control.

- D. Erosion Control Netting: Erosion control netting shall be utilized in locations where specifically required by the engineer and installed in accordance with the manufacturers recommendation using 3/4 inch x 2 1/2 inch x 12 inch wedge shaped wooden stakes and/or staples. The netting material shall be Enkamat 7220 or engineer approved equal.

1. Construction Requirements: All surfaces to be protected shall be graded, fertilized, limed, and finished so as to be stable and firm.

Synthetic mat used as a ditch liner shall be applied with the length of roll laid parallel to the flow of the water. Where more than one width is required, a multi-width welded mat shall be supplied in multiples of 3 feet. All lap joints and upslope edges shall be staked at intervals of 3 feet or less. Where three-wide mat is required, lap joints to be limited to one every nine feet of width.

All wood stakes shall be driven to within 2 inches of the ground surface.

An anchor slot shall be placed at the upslope and downslope ends of the mat placement. At least 12 inches of the end of the mat shall be buried vertically in a slot dug in the soil. The mat shall be secured in the anchor slot by staples or stakes at intervals of 3 feet or less prior to burying, except when the ditch is located above the synthetic liner, in which case no stakes or staples shall be used in the anchor slot unless 6 inches separation is maintained between the point of the installed stake or staple, and the synthetic liner. The soil shall be firmly tamped against the mat in the slot.

Successive lengths of mat shall be overlapped at least 3 feet, with the upstream length on top. Stake or staple the overlap in 3 places evenly spaced across the end of each of the overlapping lengths and in 3 places across the width of the center of overlap area. Check slots shall be spaced so that a check slot occurs within each 20 feet. Stake or staple the mat in the check slot at each edge overlap and in the center of the mat, except when the ditch is located above the synthetic liner, in which case no stakes or staples shall be used in the check slot, unless 6 inches separation is maintained between the point of the installed stake or staple



and the synthetic liner. Beginning and terminal ends to be staked in accordance with installation manual.

Upslope edges of mat used as ditch lining shall terminate on 4-inch wide horizontal shelves running parallel to the axis of the ditch for the full length of the ditch. Edges of the mat shall be staked at 3-foot intervals, backfilled with soil, and tamped to original slope.

After the mat has been placed, the area shall be evenly seeded or sodded, as specified and where shown on the plans.

Synthetic liner damaged by the contractor during mat installation shall be repaired immediately.

The Contractor shall maintain the blanket until all work on the contract has been completed and accepted. Maintenance shall consist of the repair of areas where damaged by any cause.

2. Method of Measurement: Synthetic mat, including stakes and staples, complete in place and accepted, will be measured by the square yard of finished surface. Material placed outside the specified limits will not be measured or paid for and the contractor may be required to remove and dispose of the excess material without cost to the Owner.

## 5.20 BACKFILLING

- A. Backfilling: Backfill material shall be free from rocks or boulders and shall be deposited in the trench simultaneously on both sides of the pipe for the full width of the trench in four-inch (4") layers to an elevation of at least 6 inches above the top of the barrels of the pipe. Material shall be dry enough to compact to the equivalent density of the surrounding earth. If too dry the backfill material shall be dampened. Backfill containing broken pavement shall not be used. Backfill shall be in four-inch (4") layers, tamped with hand tamps, to 6 inches above the top of the pipe. The remainder of the trench shall be backfilled in six-inch (6") layers and tamped with a mechanical tamper specifically manufactured for compacting backfill.
- B. Deficiency of Backfill, by Whom Supplied: Any deficiency in the quantity of material for backfilling the trenches, or for filling depressions caused by settlement, shall be supplied by the Contractor at no cost to the Owner.
- C. Backfill Under Pavement: Backfill under all existing or proposed pavement for street, driveways, sidewalks, or roadways up to the existing grade or proposed grade, whichever is lower, and to a minimum distance of ten (10) feet adjacent to existing or proposed pavement, shall be as specified elsewhere herein.

## 5.21 MAINTENANCE OF SURFACES

Following the certification of completion by a registered professional engineer, the Contractor shall maintain the surface of the unpaved trenches, adjacent curb, sidewalks, gutters, shrubbery, fences, sod and other surfaces disturbed for a period of 3 months thereafter; and shall maintain the repaved areas (if paved by Contractor) and adjacent curbs, gutters, and sidewalks for two (2) years after said certification. All material and

labor required for the maintenance of the trenches and adjacent structures shall be supplied by the Contractor and the work shall be done in a manner satisfactory to the Owner.

#### 5.22 CLEAN-UP

The job shall be kept clean at all times. Loose dirt shall not be allowed to clog ditches or cover sidewalks. Soft clay or other undesirable material removed from the trenches shall be removed from the streets, sidewalks or ditches. The Owner reserves the right to demand that the Contractor's focus be diverted to this clean-up at any time.

#### 5.23 USE OF CHEMICALS

All chemicals used during project construction or furnished for project operation, whether herbicide, pesticide, disinfectant, polymer, reactant or of other classification, must show approval of either EPA or USDA. Use of all such chemicals and disposal of residues shall be in strict conformance with manufacturer's instructions.

#### 5.24 PERMITS, CERTIFICATES, LAWS AND ORDINANCES

The Contractor shall, at his own expense, procure all permits, certificates and licenses required of him by law for the execution of his work. He shall comply with all Federal, State, or Local laws, ordinances, or rules and regulations relating to the performance of the work.

#### 5.25 UNDERGROUND UTILITIES

The plans show certain features of topography, and certain underground utilities, but they do not purport to show in complete detail all such lines or obstructions. Such topography and notes on the plans were inserted from records available and are for the Contractor's convenience only and shall not be used as the basis for claims of extra compensation. Whenever necessary to determine the location of existing pipes, valves, or other underground structures, the Contractor shall examine all available records and shall make all explorations and excavations for such purpose. Any damage to existing facilities resulting from the Contractor's operations shall be immediately repaired by the Contractor at no cost to the Owner.

#### 5.26 SHOP DRAWINGS AND RECORD DRAWINGS

The Contractor shall submit to the Engineer for review and approval prior to ordering materials six (6) sets of shop drawings for valves, fittings, special connection fittings, and piping at connections to existing pipes. No separate compensation will be allowed the Contractor for Shop Drawings. Review and approval of Shop Drawings by the Engineer shall in no way relieve the Contractor of his responsibilities for materials and workmanship in construction of the project. Upon project completion, two (2) sets record drawings shall be submitted to the building inspector showing final construction conditions noting installed materials and locations.

To assure that manufacturers and suppliers are aware of the use to which their

equipment and products will be subjected, the Contractor shall require the manufacturer or manufacturer's representative to place the following certification on submittal data transmittals:

"This is to certify that we have examined the Plans and Specifications for this Project and have ascertained that this equipment or material is suitable for the purpose and use intended.

\_\_\_\_\_  
Authorized Signature"

5.27 ABANDONED WATER MAINS AND APPURTENANCES

The Owner shall retain ownership of all salvageable material removed from the project. The Contractor shall neatly store these materials at locations designated by the Engineer. The cost of removing and storing these materials as directed will be borne by the Contractor with no direct payment. Any material deemed unsalvageable by the Engineer or that is not wanted by the Owner shall become the property of the Contractor and removed from the work site for no additional compensation.

5.28 PRECONSTRUCTION PHOTOGRAPHS

Prior to start of clearing, grubbing, and excavation for water lines, a photograph shall be taken at 100 feet on centers by a commercial photographer using a wide-angle lens or of the entire project using a VHS video camera. The photograph(s) shall be taken along the centerline of the project looking up station and at least one station marker shall be visible in each photograph for identification purposes. Station markers shall be set by the Contractor. Each photograph shall be further identified on the back and video tapes shall be marked on the tape casing with project number, location, date and time of day that photograph was taken. One color print approximately 5" x 7" and the negative or one (1) color VHS video tape shall be delivered to the Engineer within one week after photograph is made. Additional supplemental photographs shall be required should areas requiring special attention be encountered. No direct payment will be made for photographic work.

5.29 PRESSURE TESTS AND CHLORINATION ADJACENT TO EXISTING WATER LINES

Sections of water lines adjacent to existing water lines that are in service shall be chlorinated, flushed and checked for absence of bacteria before the new section of line can be pressure tested. The line may be pressure tested prior to chlorination, provided the new line is not connected to the existing line during the pressure test. This procedure is set forth to prevent contaminated water or water with high chlorine content from being forced into a line in service through a faulty valve or other defect during pressure tests.

5.30 EXISTING WATER SYSTEM

All existing water lines and service connections shall be protected, maintained and kept in service during construction operations on the new water lines. Any existing lines cut or damaged shall be repaired immediately and the service restored on the existing lines.

5.31 DUST CONTROL

The Contractor shall at all times provide for the control of dust within residential areas and such other areas where dust is a nuisance to the public by sprinkling with water or by other approved dust control measures. Generally, water shall be provided by the Contractor at no direct cost to the Owner unless stated otherwise. Water provided by the Owner will only be available after prior agreement and through a meter.

5.32 PUBLIC SAFETY

All water line materials unloaded on the job sites shall be placed in areas well away from the traveling public in order to avoid hazardous conditions.

5.33 EXTRA DEPTH FOR WATER LINES:

Water lines shall be laid below existing drainage pipes, existing water lines, gas lines, and other utility lines, by deflecting pipe downward, unless otherwise shown on the plans. There will be no extra payment made for extra depth of waterline required to go under the existing drainage pipes and utilities.

5.34 TAPPING OF WATER MAINS

Tapping of existing water mains shall be performed by the Contractor where such taps are indicated on the plans or required for connection of new lines to existing lines. The Contractor shall furnish tapping valves and tapping sleeves (5.04 E and G) required for the tap. The Contractor shall perform all excavations, backfill, removing and replacing pavement and incidentals necessary for the tap. The Contractor shall notify the City and the Engineer of record a minimum of 24 hours prior to the work. The Contractor shall have the installation approved by both the City and the Engineer of record. The Contractor shall air test the installation prior to making the tap with a 100 PSI pressure test, with no drop in pressure for a minimum of 15 minutes. The City representative must be present for the installation, air test and tap. The Contractor shall provide the coupon from the tap to the City representative and the inspection sheet shall be completed in full. The City will not accept the work unless all stated conditions are met including, but not limited to, the inspection sheet. (Revised 3-15-2018)

Corporation stop outlets required for testing and chlorination of new water mains will be furnished and installed by the Contractor. The Contractor shall perform all excavation, backfill, removing and replacing pavement and incidentals necessary for installations of corporation stop outlets.

END OF SECTION

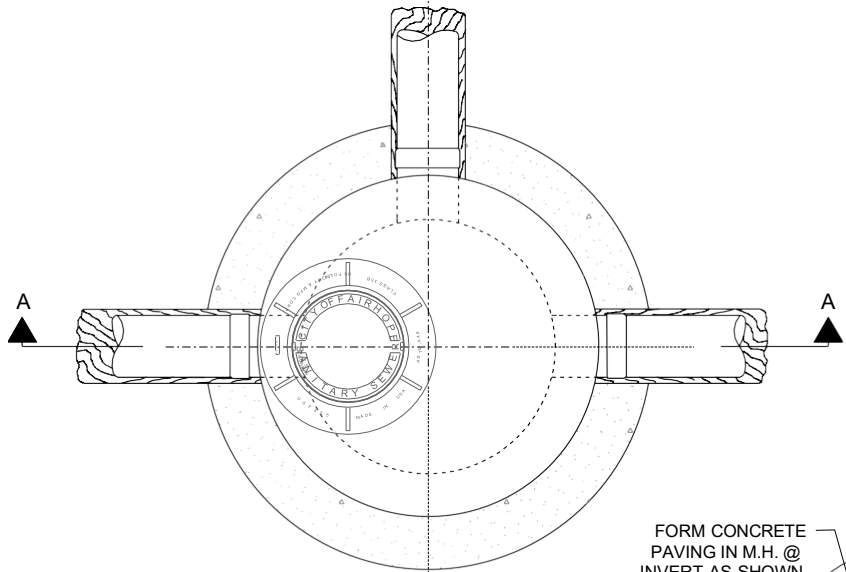

**PLAN**  
N.T.S.

- NOTES**
1. DISTANCE BETWEEN INVERT OF PIPE AND OUTSIDE OF BELL DETERMINES THE ELEVATION OF TOP OF 8" CONCRETE SLAB.
  2. MANHOLE STEPS SHALL BE STEEL RODS ENCASED IN POLYPROPYLENE PLASTIC AND SHALL BE TYPE "PS-1-B" AS MANUFACTURED BY M.A. INDUSTRIES, INC., OR AN APPROVED EQUAL.
  3. ALL PIPES IN OR OUT OF MANHOLE SHALL BE FLUSH WITH INSIDE WALL OF MANHOLE.
  4. FOR DEAD END MANHOLES THE FLOW CHANNEL SHALL EXTEND THE WIDTH OF THE MANHOLE.
  5. MANHOLES WITH A FORCE MAIN DISCHARGE SHALL BE LINED IN ACCORDANCE WITH SECTION 405 OF THE STANDARD SPECIFICATIONS.

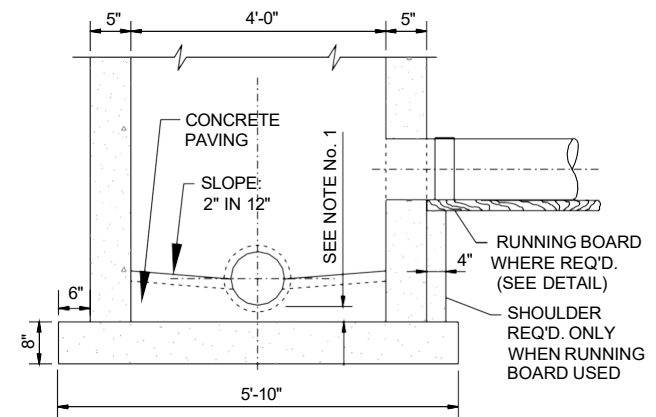

**SECTION C-C**  
N.T.S.

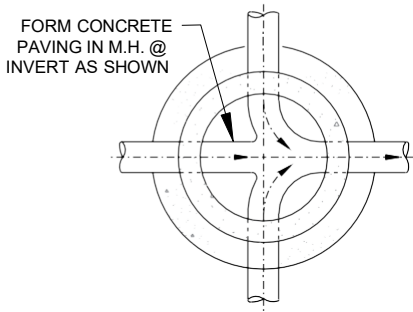

**MANHOLE WITH THREE OR MORE PIPES AT INVERT**  
N.T.S.

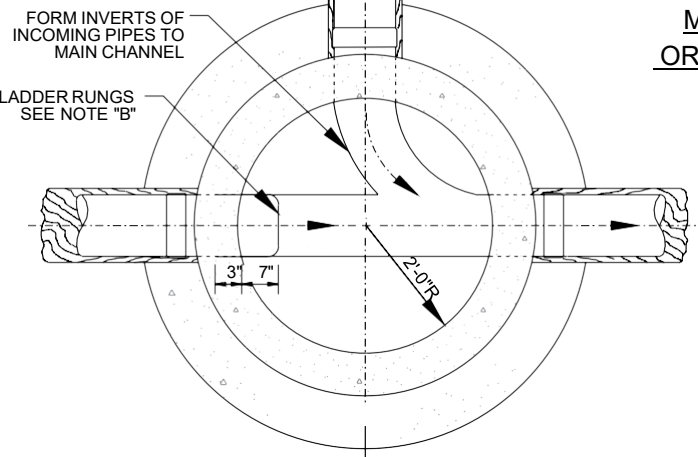

**SECTION B-B**  
N.T.S.

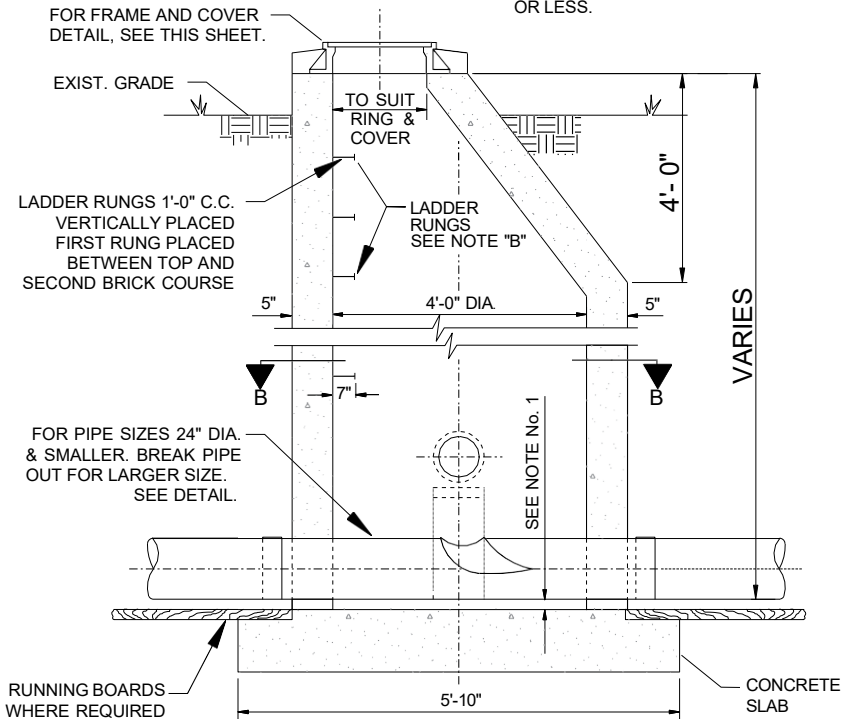

**SECTION A-A**  
N.T.S.

NOTE:  
ALL MANHOLES SHALL HAVE A FLAT TOP WHERE TOTAL DEPTH IS 4-FT OR LESS.

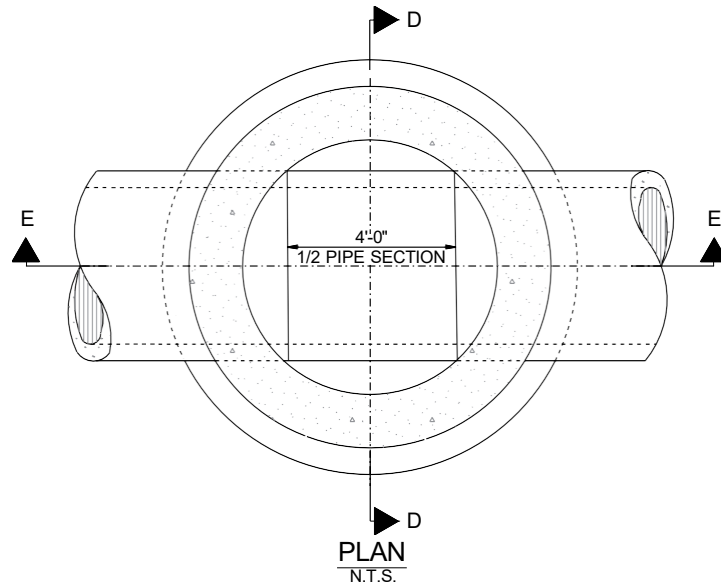

NOTE:  
DETAILS NOT SHOWN SHALL  
BE SAME AS FOR M.H. SIZE  
PIPE 24" DIA. & SMALLER

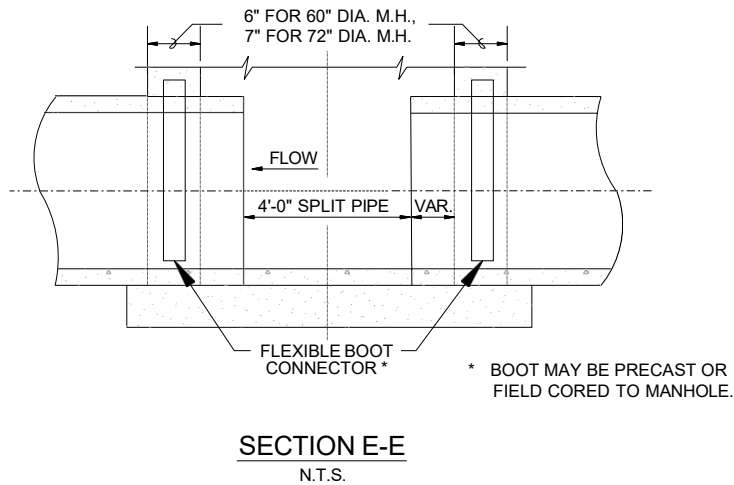

\* BOOT MAY BE PRECAST OR  
FIELD CORED TO MANHOLE.

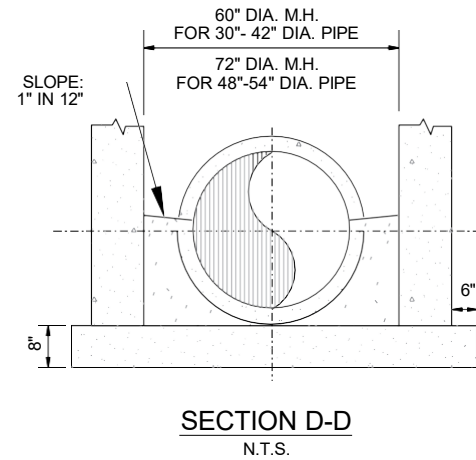

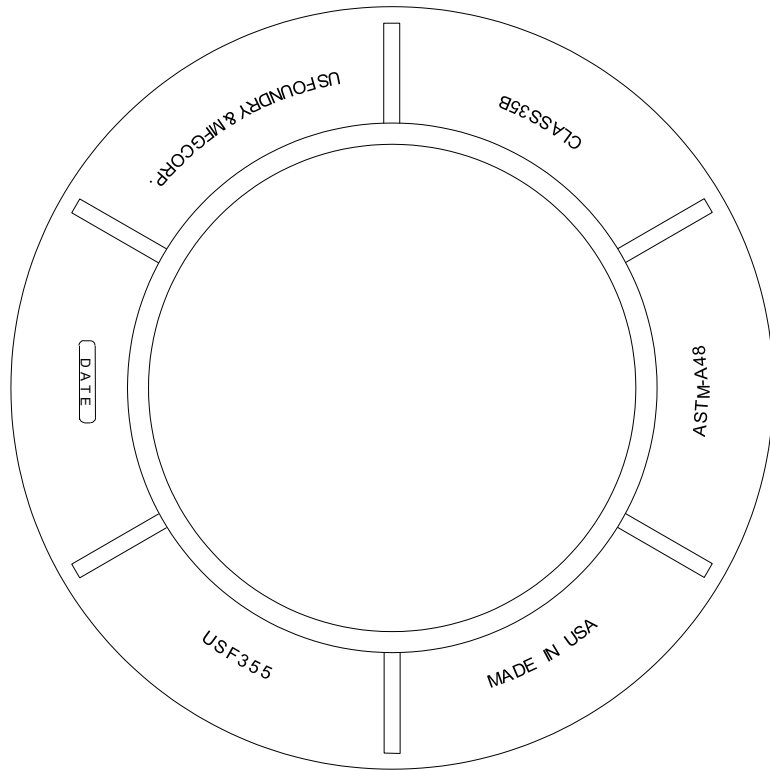

**RING TOP VIEW**  
N.T.S.

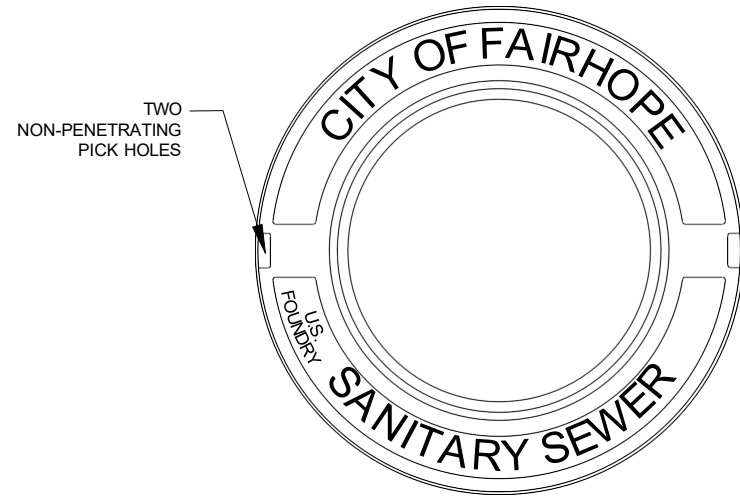

**COVER TOP VIEW**  
N.T.S.

**RANGE OF WEIGHTS**  
 FRAME - 230 LB (MIN) - 260 LB (MAX)  
 COVER - 118 LB (MIN) - 130 LB (MAX)  
 TOTAL - 348 LB (MIN) - 390 LB (MAX)

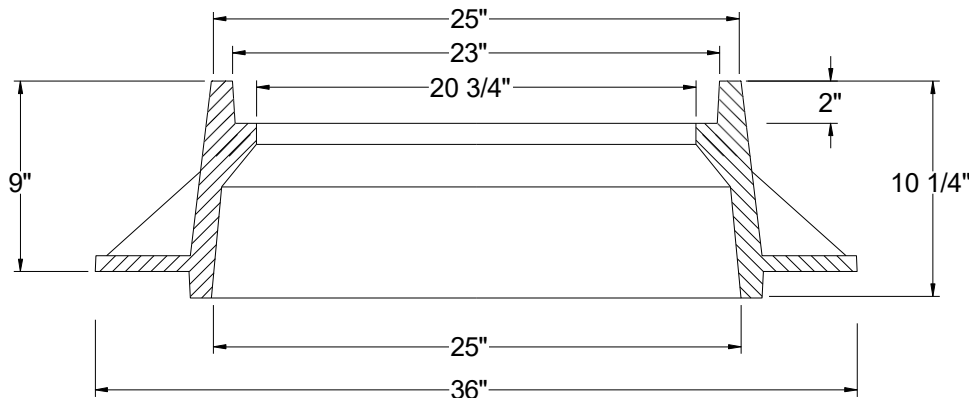

**RING SECTION VIEW**  
N.T.S.

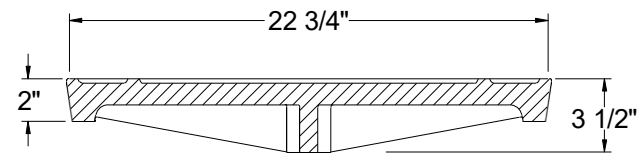

**COVER SECTION VIEW**  
N.T.S.

- NOTES:
1. MANHOLE RING AND COVER SHALL BE USF-355 WITH TYPE LB-PB COVER AS MANUFACTURED BY US FOUNDRY OR ENGINEER-APPROVED EQUAL.
  2. SHALL MEET ASTM-A48 GRAY IRON CLASS-35B.
  3. SHALL BE H-20 TRAFFIC RATED.

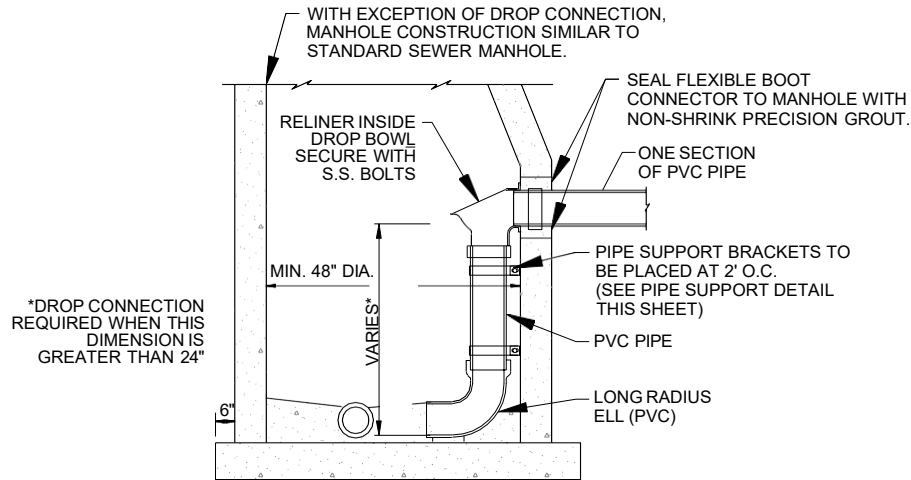

\*DROP CONNECTION REQUIRED WHEN THIS DIMENSION IS GREATER THAN 24"

**DETAIL OF DROP CONNECTION  
INSIDE OF MANHOLE**

N.T.S.

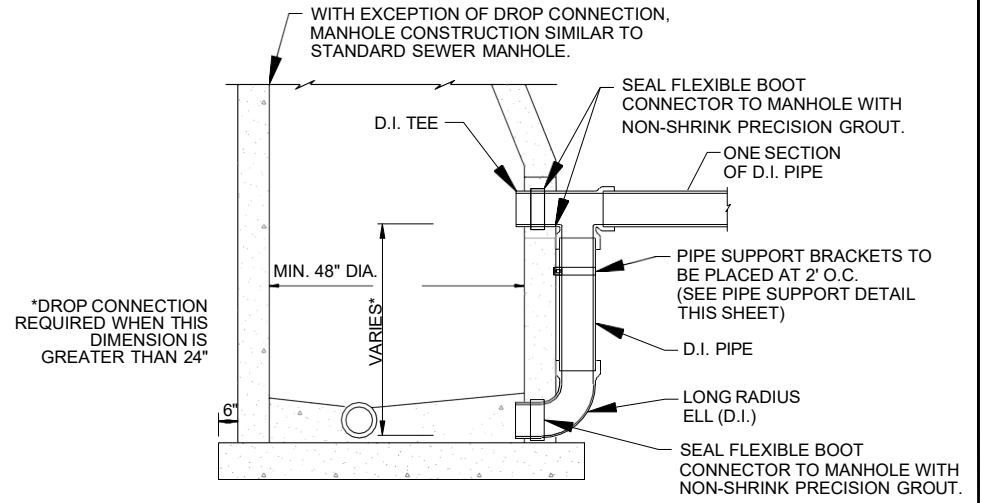

\*DROP CONNECTION REQUIRED WHEN THIS DIMENSION IS GREATER THAN 24"

**DETAIL OF DROP CONNECTION  
INSIDE OF MANHOLE**

N.T.S.

NOTE:  
INSIDE DROP CONNECTION IS PREFERRED. CONTRACTOR SHALL OBTAIN APPROVAL FOR OUTSIDE DROP CONNECTION FROM FAIRHOPE UTILITIES PRIOR TO CONSTRUCTION.

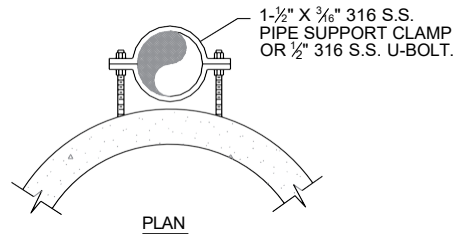

PLAN

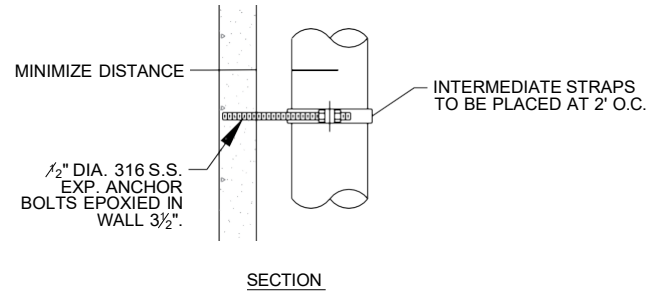

SECTION

**PIPE SUPPORT DETAILS**

N.T.S.



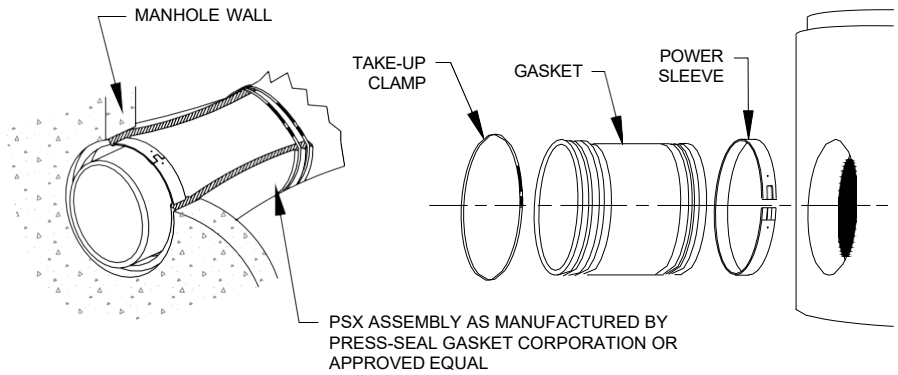

TYPICAL "BOOT" DETAIL  
N.T.S.

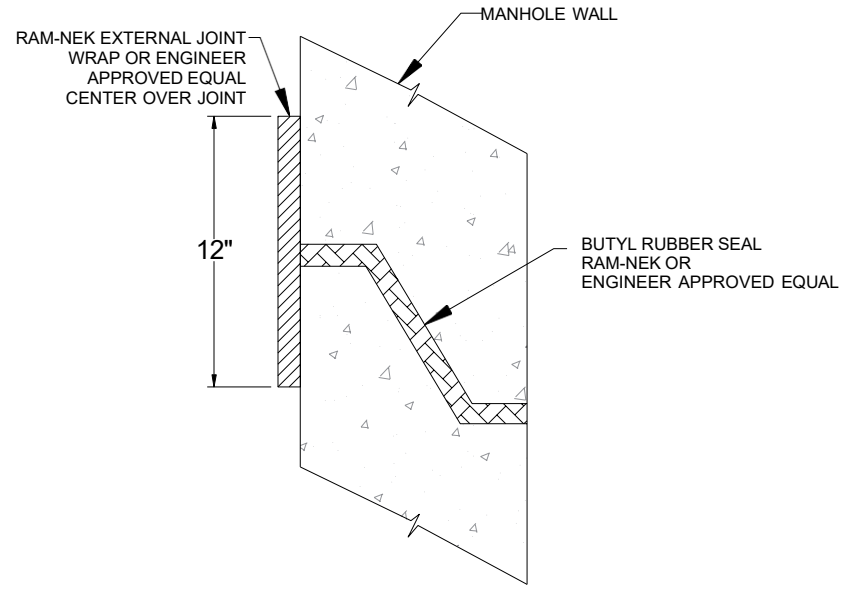

MANHOLE JOINT DETAIL  
N.T.S.

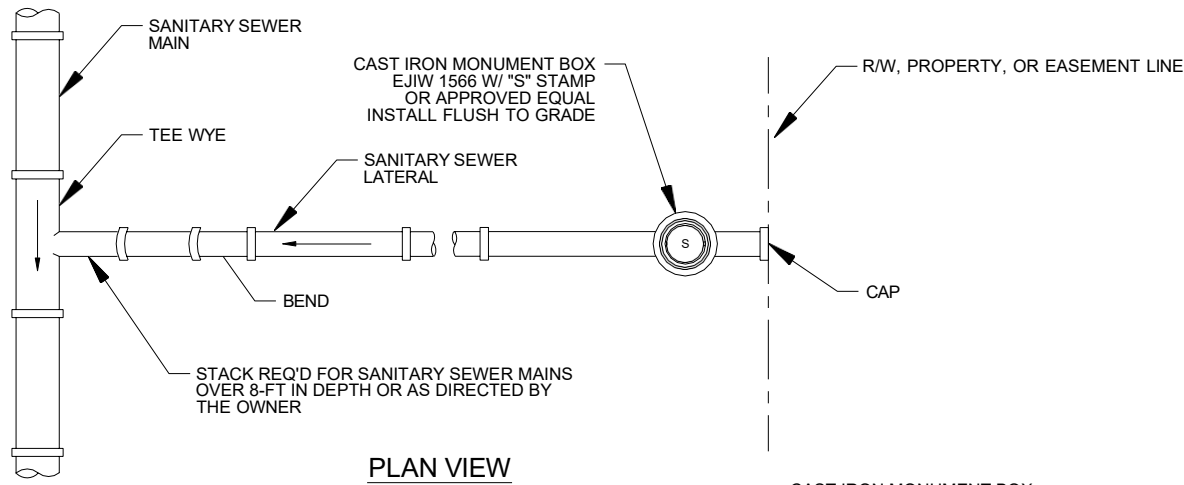

**PLAN VIEW**

N.T.S.

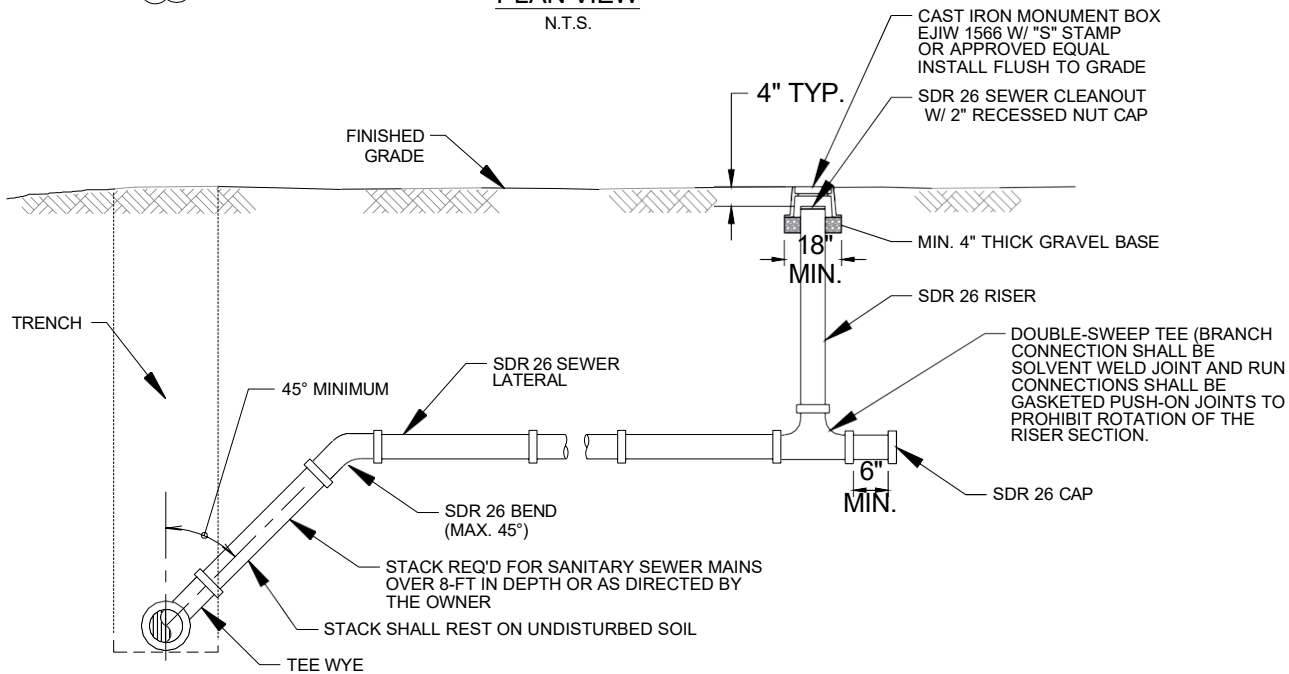

**ELEVATION VIEW**

N.T.S.

**NOTES:**

1. SANITARY SEWER LATERALS SHALL BE 4" SDR 26 UNLESS DIRECTED OTHERWISE BY THE OWNER.
2. DOUBLE SWEEP TEES SHALL HAVE SOLVENT WELD JOINTS FOR THE BRANCH CONNECTION AND GASKETED PUSH-ON JOINTS FOR THE RUN CONNECTIONS.
3. NON-SEIZE GREASE SUITABLE FOR USE WITH PVC FITTINGS SHALL BE APPLIED TO THE THREADS OF THE CLEANOUT CAP.
4. WHERE THE SANITARY SEWER MAIN IS PVC C900, THE TEE-WYE SHALL BE GASKETED C-900.
5. CLEANOUTS SHALL BE INSTALLED AS NEAR TO THE R/W, PROPERTY, OR EASEMENT LINE AS POSSIBLE. IF A CLEANOUT IS TO BE INSTALLED WHERE SIDEWALK IS EITHER EXISTING OR PROPOSED, IT SHALL BE PLACED BETWEEN THE SIDEWALK AND THE R/W LINE WHERE PRACTICAL. IF THE SIDEWALK IS INSTALLED AT THE R/W LINE, THE CLEANOUT SHALL BE PLACED BETWEEN THE SIDEWALK AND THE EDGE OF PAVEMENT IMMEDIATELY ADJACENT TO THE SIDEWALK. THE CLEANOUT SHALL NOT BE PLACED IN THE SIDEWALK OR A PAVED DRIVEWAY UNLESS APPROVED IN WRITING BY THE FAIRHOPE UTILITIES AND THE CITY OF FAIRHOPE.
6. NO HORIZONTAL BENDS SHALL BE ALLOWED BETWEEN THE MAIN AND THE CLEANOUT UNLESS APPROVED IN WRITING BY THE CITY OF FAIRHOPE. WHERE HORIZONTAL BENDS ARE ALLOWED, AN ADDITIONAL CLEANOUT SHALL BE INSTALLED AT EACH BEND.
7. PVC LATERALS SHALL BE MARKED WITH 14-GAUGE COATED COPPER WIRE BURIED 3 TO 6 INCHES ABOVE THE TOP OF THE PIPE IN ACCORDANCE WITH SECTION 400.07 OF FAIRHOPE UTILITIES' STANDARD SPECIFICATIONS. THE END OF THE LOCATE WIRE SHALL STUB-UP AT THE CLEANOUT INTO THE MONUMENT BOX.

NOTES:

1. THE SADDLE SHALL BE USED AS A TEMPLATE TO TRACE THE AREA OF CIPP LINER TO BE REMOVED.
2. A HOLE SAW WITH THE SAME DIAMETER AS THE SERVICE LATERAL SHALL BE USED TO CUT THE ACCESS HOLE IN THE CIPP LINER.
3. THE HOLE IN THE SADDLE SHALL BE PROPERLY ALIGNED WITH THE HOLE IN THE CIPP LINER.
4. THE EXCAVATION SHALL BE BACKFILLED IN ACCORDANCE WITH THE BOARD'S STANDARD SPECIFICATIONS.
5. FOR LATERAL REPLACEMENT OF EXISTING REMOTE CUT SERVICE CONNECTION, THE ABOVE NOTES AND DETAIL SHALL BE APPLIED.

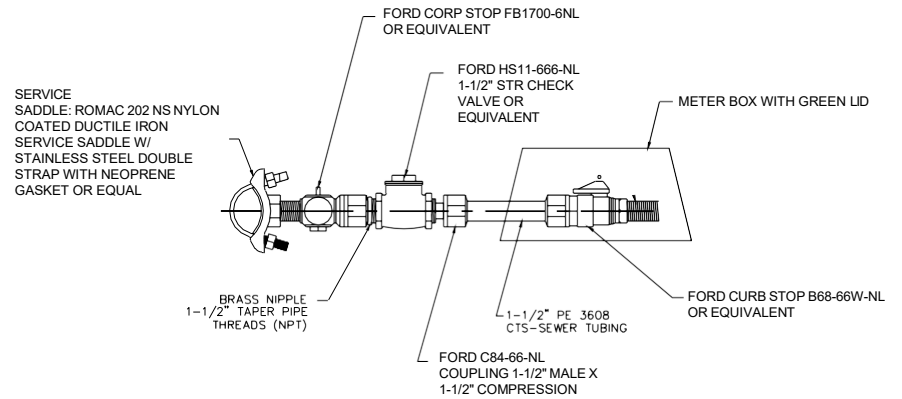

FAIRHOPE UTILITIES  
LOW PRESSURE SEWER SERVICE

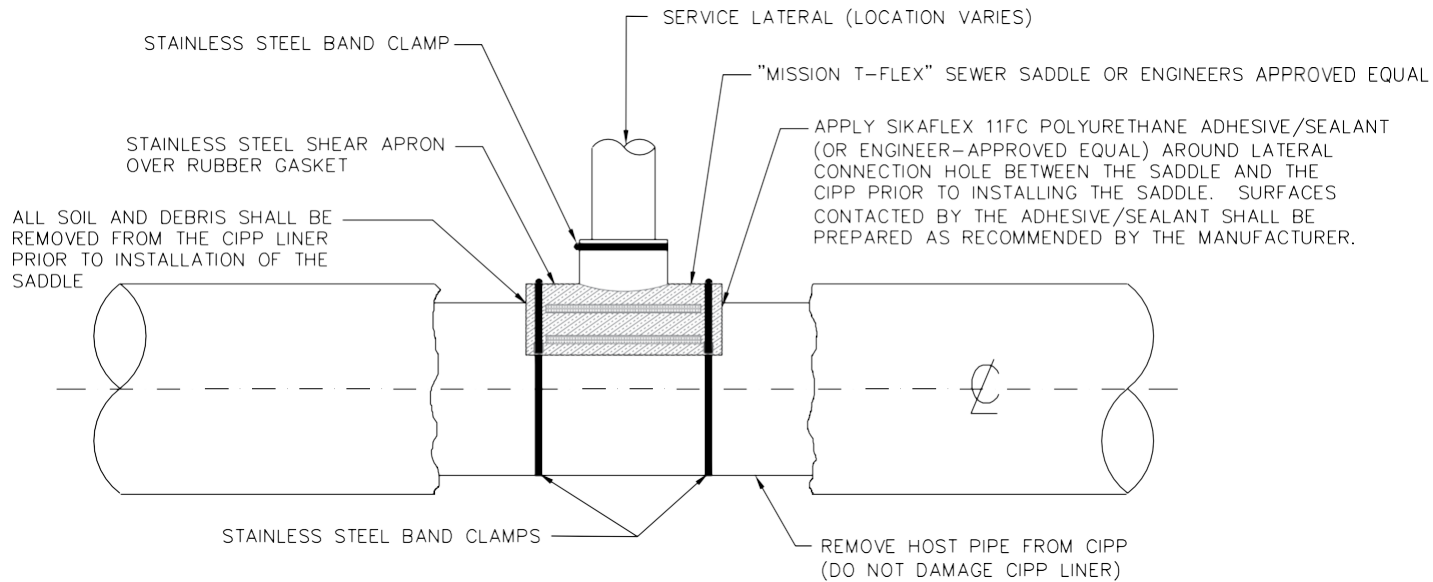

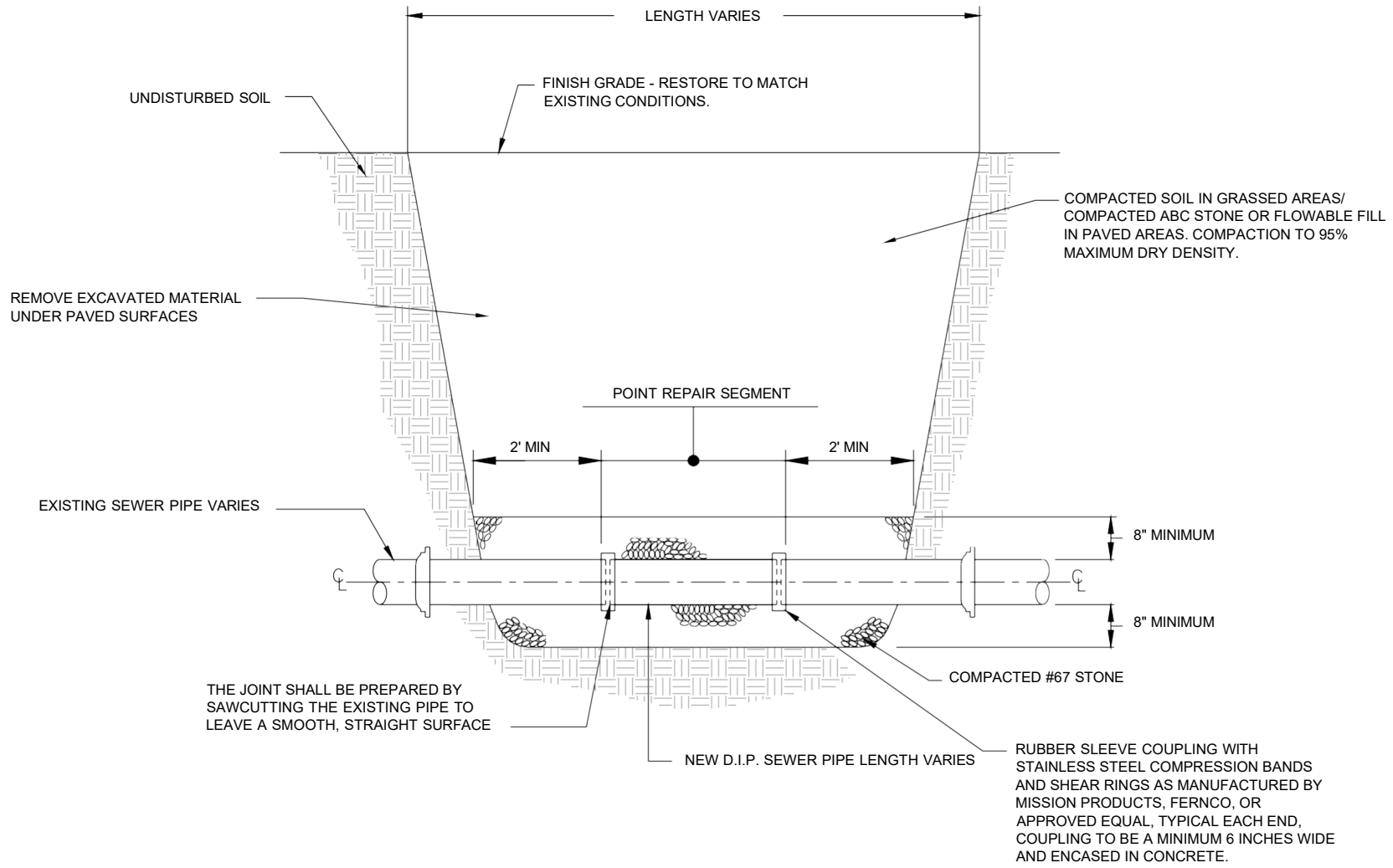

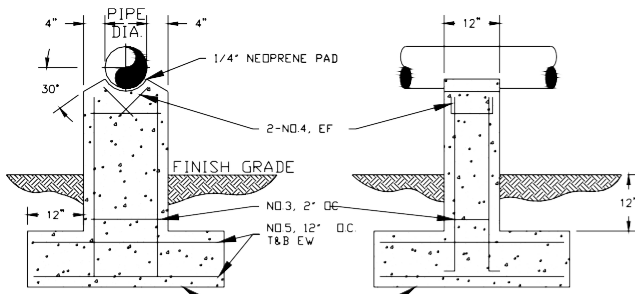

① PIPE SUPPORT  
DETAIL  
N.T.S.

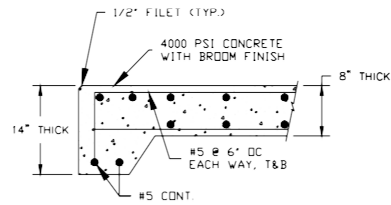

- OTHER DIMENSIONS TO BE DETERMINED BY GENERATOR SIZE  
- MINIMUM OF 1" CLEARANCE AROUND ALL SIDES OF GENERATOR AND/OR TRAILER.

② GENERATOR  
SLAB DETAIL  
N.T.S.

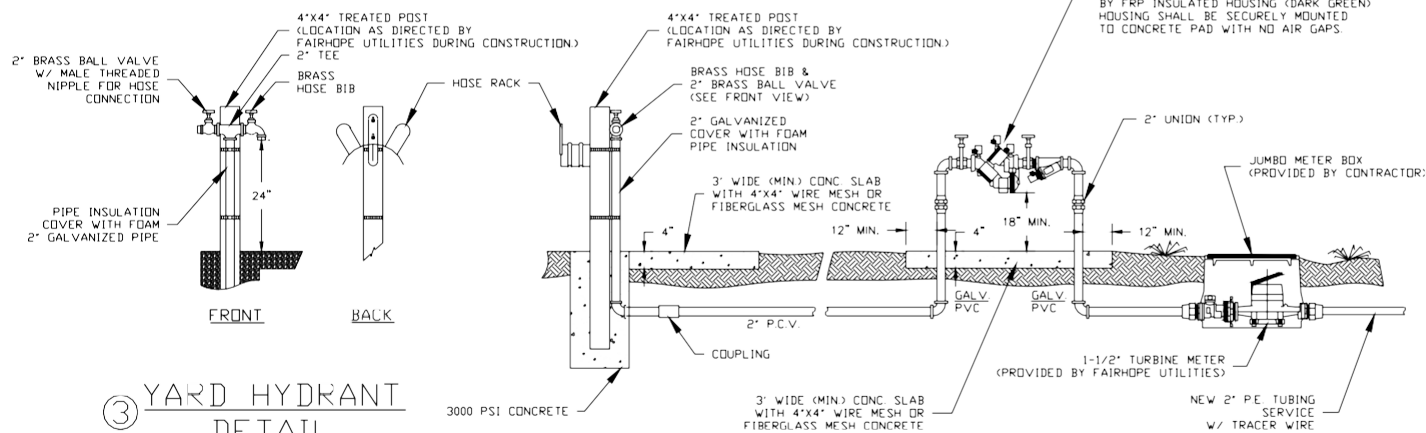

③ YARD HYDRANT  
DETAIL  
N.T.S.

④ LIFT STATION  
METER DETAIL  
N.T.S.

GENERAL LIFT STATION NOTES:

1. THE LOCATION OF INFLUENT LINES, WATER SUPPLY, ETC. ARE DRAWN OUT OF ORIENTATION ON SECTIONAL VIEW. SEE PLAN VIEW FOR ORIENTATION.
2. ALL PENETRATIONS IN WET WELL WALL FOR PIPING, ELECTRICAL, ETC. SHALL BE SEALED & SLEEVED.
3. TO PROTECT STANDPIPE FROM SWAY BRACE, EITHER WRAP PIPE WITH RUBBER SHEETING OR INSERT ALL U-BOLTS THROUGH RUBBER HOSE.
4. PIPING WITHIN THE WET WELL WALL SHALL BE FLANGED SCHEDULE 10 316 STAINLESS STEEL. INTERMEDIATE JOINTS SHALL BE WELDED. FITTINGS WITHIN THE WET WELL SHALL BE FLANGED 316 STAINLESS STEEL. ALL NUTS, BOLTS & ACCESSORIES WITH THE WET WELL SHALL BE 316 STAINLESS STEEL.
5. PIPE AND FITTINGS OUTSIDE OF WET WELL AND ABOVE GROUND SHALL BE 316 STAINLESS STEEL (FLANGED, SCHEDULE 10). ALL WELD-ON FLANGES SHALL BE 125# RFD SOCKET- WELD FLANGE OR RF WELD NECK FLANGE (TYPE). ALL BOLTS, WASHERS AND NUTS SHALL BE 316 STAINLESS STEEL AND SHALL BE COATED WITH "NEVER SEIZE" TYPE COATING.
6. THE ANNULAR SPACE BETWEEN TOP SLAB AND FORCE MAIN PIPE SHALL BE SEALED VIA LINK SEAL.
7. PROVIDE 4" PIPE (PVC, SCH. 80) THROUGH CONCRETE TOP WITH CAPPED TOP AND OPEN END BOTTOM. SEAL AROUND CONCRETE TOP WITH NON-SHRINK GROUT.
8. INTERIOR SURFACES OF FITTINGS INDICATED, INCLUDING THE FLANGE MATING SURFACES, AS WELL AS THE PUMP IMPELLER, VOLUTE, AND BACKPLATE SHALL BE COATED WITH BELZONA 1321 CERAMIC S-METAL. (UNLESS OTHERWISE SPECIFIED BY OWNER)
9. PLUG VALVES SHALL HAVE AN ALLOWABLE FLOW CAPACITY EQUAL TO 100% OF THE ADJACENT PIPE ARL, AND SHALL ALLOW "PIGGING".
10. THE INTERIOR OF ALL VALVES SHALL BE COATED.
11. CONTRACTOR SHALL PROVIDE 2-3/4" CONDUITS (ONE FOR POWER AND ONE FOR SIGNAL) FOR FLOW METER (IF REQUIRED). CONTRACTOR SHALL TERMINATE WIRES IN OWNER PROVIDED ELECTRICAL CONTROL CABINET.
12. EXHAUST OF ARV'S TO BE FIELD LOCATED. PROVIDE FITTINGS AS NECESSARY, AND PIPED TO WET WELL USING 2" 316 S.S. PIPE.
13. LOW LEVEL ALARM ELEV. TO BE SET IN COORDINATION WITH FAIRHOPE UTILITIES AND PUMP MANUFACTURER..
14. CONNECTION OF SWAY BRACE MOUNTING PLATE SHALL BE COORDINATED WITH PUMP MANUFACTURER.
15. A SECOND BRACE IS TO BE INSTALLED WHEN THE DEPTH OF WET WELL IS GREATER THAN 10' DEEP OR WHEN THE PUMPS ARE GREATER THAN 10HP.

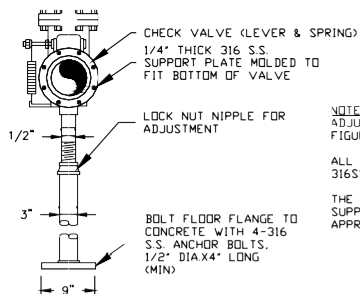

⑤ ADJUSTABLE PIPE STAND  
DETAIL  
N.T.S.

NOTES:  
ADJUSTABLE PIPE SUPPORT 'ANVIL' FIGURE 265" OR EQUAL  
ALL SUPPORT MATERIALS SHALL BE 316SS  
THE COMPONENTS OF THE VALVE SUPPORT SHALL BE ENLARGED AS APPROVED BY FAIRHOPE UTILITIES

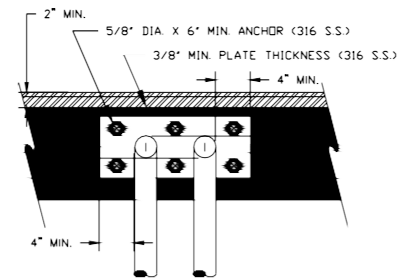

⑥ GUIDE RAIL  
N.T.S.

- REQUIRE SUBMITTAL FOR 'STYLE' OF RAIL ATTACHMENT.  
- PUMP RAILS TO BE 2" MIN. 316 S.S. WELDED TO PLATE IN A MANNER ACCEPTABLE TO FAIRHOPE UTILITIES.

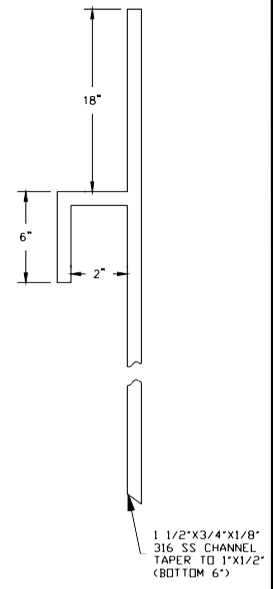
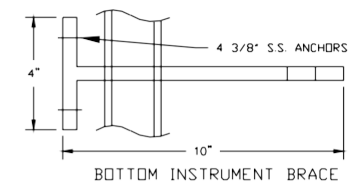
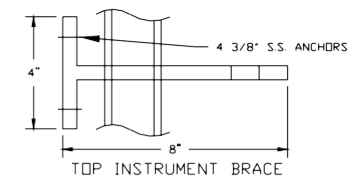
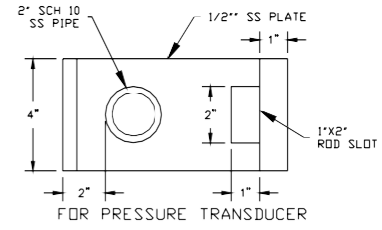

LEVEL  
⑦ INSTRUMENTATION SUPPORT  
N.T.S.

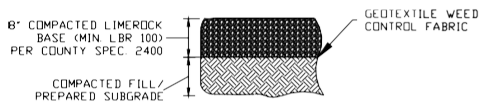

NOTES:  
1. ALL DEPTHS ARE COMPACTED DEPTHS.  
2. PREPARE SUBGRADE BY CLEANING AND GRUBBING, STRIPPING TOPSOIL AND PLACING GEOTEXTILE FABRIC.  
3. FILL FOR LIFT STATION SITE SHALL BE SAND MECHANICALLY COMPACTED TO 95% MODIFIED PROCTOR DENSITY IN MAXIMUM 12-INCH LIFTS LODGE MEASUREMENT TO ACHIEVE CORRECT GRADE.

⑧ LIFT STATION SITE  
DETAIL  
N.T.S.

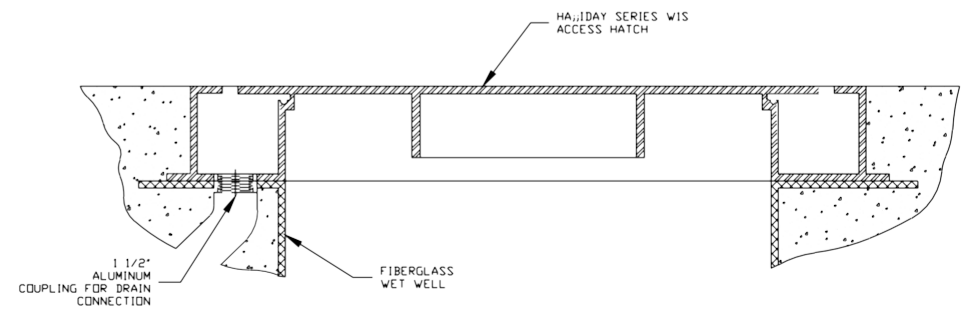

NOTES:  
- ALL ALUMINUM SURFACES IN CONTACT WITH CONCRETE SHALL BE COATED WITH A BITUMASTIC PAINT  
- HATCH DRAINS TO BE ROUTED TO OUTER EDGE OF TOP SLAB.

⑨ HATCH  
DETAIL  
N.T.S.

ALL WORK SHALL BE CONSTRUCTED IN ACCORDANCE WITH THE LATEST EDITION OF THE FAIRHOPE UTILITIES STANDARD SPECIFICATIONS

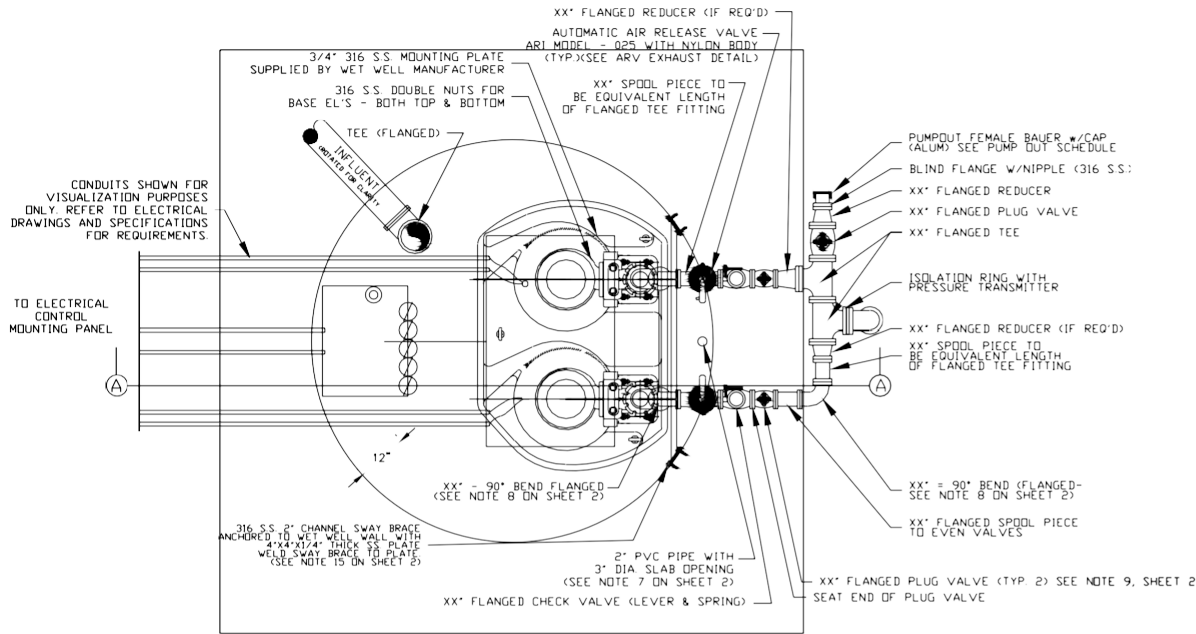

**PLAN VIEW**

NOTE: SEE CONC. COVER PLAN, COVER NOT SHOWN IN PLAN VIEW FOR CLARITY  
 N.T.S.

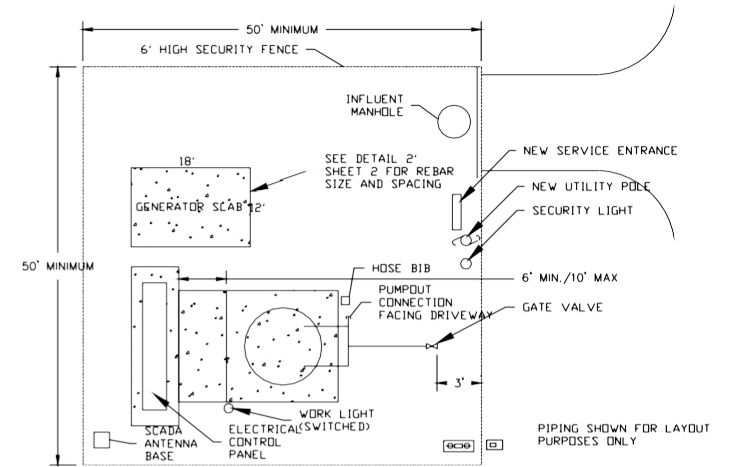

NOTE:  
 -6' HIGH FENCE (TO CONFORM WITH SURROUNDINGS) DIMENSIONS, CONFIGURATION & GATE, MAY VARY WITH EACH LOCATION, FAIRHOPE UTILITIES L/S PERSONNEL TO VERIFY LOCATION OF GATE PRIOR TO INSTALLATION  
 -STORMWATER FLOW SHALL BE DIRECTED AWAY FROM LIFT STATION SITE.  
 -ALL INFLUENT LINES TO LIFT STATION MUST BE ROUTED TO THE INFLUENT MANHOLE TO THE WET WELL, A SINGLE GRAVITY LINE SHALL CONNECT THE INFLUENT MANHOLE TO THE WET WELL, AT A DISTANCE OF NO GREATER THAN 30 FEET.  
 -IN-GRADE PULL BOXES SHALL BE LOCATED 10'-0" FROM WET WELL.  
 -PUMP OUT CONNECTION SHALL BE ORIENTED TO FACE DRIVEWAY.  
 -PROVIDE COMPACTED LIMEROCK BASE WITHIN PERIMETER FENCE PER DETAIL 7, SHEET 2.

**LIFT STATION  
 SITE PLAN**

N.T.S.

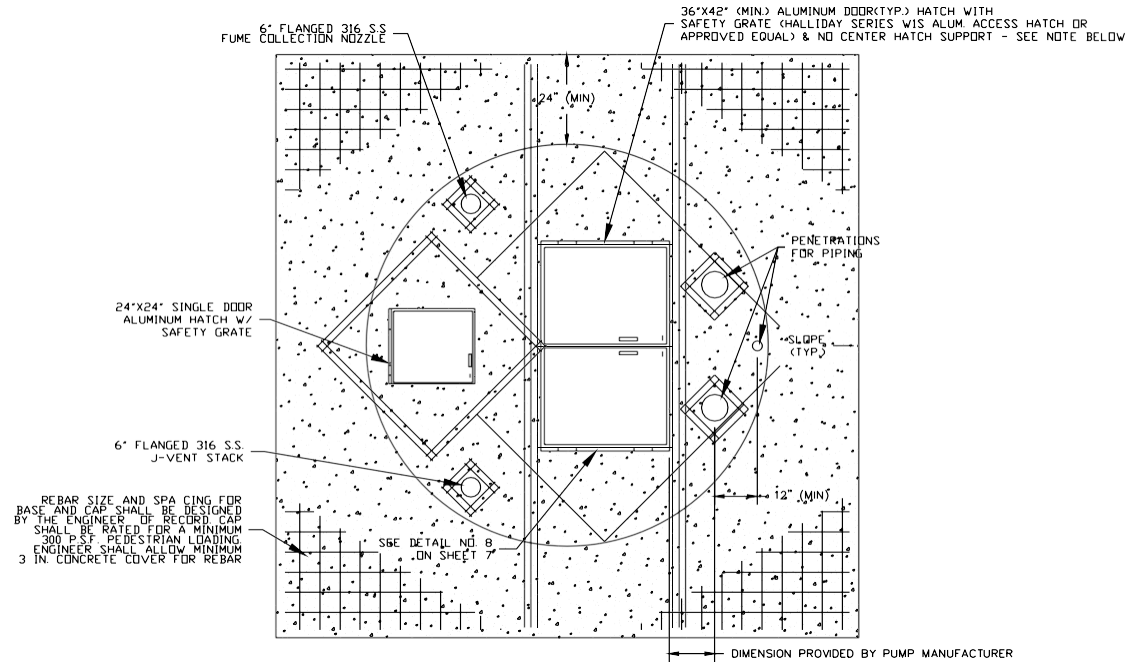
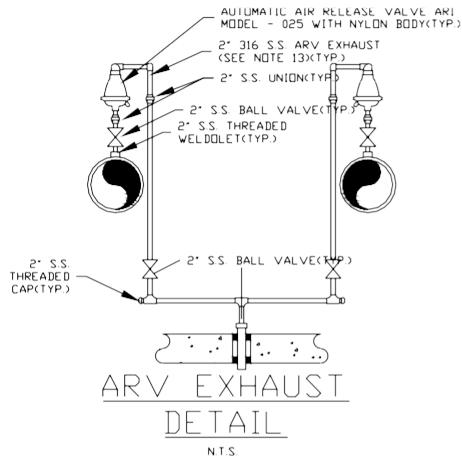

- NOTES:
- IT SHALL BE THE CONTRACTOR'S RESPONSIBILITY TO SELECT THE HATCH SIZE THAT WILL ENABLE THE PUMP(S) TO BE EASILY REMOVED FROM THE WET WELL THROUGH THE HATCH, SEE SPECIFICATIONS FOR CLEARING REQUIREMENTS.
  - HATCH SHALL BE HALLIDAY TYPE ALUM W/ST OR APPROVED EQUAL, FLUSH INSTALLATION, SINGLE COVER(S), 300 LB/SF LOADING, AND GASKETED TO BE RAIN TIGHT AND PROMOTE ODOR CONTROL.
  - SAFETY GRATE(S) SHALL BE HINGED ON SAME SIDE AS HATCH.
  - HEAVIER DESIGN LOADS MAY BE REQUIRED.



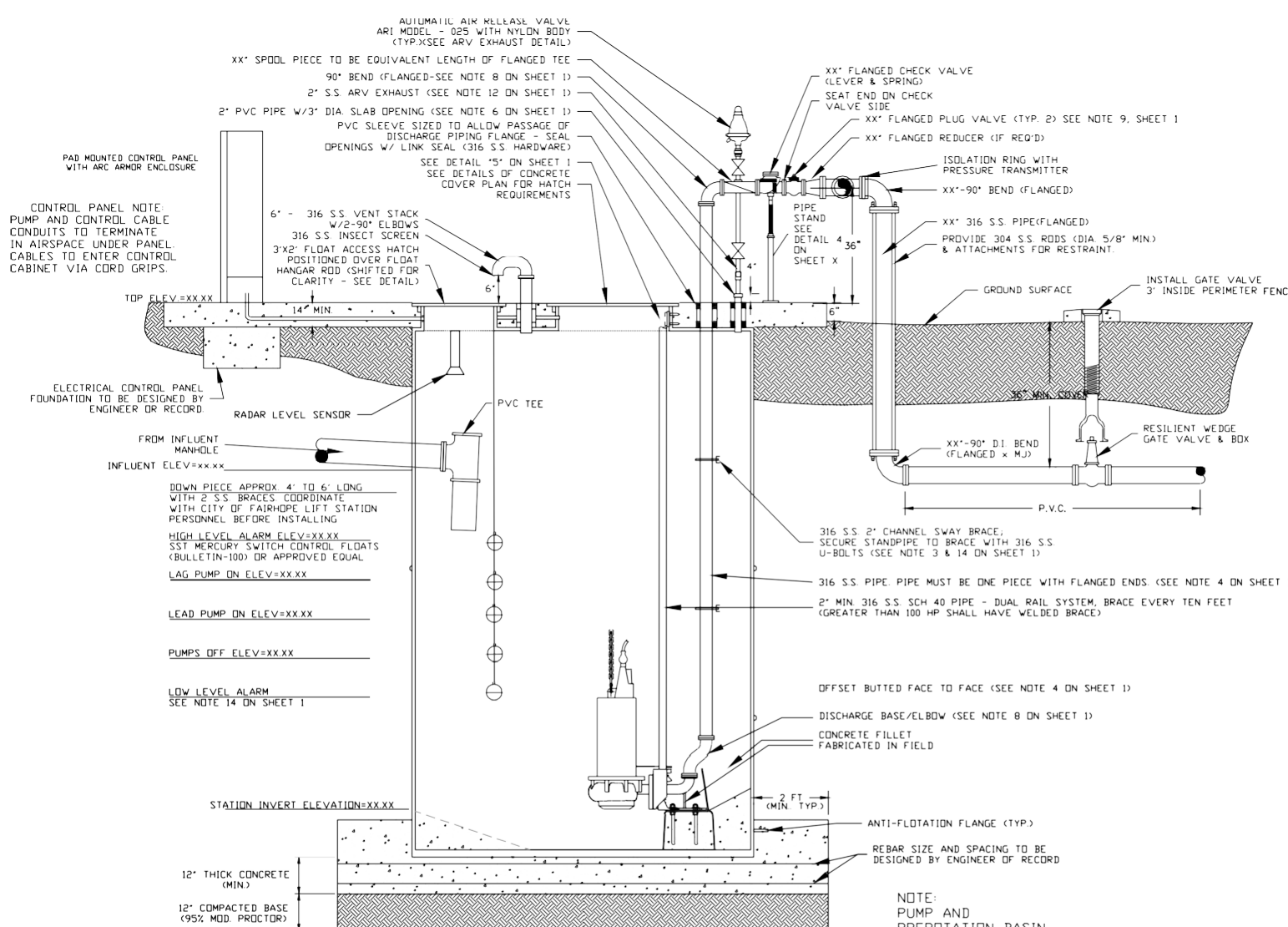

**CROSS SECTION AA**  
N.T.S.

XX - VALUES TO BE PROVIDED BY ENGINEER

PUMP OUT SCHEDULE	
DISCHARGE	
4	4
6	6
8	8
10	8
12+ LARGER	*

\* COORDINATE WITH FAIRHOPE UTILITIES

PUMP INFORMATION	
MANUFACTURER	XXX
TYPE PUMP	XXX
MODEL NO	XXX
PUMP DESIGN POINT (GPM @ TDH)	XX GPM @ XX TDH
IMPELLER SIZE & NO	XXX
DISCHARGE PIPE SIZE	4"
MAX MOTOR HP	XXX
MAX SPEED	XXX
MIN EFF @ DESIGN POINT	XXX
VOLT/PHASE	XXX

PUMP DISCHARGE SHALL BE CENTERLINE ONLY, NO TANGENTIAL DISCHARGE ALLOWED.

WET WELL INFORMATION	
WET WELL DIAMETER	8" MIN
WET WELL DEPTH	XXX"
INFLUENT DIA - ELEV	X'@XX.XX'
FORCE MAIN DIA - ELEV	4" @ XXX.XX'(TDH)
INVERT ELEV OF STATION	XXX.X'
PUMPS OFF ELEV	XXX.X'
HIGH LEVEL ALARM ELEV.	XXX.X'
TOP ELEV OF STATION	XXX.X'

CONTROL PANEL NOTE:  
PUMP AND CONTROL CABLE CONDUITS TO TERMINATE IN AIRSPACE UNDER PANEL. CABLES TO ENTER CONTROL CABINET VIA CORD GRIPS.

- DOWN PIECE APPROX 4' TO 6' LONG WITH 2 S.S. BRACES COORDINATE WITH CITY OF FAIRHOPE LIFT STATION PERSONNEL BEFORE INSTALLING
- HIGH LEVEL ALARM ELEV=XX.XX
- SST MERCURY SWITCH CONTROL FLOATS (BULLETIN-100) OR APPROVED EQUAL
- LAG PUMP ON ELEV=XX.XX
- LEAD PUMP ON ELEV=XX.XX
- PUMPS OFF ELEV=XX.XX
- LOW LEVEL ALARM SEE NOTE 14 ON SHEET 1

NOTE:  
PUMP AND PREROTATION BASIN ENLARGED TO SHOW DETAIL. DISCHARGE PIPE SIZE AND BASE ELBOW SHALL BE AS PER ENGINEER'S RECOMMENDATION.



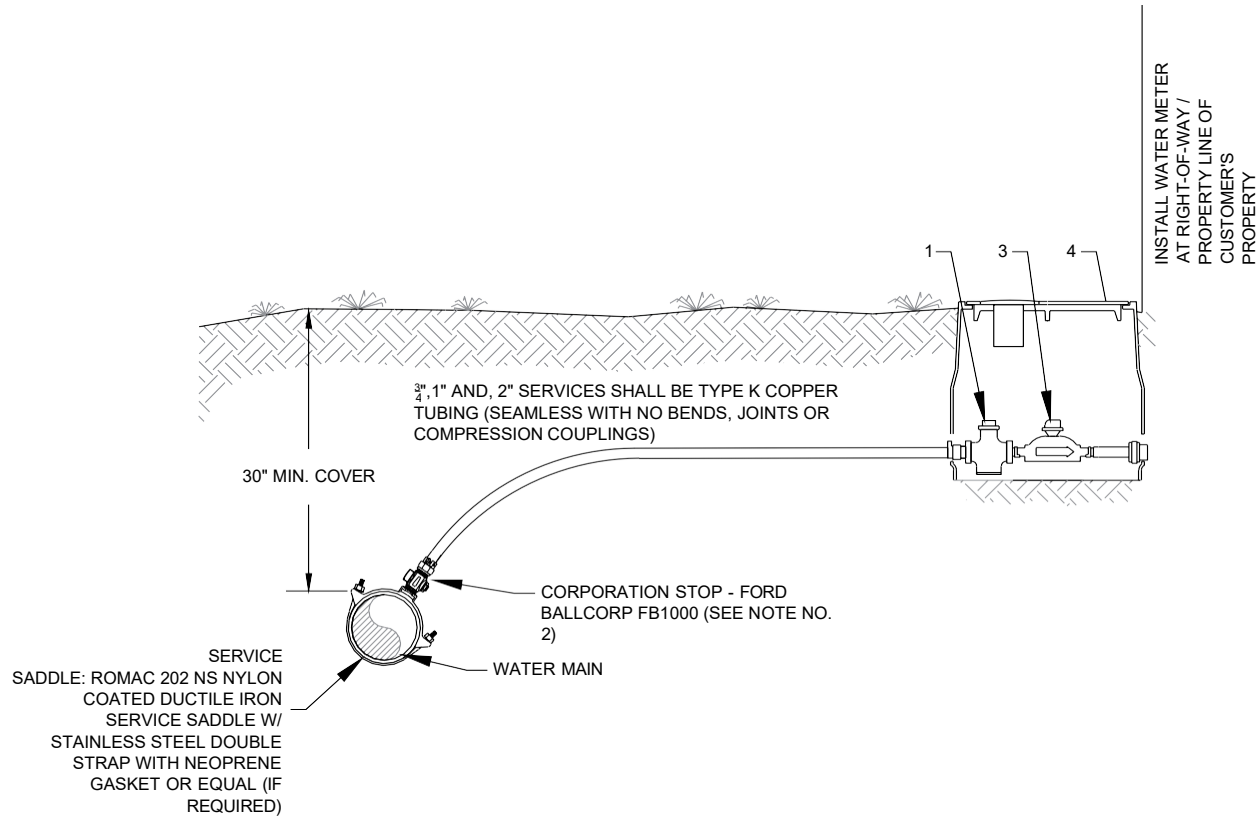

ELEVATION VIEW  
N.T.S.

WATER METER MATERIAL SCHEDULE

1. CURB STOPS SHALL BE DESIGNED FOR MINIMUM PRESSURE OF 175 PSI AND SUITABLE FOR SERVICE PIPING AND SHALL BE FORD B43-332 RGW-NL OR EQUIVALENT. CURB STOP SHALL HAVE PADLOCK WING AND "365" DEGREE VALVE OPERATION WITH NO STOPS.
2. CORPORATION STOPS WHERE REQUIRED OR DIRECTED, SHALL HAVE STANDARD CC CORPORATION STOP THREAD ON INLET AS SPECIFIED BY AWWA C800, AND COPPER TUBING SIZE O.D. OUTLET SUITABLE FOR SERVICE PIPING. CORPORATION STOPS SHALL BE FORD BALLCORP FB-1000 SERIES WITH GRIP NUT OR APPROVED EQUIVALENT. CORPORATION STOPS SHALL BE TAPPED INTO WATER MAINS ONLY BY MEANS OF A SERVICE SADDLE.
3. WATER METERS WILL MEET OR EXCEED THE REQUIREMENTS OF AWWA SPECIFICATION C700, LATEST REVISION, AND AN AFFIDAVIT OF COMPLIANCE AND CERTIFICATE OF TESTING FOR ACCURACY WILL BE FURNISHED. METERS MAY BE EITHER NUTATING DISC, POSITIVE DISPLACEMENT, OR OSCILLATING PISTON. FROST PROTECTION WILL NOT BE REQUIRED. REGISTERS SHALL BE HERMETICALLY SEALED, MAGNETIC DRIVE, WITH STRAIGHT READING IN U.S. GALLONS. SERIAL NUMBER WILL BE IMPRINTED ON THE CASE AS WELL AS ON THE REGISTER BOX LID. MATERIALS USED FOR METERS SHALL BE AS SPECIFIED IN AWWA SPECIFICATION C700.
4. METER BOX AND COVER
  - A. BOXES WILL BE PLASTIC WITH IRON READER LIDS OR CONCRETE WITH CAST IRON LIDS. BOXES WILL BE SUFFICIENT SIZE TO HOUSE THE METER AND CURB STOP.