

**CITY OF FAIRHOPE  
COVER SHEET**

The following is related to damages caused by Hurricane Sally  
(FEMA 4563) on or about September 15, 2020.

**BID 030-21 Covered Slip Roof and Framing Repairs at Docks (FEMA 4563)**

**COF Project # PW012-21 Covered Slip Roof repairs at Docks**

**Date Issued:** July 15, 2021

**Deadline to Submit:** **Tuesday, August 3, 2021, 1:00 p.m.**

**Direct all Questions To:** Dee Dee Brandt, Purchasing Manager  
[DeeDee.Brandt@fairhopeal.gov](mailto:DeeDee.Brandt@fairhopeal.gov)

**Submitted Bid Should Include:** Authorized signatures including notaries  
--Completed BID Response Form  
If issued,-- signed Addenda,  
--Completed Contractor Information sheet.  
--Anti-Lobbying Certification  
--Other supporting documentation as requested

**Deliver BIDS To:** Dee Dee Brandt, Purchasing Manager  
[DeeDee.Brandt@fairhopeal.gov](mailto:DeeDee.Brandt@fairhopeal.gov)  
Public Works Building  
555 S. Section Street  
Fairhope, AL 36532

**BID RESPONSE FORM AND SPECIFICATIONS  
SAMPLE CONTRACT DOCUMENTS**

**BID 030-21  
Covered Slip Roof and Framing Repairs at the Docks  
(FEMA 4563)**

**COF Project No PW012-21**

**Public Works Department**

**City of Fairhope, AL**

**Sherry Sullivan, Mayor**

**Jack Burrell, Council President**

Set No. \_\_\_\_\_

## ADVERTISEMENT

**Sealed Bids** will be received by the City of Fairhope in Baldwin County, Alabama, in the City of Fairhope offices, 555 South Section St. Fairhope, Alabama, until **Tuesday, August 3, 2021, at 1:00 p.m.** and then publicly opened thereafter, for furnishing all labor and materials, and performing all work required by the City of Fairhope and described as follows:

### **BID 030-21 Covered Slip Roof and Framing Repairs at the Docks —FEMA 4563**

The City of Fairhope is requesting responses to repair and replace portions of galvalume roof and wood structure/sheathing on the Covered Slips Pavilion at Fairhope Docks located at 848 Sea Cliff Drive, Fairhope, Alabama. During Hurricane Sally, September 16, 2020, this mono-sloped pile and braced roof system was damaged. Damage includes loss of R-panels, broken/racked bracing and loss of end-wall fascia sheathing

BID documents may be viewed and downloaded on the City of Fairhope website at [www.fairhopeal.gov](http://www.fairhopeal.gov) or by e-mailing: Dee Dee Brandt, Purchasing Manager at [DeeDee.Brandt@fairhopeal.gov](mailto:DeeDee.Brandt@fairhopeal.gov) or Cory Pierce at [cory.pierce@fairhopeal.gov](mailto:cory.pierce@fairhopeal.gov). Specifications are on file and may be seen in the Purchasing Department of the City of Fairhope, Alabama, 555 S. Section Street.

Questions or comments pertaining to this must be presented in writing as e-mail to the attention of the Purchasing Manager, Dee Dee Brandt, [DeeDee.Brandt@fairhopeal.gov](mailto:DeeDee.Brandt@fairhopeal.gov) Seventy-Two (72) hours prior to the Quote opening or will be forever waived.

All BIDs must be on the Bid Response forms provided in the Bid Documents. Bids will be received addressed to Dee Dee Brandt, Purchasing Manager, at the Public Works Building located at 555 S. Section St., Fairhope, AL, by **1:00 p.m. Wednesday, August 3, 2021**. Bids shall be accompanied by a BID SECURITY equal to 5% (percent) of the bid price, but in no event more than \$10,000.00. BID SECURITY shall be in the form of a Bid Bond signed by a Bonding company authorized to do business in the State of Alabama, or a Cashier's Check payable to the City of Fairhope.

**THERE WILL BE A NON-MANDATORY PREBID MEETING AT: 10:00 AM on July 27, 2021.**, at the City offices located at the Public Services and Utilities Building, 555 S. Section Street, Fairhope, AL.

The City of Fairhope is an Equal Opportunity Employer and requires that all **CONTRACTORS** comply with the Equal Employment Opportunity laws and the provisions of the **CONTRACT** Documents in this regard. The **CITY** also encourages and supports the utilization of Minority Business Enterprises on this and all public Bids. Failure to observe the instructions contained herein will constitute grounds for rejection of your Bid. The City reserves the right to accept or reject all Bids or any portion thereof, and to waive informalities and to furnish any item of material or work to change the amount of the **CONTRACT**, whichever is in the best interest of the City of Fairhope.

The **CONTRACTOR** must furnish to the City of Fairhope at the time of the signing of the CONTRACT a certificate of insurance coverage as provided in the **CONTRACT** documents which will include comprehensive insurance, **CONTRACTOR** Automobile Liability Insurance, and where applicable, **CITY'S** Protective Liability insurance, **SUB- CONTRACTOR'S** public liability and property damage insurance. The company that is awarded the **BID** must have Workman's Compensation Insurance on all of its employees if work is to be performed on City of Fairhope premises. General Liability Insurance, specifying coverage, must be maintained to hold the City of Fairhope harmless in the event of an accident. See **BID** packet for details.

No **BIDS** will be considered unless the **CONTRACTOR**, whether resident or non-resident of Alabama, is properly qualified to submit a proposal for this type of work in accordance with all applicable laws of the State of Alabama. Where applicable, this shall include evidence of holding a current license from the State Licensing board for General Contractors, Montgomery, Alabama, as required by Chapter 8 of Title 34, of the Code of Alabama, 1975.

In addition, the Awarded Vendor, if non-resident of the State, and if a corporation, shall show evidence of having qualified with the Secretary of State to do business in the State of Alabama. For more information, or to register, go to the following website for the State of Alabama: <http://sos.alabama.gov/business-entities>.

**CONTRACTOR** must have a current business license or purchase a business license with the City of Fairhope prior to work performed. No **BIDS** shall be withdrawn for the period of thirty (30) days after the opening of proposals without the consent of the City of Fairhope, Baldwin County, Alabama. Once completed, a tabulation of the responsive and responsible Quotes will be available for public viewing.

## SCOPE OF WORK AND SPECIFICATIONS

### BID 030-21 Covered Slip Roof and Framing Repairs at the Docks —FEMA 4563

#### GENERAL SCOPE

1.01 The Awarded Vendor to provide the following equipment per Specifications:

#### REPAIR OF EXISTING ROOF AND WOOD STRUCTURE BID:

The City of Fairhope is requesting responses to repair and replace portions of galvalume roof and wood structure/sheathing on the Covered Slips Pavilion at Fairhope Docks located at 848 Sea Cliff Drive, Fairhope, Alabama. During Hurricane Sally, September 16, 2020, this mono-sloped pile and braced roof system was damaged. Damage includes loss of R-panels, broken/racked bracing and loss of end-wall fascia sheathing. The respondent shall submit a lump sum price to completely repair and replace the roof to current code standards. The lump sum price should include all material, equipment, tools, labor, and incidentals to deliver a complete "turnkey" replaced roof system

#### SCOPE OF WORK:

Work shall include, provide all labor, equipment, materials and incidentals to complete the following work, including but not limited to:

- Replace missing galvalume roofing panels lost to wind impacts from HC Sally - Minimum 425 SQ. FT.
- Refasten and/or replace all roof panel fasteners within the entire field - ± 9,600 SQ. FT.
- Repair and/or replace all damaged top plates, rafters, purlins, bracing and all other wood superstructure.
- Add additional X-Bracing as shown on plan
- Replace all fascia skirting (T1-11 Siding) at upper end of covered slips

#### 1.02.2 **Critical Timelines**

- 15-day Notice to Proceed
- 21 Calendar Days allowed for work (no exceptions for holidays)

#### 1.02.3 General Notes

1. Contractor will be required to be **Licensed, Bonded, and Insured**. Documents will be required at time of bid acceptance and issuance of purchase order.
2. Work must be completed 28 calendar days from the end of "Notice to Proceed" period.
3. Enclosed scope of work, descriptions, quantities, etc. are "good faith" estimates only. Prior to submitting quotations contractor should field measure and verify all quantities.
4. Bids will be treated and considered as "lump sum" bids for all described work.
5. Only one pay request will be accepted and processed upon final acceptance of work.
6. Job Bids are subject to the GENERAL CONDITIONS, SPECIAL PROVISIONS and SUPPLEMENTAL SPECIFICATIONS as attached.
7. Questions, inquiries and requests for clarification should be directed to Richard D. Johnson, PE; Director of Public Works: Phone -(251) 928-8003; or by Email [richard.johnson@fairhopeal.gov](mailto:richard.johnson@fairhopeal.gov)
8. **Sealed Bids must be received by 1:00 PM - Tuesday, August 3, 2021**, at the Purchasing Department; 555 South Section Street; Fairhope, AL 36532

1.02.4 Vendor Compliance

**Items Bid must comply with all specifications listed.**

The Specifications are intended and provided solely as a general and non-exhaustive expression of the intent and purpose of the City of Fairhope regarding this bid; said specifications should be so considered by the bidders. The use of specific names is not intended to restrict the bidder, or any seller, or manufacturer, but is solely for the purpose of indicating the type, size and quality of materials, product services, or equipment best suited for the City of Fairhope. Accordingly, the bidder admits and agrees that said specifications are not complete in every detail and that the work and materials not indicated or expressly mentioned in said specifications, but which are reasonably necessary for the full and faithful performance of the item(s) bid in accordance with the full and faithful intent, will be included in the bid and incorporated in the work by the bidder and at the bidder's sole expense, the same as if indicated and specified.

**WARRANTY**

The awarded vendor expressly warrants that all articles, materials, and work offered shall conform to each and every specification, drawing, sample, or other description which is furnished to or adopted by the City of Fairhope, and that it will be fit and sufficient for the purpose intended, merchantable, of good material and workmanship, and free from defects. The awarded vendor further warrants all items for a period of one year, unless otherwise stated, from the date of acceptance of the items delivered and installed or work completed. All repairs, replacements, or adjustments during the warranty period will be at the awarded vendor's sole expense. Awarded vendor will provide written warranty for all parts and labor for a period of (1) one year commencing from date of written acceptance of delivery by City of Fairhope. Awarded vendor will provide written copies of all other applicable warranties, such as, Manufacturer's warranty. Those warranties, if any, will be in addition to the awarded vendor's warranty, and the terms of which will not be altered by the awarded vendor's warranty.

**Additional Specifications**

1. All work to be done in a neat and professional manner.
2. All applicable licenses, including a City of Fairhope business license, and necessary **permits** to be acquired by **CONTRACTOR**. The **permit fees for this project are waived for the Contractor**.
3. **CONTRACTOR** to provide all necessary services and materials unless stated otherwise above.
4. **CONTRACTOR** to comply with all applicable laws, codes, and regulations, including safety, fire, health, environmental and insurance. **CONTRACTOR** will perform all work in compliance with meeting or exceeding Manufacturer's and industry standards.
5. **CONTRACTOR** to cleanup job site and remove all waste and non-salvageable material in accordance with applicable laws, codes and regulations.
6. The **CONTRACTOR** will be responsible for all minor facilities and equipment damages (e.g., paint, drywall, etc.) caused by the **CONTRACTOR** resulting from negligence during the execution of this contract. This includes but is not limited to damage too small to be covered by the **CONTRACTOR'S** insurance.
7. Written change proposals shall be provided to the project manager by the **CONTRACTOR** for any requested modification to the plans, specifications or other contract requirements. The proposal shall include add-on or deduct costs, if any. The project manager will return an approved change order prior to any change implementation.
8. All salvageable material remains property of the City of Fairhope, and to be delivered by **CONTRACTOR** to the City of Fairhope Warehouse, 555 South Section Street, Fairhope, Al.

**GENERAL NOTES:**

1. All wood shall be Pressure Treated (2.5 CCA), Southern Yellow Pine
2. All through bolts or threaded rod fastening through piles and/or structural elements shall be  $\frac{3}{8}$ "  $\varnothing$  hot dipped galvanized steel with  $2x2x\frac{1}{4}$ " hot dipped galvanized plate washers at each connection point.
3. Roof Panel - 26-gauge, 36" Wide, PBR Roofing Panel, R-Loc or Equivalent, Galvalume Plus (exposed fastener)
4. Galvalume panels shall be attached to wood purlins with 1- $\frac{1}{2}$ " in. #10 Galvalume Metal to Wood Screw.
5. Panel to purlin connections spacing shall be 6" O.C. Spacing at endlaps to be 6" O.C. Spacing for panel to panel connections to be 12" O.C.
6. All work proposed should match dimensions and geometric's of existing structure(s). Any areas of conflict should be addressed with the Director of Public Works prior to work.
7. All new and repair work shall be conducted and completed without damage to the existing covered slip structure.
8. In Situ field conditions may require geometric adjustments of top plates, rafters, purlins and braces - contractor shall be allowed to make adjustments in the field with review and approval of the Director of Public Works.

**1**  
01 TYPICAL "Y" BRACING CROSS SECTION

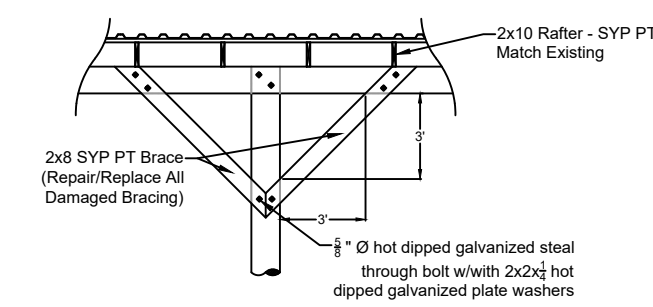

**2**  
01 TYPICAL "X" BRACING CROSS SECTION

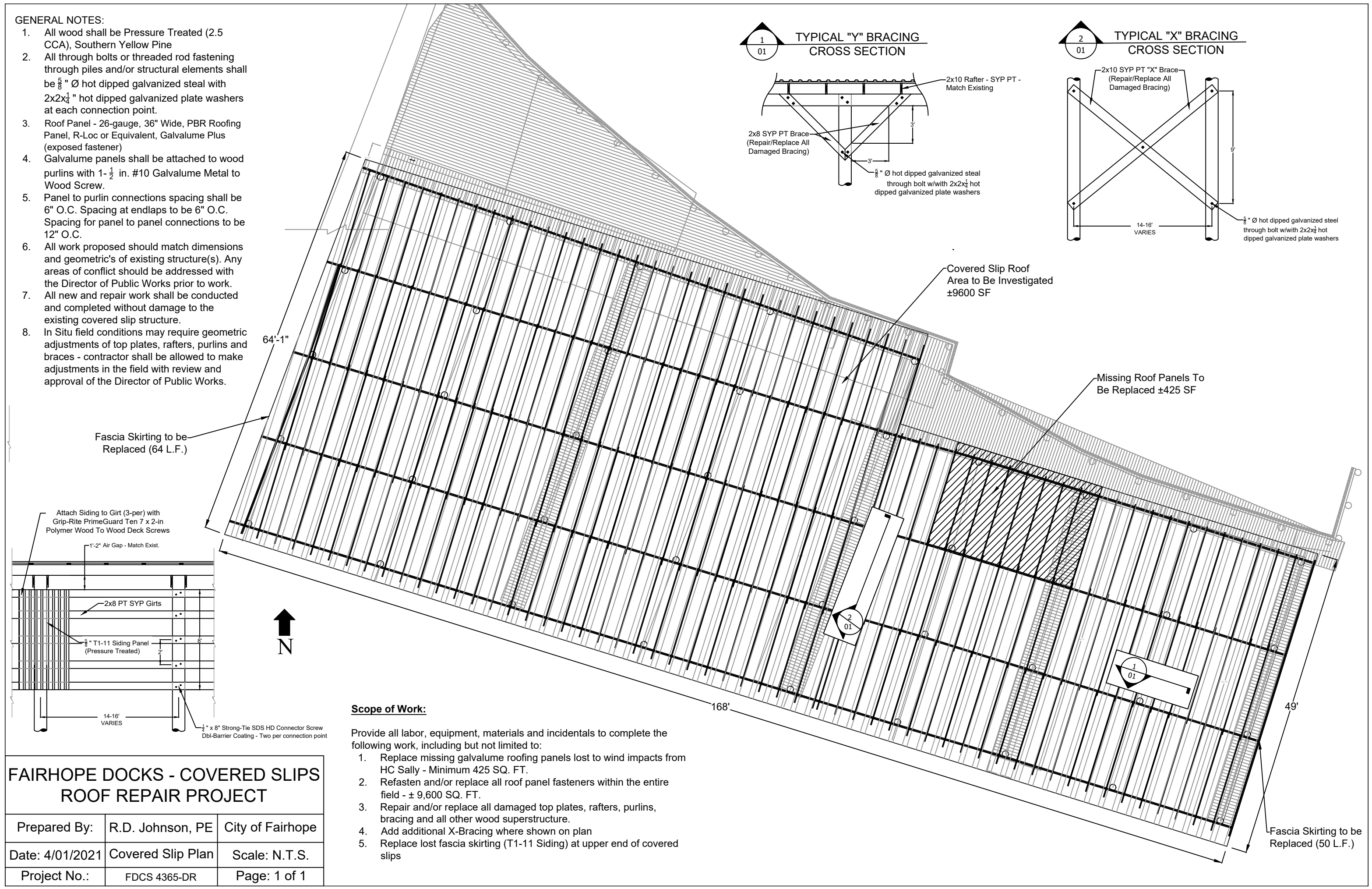
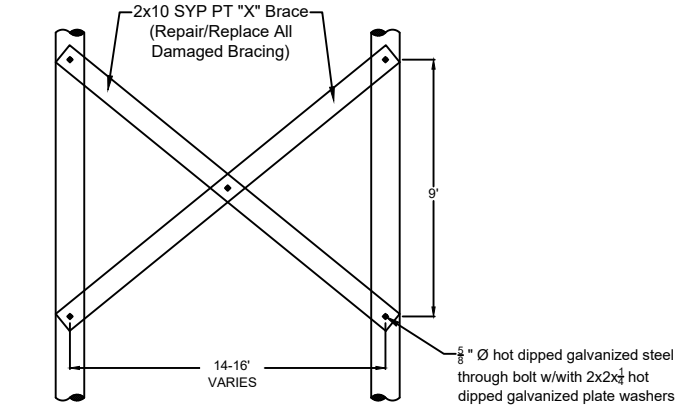

Fascia Skirting to be Replaced (64 L.F.)

Covered Slip Roof Area to Be Investigated ±9600 SF

Missing Roof Panels To Be Replaced ±425 SF

Fascia Skirting to be Replaced (50 L.F.)

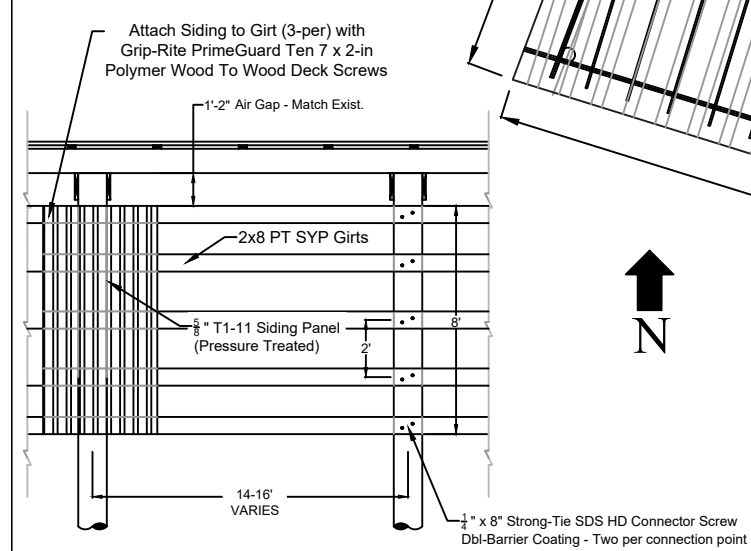

<b>FAIRHOPE DOCKS - COVERED SLIPS ROOF REPAIR PROJECT</b>		
Prepared By:	R.D. Johnson, PE	City of Fairhope
Date:	4/01/2021	Covered Slip Plan
Project No.:	FDCS 4365-DR	Scale: N.T.S.
		Page: 1 of 1

**Scope of Work:**

- Provide all labor, equipment, materials and incidentals to complete the following work, including but not limited to:
1. Replace missing galvalume roofing panels lost to wind impacts from HC Sally - Minimum 425 SQ. FT.
  2. Refasten and/or replace all roof panel fasteners within the entire field - ± 9,600 SQ. FT.
  3. Repair and/or replace all damaged top plates, rafters, purlins, bracing and all other wood superstructure.
  4. Add additional X-Bracing where shown on plan
  5. Replace lost fascia skirting (T1-11 Siding) at upper end of covered slips



**CITY OF FAIRHOPE  
BID RESPONSE FORM**

DATE: \_\_\_\_/\_\_\_\_/\_\_\_\_

**BID 030-21 Covered Slip Roof and Framing Repairs at the Docks —FEMA 4563**

Base bid will include all labor, materials, equipment, shipping, overhead, profit, bonds, insurance and all other costs necessary to provide the complete services outlined within the Contract and Scope of Work.

**CRITICAL TIMELINES:**

- 15-day Notice to Proceed Period**
- 28 Calendar Days allowed for work (no exceptions for holidays)**

We propose to meet or exceed the above specifications at: (see Scope of Work and Specifications):

ITEM	DESCRIPTION	UNIT	UNIT PRICE*	UNIT QTY	TOTAL PRICE
1	New 26-Ga Galvalume Roof Panels	SF		425	
2	Replace Roof Panel Fasteners	SF		9,600	
3	Repair/Replace Damaged Wood Superstructure	LS		1	
4	New X-Bracing	Each		10	
5	Replace Fascia Skirting	SF		904	
<b>TOTAL BID:</b>					

\* **Note: unit price shall include all components of a replacement and/or repair of roof system and wood superstructure described herein, such as mobilization, demo, disposal, hardware, incidentals, etc.**

Addenda No: \_\_\_\_\_

Each bid must give the full business address of the bidder and must be signed by him with his usual signature. Bids by partnerships must furnish the full names of all partners and must be signed with the partnership name by one of the members of the partnership, or by an authorized representative, followed by the signature and designation of the person signing. Bids by corporations must be signed with the legal name of the corporation followed by the name of the State of Incorporation and by the signature and designation of the president, secretary, or other person authorized to bind it in the matter. The name of each person shall also be typed or printed below the signature. A bid by a person who affixes to this signature the word "president," "secretary," "agent," or other designation without disclosing his principal, may be held to be the bid of the individual signing. When requested by the City of Fairhope, Baldwin County, Alabama, satisfactory evidence of the authority of the officer signing in behalf of the corporation shall be furnished.

The undersigned agrees to furnish the goods/services as requested by you for the City of Fairhope, Baldwin County, Alabama in your invitation to bid, and certifies that they will meet or exceed the specifications called for. The undersigned has read all information pertaining to this bid and has resolved all questions. It is also understood and agreed that all prices Bid are F.O.B. described in the bid documents and specifications. The undersigned also affirms he/she has not been in any agreement or collusion among

bidders or prospective bidders in restraint of freedom of competition, by agreement to bid at a fixed price or to refrain from bidding or otherwise.

Witness our hands this \_\_\_\_ day of \_\_\_\_\_, 2021.

**Corporation or LLC**

Company \_\_\_\_\_ State of Incorporation \_\_\_\_\_

Company Representative \_\_\_\_\_  
(Print Name of Representative Authorized to sign Quotations and Contracts for the firm)

Company Representative \_\_\_\_\_  
(Signature of Representative Authorized to sign Quotations and Contracts for the firm)

Address \_\_\_\_\_

\_\_\_\_\_

\_\_\_\_\_

Phone Number \_\_\_\_\_ Fax Number \_\_\_\_\_

Primary e-mail address \_\_\_\_\_

Alabama Contractor's License No. \_\_\_\_\_ Alabama Foreign Corporation \_\_\_\_\_

**NOTARY FOR CORPORATION, PARTNERSHIP OR JOINT VENTURE**

STATE OF \_\_\_\_\_ }

COUNTY OF \_\_\_\_\_ }

I the undersigned authority in and for the said State and County, hereby certify that \_

\_\_\_\_\_ title \_\_\_\_\_

of \_\_\_\_\_

**Print** Company Name

whose name(s) is signed to the foregoing document and who is known to me, acknowledged before me on this day, that, being informed of the contents of the document they executed the same voluntarily on the day the same bears date.

Given under my hand and Notary Seal on this \_\_\_\_ day of \_\_\_\_\_, 2021.

Notary Public \_\_\_\_\_

My Commission Expires \_\_\_\_\_

**END OF Bid RESPONSE FORM**



## INSTRUCTIONS TO BIDDERS

**NOTE: THIS DOCUMENT CONTAINS IMPORTANT BIDDING AND CONTRACTING INFORMATION.  
ALL POTENTIAL BIDDERS SHOULD READ IT THOROUGHLY**

2.00 **BID INVITATION**

Notice is hereby given that the City of Fairhope will receive **sealed bids** on the work described herein. Qualified bidders are invited to submit bids on this work.

2.1 **BID 030-21 Covered Slip Roof and Framing Repairs at the Docks (FEMA 4563)**

2.2 **BID DEADLINE**

SEALED Bids will be received by [DeeDee.Brandt@fairhopeal.gov](mailto:DeeDee.Brandt@fairhopeal.gov) until **1:00 p.m. local time, Tuesday, August 3, 2021** at the City of Fairhope offices located at 555 S. Section Street, Fairhope, Alabama, by the designated time above.

2.3 **AVAILABILITY OF DOCUMENTS**

Prior to opening, Bid packets may be obtained on the City of Fairhope website at or requested by email from Dee Dee Brandt, Purchasing Manager, at [DeeDee.Brandt@fairhopeal.gov](mailto:DeeDee.Brandt@fairhopeal.gov). Specifications are on file and may be seen in the Purchasing Department of the City of Fairhope, Alabama, 555 S. Section Street, between 7:00 A.M. and 4:00 P.M. local time. One set of Bid Documents can be obtained free of charge.

2.4 **INQUIRIES**

Questions or comments pertaining to this Bid must be presented in writing, and sent as e-mail to the attention of the Purchasing Manager, Dee Dee Brandt at [DeeDee.Brandt@fairhopeal.gov](mailto:DeeDee.Brandt@fairhopeal.gov) no less than Seventy-Two (72) hours prior to the Bid opening or will be forever waived.

2.5 **SITE EXAMINATION / CITY PROVISION / NON-RESIDENT STATE RECIPROCITY**

The City of Fairhope will not furnish any labor, material or supplies unless specifically stated in the Contract documents. CONTRACTOR must be properly licensed to perform the work as outlined in the Scope of Work. **Bidder must have a current business license or purchase a business license with the City of Fairhope prior to or (upon) Bid being awarded.** Where required by State law, State of Alabama CONTRACTOR's license is required.

Except for Contracts funded in whole or in part by funds received from a federal agency, preference shall be given to resident CONTRACTORS on the same basis as the non-resident Bidder's state awards contracts to Alabama CONTRACTORS bidding under similar circumstances. Therefore, non-resident bidders shall submit with their Bid a written opinion of an attorney at law licensed to practice law in the non-residents bidder's state of domicile as to preferences granted by the state to entities doing business in that state when letting public contracts.

2.6 **PRE-BID MEETING / SITE EXAMINATION**

A **mandatory** pre-bid meeting to be held at the Fairhope City Council Chambers at 161 N. Section Street, Fairhope, AL, at **10:00 A.M. Tuesday, July 27, 2021.**

Before submitting a bid proposal for the Project, each Bidder shall carefully examine the Contract Documents, including but not limited to plans, drawings, specifications, contract, etc.; visit the site, and satisfy itself as to the nature and location of the Project, and the general and local conditions, including weather, the general character of the site or building, the character and extent of existing work within or adjacent to the site, and any other work being performed or proposed thereon at the time of submission of their bids. It shall obtain full knowledge as to transportation, disposal, handling, and storage of materials, availability of water, electric power, and all other facilities in the area which will

have a bearing on the performance of the Project for which they submit their bids. The submission of a bid shall be prima facie evidence that the Bidder has made such examination and visit and has judged for and satisfied himself as to conditions to be encountered regarding the character, difficulties, quality, and quantities of work to be performed and the material and equipment to be furnished, and as to the contract requirements and contingencies involved. It shall be the Bidder's obligation to verify for himself and to his complete satisfaction, all information concerning site and surface conditions

2.7

**BID SECURITY**

Bids shall be accompanied by a Bid Security equal to 5% (percent) of the bid price, but in no event more than \$10,000.00. Bid Security shall be in the form of a Bid Bond or Cashier's Check payable to the City of Fairhope. No Bid Security is required on bid less than \$10,000.00. Should the successful Bidder or Bidders to whom a Contract is awarded fail to execute a contract(s) and furnish acceptable Contract securities and evidence of insurance, as required, **within fifteen (15)** days after the prescribed forms have been presented to him/her, the CITY may retain from the proposal guaranty, if it is a cashier's check or recovered from the principal or the sureties, if the guaranty is a Bid Bond, the difference between the amount of the Contract as awarded, and the amount of the proposals of the new lowest Bidder. If no other bids are received, the full amount of the proposal guaranty may be so retained and recovered as liquidated damages for such default. Any sum so retained or recovered shall be the property of the awarding authority.

2.8

**PERFORMANCE ASSURANCE AND INSURANCE**

The vendor to whom award is made shall provide a **Performance Bond** equal to 100% of the Contract Amount and a **Labor and Materials Bond** equal to 50% (percent) of the Contract amount. The Awarded Vendor shall also provide insurance as required in section titled ITEM III INSURANCE and shall name the City of Fairhope as additional insured.

2.9

**DURATION OF OFFER**

Bids may be withdrawn by written or telegraphic request received from the Bidder prior to the time fixed for opening. No bid shall be withdrawn for a period of THIRTY (30) days subsequent to the opening of Bid without the consent of the City Council of the City of Fairhope.

2.10

**EQUAL OPPORTUNITY**

The City of Fairhope is an Equal Opportunity Employer and requires that all CONTRACTORS comply with the Equal Employment Opportunity Laws and the provisions of the Contract documents in this regard. The City also encourages and supports the utilization of Minority Business Enterprises on this and all public Quotes.

2.11

**BID SUBMISSION AND PREPARATION**

Submit sealed bids to the City Services Building located at 555 S. Section St., Fairhope, AL, by the date and time listed in the Bid

2.11.1

Forms furnished, or copies thereof, shall be used, and strict compliance with the requirements of the Invitation, these instructions, and the instructions printed on the forms is necessary. Special care should be exercised in the preparation of BIDS. Bidders must make their own estimates of the facilities and difficulties attending the performance of the proposed contract, including local conditions, uncertainty of weather, and all other contingencies. All designations and prices shall be fully and clearly set forth. The proper space in the Bid forms shall be suitable filled in.

2.11.2

Fill in all blanks on the Bid Response Form with non-erasable ink or type. Erasers or other changes must be explained or noted over the signature of the Bidder.

2.11.3

The Bid Response Form may have a Contingency Allowance listed. Add this amount to the Bid Base to derive the Total Bid. The Contingency Allowance covers unforeseen conditions and shall not be used by the CONTRACTOR without the written authorization

of the Owner. At the conclusion of the project, the unused portion of the Contingency Allowance shall revert to the Owner. **Note: Not applicable to this BID**

- 2.11.4 Each BID must give the full business address of the bidder and must be signed by him with his usual signature. Bid by partnerships must furnish the full names of all names of all partners and must be signed with the partnership name by one of the members of the partnership, or by an authorized representative, followed by the signature and designation of the person signing. Bid by corporations must be signed with the partnership name by one of the members of the partnership, or by an authorized representative, followed by the signature and designation of the person signing. Bid by corporations must be signed with the legal name of the corporation followed by the name of the State of Incorporation and by the signature and designation of the president, secretary, or other person authorized to bind it in the matter. The name of each person who affixes to this signature the word "president", "secretary", "agent", or other designation without disclosing his principal, may be held to be the Bid of the individual signing. When requested by the City of Fairhope, satisfactory evidence of the authority of the officer signing in behalf of the corporation shall be furnished.
- 2.11.5 Each project will be Bid separately unless otherwise expressly requested in the contract document. Combination Bid, that is, Bids on separate projects lumped together as a single Bid or on all or none basis, will not be accepted unless the contract document expressly requests or permits same. Alternate Bid will not be considered unless requested. Bidders are to provide with their Bid, a reference list to include name/address/phone number.
- 2.12 **BID INELIGIBILITY**  
Bid that contain irregularities of any kind may be declared unacceptable at the discretion of the Owner. The Owner may waive any minor irregularities and may reject any or all Bid. Bid received after the deadline will be returned to the bidder unopened.
- 2.13 **CONTRACT TIME**  
The CONTRACTOR agrees to perform the work within the time stated in the Bid. The bidder in submitting an offer accepts the conditions of the contract period stated for performing the work
- 2.14 **RESPONSIBLE BIDDERS / RESPONSIVE BIDS**  
The CITY reserves the right to reject any bid that is submitted by a Bidder that is determined by the CITY to not be a responsible Bidder or whose bid is not responsive. In determining whether a Bidder or bid is responsible and/or responsive, the CITY reserves the right to also request and consider the following factors:
- 2.15 **CONSTRUCTION DOCUMENT IDENTIFICATION**  
The Construction documents are the Bid Packet, Drawings, Addenda, and all other related documents bearing the Project Title and Number. Bidders shall use complete sets of Construction Documents in preparing their Bids. The City will not assume responsibility for errors or misinterpretation resulting from the use of incomplete sets of Construction Documents.
- 2.16 **INQUIRIES/ADDENDA**  
Questions or comments pertaining to this Bid must be presented in writing, sent as e-mail to the attention of the Purchasing Manager, Dee Dee Brandt at [DeeDee.Brandt@fairhopeal.gov](mailto:DeeDee.Brandt@fairhopeal.gov), Seventy-Two (72) hours prior to the Bid opening or will be forever waived.
- 2.16.1 All Addenda and attachments are part of the Contract Documents. Include resultant costs in the Bid. Addenda will be issued by posting to the City of Fairhope website, [www.fairhopeal.gov](http://www.fairhopeal.gov) and posted on the City's bulletin board at 555 South Section St., Fairhope, AL. **It is the responsibility of the bidder to obtain any addenda and verify that all addenda have been received.**
- 2.17 **Bid ACCEPTANCE**  
Bid with lowest Total amount from a responsive and responsible bidder may be accepted if within the contract budget. If alternates are listed on the Bid Response Form, the lowest

combination of Total Bid and Alternate Bid accepted by the owner shall be the accepted Bid. Alternates shall be awarded in the order in which they are listed on the Bid Response Form.

2.18

**BIDDERS INTERESTED IN MORE THAN ONE BID**

If more than one Bid is offered by any one party, by or in a name of his clerk, partner, corporation in which he has a substantial interest, or in which he is an officer, or other person, all such may be rejected. A party who has quoted prices on materials to a Bid is not thereby disqualified from quoting prices to other bidders or from submitting a Bid directly for the materials or work. The City reserves the right to determine in its discretion whether the provisions of this clause have been violated by any bidder.

2.19

**ERRORS IN BIDS**

Bidders or their authorized agents are expected to examine the maps, drawings, specifications, and all other instructions pertaining to the work, which will be open to their inspection. Failure to do so will be at the bidder's own risk. In case of error, in the extension of prices the unit price will govern.

2.20

**CONTRACT AND BOND**

The bidder to whom award is made must, when requested, enter into written contract on the standard form as set out herein, with satisfactory security in the amount required, within the period specified, or, if no period be specified, within 15 days after the required forms are presented for signature.

2.21

**COLLUSION**

If there is any reason for believing that collusion exists among the Bidders, any or all Bids may be rejected, and those participating in such collusion may be barred from submitting Bids on the same or other work with the City.

2.22

**SUBLETTING OR ASSIGNING OF CONTRACT**

Limitations: The CONTRACTOR shall not sublet, assign, transfer, convey, sell or otherwise dispose of any portions of the contract, his right, title, or interest therein, or his power to execute such contract, to any person, firm or corporation without written consent of the City, and such written consent shall not be construed to relieve the CONTRACTOR of any responsibility for the fulfillment of the contract. Unless otherwise stipulated in the proposal or special provisions, the CONTRACTOR shall perform with his own organization, and with the assistance of workmen under his immediate superintendence and reported on his payroll, all contract work of a value not less than 50 percent of the total contract amount, except that any items designated in the contract as "Specialty Items" so performed by sub-contract may be deducted from the total contract amount before computing the amount of work required to be performed by the CONTRACTOR with his own organization.

2.22.1

**SUB-CONTRACTOR'S Status:** A SUB-CONTRACTOR shall be recognized only in the capacity of an employee or agent of the CONTRACTOR and the CONTRACTOR will be responsible to the City for all of the Sub-CONTRACTOR'S work, including failures or omissions; and his removal may be required by the Project Manager, as in the case of an employee.

2.23

**PROSECUTION OF WORK**

The CONTRACTOR shall commence work as otherwise directed in writing per specifications.

2.23.1

The CONTRACTOR shall prosecute the work continuously and diligently in the order and manner set out in his schedule as approved by the City. He shall provide sufficient satisfactory materials, labor, and equipment to ensure that the work will be completed in a satisfactory manner within the time specified in the contract.

2.23.2

Should the CONTRACTOR fail to maintain a satisfactory rate of progress, the City may require that additional forces and/or equipment be placed on the work to bring the project up to schedule and maintain it at that level.

- 2.22.3 Should the Contract fail to furnish sufficient satisfactory equipment and/or labor for maintaining the quality and progress of the work at satisfactory level, the City may withhold all estimates that may become due until satisfactory quality and progress are maintained; or the contract may be annulled.
- 2.24 **MATERIALS AND WORK CREW**  
All materials, which the engineering plans specify or are required, will be installed as they are shown on the drawings, plans and/or specs.
- 2.24.1 Brand names, catalog numbers, weights, etc., are used to indicate levels of quality only and are not intended to restrict the bidding. If bidding on an item of another brand or manufacturer than that specified, Bidder's bid should be accompanied by brochures or other pertinent literature giving detailed specifications of the item(s) on which the bid is being made. Bids received without sufficient literature to determine equal quality may not be considered. Final determination as to equal quality will be made by the CITY.
- 2.24.2 Quantities: The quantities shown in the bid packet shall be considered by the contractor as the quantities required to complete the work for the purpose of bidding. During the course of work, the prices bid for adjustment items may be used by the CITY to increase or decrease the total cost for the work if the quantity of work exceeds or is less than the amount shown on plans.
- 2.24.3 Construction Crews: The Contractor will be required to furnish at least one separate construction crew during the work as set forth in the contract. Unless waived by the CITY, the Contractor shall perform on the sites and with his own organization and equipment, at least fifty percent of the total amount of the work to be performed under this Contract. The Contractor may only subcontract a maximum of fifty (50%) percent of the work without CITY consent. If, during the progress of the work hereunder, the Contractor requests a reduction of such percentage, and the CITY representative determines that it would be to the CITY's advantage, the percentage of the labor required to be performed by the Contractor's own organization may be reduced; PROVIDED prior written approval of such reduction is obtained by the Contractor from the CITY.
- 2.25 **GENERAL CONTRACTOR'S LICENSE**  
The attention of all Bidders is called to the provisions of the State law governing General Contractors as set forth in Ala. Code §34-8-1 et seq. (1975), particularly in regard to the need for and evidence of a State General Contractor's license. The provisions of said statute are adopted herein by reference and form a part of the Contract with the selected Bidder should this Project be awarded. **Bidder MUST include with his bid a State of Alabama Contractor's current license number and a copy of the license. State law, Ala. Code §34-8-8(b) (1975) requires all bids to be rejected which do not contain General Contractor's license number on the outside of the bid response sealed envelope.**
- 2.25.1 Bidders are reminded that they will be governed by said statutes insofar as they are applicable. To summarize the above quoted statutes, Ala. Code §34-8-1, et seq. (1975) provides that no one is entitled to bid, and no contract may be awarded to anyone who does not possess a valid general contractor's permit or license, including specialty classifications for the work, as provided by the foregoing sections of the State Code, and rules and regulations promulgated pursuant thereto and that said bid may not be considered without evidence being produced that he is so qualified. Trade Contractors must be duly licensed in accordance with applicable law.
- 2.25.2 CONTRACTOR must be properly licensed to obtain City of Fairhope permits and perform the work as outlined in the Scope of Work. Bidder must have a current business license or purchase a business license with the City of Fairhope prior to or (upon) bid being awarded. Sub-contractors must also comply with this provision.
- 2.26 **U. S. PRODUCTS PREFERENCE**  
The successful Bidder (Contractor) shall comply with Ala. Code §39-3-1 (1975), shall agree to utilize in the execution of the Project, materials, supplies and products



manufactured, mined, processed or otherwise produced in the United States or its territories, if the same are available at reasonable and competitive prices and not contrary to any sole source specifications. It is further stipulated that a breach of the foregoing provision of this agreement by the contractor in failing to utilize domestic products shall result in a downward adjustment in the Contract price equal to any realized savings or benefit to the Contractor.

2.27

**USE OF DOMESTIC STEEL**

The attention of all Bidders and that of the successful Bidder (CONTRACTOR) is drawn to Ala. Code §39-3-4 (1975), requiring the use of steel produced within the United States for municipal construction projects when specifications in the Construction Contract require the use of steel and do not limit its supply to a sole source. This provision is subject to waiver if the procurement of domestic steel products becomes impractical as a result of national emergency, national strike or other causes. Violations of the use of domestic steel requirements shall result in a downward adjustment in the Contract price to equal any savings or benefit to the CONTRACTOR.

2.28

**IN STATE BIDDER PREFERENCE**

Pursuant to Ala. Code §39-3-5 (1975), in the letting of public Contracts in which municipal funds are utilized, except those Contracts funded in whole or in part with funds received from a federal agency, preference shall be given to resident contractors, and a non-resident Bidder domiciled in a state having laws granting preference to local contractors shall be awarded Alabama public Contracts only on the same basis as the nonresident Bidders' state awards contracts to Alabama contractors bidding under similar circumstances; and resident contractors in Alabama, as defined in Ala. Code §39-2-12 (1975), be they corporate, individuals or partnerships, are to be granted preference over non-residents in awarding of contracts in the same manner and to the same extent as provided by the laws of the state of the domicile of the nonresident. **The CITY may not enter into a Contract with a nonresident corporation that is not qualified under the State law to do business in Alabama.** Except for contracts funded in whole or in part by funds received from a federal agency, preference shall be given to resident contractors on the same basis as the non-resident Bidder's state awards contracts to Alabama contractors bidding under similar circumstances.

2.29

**APPLICABLE LAWS**

Each Bidder shall inform himself of, and the Bidder awarded a contract shall comply with federal, state, and local laws, statutes, and ordinances relative to the execution of the work. This requirement includes, but is not limited to, applicable regulations concerning minimum wage rates, the use of domestic products, U.S. steel and resident labor, non-discrimination in the employment of labor, protection of public and employee safety and health, environmental protection, the protection of natural resources, fire protection, burning and non-burning requirements, permits, fees and similar subjects. The attention of all Bidders is called to the fact that the work will be subject to compliance with all applicable CITY building and technical codes, including environmental ordinances. Project will be subject, in addition to all other inspections, to inspection by a representative of the City of Fairhope Building Inspections Department.

2.30

**COMPLIANCE WITH IMMIGRATION LAW**

By signing this Contract, the contracting parties affirm, for the duration of the agreement, that they will not violate federal immigration law or knowingly employ, hire for employment or continue to employ an unauthorized alien within the State of Alabama. Furthermore, a Contracting party found to be in violation of this provision shall be deemed in breach of the agreement and shall be responsible for all damages resulting therefrom, to the extent allowed by Federal law (SEE ITEM XI, ALABAMA IMMIGRATION ACT CONTRACT REQUIREMENTS).

**WARRANTY**

The awarded vendor expressly warrants that all articles, materials, and work offered shall conform to each and every specification, drawing, sample, or other description which is furnished to or adopted by the City of Fairhope, and that it will be fit and sufficient for the purpose intended, merchantable, of good material and workmanship, and free from defects. The awarded vendor further warrants all items for a period of one year, unless otherwise stated, from the date of acceptance of the items delivered and installed or work completed.

All repairs, replacements, or adjustments during the warranty period will be at the awarded vendor's sole expense. Awarded vendor will provide written warranty for all parts and labor for a period of (1) one year commencing from date of written acceptance of delivery by City of Fairhope. Awarded vendor will provide written copies of all other applicable warranties, such as, Manufacturer's warranty. Those warranties, if any, will be in addition to the awarded vendor's warranty, and the terms of which will not be altered by the awarded vendor's warranty.

### **EXCEPTIONS / CHANGES**

1. Compliance with or variations from the specifications must be noted as to each item on the Specification Sheet. This requirement must be met even though the Purchasing Manager may alter the specifications in the form of an addendum to accommodate variances. A request for a change in the specifications to accommodate a variation must be called to the attention of the Purchasing department at least 72 hours before the Bid opening date. All requests for such changes will be considered and the merits weighed. Only those changes in specifications deemed to be in the best interest of the City will be made. In the event of a change in specifications, an addendum will be supplied to bidders. Exceptions may be accepted if they are minor, equal, or superior to that which is specified, and provided that they are listed and fully explained on a separate page entitled, "Exceptions to Specifications". The exceptions shall refer to the specification page and paragraph number. The City shall determine which (if any) exceptions are acceptable and this determination shall be final.



**BID BOND**

The PRINCIPAL (Bidder's name and address)

The OWNER

City of Fairhope  
P.O. Drawer 429  
Fairhope, Al 36533

The PROJECT for which the Principal's Bid is submitted:

**Project No. PW012-21**  
**Project Name: Covered Slips Roof Repairs**

KNOW ALL MEN BY THESE PRESENTS, that we, the undersigned Principal and Surety, jointly and severally, hereby bind ourselves, our heirs, executors, administrators, successors, and assigns to the OWNER in the PENAL SUM of five percent (5%) of the amount of the Principal's bid, but in no event more than Ten Thousand dollars(\$10,000).

THE CONDITION OF THIS OBLIGATION is that the Principal has submitted to the Owner the attached bid, which is incorporated herein by reference, for the Project identified above.

NOW, THEREFORE, if, within the terms of the Bid Document, the OWNER accepts the Principals bid and the Principal thereafter either:

- (a) executes and delivers a Construction Contract with the required Performance and Payment Bonds (each form contained in the Bid Documents and properly completed in accordance with the bid) and delivers evidence of insurance as prescribed in the Bid Documents, or
- (b) fails to execute and deliver such Construction Contract with such Bonds and evidence of insurance, but pays the OWNER the difference, not to exceed the Penal Sum of this Bond, between the amount of the Principal's Bid and the larger amount for which the OWNER may award a Construction Contract for the same work to another Bidder, then this obligation shall be null and void, otherwise it shall remain in full force and effect.

The Surety, for value received, hereby stipulates and agrees that the obligation of the Surety under this Bond shall not in any manner be impaired or affected by any extension of the time within which the OWNER may accept the Principal's bid, and the Surety does hereby waive notice of any such extension.

SIGNED AND SEALED this \_\_\_\_\_ day of \_\_\_\_\_, 2021

ATTEST:

\_\_\_\_\_

\_\_\_\_\_  
Principal (Company)

By \_\_\_\_\_

\_\_\_\_\_  
Print name and title

SURETY ATTEST

\_\_\_\_\_

\_\_\_\_\_  
SURETY COMPANY

By \_\_\_\_\_

\_\_\_\_\_  
Print name and title

**PERFORMANCE BOND**

KNOW ALL MEN: That \_\_\_\_\_ as Principal,  
(name & address of legal title of contractor)  
and \_\_\_\_\_ and  
(name & address of legal title of one or more sureties)  
\_\_\_\_\_  
(name & address of legal title of one or more sureties)

Hereinafter called the Surety or Sureties, are held and firmly bound unto the CITY OF FAIRHOPE, ALABAMA, hereinafter called the OWNER in the sum of \_\_\_\_\_ Dollars ( \$XXX), for the payment whereof the Principal and the Surety or Sureties bind themselves, their heirs, executors, administrators, successors, and assigns, jointly and severally, firmly by these presents.

WHEREAS, The Principal has, by means of a written agreement, dated \_\_\_/\_\_\_/\_\_\_, entered into a contract with the OWNER for **BID 030-21 Covered Slip Roof and Framing Repairs at the Docks —FEMA 4563**, which agreement is by reference made a part hereof.

NOW THEREFORE, the conditions of this obligation is such that if the Principal shall faithfully perform the contract on his part, and satisfy all claims and demands, incurred for the same, and shall fully indemnify and save harmless the OWNER from all cost and damage which he may suffer by reason of failure to do so, and shall reimburse and repay OWNER all outlay and expense which the OWNER may incur in making good for any such default thence this obligation shall be null and void: otherwise, it shall remain in full force and effect.

PROVIDED, HOWEVER, that no suit, action or proceedings, by reason of any default whatever be brought on his Bond after twelve months from the day on which the final payment under the Contract falls due.

PROVIDED, further, that the said surety or sureties, for value received hereby stipulate and agree that no change, extension of time, or addition to the terms of the Contract or to the work to be performed thereunder of the specifications thereof shall in any way effect their obligations on this bond, and they do hereby waive notice of any such change, extension of time, alteration or addition to the terms of the contract, or to the work, or to the Specifications.

WITNESS our hands this \_\_\_\_\_ day of \_\_\_\_\_, 2021.

**IF INDIVIDUAL**

\_\_\_\_\_, Doing Business As, \_\_\_\_\_  
(SIGNATURE of Individual Bidder) (Business Name)

Business Mailing Address \_\_\_\_\_

**IF CORPORATION**

\_\_\_\_\_  
(Name of Corporation, Partnership , or Joint Venture)

Business Mailing Address \_\_\_\_\_

By: \_\_\_\_\_  
(SIGNATURE of officer authorized to sign Bids and Contracts for the company) (Position or Title)

ATTEST:

\_\_\_\_\_  
(Secretary) (Name of State of incorporation)

\_\_\_\_\_  
(Name of Surety) By: \_\_\_\_\_  
(Attorney in Fact)

**LABOR AND MATERIALS BOND**

KNOW ALL MEN BY THESE PRESENTS, that we \_\_\_\_\_ as

Principal, and \_\_\_\_\_ as Surety, are held and firmly bound unto said **City of Fairhope** hereinafter call the OBLIGEE, in the penal sum of \_\_\_\_\_

\_\_\_\_\_ Dollars ( \$ \_\_\_\_\_ ) lawful money of the United States, for the payment of which sum and truly to be made, we bind ourselves, our heirs, personal representative, successors and assigns, jointly and severally, firmly by these presents.

WHEREAS, said principal has entered into a certain Contract with said OBLIGEE, dated \_\_\_\_/\_\_\_\_/\_\_\_\_. (Hereinafter called the Contract) **BID 030-21 Covered Slip Roof and Framing Repairs at the Docks —FEMA 4563**, which Contract and the Specifications for said work shall be deemed a part hereof as fully as if set out herein.

NOW, THEREFORE, THE CONDITION OF THIS OBLIGATION IS SUCH THAT if the said Principal and all sub-contractors to whom any portion of the work in said contract is sublet and all assignees of said Principal and of such sub-contractors shall promptly make payments to all persons supplying him or them with labor, materials, or supplies for or in the prosecution of the work provided for in such Contract, or any amendment or extension of or addition to said Contract, and for the Payment of reasonable attorney’s fees incurred by the successful claimant or plaintiffs in suits or claims against the Contractor arising out of or in connection with the said Contract, then the above obligation shall be void: otherwise to remain in full force and effect.

PROVIDED, HOWEVER, that this bond is subject to the following conditions and limitations.

(a) Any person, firm or corporation that has furnished labor, materials, or supplies for or in the prosecution of the work provided for in said Contract shall have a direct right to action against the Principal and Surety on this bond, which right of action shall be asserted in a proceeding, instituted in the County in which the work provided for in said Contract is to be performed or in any County in which Principal or Surety does business. Such right of action shall be asserted in a proceeding instituted in the name of the claimant or claimants for his or their use and benefit against the Principal and Surety or either of them (but not later than one year after the final settlement of said Contract falls due) in which actin such claim or claims shall be adjusted and judgment rendered thereon.

(b)The Principal and Surety hereby designate and appoint the Mayor of the City of Fairhope or his successor or representative, as the agent of each of them, to receive and accept services of process or other pleading issued, or filed in any proceeding instituted on this bond and hereby consent that such service shall be the same as personal services on the Principal and/or Surety.

(c) The Surety shall not be liable hereunder for any damages or compensation recoverable under Workmen’s Compensation or Employer’s Liability Statute.

(d) In no event shall the Surety be liable for a greater sum than the penalty of this bond, or subject to any suit, action or proceeding thereon that is instituted later that one year after the final settlement of said contract.

€ This Bond is given pursuant to the terms of an Act of Legislature of the State of Alabama approved February 8, 1935, entitled: “An Act to further provide for Bonds and Contractors on State and other public works and suits thereon”.

Witness our hands this \_\_\_\_ day of \_\_\_\_\_ 2021.

**IF INDIVIDUAL**

\_\_\_\_\_, Doing Business As, \_\_\_\_\_  
(SIGNATURE of Individual Bidder) (Company Name)

Business Mailing Address \_\_\_\_\_  
\_\_\_\_\_

**IF CORPORATION**

\_\_\_\_\_  
(Name of Corporation, Partnership, or Joint Venture)

By: \_\_\_\_\_  
(SIGNATURE of Officer authorized to sign Bid and Contracts for the company) (Position or Title)

\_\_\_\_\_  
(Alabama General Contractor's License Number) Foreign Corp. Entity ID (required of out-of-state Vendors)

**ATTEST:**

\_\_\_\_\_  
( Secretary) (Name of State of Incorporation)

\_\_\_\_\_  
(Name of Surety) (Attorney in Fact)

## ITEM III INSURANCE REQUIREMENTS

### **3.0 INSURANCE REQUIREMENTS**

Awarded Contractor, at its sole expense, shall obtain and maintain in full force the following insurance to protect the Contractor and the City of Fairhope at limits and coverages specified herein. The City of Fairhope will be listed as an additional insured under the Contractor's General Liability insurance and automobile liability insurance policies, and all other applicable policies and certificates of insurance. These limits and coverages specified are the minimum to be maintained and are not intended to represent the correct insurance needed to fully and adequately protect the awarded Bidder.

**3.01** All insurance will be provided by insurers by admitted carriers in the State of Alabama, shall have a minimum A.M. Best rating of A-VII and must be acceptable to the CITY. Self-insured plans and/or group funds not having an A.M. Best rating must be submitted to the CITY for prior approval.

**3.02 NO WORK IS TO BE PERFORMED UNTIL PROOF OF COMPLIANCE WITH THE INSURANCE REQUIREMENTS HAS BEEN RECEIVED BY THE CITY.**

**3.03 Worker's Compensation and Employer's Liability**

Part One: Statutory Benefits as required by the State of Alabama		
Part Two: Employer's Liability	\$1,000,000	each accident
	\$1,000,000	each employee
	\$1,000,000	Policy Limit

**3.04 U.S. Longshoreman & Harbor Workers Act (USL&H)**

Required if contract involves work near a navigable waterway that may be subject to the USL&H law.

**34.05 Maritime Endorsement (Jones Act)**

Endorsement required if contract involves the use of a Vessel. Or include coverage for "Master or Member or Crew" under "Protection and Indemnity" coverage (P&I) unless crew is covered under Workers Compensation.

Bodily injury by accident	\$1,000,000	each accident
Bodily injury by disease	\$1,000,000	aggregate

**3.06 Commercial General Liability**

Coverage on an Occurrence from with a combined single limit of (Bodily Injury and Property Damage combined as follows:

Each occurrence	\$1,000,000
Personal and Advertising Injury	\$1,000,000
Products/Completed Operation Aggregate	\$2,000,000
General Aggregate	\$2,000,000

Coverage to include:

- Premises and operations
- Personal injury and Advertising Injury
- Products/completed operations
- Independent Contractors
- Blanket Contractual Liability
- Explosion, Collapse and Underground hazards
- Broad Form Property Damage
- Railroad Protective Liability Insurance if work involves construction, demolition, or maintenance operations on or within 50 feet of a railroad.

**3.07 Automobile Liability**

Covering all owned, non-owned and hired vehicles with a limit of no less than \$1,000,000 combined single limit of Bodily injury and property damage per occurrence.

**3.08 Certificates of Insurance**

A Certificate of Insurance evidencing the above minimum requirements must be provided to and accepted 19

by the CITY PRIOR to commencement of any work on the contract. Each policy shall be endorsed to provide ten (10) days written notice of cancellation to the CITY.

**3.08.1** The Contractor shall require certificates of insurance from sub-Contractors. Sub-Contractors will carry limits of insurance equal to or greater than those carried by the Contractor. These certificates shall evidence waivers of subrogation in favor of the Contractor and the CITY, and shall be made available to the CITY upon request.

**CONTRACTOR INFORMATION**

This Section must be printed, completed, and turned in with your bid response

**BID 030-21 Covered Slip Roof and Framing Repairs at the Docks —FEMA 4563**

**Business Organization**

Name of Bidder (exactly as it appears on W-9):

Doing-Business-As Name of Quoter

Principal Office Address:

Telephone Number: \_\_\_\_\_ Fax

Number: \_\_\_\_\_

Email address: \_\_\_\_\_

Website: \_\_\_\_\_

**Form of Business Entity [check one ("X")]**

Corporation \_\_\_\_\_

Partnership \_\_\_\_\_

Individual Joint \_\_\_\_\_

Venture \_\_\_\_\_

Other (describe): \_\_\_\_\_

**Corporation Statement**

If a corporation, answer the following:

Date of incorporation: \_\_\_\_\_

Location of incorporation: \_\_\_\_\_ The

corporation is held: Publicly \_\_\_  
Privately \_\_\_

**Partnership Statement**

If a partnership, answer the following:

Date of organization: \_\_\_\_\_

Location of organization: \_\_\_\_\_ The

partnership is: General \_\_\_  
Limited \_\_\_

**Joint Venture Statement**

If a Joint Venture, answer the following:

Date of organization: \_\_\_\_\_

Location of organization: \_\_\_\_\_ JV

Agreement recorded? Yes \_\_\_  
No \_\_\_

Contact \_\_\_\_\_ Email \_\_\_\_\_

Mailing address \_\_\_\_\_

Phone \_\_\_\_\_

**END OF CONTRACTOR INFORMATION SECTION**



# CITY OF FAIRHOPE, ALABAMA STANDARD TERMS AND CONDITIONS

## 1. ACCEPTANCE OF AGREEMENT

This Agreement contains all terms and conditions agreed upon by the OWNER and Winning bidder. No other agreement, oral or otherwise, regarding the subject matter of this Agreement shall be deemed to exist or to bind either party hereto. The Winning Bidder shall not employ Subcontractors without the express written permission of the OWNER. No waiver, alteration, consent or modification of any of the provisions of the Agreement shall be binding unless in writing and signed by the OWNER and CONTRACTOR. This Agreement shall not be construed against the party or parties preparing it. It shall be construed as if all the parties and each of them jointly prepared this Agreement, and any uncertainty or ambiguity shall not be interpreted against one or more parties.

## 2. ACCEPTANCE OF WORK

The City of Fairhope will be deemed to have accepted the Work after the City of Fairhope agrees the Work is completed by signature on delivery or service tickets. In the event Work furnished under the Contract / Agreement / Purchase Order is found to be defective or does not conform to the intent of the Contract / Agreement / Purchase Order, the awarded vendor shall, after receipt of notice from the City of Fairhope, correct the deficiencies. Failure on the part of the awarded vendor to properly correct the deficiencies within the time period allowed will constitute the City of Fairhope's right to cancel the Contract / Agreement / Purchase Order immediately, upon written notice to the awarded vendor.

## 3. ADDENDA

All Addenda are part of the Contract Documents. Include resultant costs in the Bid. Addenda will be issued by email to all Bidders on record, and posted to the City of Fairhope website [www.fairhopeal.gov](http://www.fairhopeal.gov). It is the responsibility of the bidder to verify that all addenda have been received, and to include all signed addenda in the bid submission

## 4. ADDITIONAL ORDERS

Unless it is specifically stated to the contrary in the bid response, the City of Fairhope reserves the option to place additional orders against a contract awarded as a result of this solicitation at the same terms and conditions; to extend the renewal date until a new bid is in place, if it is mutually agreeable.

## 5. APPLICABLE LAW

This Agreement is deemed to be under and shall be governed by and construed according to the laws of the State of Alabama. Any litigation arising out of the Agreement shall be heard in the Courts of Baldwin County, Alabama.

## 6. ASSIGNMENT

The awarded vendor shall not assign the Contract/Agreement/ Purchase Order or sublet it as a whole without the express written permission of the City of Fairhope. The awarded vendor shall not assign any payment due them hereunder, without the express written permission of City of Fairhope. The City of

Fairhope may assign the Contract / Agreement / Purchase Order, or sublet it as a whole, without the consent of the awarded vendor.

**7. ASSURANCE OF NON-CONVICTION OF BRIBERY** The bidder hereby declares and affirms that, to its best knowledge, none of its officers, directors, or partners and none of its employees directly involved in obtaining contracts has been convicted of bribery, attempted bribery or conspiracy to bribe under the laws of any state or Federal government.

## 8. AWARD CONSIDERATION

The following factors will be considered in determining the lowest **responsible** bidder: Overall quality, Conformity with specifications both general and specific, Purposes for which materials or services are required, Delivery dates and time required for delivery, Unit acquisition cost, financial ability to meet the contract, previous performance, facilities and equipment, availability of repair parts, experience, delivery promise, terms of payments, compatibility as required, other costs, and other objective and accountable factors which are reasonable.

## 9. AWARD OR REJECTION OF BIDS

The Bid will be awarded to the lowest responsible bidder complying with conditions of the invitation for bids, provided his bid is reasonable and it is in the interest of the City of Fairhope to accept it. The bidder to whom the award is made will be notified at the earliest possible date. The City of Fairhope, however, reserves the right to reject any and all bids and to waive any informality in bids received whenever such rejection or waiver is in the interest to the City of Fairhope.

## 10. BACK ORDERS

If it is necessary to back order any items, the vendor must notify the Purchasing Department and advise as to the expected shipping or delivery date. If this date is not acceptable, the City of Fairhope may seek remedies for default.

## 11. BID AND PERFORMANCE SECURITY

If bid security is required, a bid bond or cashier's check in the amount indicated on the bid cover must accompany the bid and be made payable to The City of Fairhope of Baldwin County, Al. Corporate or certified checks are not acceptable. Bonds must be in a form satisfactory to the City and underwritten by a company licensed to issue bonds in the State of Alabama. If bid security fails to accompany the bid, it shall be deemed unresponsive, unless the Purchasing Manager deems the failure to be non-substantial. All checks will be returned to the bidders after the contract has been approved. If a performance bond is required, the successful bidder will be notified after the awarding of the contract.

## 12. BRAND NAMES

Reference to brand names and numbers is descriptive, but not restrictive, unless otherwise specified. Bids on equivalent items meeting the standards of quality thereby indicated will be

considered, providing the bid clearly describes the article offered and indicates how it differs from the referenced brands. Descriptive literature or manufacturers specifications plus any supplemental information necessary for comparison purposes should be submitted with the bid or the bid on that item may be rejected. Reference to literature submitted with a previous bid or on file with the Division of Purchasing will not satisfy this requirement. The burden is on the bidder to demonstrate that the item bid is equivalent to the item specified in the ITB. Bids without sufficient documentation to fully support equality, may be considered non-responsive. Reference by the City of Fairhope in the ITB to available existing specifications shall be sufficient to make the terms of such specifications binding on the bidder. Unless the bidder specifies otherwise in its bid, it is understood the bidder is offering a referenced brand item as specified in the ITB or is bidding as specified when no brand is referenced. Failure to examine drawings, specifications and instructions will be at the bidder's risk.

### **13. BUSINESS LICENSE**

The vendor selected to enter into a Contract / Agreement with the City of Fairhope must be licensed to do business in the City of Fairhope prior to commencement of any work under the contract. Delivery of goods or services to the City of Fairhope by Purchase Order have detailed and varied Business License requirements. In all instances that require a business license. Awarded vendor will provide proof of possessing a current City of Fairhope Business License. Prospective bidders will not be required to possess a City of Fairhope Business License prior to award.

### **14. CANCELLATION OF / CONTRACT / AGREEMENT / PURCHASE ORDER / LEASE**

A purchase order can be canceled in whole or in part when awarded vendor fails to deliver or perform as specified. Cancellation of a purchase order can only be made by a written purchase order change (POC) from the City of Fairhope. A term contract, lease or agreement can be canceled by the City of Fairhope, for justifiable cause, or convenience, by written notice.

### **15. CERTIFICATION PURSUANT TO ACT NO. 2006-557**

Alabama law (section 41-4-116, code of Alabama 1975) provides that every bid submitted and contract executed shall contain a certification that the vendor, CONTRACTOR, and all of its affiliates that make sales for delivery into Alabama or leases for use in Alabama are registered, collecting, and remitting Alabama state and local sales, use, and/or lease tax on all taxable sales and leases into Alabama. By submitting this bid, the bidder is hereby certifying that they are in full compliance with act no. 2006-557, they are not barred from bidding or entering into a contract pursuant to 41-4-116, and acknowledges that the awarding authority may declare the contract void if the certification is false. All corporations must register to do business in Alabama with the Office of the Secretary of State. Their address is:

**Office of the Secretary of State**  
P.O. Box 5616  
Montgomery, AL  
36103 (334) 242-5324

Fax: (334) 240-3138

<http://www.sos.state.al.us/index.aspx>

The Foreign Corporation form is online at

<http://sos.alabama.gov/business-entities>.

### **16. COST OF REMEDYING DEFECTS**

All defects, indirect and consequential costs of correcting, removing or replacing any or all of the defective materials or equipment will be charged against the awarded vendor.

### **17. DELIVERY OF BID**

Bids must be received in the Purchasing Office by the date and time specified on the bid cover. All bids will be accepted until the time and date stated on the bid cover. No bids will be accepted that extend past the time and date on the bid cover. The time of receipt shall be determined by the time clock stamp in the Purchasing Department. Bids submitted by U.S. Mail must be received by the City of Fairhope of Baldwin County, Alabama, in the City of Fairhope offices, 555 South Section St., Fairhope, AL, unless otherwise specified.

### **18. DELIVERY**

The number of calendar days required for delivery after receipt of a purchase order shall be stated in the RFQ / ITB / RFP and /or Purchase Orders. When no time is stated in the document, the time shall be fourteen (14) calendar days after receipt of order. If a shipment is not made within the time period specified, the Purchase Order may be canceled.

### **19. ENVIRONMENTAL REQUIREMENTS**

All products will be clearly labeled for their intended use. Each delivery of product or materials will include a Material Safety Data Sheet (MSDS) for all materials that require an MSDS. All manufacturers/distributors of hazardous substances, including any of the items listed on this bid/quote/ contract and subsequent award must include completed material safety data sheet (MSDS) for each hazardous material. Additionally, each container of hazardous materials must be appropriately labeled with:  
a) The identity of the hazardous material,  
b) Appropriate hazard warnings, and manufacturer, importer, or other responsible party.

### **20. EQUIPMENT DEMONSTRATION**

The City of Fairhope may require equipment/ product materials or service techniques to be demonstrated at a time, date and location to be specified by the City of Fairhope.

### **21. EQUIPMENT ELECTRICAL CERTIFICATION**

All electrical equipment purchased shall conform to, and be identified in, the applicable standard(s), or otherwise be certified as applicable, as of the bid opening date and time, by Underwriters Laboratories, Inc. or other recognized laboratory facility. Bidder must provide satisfactory documentation with returned bid that all such equipment meets the applicable product standard or has otherwise been certified as outlined above. Unless indicated in the bid document, the above certification shall apply to the equipment itself, not the individual components of that equipment.

### **22. ERRORS IN BID**

Bidders are assumed to be informed regarding conditions, requirements and specifications prior to submitting bids.

Failure to do so will be at the bidder's risk. Bids already submitted may be withdrawn without penalty prior to bid opening. Errors discovered after the bid opening may not be corrected.

### **23. FORCE MAJEURE**

Neither the City nor the awarded vendor shall be deemed in breach of any contract / Purchase Order or Agreement which may result from this proposal submission if it is prevented from performing any of the obligations hereunder by reason of Acts of God, acts of the public enemy, acts of superior governmental authority, strikes or labor disputes, floods, riots, rebellion, sabotage, or any similar other unforeseeable causes beyond its control and not due to its fault or negligence. Each party shall notify the other immediately in writing of the cause of such after the beginning period thereof. The awarded vendor may request cancellation and the City of Fairhope may grant the request if performance is prevented by any of the above referenced causes, or other unavoidable circumstances not attributable to the fault or negligence of the vendor. The burden of proof for such relief rests with the vendor. All correspondence pertaining to cancellation of a purchase order or term contract must be addressed to the City of Fairhope Purchasing Manager.

### **24. HAZARDOUS AND TOXIC SUBSTANCES**

Bidder must comply with all applicable Federal, State, County and City laws, ordinances and regulations relating to hazardous and toxic substances, including such laws, ordinances and regulations pertaining to information hazardous and toxic substances, and as amended from time to time. Bidder shall provide the City of Fairhope with a "Material Safety Data Sheet" for all goods that carry one.

### **25. INDEMNITY**

Indemnity: The awarded vendor hereby agrees to indemnify and save harmless the City of Fairhope, its officers, agent, and employees, from and against any and all liabilities, claims, demands, damages, fines, fees, expenses, penalties, suits, proceedings, actions and cost of actions, including reasonable attorneys fees for trial and on appeal, of any kind and nature, arising or growing out of, or in any way connected with the performance of this Contract / Agreement / Purchase Order, to the extent caused by a negligent act or omission of the awarded vendor, their agents, servants, employees, Sub-contractors, or others associated with the awarded vendor. The awarded vendor shall be responsible for damage to any equipment excluded from this agreement, or damage or injury caused by any equipment excluded from this agreement, only to the extent that the damage or injury is caused by a negligent act or omission of the awarded vendor, or caused by failure of the awarded vendor's supplied product to perform as specified.

### **26. INSPECTION**

All materials, workmanship, equipment, and supplies are subject to inspection and test at any source or time. Final inspection, acceptance or rejection will be made at delivery destination. Goods that do not meet specifications will be rejected unless substitutions have been approved by the City of Fairhope. Failure to inspect or to reject upon receipt, however, does not relieve the awarded vendor of liability. When subsequent tests, after receipt, are conducted and when such tests reveal a failure to meet

specifications, the City of Fairhope will reject the goods and the awarded vendor shall immediately supply goods meeting specifications or the City of Fairhope may seek damages including but not limited to the testing expense, regardless of whether a part of or all of the goods have been consumed through the testing process. Rejected goods shall be removed by the awarded vendor promptly after rejection, at his expense. If not removed in fourteen (14) calendar days, they may be disposed of at the discretion of the City of Fairhope. Disposal costs will be the awarded vendor's responsibility.

### **27. INSPECTION OF PREMISES**

At reasonable times, the City may inspect those areas of the awarded vendor's place of business that are related to the performance of a Contract / Agreement / Purchase Order. If the City makes such an inspection, the awarded vendor must provide reasonable assistance. The City of Fairhope reserves the right on demand and without notice all the vendor's files associated with a subsequent Contract / Agreement / Purchase Order where payments are based on the awarded vendor's record of time, salaries, materials, or actual expenses. This same clause will apply to any sub-contractors assigned to the Contract / Agreement / Purchase Order.

### **28. INSURANCE**

If a Contract / Agreement / Purchase Order results from this RFQ / ITB / RFP, or other form of solicitation, the awarded vendor shall maintain such insurance as will indemnify and hold harmless the City of Fairhope from Workmen's Compensation and Public Liability claims from property damage and personal injury, including death, which may arise from the awarded vendor's operations under this Contract / Agreement / Purchase Order, or by anyone directly or indirectly employed by him/her.

### **29. INVITATION TO BID**

Any provisions made in the RFQ / ITB / RFP, or other form of solicitation, supersedes any provisions outlined here in the General Terms and Conditions.

### **30. INVOICING, DELIVERY, PACKAGING**

Invoices shall be prepared only after ordered materials have been delivered. All invoices must show the purchase order number. Unless otherwise specified in writing, vendors shall not ship any material without an authorized Purchase Order from the City of Fairhope Purchasing Department. All packages delivered must show the purchase order number. The awarded vendor will be required to furnish all materials, equipment and/or service called for at the bid price quoted. In the event the awarded vendor fails to deliver within a reasonable period of time, as determined by the City of Fairhope, the right is reserved to cancel the award and subsequent purchase order and purchase from the next lowest responsible bidder the items needed. The original awarded vendor will be back charged the difference between the original contract price and the price the City of Fairhope has to pay as a result of the failure to perform by the original awarded vendor. All bids will remain firm for acceptance for 60 days from the date of bid opening. Prices shall be net F.O.B., Prepaid and Allow, City of Fairhope chosen site, Baldwin County, Al. The title and risk of loss of the goods will not pass to the City of Fairhope until receipt and acceptance takes place at the F.O.B. point.

### **31. LABELING**

Individual shipping cartons shall be labeled with the name "City of Fairhope", Purchase Order Number, and where applicable, Contract Number, date of manufacture, batch number, storage requirements, conditions, and recommended shelf life. Bidders are encouraged to offer product packaging with recycled content.

### **32. LOSS OR DAMAGE IN TRANSIT**

Delivery by a vendor to a common carrier does not constitute delivery to the City of Fairhope. Any claim for loss or damage incurred during delivery shall be between the vendor and the carrier. The City of Fairhope accepts title only after satisfactory receipt at the delivery point. The City of Fairhope shall note all visible damages on the freight bill and may refuse the damaged goods. The vendor shall make immediate replacement of the damaged merchandise or be subject to damages for breach of contract. If damage is to a small portion of a total shipment and the City of Fairhope will not be inconvenienced because of the shortage, the vendor may be permitted by the Purchasing Manager to deduct the amount of damage or loss from its invoice, in lieu of replacement. Risk of loss during delivery is borne by the vendor until the goods have been accepted by the City of Fairhope, unless otherwise specified in the RFQ / ITB / RFP or other form of solicitation.

### **33. MANDATORY SITE VISIT**

If the RFQ / ITB /RFP or other form of solicitation requires a mandatory site visit, bidders must inspect the site where installation or service is to take place to obtain a full understanding of scope of work outlined therein. Date of site visit will be determined by the City of Fairhope.

### **34. MONITORING OF SERVICES**

Performance of services will be monitored by the requisitioning department and/or the Purchasing Department, and evaluation reports may be filed with the Purchasing Department. Performance not meeting specifications will result in cancellation of Contract / Agreement / Purchase Order and may result in vendor being removed from the vendor list.

### **35. NON-CONFORMING MERCHANDISE**

When merchandise received from the lowest responsible bidder is not in accordance with the purchase order, it will be returned to the bidder, at bidder's expense.

### **36. NON-DESCRIMINATION**

The City of Fairhope is an Equal Opportunity Employer and requires that all CONTRACTORS comply with the Equal Employment Opportunity laws and the provisions of the Contract / Agreement / Purchase Order documents in this regard. The City also encourages and supports the utilization of Minority Business Enterprises on this and all public bids.

### **37. NON-EXCLUSIVE**

Unless otherwise specified, this Contract / Agreement / Purchase Order is considered a non-exclusive Contract /Agreement / Purchase Order between the parties.

### **38. NOTIFICATION AND ACCIDENT REPORTS**

In the event of accidents of any kind, in the performance of a Contract / Agreement / Purchase Order, the awarded vendor shall notify the City of Fairhope immediately and furnish, without delay,

copies of all such accident reports to the City of Fairhope. If in the performance of their Work, the awarded vendor fails to immediately report an accident to the City of Fairhope, of which the awarded vendor has knowledge of and which results in a fine levied against the City of Fairhope then the awarded vendor shall be responsible for all fines levied against the City of Fairhope.

### **39. PACKAGING**

All goods must be packaged in new packing containers. Packing that meets the requirements of common carriers is acceptable, unless otherwise required. A packing slip or invoice must accompany all shipments and must reference the purchase order number. Unless otherwise specified, goods are to be packaged in cartons meeting federal specifications and shipped on non-returnable pallets.

### **40. PATENTS**

Awarded Vendor guarantees that the sale and / or use of goods will not infringe upon any U.S. or foreign patent. Awarded vendor will at his / her own expense, indemnify, protect and save harmless the City of Fairhope, on any patent claims arising from the purchase of goods or services.

### **41. PAYMENT**

Invoices -- Upon completion of service and delivery of materials specified in the applicable purchase order, awarded vendor will submit an invoice and signed delivery ticket to:

City of Fairhope  
Accounts Payable Department  
P.O. Drawer 429  
Fairhope, Al. 36533  
[ap@fairhopeal.gov](mailto:ap@fairhopeal.gov)

All invoices must reference appropriate Purchase Order Numbers  
Payment of Invoice: All invoices received by the City of Fairhope are payable within thirty (30) days from the date of receipt by the City of Fairhope, provided they are approved by the City of Fairhope.

### **42. PAYMENT WITHHELD**

Payment may be withheld until all items have been delivered and all requirements of the Contract / Agreement / Purchase Order have been fulfilled

### **43. PRODUCT TESTING**

Vendor shall incur all cost involved in obtaining an Independent Laboratory Test if the City deems necessary during the term of the Contract / Agreement / Purchase Order. The City of Fairhope reserves the right to request a demonstration of any and all items bid before making the award

### **44. PERMITS LICENSES AND CERTIFICATES**

The awarded vendor is to procure all permits, licenses, and certificates, or any approvals of plans or specifications as may be required by Federal, State, Local Laws, ordinances, rules, and regulations, for the proper execution and completion of Work covered under the Contract / Agreement / Purchase Order.

### **45. PREPARATION OF BID**

All bids / proposals shall be typewritten or in ink on the



form(s) prepared by the City of Fairhope. Bids / proposals prepared in pencil will not be accepted. All bids / proposals must be signed by officials of the corporation or company duly authorized to sign bids / proposals. Any bid / proposal submitted without being signed will automatically be rejected. All corrections or erasures shall be initialed and dated by the person authorized to sign quotations / bids / proposals. If there are discrepancies between unit prices quoted and extensions, the unit price will prevail.

#### **46. QUESTIONS / CONTACT**

Commencing with the issuance of the RFQ / ITB / RFP, or other form of solicitation, no vendor or anyone acting on a vendor's behalf, shall make direct or indirect contact with City personnel or undertake any activities or take any action to otherwise promote its quotation / bid / proposal to the City or its personnel. All communications shall be made to the contact identified in the quotation / bid / proposal documents. Violation of this requirement may, at the City's sole and absolute discretion, be grounds for disqualifying a vendor from further consideration.

#### **47. RECEIPT BY CITY OF FAIRHOPE**

If not otherwise stated in the order, the City of Fairhope will be said to have received goods when they have been delivered, unloaded and placed on the agency's dock or if there is no dock, inside an accessible building, and signed for by an authorized City employee. Shipments will be checked against the receiving copy of the Purchase Order. If the purchase order requires grading certificates, USDA Stamps, or any proof of quality, such proof must accompany the shipment.

#### **48. REJECTION OF BIDS**

The City of Fairhope reserves the right to accept or reject any or all bids in whole or in part for any reason, to waive technicalities or informalities, or to advertise for new proposals, if, in the judgment of the awarding authority, the best interest of the City of Fairhope will be promoted thereby. Bidders may be disqualified and rejection of proposals may be recommended for any of (but not limited to) the following causes: Failure to use the bid forms furnished by the City of Fairhope, Lack of signature by an authorized representative on the bid form, Failure to properly complete the bid form and vendor compliance, Evidence of collusion among bidders, unauthorized alteration of the bid form.

#### **50. RIGHT TO AUDIT**

The awarded vendor shall maintain documentation of all work performed. The awarded vendor shall make any and all documentation available to the City of Fairhope at all reasonable times, for inspections and audit by the City of Fairhope, during the entire term of the Contract / Agreement / Purchase Order and for a period of Three (3) years after expiration of the Contract / Agreement / Purchase Order.

#### **51. SAMPLES**

Bidders will not be required to furnish samples at the time of bid opening, unless specifically called for. The City of Fairhope reserves the right to request samples after bid opening to assist in the evaluation of proposals submitted.

#### **52. SAFETY MEASURES**

The awarded vendor shall take all necessary precautions for the safety of the City of Fairhope's and awarded vendor's employees at the Work site, and shall erect and properly maintain at all

times, all necessary safeguards for the protection of the workmen and the public. The awarded vendor shall post signs warning against hazards in and around the Work site.

#### **53. SET-UP AND INSTALLATION**

Unless otherwise specified, bid / quotation to include cost of all uncrating, disposal of shipping materials, set-up, testing and initial instruction to agency personnel.

#### **54. SPILL CLEAN UP**

The awarded vendor shall be responsible for spillage caused by their negligence, which occurs during transit or unloading operations. The awarded vendor shall immediately report and clean up any spillage. Upon failure to do so, the awarded vendor shall remain responsible for all actual related costs

#### **55. SUBSTITUTIONS**

Substitutions on a purchase order shall require the approval of the Originating Buyer. The City of Fairhope reserves the right to reject at destination and hold at the vendor's risk and expense any goods supplied by the vendor which do not conform to the specification or description embodied in the order or are inferior in any respect to the good specified. Any good bought by sample which is inferior in quality to the sample submitted by vendor will be rejected. Any goods delivered that do not meet specifications may be returned to the vendor at its expense. When a good is returned, the vendor must make immediate replacement with acceptable merchandise or the City of Fairhope may seek remedies for default.

#### **56. TABULATION**

Bid results are posted on The City of Fairhope's web site: [www.fairhopeal.gov](http://www.fairhopeal.gov). The awarded vendor will be sent a written notification via mail.

#### **57. TAXES**

Prices quoted shall be delivered prices, exclusive of all federal or state excise, sales, and manufacturer's taxes. The City will assume no transportation or handling charges other than specified in the RFQ, ITB, RFP or other form of solicitation. The City is tax exempt by law – Code of Alabama 1975.

#### **58. TERMINATION FOR CONVENIENCE**

Any Contract / Agreement / Purchase Order may be terminated for convenience by the City of Fairhope, in whole or in part, by written notification to the awarded vendor.

#### **59. TERMINATION FOR DEFAULT**

Performance of Work under the Contract / Agreement / Purchase Order Agreement may be terminated by the City of Fairhope, in whole or in part, in writing, whenever the City of Fairhope determines that the awarded vendor has failed to meet the requirements of the Contract / Agreement / Purchase Order.

#### **60. TERMINATION FOR NON-APPROPRIATION**

Termination for Non-appropriation – The continuation of any financial obligation beyond the current fiscal year is subject to and contingent upon sufficient funds being appropriated, budgeted, and otherwise made available by the local source, State Legislature and/or federal sources. The City of Fairhope may terminate any financial obligation, and awarded vendor waives any and all claim(s) for damages, effective immediately upon

receipt of written notice (or any date specified therein) if for any reason the City of Fairhope's funding from local, State and/or federal sources is not appropriated, withdrawn or limited.

**61. TIME IS OF THE ESSENCE**

The City of Fairhope and awarded vendor agree that time is of the essence in the performance of work called for under this Contract / Agreement / Purchase Order. The awarded vendor agrees that all work will be accomplished regularly, diligently and uninterrupted at such a rate of progress as will ensure full completion thereof within reasonable time periods.

**62. TITLE**

All titles, fees, as well as other charges, are to be paid by awarded vendor. Awarded vendor is to furnish prepaid certificate of title in the name of the City of Fairhope, Title shall change upon acceptance of delivery at the City of Fairhope approved delivery location.

**63. VENDOR LIST**

A vendor may be removed from the City of Fairhope's Bidders List if a vendor fails to respond to three (3) consecutive ITB's. A properly submitted "No Bid" is considered as a response and the vendor will receive credit for the response.

**64. WARRANTY**

The awarded vendor expressly warrants that all articles, materials, and work offered shall conform to each and every specification, drawing, sample, or other description which is furnished to or adopted by the City of Fairhope, and that it will be fit and sufficient for the purpose intended, merchantable, of good material and workmanship, and free from defects. The awarded vendor further warrants all items for a period of one year, unless otherwise stated, from the date of acceptance of the items delivered and installed or work completed. All repairs, replacements, or adjustments during the warranty period will be at the awarded vendor's sole expense. Awarded vendor will provide written warranty for all parts and labor for a period of (1) one year commencing from date of written acceptance of delivery by City of Fairhope. Awarded vendor will provide written copies of all other applicable warranties, such as, Manufacturer's warranty. Those warranties, if any, will be in addition to the awarded vendor's warranty, and the terms of which will not be altered by the awarded vendor's warranty.

**65. IMMIGRATION LAW**

The CONTRACTOR agrees that it shall comply with all of the requirements of the **Beason-Hammon Alabama Taxpayer and Citizen Protection Act, Act No 2011-535**, Alabama Code (1975) Section 31-13-1, et. Seq., (also known as the Alabama Immigration Act) see Section 31-13-9, and the provisions of said Act, including all penalties for violation thereof, are incorporated herein.

# CONTRACT

## SAMPLE

This **CONTRACT** is made this \_\_\_\_ day of \_\_\_\_\_, 2021 by and between the City of Fairhope (hereinafter "**OWNER**") and \_\_\_\_\_, hereinafter "**CONTRACTOR**"), on the **WORK**:

**BID 030-21 Covered Slip Roof and Framing Repairs at the Docks —FEMA 4563**

**Project # PW012-21 Covered Slip Roof Repairs**

The **OWNER** and **CONTRACTOR** agree as set forth below:

1. The contract consists of all of the items contained within this contract, the bid package, proposal, scope of work, specifications and if any drawings addenda, amendments, Attachments, and "City of Fairhope Standard Terms and Conditions", which are attached hereto and made a part hereof, as if fully contained herein; for the performance of all work and the furnishing of all labor and materials required.
2. The **CONTRACTOR** shall perform all the **WORK** described herein.
3. The **WORK** to be performed under this **CONTRACT** shall be commenced upon execution of this **CONTRACT** within number TEN (10) days of the date specified in the *Notice to Proceed* (NIP) to be issued to the **CONTRACTOR** by the **OWNER**, or its authorized representative. The work shall be completed, subject to authorized adjustments, within **TWENTY-ONE (21) consecutive calendar days** from and after the commencement date stipulated in said *Notice to Proceed*. **Liquidated damages for non-completion of the work within this time limit will be assessed at the rate of \$350 per working day.**
4. The **OWNER** shall pay the **CONTRACTOR** in current funds for the performance of the **WORK**, the **CONTRACT SUM** of \_\_\_\_\_ DOLLARS (\$ \_\_\_\_\_). This represents a **LUMP SUM** payment for performance of the **WORK**, which payment shall be issued after the Contract is fully performed and the **OWNER** has inspected the **WORK**.

### **3.0 GENERAL CONDITIONS**

- 3.01 **Indemnity:** The **CONTRACTOR** hereby agrees to indemnify and save harmless the **OWNER**, its officers, agent, and employees, from and against any and all liabilities, claims, demands, damages, fines, fees, expenses, penalties, suits, proceedings, actions and cost of actions, including reasonable attorneys' fees for trial and on appeal, of any kind and nature, arising or growing out of, or in any way connected with the performance of this Contract, to the extent caused by a negligent act or omission of the **CONTRACTOR**, their agents, servants, employees,
- 3.02 **Notification and Accident Reports:** In the event of accidents of any kind, the **CONTRACTOR** shall notify the **OWNER** immediately and furnish, without delay, copies of all such accident reports to the **OWNER**. If in the performance of their Work, the **CONTRACTOR** fails to immediately report an accident to the **OWNER**, of which the **CONTRACTOR** has knowledge of and which results in a fine levied against the **OWNER** then the **CONTRACTOR** shall be responsible for all fines levied against the **OWNER**.

### **4.0 Termination of Agreement**

- 4.01 **Termination for Default:** Performance of Work under this Agreement may be terminated by the **OWNER**, in whole or in part, in writing, whenever the **OWNER** determines that the **CONTRACTOR** has failed to meet the requirements of this Agreement.
- 4.02 **Termination for Convenience:** In the event that any of the provisions of this contract are violated by the **CONTRACTOR**, or by any of his sub-**CONTRACTORS**, the **OWNER** may serve written notice upon the **CONTRACTOR** and the surety of his intention to terminate the contract,





**NOTARY FOR THE CITY**

STATE OF ALABAMA}  
COUNTY OF BALDWIN}

I, the undersigned authority in and for said State and County, hereby certify that **Sherry Sullivan**, as **Mayor** of the City of Fairhope, whose name is signed to the foregoing document, and who is known to me, acknowledged before me on this day, that, being informed of the contents of the document she executed the same voluntarily on the date the same bears date.

Given under my hand and Notaries Seal on this \_\_\_\_ day of \_\_\_\_\_, 2021.

NOTARY PUBLIC \_\_\_\_\_

MY COMMISSION EXPIRES: \_\_\_\_ / \_\_\_\_ / \_\_\_\_\_

**CONTRACTOR**

**CORPORATION, PARTNERSHIP, OR JOINT VENTURE**

\_\_\_\_\_  
Name of Corporation, Partnership or Joint Venture

BY: \_\_\_\_\_  
(SIGNATURE of Officer authorized for sign Quotes and Contracts for the firm) (Position or Title)

\_\_\_\_\_  
(PRINT name of Officer authorized for sign Quotes and Contracts for the firm)

\_\_\_\_\_  
(PRINT NAME(S) OF OTHERS IF IN PARTNERSHIP)

Business \_\_\_\_\_

Business Mailing Address \_\_\_\_\_

City, State, Zip Code \_\_\_\_\_

Email \_\_\_\_\_

General Contractor's License \_\_\_\_\_ Alabama Foreign Entity ID \_\_\_\_\_

**NOTARY FOR CORPORATION, PARTNERSHIP OR JOINT VENTURE**

STATE OF \_\_\_\_\_ }  
COUNTY OF \_\_\_\_\_ }

I the undersigned authority in and for the said State and County, hereby certify that  
\_\_\_\_\_  
Signature of Bidder and \_\_\_\_\_, as \_\_\_\_\_ and  
Print name of Bidder Title  
\_\_\_\_\_, respectively, of \_\_\_\_\_  
Title Print Company name

whose name(s) is signed to the foregoing document and who is known to me, acknowledged before me on this day, that, being informed of the contents of the document they executed the same voluntarily on the day the same bears date.

Given under my hand and Notary Seal on this \_\_\_\_day of \_\_\_\_\_, 2021.

Notary Public\_\_\_\_\_

My Commission Expires\_\_\_\_\_

## Alabama Immigration Act Contract Requirements

### 1.0 Background

The **Beason-Hammon Alabama Taxpayer and Citizen Protection Act, Act No 2011-535, as amended by Act No 2012-491, Code of Alabama (1975) Section 31-13-1 through Section 31-13-30** (also known as and hereinafter referred to as “the Alabama Immigration Act”) is applicable to contracts with the City of Fairhope, Alabama. All business entities entering into contracts with the City of Fairhope, Alabama will comply with the Alabama Immigration Act.

### 2.0 Definitions

**ALIEN.** Any person who is not a citizen or national of the United States, as described in 8 U.S.C. § 1101, et seq., and any amendments thereto.

**BUSINESS ENTITY.** Any person or group of persons employing one or more persons performing or engaging in any activity, enterprise, profession, or occupation for gain, benefit, advantage, or livelihood, whether for profit or not for profit. Business entity shall include but not be limited to the following:

- a. Self-employed individuals, business entities filling articles of incorporation, partnerships, limited partnerships, limited liability companies, foreign corporations, foreign limited partnerships, foreign liability companies authorized to transact business in this state, business trusts, and any business entity that registers with the Secretary of State.
- b. Any business entity that possesses a business license, permit, certificate, approval, registration, charter, or similar form of authorization issued by the state, any business entity that is exempt by law from obtaining such a business license, an any business entity that is operating unlawfully without a business license.

**CONTRACTOR.** A person, employer, or business entity that enters into an agreement to perform any service or work or to provide a certain product in exchange for valuable consideration. This definition shall include, but not be limited to, a general CONTRACTOR, sub-CONTRACTOR, independent CONTRACTOR, contract employee, project manager, or a recruiting or staffing entity.

**EMPLOYEE.** Any person directed, allowed, or permitted to perform labor or service of any kind by an employer. The employees of an independent CONTRACTOR working for a business entity shall not be regarded as the employees of the business entity, for the purposes of this chapter. This term does not include any inmate in the legal custody of the state, a county, or a municipality.

**EMPLOYER.** Any person, firm, corporation, partnership, joint stock association, agent, manager, representative, foreman, or other person having control or custody of any employment, place of employment, or of any employee, including any person or entity employing any person for hire within the State of Alabama, including a public employer. This term shall not include the occupant of a household contracting with another person to perform casual domestic labor within the household.

**E-VERIFY.** The electronic verification of federal employment authorization program of the Illegal Immigration Reform and Immigrant Responsibility Act of 1996, P.L. 104-208, Division c, Section 403 (a); 8 U.S.C. §1324(a), and operated by the United States Department of Homeland Security, or its successor program.

**STATE-FUNDED ENTITY.** Any governmental entity of the state or a political subdivision thereof or any other entity that receives any monies from the state or a political subdivision thereof; provided, however, an entity that merely provides a service or a product to any governmental entity of the state or a political subdivision thereof, and receives compensation for the same, shall not be considered a state-funded entity.

SUB-CONTRACTOR. A person, business entity, or employer who is awarded a portion of an existing contract by a CONTRACTOR, regardless of its tier.

UNAUTHORIZED ALIEN. An alien who is not authorized to work in the United States as defined in 8 U.S.C. § 1324a (h) (3).

### 3.0 **Mandatory Clause**

All contracts or agreements to which the state, a political subdivision, or state-funded entity are a party shall include the following clause:

***"By signing this contract, the contracting parties affirm, for the duration of the agreement, that they will not violate federal immigration law or knowingly employ, hire for employment, or continue to employ an unauthorized alien within the state of Alabama. Furthermore, a contracting party found to be in violation of this provision shall be deemed in breach of the agreement and shall be responsible for all damages resulting therefrom."***

For purposes of this section, "contract" shall mean a contract awarded by the state, any political subdivision thereof, or any state-funded entity that was competitively Quote or would, if entered into by the state or an agency thereof, be required to be submitted to the Contract Review Permanent Legislative Oversight Committee.

### 4.0 **Contracts Involving Business Entity, or Employer**

As a condition for the award of any contract, grant, or incentive by the state, any political subdivision thereof, or any state-funded entity to a business entity or employer that employs one or more employees, the business entity or employer shall not knowingly employ, hire for employment, or continue to employ an unauthorized alien within the State of Alabama.

As a condition for the award of any contract, grant, or incentive by the state, any political subdivision thereof, or any state-funded entity to a business entity or employer that employs one or more employees within the state of Alabama, **the business entity or employer shall provide documentation establishing that the business entity or employer is enrolled in the E-Verify program.** During the performance of the contract, the business entity or employer shall participate in the E-Verify program and shall verify every employee that is required to be verified according to the applicable federal rules and regulations.

### 5.0 **Contracts Involving Subcontracting**

Any sub-contractor on a project paid for by contract, grant, or incentive by the state, any political subdivision thereof, or any state-funded entity shall not knowingly employ, hire for employment, or continue to employ an unauthorized alien within the State of Alabama and shall also enroll in the E-Verify program prior to performing any work on the project. Furthermore, during the performance of the contract, the sub-contractor shall participate in the E-Verify program and shall verify every employee that is required to be verified according to the applicable federal rules and regulations. This subsection shall only apply to sub-contractors performing work on a project subject to the provisions of this section and not to collateral persons or business entities hired by the sub-contractor.

### 6.0 **Proof of E-Verify** documentation will be in the form of a copy of the signed Memorandum Of Understanding (MOU) generated upon completion of the E-Verify program.

# ADDITIONAL FEMA REQUIRED DOCUMENTS

## **ATTACHMENT B**

### **FEMA FEDERAL CONTRACT PROVISIONS**

#### **A. EQUAL EMPLOYMENT OPPORTUNITY CLAUSE (2 CFR §200.326 Appendix II to Part 200 (C) )**

During the performance of the contract, CONTRACTOR shall comply with the Equal Employment Opportunity Clause (41 CFR 60-1.4(b)):

1. CONTRACTOR will not discriminate against any employee or applicant for employment because of race, color, religion, sex, or national origin. CONTRACTOR will take affirmative action to ensure that applicants are employed, and that employees are treated during employment without regard to their race, color, religion, sex, or national origin. Such action shall include, but not be limited to the following: Employment, upgrading, demotion, or transfer; recruitment or recruitment advertising; layoff or termination; rates of pay or other forms of compensation; and selection for training, including apprenticeship. CONTRACTOR agrees to post in conspicuous places, available to employees and applicants for employment, notices to be provided setting forth the provisions of this nondiscrimination clause.
2. CONTRACTOR will, in all solicitations or advertisements for employees placed by or on behalf of the CONTRACTOR, state that all qualified applicants will receive considerations for employment without regard to race, color, religion, sex, or national origin.
3. CONTRACTOR will send to each labor union or representative of workers with which he has a collective bargaining agreement or other contract or understanding, a notice to be provided advising the said labor union or workers' representatives of the CONTRACTOR's commitments under this section, and shall post copies of the notice in conspicuous places available to employees and applicants for employment.
4. CONTRACTOR will comply with all provisions of Executive Order 11246 of September 24, 1965, and of the rules, regulations, and relevant orders of the Secretary of Labor.
5. CONTRACTOR will furnish all information and reports required by Executive Order 11246 of September 24, 1965, and by rules, regulations, and orders of the Secretary of Labor for purpose of investigation to ascertain compliance with such rules, regulations, and orders.
6. In the event of the CONTRACTOR's noncompliance with the nondiscrimination clauses of this Contract or with any of the said rules, regulations or orders, this contract may be canceled, terminated, or suspended in whole or in part and the CONTRACTOR may be declared ineligible for further Government contracts or federally assisted construction contracts in accordance with procedures authorized in Executive Order 11246 of September 24, 1965, and such other sanctions may be imposed and remedies invoked as provided in Executive Order 11246 of September 24, 1965, or by rule, regulation, or order of the Secretary of Labor, or as otherwise provided by law.
7. CONTRACTOR will include the portion of the sentence immediately preceding paragraph 1 and the provisions of paragraph 1 through 7 in every subcontract or purchase order unless exempted by rules, regulations, or orders of the Secretary of Labor issued pursuant to section 204 of Executive Order 11246 of September 24, 1965, so that such provisions will be binding upon each subcontractor or vendor. The CONTRACTOR will take such action with respect to any subcontract or purchase order as the administering agency may direct as a means of enforcing such provisions, including sanctions for noncompliance: provided, however, that in the event a CONTRACTOR becomes involved in, or is threatened with, litigation with a subcontractor or vendor as a result of such direction by the administering agency the CONTRACTOR may request the United States to enter into such litigation to protect the interest of the United States.

**B. DAVIS-BACON ACT (2 CFR §200.326 Appendix II to Part 200 (D))**

(Not applicable to this Contract; applicable only for prime construction contracts in excess of \$2,000.) CONTRACTOR shall pay wages to laborers and mechanics at a rate not less than those in the attached Davis-Bacon Act Wage Rate Table(s) as made by the Secretary of Labor. CONTRACTOR shall pay wages not less than once per week.

**C. COPELAND "ANTI-KICKBACK" ACT (2 CFR §200.326 Appendix II to Part 200 (D))**

(Not applicable to this Contract; applicable only for prime construction contracts in excess of \$2,000.) CONTRACTOR shall comply with the Copeland "Anti-Kickback" Act (40 U.S.C. §3145), as supplemented by Department of Labor regulations (29 CFR Part 3, "Contractors and Subcontractors on Public Building or Public Work Financed in Whole or in Part by Loans or Grants from the United States"). The Act provides that the CONTRACTOR and COUNTY is prohibited from inducing, by any means, any person employed in the construction, completion, or repair of public work, to give up any part of the compensation to which he or she is otherwise entitled. The COUNTY must report all suspected or reported violations to the appropriate Federal agency.

1. *CONTRACTOR. The CONTRACTOR shall comply with 18 U.S.C. § 874, 40 U.S. C. § 3145, and the requirements of 29 C.F.R. pt. 3 as may be applicable, which are incorporated by reference into this Contract.*
2. *Subcontracts. The CONTRACTOR or subcontractor shall insert in any subcontracts the clause above and such other clauses as the FEMA may by appropriate instructions require, and also a clause requiring the subcontractors to include these clauses in any lower tier subcontracts. The prime CONTRACTOR shall be responsible for the compliance by any subcontractor or lower tier subcontractor with all of these contract clauses.*
3. *Breach. A breach of the contract clause above may be grounds for termination of the Contract, and for debarment as a contractor and subcontractor as provided in 29 C.F.R. §5.12.*

**D. CONTRACT WORK HOURS AND SAFETY STANDARDS ACT (2 CFR §200.326 Appendix II to Part 200 (E)) (40 U.S.C. 3701-3708)**

(Not applicable to the purchases of supplies or materials or articles ordinarily available on the open market, or contracts for transportation or transmission of intelligence.) Contracts in excess of \$100,000 that involve the employment of mechanics or laborers shall comply with 40 U.S.C. 3702 and 3704, as supplemented by Department of Labor regulations (29 CFR Part 5). Under 40 U.S.C. 3702 of the Act, each CONTRACTOR and its subcontractors shall compute the wages of every mechanic and laborer on the basis of a standard workweek of 40 hours. Work in excess of the standard workweek is permissible provided that the worker is compensated at a rate of not less than one and a half times the basic rate of pay for all hours worked in excess of 40 hours in the workweek. The requirements of 40 U.S.C. 3704 are applicable to construction work and provide that no laborer or mechanic must be required to work in surroundings or under working conditions, which are unsanitary, hazardous or dangerous.

**E. RIGHTS TO INVENTIONS MADE UNDER A CONTRACT OR AGREEMENT (2 CFR §200.326 Appendix II to Part 200 (F))**

(Not applicable to this Contract.) If the Federal award meets the definition of "funding agreement" under 37 CFR §401.2 (a) and the recipient or subrecipient wishes to enter into a contract with a small business firm or nonprofit organization regarding the substitution of parties, assignment or performance of experimental, developmental, or research work under that "funding agreement," the recipient or subrecipient must comply with the requirements of 37 CFR Part 401, "Rights to Inventions Made by Nonprofit Organizations and Small Business." Firms under Government Grants, Contracts and Cooperative Agreements," and any implementing regulations issued by the awarding agency.



- F. CLEAN AIR ACT AND FEDERAL WATER POLLUTION CONTROL ACT (2 CFR §200.326 Appendix II to Part 200 (G))**  
CONTRACTOR shall comply with all applicable standards, orders or regulations issued pursuant to the Clean Air Act (42 U.S.C. 7401-7671q.) and the Federal Water Pollution Control Act as amended (33 U.S.C. 1251-1387). Violations must be reported to the Federal awarding agency and the Regional Office of the Environmental Protection Agency (EPA).
- G. DEBARMENT AND SUSPENSION (2 CFR §200.326 Appendix II to Part 200 (H))**  
A contract cannot be awarded to parties listed on the government-wide exclusions in the System for Award Management (SAM), in accordance with the OMB guidelines at 2 CFR 180 that implement Executive Orders 12549 (3 CFR part 1986 Comp., p. 189) and 12689 (3 CFR part 1989 Comp., p. 235), "Debarment and Suspension." The Excluded Parties List System in SAM contains the names of parties debarred, suspended, or otherwise excluded by agencies, as well as parties declared ineligible under statutory or regulatory authority other than Executive Order 12549. The Vendor/CONTRACTOR agrees to comply with the requirements of 2 C.F.R. pt. 180, subpart C and 2 C.F.R. pt. 3000, subpart C while this offer is valid and throughout the period of any contract that may arise from this offer. The Vendor/CONTRACTOR further agrees to include a provision requiring such compliance in its lower tier covered transactions.
- H. PROCUREMENT OF RECOVERED MATERIALS (2 CFR §200.322)**  
CONTRACTOR must comply with Section 6002 of the Solid Waste Disposal Act, as amended by the Resource Conservation and Recovery Act. The requirements of Section 6002 include procuring only items designated in guidelines of the Environmental Protection Agency (EPA) at 40 CFR part 247 that contain the highest percentage of recovered materials practicable, consistent with maintaining a satisfactory level of competition, where the purchase price of the item exceeds \$10,000 or the value of the quantity acquired by the preceding fiscal year exceeded \$10,000; procuring solid waste management services in a manner that maximizes energy and resource recovery; and establishing an affirmative procurement program for procurement of recovered materials identified in the EPA guidelines.
- I. CONTRACTING WITH SMALL AND MINORITY BUSINESSES, WOMEN'S BUSINESS ENTERPRISES, AND LABOR SURPLUS AREA FIRMS (2 CFR §200.321)**  
Should the CONTRACTOR subcontract any of the work under this Contract, CONTRACTOR shall take the following affirmative steps: place qualified small and minority businesses and women's business enterprises on solicitation lists; assure that small and minority businesses, and women's business enterprises are solicited whenever they are potential sources; divide total requirements, when economically feasible, into smaller tasks or quantities to permit maximum participation by small and minority businesses, and women's business enterprises; establish delivery schedules, where the requirement permits, which encourage participation by small and minority businesses, and women's business enterprises; and use the services and assistance, as appropriate, of such organizations as the Small Business Administration and the Minority Business Development Agency of the Department of Commerce. Their websites and contact information can be found at [www.SBA.gov](http://www.SBA.gov) and [www.MBDA.gov](http://www.MBDA.gov).
- J. ENERGY EFFICIENCY AND CONSERVATION**  
CONTRACTOR shall comply with the mandatory standards and policies of the Florida Energy Efficiency and Conservation Act issued in compliance with the Energy Policy and Conservation Act (42 U.S.C. § 6201).

## ***TERMINATION FOR DEFAULT***

The City of Fairhope reserves the right to enforce the performance of this contract in any manner prescribed by law or deemed to be in the best interest of the City in the event of breach or default of this contract. City of Fairhope reserves the right to terminate the **contract** immediately in the event the successful proposer fails to:

- ◆ meet delivery or completion schedules
- ◆ otherwise perform in accordance with the accepted proposal

Breach of contract or default authorizes the City to award to another proposer, purchase elsewhere, and charge the full increase in cost to the defaulting proposer.

## ***NON-PERFORMANCE CONDITION***

If the product or service is not in conformance with the specifications and requirements of the City, the vendor shall redo and complete any work necessary, bring the product or service into compliance at the vendor's expense.

CERTIFICATION REGARDING LOBBYING

The undersigned certifies, to the best of his or her knowledge and belief, that:

(1) No Federal appropriated funds have been paid or will be paid, by or on behalf of the undersigned, to any person for influencing or attempting to influence an officer or employee of any agency, a Member of Congress, an officer or employee of Congress, or an employee of a Member of Congress in connection with the awarding of any Federal grant, the making of any Federal loan, the entering into of any cooperative agreement, and the extension, continuation, renewal, amendment or modification of any Federal contract, grant, loan, or cooperative agreement.

(2) If any funds other than Federal appropriated funds have been paid or will be paid to any person for influencing or attempting to influence an officer or employee of any agency, a Member of Congress, an officer or employee of Congress, or an employee of a Member of Congress in connection with this Federal contract, grant, loan, or cooperative agreement, the undersigned shall complete and submit Standard Form-LLL, "Disclosure of Lobbying Activities," in accordance with its instructions.

(3) The undersigned shall require that the language of this certification be included in the award documents of all sub-awards at all tiers (including subcontracts, sub-grants, and contracts under grants, loans, and cooperative agreements) and that all subrecipients shall certify and disclose accordingly.

This certification is a material representation of fact upon which reliance was placed when this transaction was made or entered into. Submission of this certification is a prerequisite for making or entering into this transaction imposed by section 1352, title 31, United States Code. Any person who fails to file the required certification shall be subject to a civil penalty of not less than \$10,000 and not more than \$100,000 for each such failure.

Organization: \_\_\_\_\_

Street address: \_\_\_\_\_

City, State, Zip: \_\_\_\_\_

CERTIFIED BY:(type or print) \_\_\_\_\_

TITLE: \_\_\_\_\_

\_\_\_\_\_ **(signature)** **(date)**