

**CITY OF FAIRHOPE
CITY COUNCIL WORK SESSION AGENDA**

MONDAY, 14 JUNE 2021 – 4:30 P.M. – COUNCIL CHAMBER

1. Discussion of Replacement of a 90-Ton Chiller at the Fairhope Public Library – George Ladd (Assistant Public Works Director)
2. Discussion of the Second Floor Buildout for the Fairhope Public Library
3. Committee Updates
4. Department Head Updates

**City Council Agenda Meeting - 5:30 p.m.
on Monday, June 14, 2021 – Council Chambers**

Next Regular Meeting – June 28, 2021 - Same Time and Place



Proposal

Gulf Coast Common Branch
764B LAKESIDE DR
MOBILE, AL 36693-5114
Phone: 866-607-6878
Fax: 866-867-3608

TO: City of Fairhope
501 Fairhope Ave.
Fairhope, AL

Date: June 4, 2021
Project: Fairhope Public Library Chiller
Change Out

Richard Johnson

Executive Summary:

Johnson Controls is pleased to have the opportunity to propose this project. Johnson Controls was asked to provide a turn-key solution for replacing an existing 90 ton Trane Air Cooled Chiller. The existing chiller is having issues with the coil being in poor condition and the compressors failing. This is leading to high head pressure which causes the chiller to shut down and not perform to its capabilities and creates higher repair cost.

The new York or Trane chiller will have separate controls built into them. However, in the near future, it is our recommendation to upgrade the controls on the overall library for an overall view of the HVAC equipment at the library and potentially the whole city. **The controls upgrade with remote monitoring capability would allow a Johnson Controls certified technician to diagnose and view any alarms directly from their smartphone device. This would drastically eliminate or reduce any down time on any equipment.**

Using the buying influence, NCPA, we propose this project with two different prices based on which chiller is chosen by the customer to install. This presents two options between a York 90T Air

Cooled Chiller, and a Trane 90T Air Cooled Chiller. Both options are like for like replacements but the York chiller would require a little more piping. The NCPA contract number can be given at the time of award.

Scope of Work:

Johnson Controls will execute this project during the week at normal labor rates. Johnson

Controls will provide the following materials and execute the following:

- 90T Air Cooled York Chiller, 90T Air Cooled Trane Chiller- Options given for customer preference- **All chiller options are high efficiency and with coated coils. Also, chillers are all priced with 10 year parts and labor warranty.**
- Crane with spreader bar for hoisting and rigging
- Piping for new chiller
- Butterfly Valves
- Insulation of new chiller piping

Electrical connections are expected to be like for like, therefore there is no cost built in for an electrician. If, connections are not like for like and an electrician is required, Johnson Controls will contract this trade with a change order.

The existing controls to the existing chiller will function with the new chiller. A chiller upgrade is recommended at a different cost or project. A controls upgrade with remote monitoring would give Johnson Controls the ability to diagnose and view the chillers using their smart device. **The technician could view any alarms and prepare for any necessary repairs prior to making a site visit.**

Project Pricing:

- **Option 1: 90T York Air Cooled Chiller- \$88,125.25**
 - **Model- YLAA0092**
 - **Priced with Louvered Panels and Isolation Valves**
 - **10 Year Warranty on Parts and Labor**
 - **Refrigerant Warrant Included- 18 Months**
 - **MCHX Warranty: 66 Months (5 Year) (Parts Only)**
 - **BACnet Connectivity**

- **Option 2: 90T Trane Air Cooled Chiller- \$131,565.51**
 - **Model- CGAM90**
 - **Priced with Louvered Panels and Isolation Valves**
 - **10 Year Warranty on Parts and Labor**
 - **1 Year Refrigerant Warrant**

Project Documents:



Design Conditions Datasheet

Unit Tag	Qty	Model No	Net Cooling Capacity (ton.R)	Nominal Voltage	Refrigerant Type
CH-1	1	YLAA0092HE46XFBSXTX	85.71	460-3-60.0	R410A

PIN:

YLAA0092HE	46XFBSXTXA	SXBLXCXX44	SXXXXXHXXX	YAXGPXX7XX	XXXNXXXXXX			
...5...10	...5...20	...5...30	...5...40	...5...50	...5...60	...5...70	...5...80	...5...90

Evaporator Data		Evaporator Data (Cont.)		Performance Data	
EWT (°F)	54.00	Fluid Volume (USGAL)	8.771	EER (Btu/W-h)	10.98
LWT (°F)	44.00	Min. Flow Rate (USGPM)	99.86	IPLV.IP (Btu/W-h)	16.79
Design Flow Rate (USGPM)	204.6	Max. Flow Rate (USGPM)	400.1		
Evap. Press. Drop (ft H2O)	7.30				
Fluid	Water	Condenser Data		Physical Data	
Strainer Press. Drop (ft H2O)	4.04	Ambient Temp. Design (°F)	95.0	Rigging Wt. (lb)	5227
Ext. Kit Press. Drop (ft H2O)	2.29	Altitude (ft)	0.000	Operating Wt. (lb)	5300
Total Press. Drop (ft H2O)	13.6	Compressor Type	Scroll - Hermetic	Refrigerant Charge (lb)	103.8
Fouling Factor (h.ft².F/Btu)	0.000100				

Electrical Data

	1	2	3	4
Circuit				
Compressor RLA	27 / 27 / 27	27 / 27 / 27		
Fan QTY/FLA (each)	3 / 4	3 / 4		
High LRA Current	180 / 180 / 180	180 / 180 / 180		

Single Point

Min. Circuit Ampacity	196		
Recommended Fuse/CB Rating	200		
Max. Inverse Time CB Rating	200		
Max. Dual Element Fuse Size (A)	200		
Unit Short Circuit Withstand (STD)	5 [kA]		
Wires Per Phase	1		
Wire Range (Lug Size)	#6 AWG - 500 kcmil		
Starter Type	Across The Line		

Operating Condition Electrical Data	
Compressor kW	83.62
Total Fan kW	10.08
Total kW	93.70

Notes:

Certified in accordance with the AHRI Air-Cooled Water-Chilling Packages Using Vapor Compression Cycle Certification Program, which is based on AHRI Standard 550/590 (I-P) and AHRI Standard 551/591 (SI). Certified units may be found in the AHRI Directory at www.ahridirectory.org. Auxiliary components included in total kW - Oil heaters, Chiller controls. Auxiliary power is already included in the compressor and fan power



ASHRAE Standard 90.1-2010 and ASHRAE Standard 90.1-2013 & 2016 Compliant.

Compliant with the requirements of the LEED Energy and Atmosphere Enhanced Refrigerant Management Credit (EAc4).



Design Conditions Datasheet

Part Load Rating Data				
Stage	Ambient (°F)	Capacity (ton.R)	Total kW	Unit Efficiency (Btu/W·h)
1	95.0	85.71	93.70	10.98
2	87.4	74.86	70.12	12.81
3	78.9	62.68	51.13	14.71
4	69.1	48.73	34.39	17.00
5	58.3	33.25	19.99	19.96
6	55.0	16.29	9.402	20.79

Sound Power Levels (In Accordance with AHRI 370)										
Stage	Ambient (°F)	63 Hz (dB)	125 Hz (dB)	250 Hz (dB)	500 Hz (dB)	1 kHz (dB)	2 kHz (dB)	4 kHz (dB)	8 kHz (dB)	LWA
1	95.0	98	97	93	93	89	88	83	79	95
2	87.4	97	96	92	92	88	87	82	78	94
3	78.9	96	95	91	91	87	86	81	77	93
4	69.1	95	94	90	90	86	84	80	76	92
5	58.3	93	92	88	88	84	83	78	74	90
6	55.0	90	89	85	85	81	80	75	71	87

Note: Unit is equipped with Low Sound Fans.

Measurement of sound pressure used to obtain the sound power data presented is based on AHRI-370.

Air-cooled chillers are rated in terms of sound power not sound pressure. Johnson Controls provides estimates of sound pressure, but this is not the rating metric.

For an air-cooled chiller, sound pressure calculated from sound power varies depending on how the chiller is assumed to behave, i.e. the radiation model. In other words, determining sound pressure from sound power requires making assumptions that result in different answers at a given distance from the chiller. The environment also influences sound pressure in the field installation. Sound pressure estimation radiation models pertaining to air-cooled chillers include the 'traditional' hemispherical model, parallelepiped model and equivalent hemispherical model.

Regarding sound power, Johnson Controls references tolerance limits based on ASHRAE guidelines. These are +/- 6dB in the 63Hz octave band, +/- 4dB in all other octave bands and +/- 3dB for the overall dBA.

Tolerance limits are based on uncertainties associated with:

1. Measurement Test Procedure
2. Repeatability
3. Production / Manufacturing Variability

Standard deviation associated with air-cooled chiller sound data is a measure of spread i.e. it indicates the range of probability of sound levels. Note that for operating conditions other than AHRI's Standard Rating Condition, higher levels of uncertainty can be expected.

Lead times for factory performance testing depend on test laboratory availability. Please confirm with Johnson Controls Customer Service.

Performance at AHRI Conditions					
Evaporator Data		Condenser Data		Performance Data	
EWT (°F)	54.00	Ambient Temp. (°F)	95.0	EER (Btu/W·h)	10.98
LWT (°F)	44.00	Altitude (ft)	0.000	IPLV, IP (Btu/W·h)	16.79
Flow Rate (USGPM)	204.6			Net Cooling Capacity (ton.R)	85.71
Pressure Drop (ft H2O)	7.30				
Fluid	Water				
Fouling Factor (h.ft².F/Btu)	0.000100				
Fluid Volume (USGAL)	8.771				

Note: Unit rated at design condition capacity.

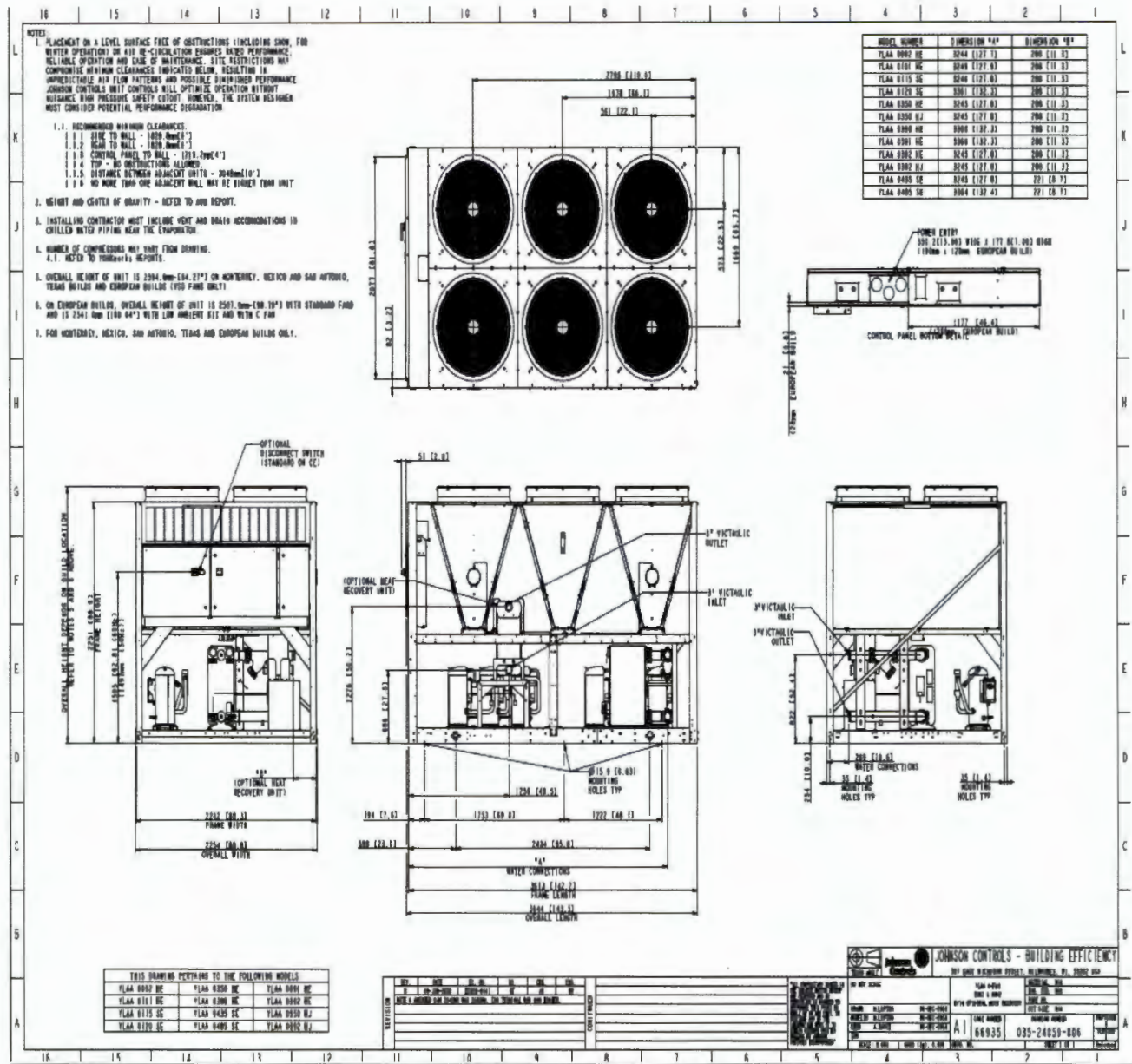



Tag: CGAM-90 MTO
Quantity: 1

INLET/OUTLET WATER
CONNECTION SIZE

4" (100mm)

BRAZE PLATE
WATER VOLUME/STORAGE

9.0 GAL (34.1 LITERS)

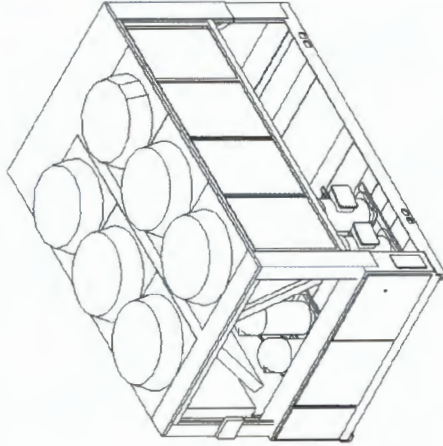

ISOMETRIC VIEW

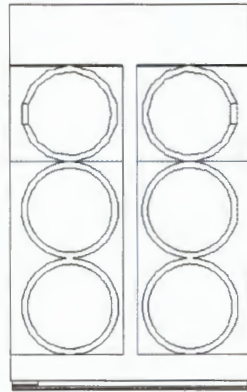

TOP VIEW

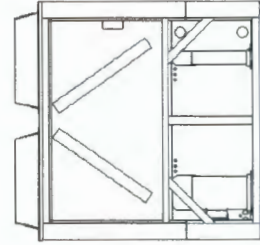

BACK VIEW

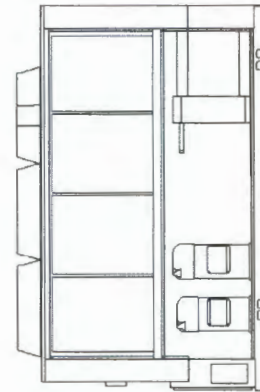

RIGHT SIDE VIEW

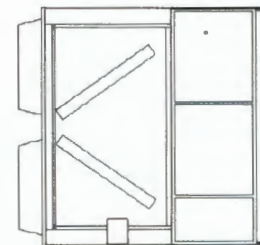

FRONT VIEW

Exclusions and Clarifications:

- Electrical is to be like for like, if not, a change order for an electrician would be required
- Schedule for work is during normal working hours- Monday-Thursday 10 Hour Days
- NCPA Buying Group is being used to propose project
- Permits not included

This proposal and alternates listed below are hereby accepted and Johnson Controls is authorized to proceed with work; subject, however to credit approval by Johnson Controls, Inc., Milwaukee, Wisconsin.

This proposal is valid until: July 5, 2021

Fairhope Public Library

Johnson Controls, Inc.

Name: _____

Name: _____

Title: _____

Title: _____

Date: _____

Date: _____

PO: _____

TERMS AND CONDITIONS

By accepting this proposal, Purchaser agrees to be bound by the following terms and conditions:

1. **SCOPE OF WORK.** This proposal is based upon the use of straight time labor only. Plastering, patching and painting are excluded. "In-line" duct and piping devices, including, but not limited to, valves, dampers, humidifiers, wells, taps, flow meters, orifices, etc., if required hereunder to be furnished by Johnson Controls, Inc. (hereinafter referred to as JCI), shall be distributed and installed by others under JCI's supervision but at no additional cost to JCI. Purchaser agrees to provide JCI with required field utilities (electricity, toilets, drinking water, project hoist, elevator service, etc.) without charge. JCI agrees to keep the job site clean of debris arising out of its own operations. Purchaser shall not back charge JCI for any costs or expenses without JCI's written consent unless specifically noted in the statement of the scope of work or services undertaken by JCI under this agreement, JCI's obligations under this agreement expressly exclude any work or service of any nature associated or connected with the identification, abatement, clean up, control, removal, or disposal of environment Hazards or dangerous substances, to include but not be limited to asbestos or PCSs, discovered in or on the premises. Any language or provision of the agreement elsewhere contained which may authorize or empower the Purchaser to change, modify, or alter the scope of work or services to be performed by JCI shall not operate to compel JCI to perform any work relating to Hazards without JCI's express written consent.
2. **INVOICING && PAYMENTS.** JCI may invoice Purchaser monthly for all materials delivered to the job site or to an off-site storage facility and for all work performed on-site and off-site. Ten percent (10%) of the contract price is for engineering, drafting and other mobilization costs incurred prior to installation. This 10% shall be included in JCI's initial invoice. Purchaser agrees to pay JCI the amount invoiced upon receipt of the invoice. Waivers of lien will be furnished upon request as the work progresses to the extent payments are received. If JCI's invoice is not paid within 30 days of its issuance, it is delinquent.
3. **MATERIALS.** If the materials or equipment included in this proposal become temporarily or permanently unavailable for reasons beyond the control and without the fault of JCI, then in the case of such temporary unavailability, the time for performance of the work shall be extended to the extent thereof, and in the case of permanent unavailability, JCI shall (a) be excused from furnishing said materials or equipment, and (b) be reimbursed for the difference between the cost of the materials or equipment permanently unavailable and the cost of a reasonably available substitute therefore.
4. **WARRANTY.** JCI warrants that the equipment manufactured by it shall be free from defects in material and workmanship arising from normal usage for a period of ninety (90) days from delivery of said equipment, or if installed by JCI, for a period of ninety (90) days from installation. JCI warrants that for equipment furnished and/or installed but not manufactured by JCI, JCI will extend the same warranty terms and conditions which JCI receives from the manufacturer of said equipment. For equipment installed by JCI, if Purchaser provides written notice to JCI of any such defect within thirty (30) days after the appearance or discovery of such defect, JCI shall, at its option, repair or replace the defective equipment. For equipment not installed by JCI, if Purchaser returns the defective equipment to JCI within thirty (30) days after appearance or discovery of such defect, JCI shall, at its option, repair or replace the defective equipment and return said equipment to Purchaser. All transportation charges incurred in connection with the warranty for equipment not installed by JCI shall be borne by Purchaser. These warranties do not extend to any equipment which has been repaired by others, abused, altered or misused, or which has not been properly and reasonably maintained. THESE WARRANTIES ARE IN LIEU OF ALL OTHER WARRANTIES, EXPRESS OR IMPLIED, INCLUDING, BUT NOT LIMITED TO, THOSE OF MERCHANTABILITY AND FITNESS FOR A SPECIFIC PURPOSE
5. **LIABILITY.** JCI shall not be liable for any special, indirect or consequential damages arising in any manner from the equipment or material furnished or the work performed pursuant to this agreement.
6. **TAXES.** The price of this proposal does not include duties, sales, use, excise, or other similar taxes, unless required by federal, state or local law. In addition to the stated price, purchaser shall pay all taxes not legally required to be paid by JCI or, alternatively, shall provide JCI with acceptable tax exemption certificates. JCI shall provide Purchaser with any tax payment certificate upon request and after completion and acceptance of the work.
7. **DELAYS.** JCI shall not be liable for any delay in the performance of the work resulting from or attributed to acts or circumstances beyond JCI's control, including, but not limited to, acts of God, fire, riots, labor disputes, conditions of the premises, acts or omissions of the Purchaser, Owner or other Contractors or delays caused by suppliers or subcontractors of JCI, etc.
8. **SCHEDULE.** JCI and Purchaser shall mutually agree upon a schedule for completion of the work. In the event Purchaser desires to change or accelerate the schedule or the schedule is otherwise accelerated, delayed, or impacted for reasons beyond the control of JCI, JCI shall be entitled to a change order equitably adjusting the compensation of JCI to account for the increased costs associated with such schedule changes.
9. **DISPUTES.** All disputes involving more than \$15,000 shall be resolved by arbitration in accordance with the rules of the American Arbitration Association. The prevailing party shall recover all legal costs and attorney's fees incurred as a result. Nothing here shall limit any rights under construction lien laws.
10. **INSURANCE.** Insurance coverage in excess of JCI's standard limits will be furnished when requested and required. No credit will be given or premium paid by JCI for insurance afforded by others.

11. INDEMNITY. The Parties hereto agree to indemnify each other from any and all liabilities, claims, expenses, losses or damages, including attorneys' fees, which may arise in connection with the execution of the work herein specified and which are caused, in whole or in part, by the negligent act or omission of the Indemnifying Party.

12. OCCUPATIONAL SAFETY AND HEALTH. The Parties hereto agree to notify each other immediately upon becoming aware of an inspection under, or any alleged violation of, the Occupational Safety and Health Act relating in any way to the project or project site.

13. LEGAL FEES. Purchaser agrees to pay and reimburse JCI for any and all reasonable legal fees which are incurred by JCI in the collection of amounts due and payable under this Agreement.

14. ENTIRE AGREEMENT. This proposal, upon acceptance, shall constitute the entire agreement between the parties and supersedes any prior representations or understandings.

15. CHANGES. No change or modification of any of the terms and conditions stated herein shall be binding upon Johnson unless accepted by Johnson in writing.



Fairhope Library Chiller Replacement & Controls Upgrade



Controls Proposal For:
City of Fairhope Public Library
555 South Section Street
FAIRHOPE, AL 36532 U.S.A.

Local Trane Office:
Trane U.S. Inc. dba Trane

Local Trane Representative:
Evan Helinski
Account Manager
Cell: (251) 285-9844

Proposal ID: 2864914

US Communities Contract # USC 15-JLP-023
US Communities Quote # 18-362255-20-008

Date: April 16, 2021



Prepared For:
Fairhope Public Library

Date:
April 16, 2021

Job Name:
Fairhope Library Chiller Replacement & Controls Upgrade

Proposal Number: 2864914

Delivery Terms:
Freight Allowed and Prepaid – F.O.B Factory

Payment Terms:
Net 30

State Contractor License Number:

Proposal Expiration Date:
30 Days

Chiller Installation Scope of Work

After a recent service call, Trane diagnosed a defective screw compressor on the existing RTAA 90 Ton Air-Cooled Chiller serving the Fairhope Public Library. The existing machine also has corroded condenser coils due to the close proximity of the Mobile Bay and Gulf of Mexico. Due to this machine being at the end of its useful life and the high cost of repairs, it is advised to replace this chiller with a new machine.

Trane recommends a new 90 Ton Air-Cooled Chiller with factory coated condenser coils and an extended warranty option for up to 10 years. Please see the scope of work and equipment list below for your review. Thank you for the opportunity to work together.

Item	Tag(s)	Qty	Description	Model Number
A1	CGAM-90 M TO	1	90 Ton Air-Cooled (CGAM)	CGAM090F2**2AXD2A1A1A1DXXA1A1A2XXXXXA1A3A1D1X-L-X

- Air-Cooled Scroll Packaged Chiller
- Startup Included - Trane Service must start equipment for warranty to be honored
- 60 hertz 460 volt 3 phases
- High efficiency/performance
- Full factory refrigerant charge (HFC-410A)
- With factory installed freeze protection
- Refrigerant isolation valves (discharge valve)
- ASHRAE 90.1 all versions up to 2016
- AHRI certified
- Factory installed flow switch - set point 60 cm/sec
- Grooved pipe connection
- Factory insulation 0.75"
- Wide ambient (0 to 125F/-18 to 52C)
- Single point connection main line unit power-ancillary items require other power
- Elastomeric isolators
- With water strainer factory installed
- Super quiet
- Hail Guards
- Trane Communication Interface
- Factory Condenser Coil Coating
- 10 Year Parts Warranty
- 1 Year Labor Warranty
- 1 Year Refrigerant Warranty



Turnkey Installation of HVAC Equipment

- LOTO Existing RTAA Air-Cooled Chiller
- Isolate Chiller with Existing Chilled Water Isolation Valves (Assumed to be in working condition)
- Recover Refrigerant from Existing Refrigerant Circuits
- Disconnect Electrical from Chiller
- Set-up Crane in Library Parking Lot
- Demo Existing Chiller
- Set New Air-Cooled Chiller on in enclosed chiller plant
- Run New Chilled Water from the Rear of the CGAM Air-Cooled Chiller to the Existing Isolation Valves
- Insulate New Chilled Water Lines with Jacketing
- Reconnect Electrical to Field Installed Disconnect Switch
- Reconnect Communication Wiring
- Integrate Chiller to Trane Tracer Summit Controls System
- Remove LOTO
- Start-up Chiller and Verify Proper Operation

Existing Chiller Isolation Valves and Pumping





Controls Scope of Work

The goal of the controls portion of this project is to reduce the overall energy consumption at the Fairhope Public Library. This energy project will consist of optimizing both the air side and water side HVAC systems. Trane will implement OA (Outside Air) optimization strategies, variable speed chilled water pumping and an upgraded building automation system (BAS).

The controls upgrade will include a web-based platform to replace the existing "Tracer Summit BCU" (Building Control Unit) to the latest version of Trane controls "Tracer SC+". All controllers located on HVAC equipment will be integrated and recommissioned to be most cost effective.

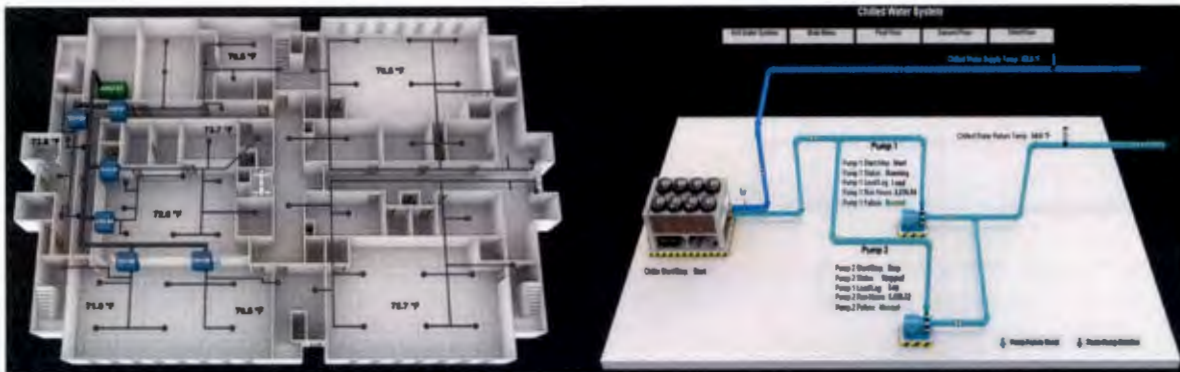

The following existing equipment and controls will be installed:

- **Tracer SC+ Web-Based System Controller**
 - o Retrofit the existing Tracer Summit BCU with a web-based Tracer SC+ System Controller
 - o Render 3-D floor plan graphics based on the existing mechanical plans. This will also include graphical 3-D images of the HVAC equipment being controlled
 - o Install new OA wet bulb / dry bulb combination sensor and integrate to BAS
- **Chiller Plant Controllers (Variable Speed Pumping)**
 - o Upgrade the existing RTAA air-cooled chiller controllers to LonTalk and integrate to the newly installed Tracer SC+ system
 - o Furnish and Install new outdoor rated NEMA 3R VFDs on the existing chilled water pumps.
 - o Integrate the VFD and pumping controls to existing MP580 controller
 - This will allow us to program the system to vary the chilled water flow based on demand to save on excessive pumping energy
- **Air Handling Units (OA Optimization)**
 - o Integrate existing MP580 controllers to Tracer SC+
 - Install (6) Ebron Air Flow Measuring Stations
 - Install (6) CO2 Duct Mounted Sensors
 - Install (6) Modulating OA Damper Actuators
 - o Terminate new sensors and end devices to associated AHU MP580 controller
 - o Program system for "Demand Control Ventilation" optimization strategy to ventilate based on CO2 PPM readings.
- **VAV Integration & Recommissioning**
 - o Integrate (36) existing VAV controllers to Tracer SC+
 - o Recommission VAV boxes for proper electric reheat use
 - o Verify proper control in coordination with air handling units



- **Energy Meter Validation**
 - o Install (2) "Smart Meters" on both the chiller plant switch gear and main library switch gear
 - o Integrate Energy Meters to Tracer SC+
 - o Set up "Tracer Pro Support" to trend data and identify future energy opportunities

Controls systems services included

- Project Management
- Engineered Control Submittals and As-Built Drawings
- Control Panel(s) and Low Voltage Wiring installation
- Control System Programming & Graphics
- Control System Commissioning
- Owner Control System Operational Training – (xx) hour

Controls systems services not included

- Demolition/removal or replacement of existing devices/sensors quoted as "assumed" to be in working condition
- Any temporary controls
- Repair or replacement of any equipment being controlled
- **All controls being integrated are assumed to be in working condition. If any of these controllers are found to be defective, a separate quote shall be provided to make the necessary repairs to these controllers.**

Proposal Notes/ Clarifications

- All work to be performed during normal business hours (8am to 5pm, M-F, non-holidays)
- Proposal does not include "Premium Time" or Price Contingency therefor
- Equipment Order Release and Services rendered are dependent on receipt of PO/Subcontract and credit approval
- Controls for any systems not listed above are excluded
- Trane will not perform any work if working conditions could endanger or put at risk the safety of our employees or subcontractors



Pricing and Acceptance

Fairhope Public Library
Fairhope City of
555 South Section Street
FAIRHOPE, AL 36532 U.S.A.

Site Address:
Fairhope Public Library
501 Fairhope Avenue
FAIRHOPE, AL 36532
United States

Price

Chiller Total Price (10 Year parts/1 year labor/1 year refrigerant warranty).....	\$ 125,799.00
• Add: 2-10 Year Extended Labor Warranty.....	\$ 14,289.00
• Add: 2-10 Year Refrigerant Warranty.....	\$ 1,097.00
 Controls Total Price.....	 \$ 76,062.00
 Grand Total w/ Extended Warranties.....	 <u>\$ 217,247.00</u>

Financial items not included

- Permits
- Bid Bond
- Payment and Performance Bond
- Liquidated Damages
- Demurrage or Storage Charges
- Participation in OCIOP or CCIP Insurance Programs

Respectfully submitted,

Evan Helinski
Account Manager
Trane U.S. Inc. dba Trane
(251) 285-9844



ACCEPTANCE

This proposal is subject to Customer's acceptance of the attached Trane Terms and Conditions (Installation).

We value the confidence you have placed in Trane and look forward to working with you.

Submitted By: Evan T Helinski	Cell: (251) 285-9844
CUSTOMER ACCEPTANCE	Proposal Date: April 16, 2021
Fairhope City of	TRANE ACCEPTANCE
Authorized Representative	Trane U.S. Inc. dba Trane
Printed Name	Authorized Representative
Title	Printed Name
Purchase Order	Title
Acceptance Date:	Signature Date
	License Number:



TERMS AND CONDITIONS – COMMERCIAL INSTALLATION

"Company" shall mean Trane U.S. Inc. dba Trane.

1. **Acceptance; Agreement.** These terms and conditions are an integral part of Company's offer and form the basis of any agreement (the "Agreement") resulting from Company's proposal (the "Proposal") for the commercial goods and/or services described (the "Work"). COMPANY'S TERMS AND CONDITIONS ARE SUBJECT TO PERIODIC CHANGE OR AMENDMENT. The Proposal is subject to acceptance in writing by the party to whom this offer is made or an authorized agent ("Customer") delivered to Company within 30 days from the date of the Proposal. If Customer accepts the Proposal by placing an order, without the addition of any other terms and conditions of sale or any other modification, Customer's order shall be deemed acceptance of the Proposal subject to Company's terms and conditions. If Customer's order is expressly conditioned upon Company's acceptance or assent to terms and/or conditions other than those expressed herein, return of such order by Company with Company's terms and conditions attached or referenced serves as Company's notice of objection to Customer's terms and as Company's counter-offer to provide Work in accordance with the Proposal and the Company terms and conditions. If Customer does not reject or object in writing to Company within 10 days, Company's counter-offer will be deemed accepted. Customer's acceptance of the Work by Company will in any event constitute an acceptance by Customer of Company's terms and conditions. This Agreement is subject to credit approval by Company. Upon disapproval of credit, Company may delay or suspend performance or, at its option, renegotiate prices and/or terms and conditions with Customer. If Company and Customer are unable to agree on such revisions, this Agreement shall be cancelled without any liability, other than Customer's obligation to pay for Work rendered by Company to the date of cancellation.
2. **Pricing and Taxes.** Unless otherwise noted, the price in the Proposal includes standard ground transportation and, if required by law, all sales, consumer, use and similar taxes legally enacted as of the date hereof for equipment and material installed by Company. Tax exemption is contingent upon Customer furnishing appropriate certificates evidencing Customer's tax exempt status. Company shall charge Customer additional costs for bonds agreed to be provided. Equipment sold on an uninstalled basis and any taxable labor/labour do not include sales tax and taxes will be added. Following acceptance without addition of any other terms and condition of sale or any other modification by Customer, the prices stated are firm provided that notification of release for immediate production and shipment is received at the factory not later than 3 months from order receipt. If such release is received later than 3 months from order receipt date, prices will be increased a straight 1% (not compounded) for each one-month period (or part thereof) beyond the 3 month firm price period up to the date of receipt of such release. If such release is not received within 6 months after date of order receipt, the prices are subject to renegotiation, or at Company's option, the order will be cancelled. Any delay in shipment caused by Customer's actions will subject prices to increase equal to the percentage increase in list prices during that period of delay and Company may charge Customer with incurred storage fees.
3. **Exclusions from Work.** Company's obligation is limited to the Work as defined and does not include any modifications to the Work site under the Americans With Disabilities Act or any other law or building code(s). In no event shall Company be required to perform work Company reasonably believes is outside of the defined Work without a written change order signed by Customer and Company.
4. **Performance.** Company shall perform the Work in accordance with industry standards generally applicable in the area under similar circumstances as of the time Company performs the Work. Company may refuse to perform any Work where working conditions could endanger property or put at risk the safety of persons. Unless otherwise agreed to by Customer and Company, at Customer's expense and before the Work begins, Customer will provide any necessary access platforms, catwalks to safely perform the Work in compliance with OSHA or state industrial safety regulations.
5. **Payment.** Customer shall pay Company's invoices within net 30 days of invoice date. Company may invoice Customer for all equipment or material furnished, whether delivered to the installation site or to an off-site storage facility and for all Work performed on-site or off-site. No retention shall be withheld from any payments except as expressly agreed in writing by Company, in which case retention shall be reduced per the contract documents and released no later than the date of substantial completion. Under no circumstances shall any retention be withheld for the equipment portion of the order. If payment is not received as required, Company may suspend performance and the time for completion shall be extended for a reasonable period of time not less than the period of suspension. Customer shall be liable to Company for all reasonable shutdown, standby and start-up costs as a result of the suspension. Company reserves the right to add to any account outstanding for more than 30 days a service charge equal to 1.5% of the principal amount due at the end of each month. Customer shall pay all costs (including attorneys' fees) incurred by Company in attempting to collect amounts due and otherwise enforcing these terms and conditions. If requested, Company will provide appropriate lien waivers upon receipt of payment. Customer agrees that, unless Customer makes payment in advance, Company will have a purchase money security interest in all equipment from Company to secure payment in full of all amounts due Company and its order for the equipment, together with these terms and conditions, form a security agreement. Customer shall keep the equipment free of all taxes and encumbrances, shall not remove the equipment from its original installation point and shall not assign or transfer any interest in the equipment until all payments due Company have been made.
6. **Time for Completion.** Except to the extent otherwise expressly agreed in writing signed by an authorized representative of Company, all dates provided by Company or its representatives for commencement, progress or completion are estimates only. While Company shall use commercially reasonable efforts to meet such estimated dates, Company shall not be responsible for any damages for its failure to do so.
7. **Access.** Company and its subcontractors shall be provided access to the Work site during regular business hours, or such other hours as may be requested by Company and acceptable to the Work site' owner or tenant for the performance of the Work, including sufficient areas for staging, mobilization, and storage. Company's access to correct any emergency condition shall not be restricted. Customer grants to Company the right to remotely connect (via phone modem, internet or other agreed upon means) to Customer's building automation system (BAS) and or HVAC equipment to view, extract, or otherwise collect and retain data from the BAS, HVAC equipment, or other building systems, and to diagnose and remotely make repairs at Customer's request.
8. **Completion.** Notwithstanding any other term or condition herein, when Company informs Customer that the Work has been completed, Customer shall inspect the Work in the presence of Company's representative, and Customer shall either (a) accept the Work in its entirety in writing, or (b) accept the Work in part and specifically identify, in writing, any exception items. Customer agrees to re-inspect any and all excepted items as soon as Company informs Customer that all such excepted items have been completed. The initial acceptance inspection shall take place within ten (10) days from the date when Company informs Customer that the Work has been completed. Any subsequent re-inspection of excepted items shall take place within five (5) days from the date when Company informs Customer that the excepted items have been completed. Customer's failure to cooperate and complete any of said inspections within the required time limits shall constitute complete acceptance of the Work as of ten (10) days from date when Company informs Customer that the Work, or the excepted items, if applicable, has/have been completed.
9. **Permits and Governmental Fees.** Company shall secure (with Customer's assistance) and pay for building and other permits and governmental fees, licenses, and inspections necessary for proper performance and completion of the Work which are legally required when bids from Company's subcontractors are received, negotiations thereon concluded, or the effective date of a relevant Change Order, whichever is later. Customer is responsible for necessary approvals, easements, assessments and charges for construction, use or occupancy of permanent structures or for permanent changes to existing facilities. If the cost of such permits, fees, licenses and inspections are not included in the Proposal, Company will invoice Customer for such costs.
10. **Utilities During Construction.** Customer shall provide without charge to Company all water, heat, and utilities required for performance of the Work.
11. **Concealed or Unknown Conditions.** In the performance of the Work, if Company encounters conditions at the Work site that are (i) subsurface or otherwise concealed physical conditions that differ materially from those indicated on drawings expressly incorporated herein or (ii) unknown physical conditions of an unusual nature that differ materially from those conditions ordinarily found to exist and generally recognized as inherent in construction activities of the type and character as the Work, Company shall notify Customer of such conditions promptly, prior to significantly disturbing same. If such conditions differ materially and cause an increase in Company's cost of, or time required for, performance of any part of the Work, Company shall be entitled to, and Customer shall consent by Change Order to, an equitable adjustment in the Contract Price, contract time, or both.
12. **Pre-Existing Conditions.** Company is not liable for any claims, damages, losses, or expenses, arising from or related to conditions that existed in, on, or upon the Work site before the Commencement Date of this Agreement ("Pre-Existing Conditions"), including, without limitation, damages, losses, or expenses involving Pre-Existing Conditions of building envelope issues, mechanical issues, plumbing issues, and/or indoor air quality issues involving mold/mould and/or



fungi. Company also is not liable for any claims, damages, losses, or expenses, arising from or related to work done by or services provided by individuals or entities that are not employed by or hired by Company.

13. Asbestos and Hazardous Materials. Company's Work and other services in connection with this Agreement expressly excludes any identification, abatement, cleanup, control, disposal, removal or other work connected with asbestos, polychlorinated biphenyl ("PCB"), or other hazardous materials (hereinafter, collectively, "Hazardous Materials"). Customer warrants and represents that, except as set forth in a writing signed by Company, there are no Hazardous Materials on the Work site that will in any way affect Company's Work and Customer has disclosed to Company the existence and location of any Hazardous Materials in all areas within which Company will be performing the Work. Should Company become aware of or suspect the presence of Hazardous Materials, Company may immediately stop work in the affected area and shall notify Customer. Customer will be exclusively responsible for taking any and all action necessary to correct the condition in accordance with all applicable laws and regulations. Customer shall be exclusively responsible for and, to the fullest extent permitted by law, shall indemnify and hold harmless Company (including its employees, agents and subcontractors) from and against any loss, claim, liability, fees, penalties, injury (including death) or liability of any nature, and the payment thereof arising out of or relating to any Hazardous Materials on or about the Work site, not brought onto the Work site by Company. Company shall be required to resume performance of the Work in the affected area only in the absence of Hazardous Materials or when the affected area has been rendered harmless. In no event shall Company be obligated to transport or handle Hazardous Materials, provide any notices to any governmental agency, or examine the Work site for the presence of Hazardous Materials.

14. Force Majeure. Company's duty to perform under this Agreement is contingent upon the non-occurrence of an Event of Force Majeure. If Company shall be unable to carry out any material obligation under this Agreement due to an Event of Force Majeure, this Agreement shall at Company's election (i) remain in effect but Company's obligations shall be suspended until the uncontrollable event terminates or (ii) be terminated upon 10 days notice to Customer, in which event Customer shall pay Company for all parts of the Work furnished to the date of termination. An "Event of Force Majeure" shall mean any cause or event beyond the control of Company. Without limiting the foregoing, "Event of Force Majeure" includes: acts of God; acts of terrorism, war or the public enemy; flood; earthquake; tornado; storm; fire; civil disobedience; pandemic insurrections; riots; labor/labour disputes; labor/labour or material shortages; sabotage; restraint by court order or public authority (whether valid or invalid), and action or non-action by or inability to obtain or keep in force the necessary governmental authorizations, permits, licenses, certificates or approvals if not caused by Company, and the requirements of any applicable government in any manner that diverts either the material or the finished product to the direct or indirect benefit of the government.

15. Customer's Breach. Each of the following events or conditions shall constitute a breach by Customer and shall give Company the right, without an election of remedies, to terminate this Agreement or suspend performance by delivery of written notice: (1) Any failure by Customer to pay amounts when due; or (2) any general assignment by Customer for the benefit of its creditors, or if Customer becomes bankrupt or insolvent or takes the benefit of any statute for bankrupt or insolvent debtors, or makes or proposes to make any proposal or arrangement with creditors, or if any steps are taken for the winding up or other termination of Customer or the liquidation of its assets, or if a trustee, receiver, or similar person is appointed over any of the assets or interests of Customer; (3) Any representation or warranty furnished by Customer in this Agreement is false or misleading in any material respect when made; or (4) Any failure by Customer to perform or comply with any material provision of this Agreement. Customer shall be liable to Company for all Work furnished to date and all damages sustained by Company (including lost profit and overhead).

16. Indemnity. To the fullest extent permitted by law, Company and Customer shall indemnify, defend and hold harmless each other from any and all claims, actions, costs, expenses, damages and liabilities, including reasonable attorneys' fees, resulting from death or bodily injury or damage to real or tangible personal property, to the extent caused by the negligence or misconduct of their respective employees or other authorized agents in connection with their activities within the scope of this Agreement. Neither party shall indemnify the other against claims, damages, expenses or liabilities to the extent attributable to the acts or omissions of the other party. If the parties are both at fault, the obligation to indemnify shall be proportional to their relative fault. The duty to indemnify will continue in full force and effect, notwithstanding the expiration or early termination hereof, with respect to any claims based on facts or conditions that occurred prior to expiration or termination.

17. Limitation of Liability. NOTWITHSTANDING ANYTHING TO THE CONTRARY, IN NO EVENT SHALL COMPANY BE LIABLE FOR ANY SPECIAL, INCIDENTAL, INDIRECT CONSEQUENTIAL, OR PUNITIVE OR EXEMPLARY DAMAGES (INCLUDING WITHOUT LIMITATION BUSINESS INTERRUPTION, LOST DATA, LOST REVENUE, LOST PROFITS, LOST DOLLAR SAVINGS, OR LOST ENERGY USE SAVINGS, EVEN IF A PARTY HAS BEEN ADVISED OF SUCH POSSIBLE DAMAGES OR IF SAME WERE REASONABLY FORESEEABLE AND REGARDLESS OF WHETHER THE CAUSE OF ACTION IS FRAMED IN CONTRACT, NEGLIGENCE, ANY OTHER TORT, WARRANTY, STRICT LIABILITY, OR PRODUCT LIABILITY). In no event will Company's liability in connection with the provision of products or services or otherwise under this Agreement exceed the entire amount paid to Company by Customer under this Agreement.

18. Patent Indemnity. Company shall protect and indemnify Customer from and against all claims, damages, judgments and loss arising from infringement or alleged infringement of any United States patent by any of the goods manufactured by Company and delivered hereunder, provided that in the event of suit or threat of suit for patent infringement, Company shall promptly be notified and given full opportunity to negotiate a settlement. Company does not warrant against infringement by reason of Customer's design of the articles or the use thereof in combination with other materials or in the operation of any process. In the event of litigation, Customer agrees to reasonably cooperate with Company. In connection with any proceeding under the provisions of this Section, all parties concerned shall be entitled to be represented by counsel at their own expense.

19. Limited Warranty. Company warrants for a period of 12 months from the date of substantial completion ("Warranty Period") commercial equipment manufactured and installed by Company against failure due to defects in material and manufacture and that the labor/labour furnished is warranted to have been properly performed (the "Limited Warranty"). Trane equipment sold on an uninstalled basis is warranted in accordance with Company's standard warranty for supplied equipment. **Product manufactured by Company that includes required startup and is sold in North America will not be warranted by Company unless Company performs the product start-up.** Substantial completion shall be the earlier of the date that the Work is sufficiently complete so that the Work can be utilized for its intended use or the date that Customer receives beneficial use of the Work. If such defect is discovered within the Warranty Period, Company will correct the defect or furnish replacement equipment (or, at its option, parts therefor) and, if said equipment was installed pursuant hereto, labor/labour associated with the replacement of parts or equipment not conforming to this Limited Warranty. Defects must be reported to Company within the Warranty Period. Exclusions from this Limited Warranty include damage or failure arising from: wear and tear; corrosion, erosion, deterioration; Customer's failure to follow the Company-provided maintenance plan; refrigerant not supplied by Trane; and modifications made by others to Company's equipment.

Company shall not be obligated to pay for the cost of loss or infringement. Notwithstanding the foregoing, all warranties provided herein terminate upon termination or cancellation of this Agreement. No warranty liability whatsoever shall attach to Company until the Work has been paid for in full and then said liability shall be limited to the lesser of Company's cost to correct the defective Work and/or the purchase price of the equipment shown to be defective. Equipment, material and/or parts that are not manufactured by Company are not warranted by Company and have such warranties as may be extended by the respective manufacturer. THE WARRANTY AND LIABILITY SET FORTH IN THIS AGREEMENT ARE IN LIEU OF ALL OTHER WARRANTIES AND LIABILITIES, WHETHER IN CONTRACT OR IN NEGLIGENCE, EXPRESS OR IMPLIED, IN LAW OR IN FACT, INCLUDING IMPLIED WARRANTIES OF MERCHANTABILITY AND FITNESS FOR A PARTICULAR PURPOSE AND/OR OTHERS ARISING FROM COURSE OF DEALING OR TRADE. COMPANY MAKES NO REPRESENTATION OR WARRANTY, EXPRESS OR IMPLIED REGARDING PREVENTION BY THE WORK, OR ANY COMPONENT THEREOF, OF MOLD/MOULD, FUNGUS, BACTERIA, MICROBIAL GROWTH, OR ANY OTHER CONTAMINATES. COMPANY SPECIFICALLY DISCLAIMS ANY LIABILITY IF THE WORK OR ANY COMPONENT THEREOF IS USED TO PREVENT OR INHIBIT THE GROWTH OF SUCH MATERIALS.

20. Insurance. Company agrees to maintain the following insurance while the Work is being performed with limits not less than shown below and will, upon request from Customer, provide a Certificate of evidencing the following coverage:

Commercial General Liability	\$2,000,000 per occurrence
Automobile Liability	\$2,000,000 CSL
Workers Compensation	Statutory Limits



If Customer has requested to be named as an additional insured under Company's insurance policy, Company will do so but only subject to Company's manuscript additional insured endorsement under its primary Commercial General Liability policies. In no event does Company waive its right of subrogation.

21. Commencement of Statutory Limitation Period. Except as to warranty claims, as may be applicable, any applicable statutes of limitation for acts or failures to act shall commence to run, and any alleged cause of action stemming therefrom shall be deemed to have accrued, in any and all events not later than the last date that Company or its subcontractors physically performed work on the project site.

22. General. Except as provided below, to the maximum extent provided by law, this Agreement is made and shall be interpreted and enforced in accordance with the laws of the state or province in which the Work is performed, without regard to choice of law principles which might otherwise call for the application of a different state's or province's law. Any dispute arising under or relating to this Agreement that is not disposed of by agreement shall be decided by litigation in a court of competent jurisdiction located in the state or province in which the Work is performed. Any action or suit arising out of or related to this Agreement must be commenced within one year after the cause of action has accrued. To the extent the Work site is owned and/or operated by any agency of the Federal Government, determination of any substantive issue of law shall be according to the Federal common law of Government contracts as enunciated and applied by Federal judicial bodies and boards of contract appeals of the Federal Government. This Agreement contains all of the agreements, representations and understandings of the parties and supersedes all previous understandings, commitments or agreements, oral or written, related to the subject matter hereof. This Agreement may not be amended, modified or terminated except by a writing signed by the parties hereto. No documents shall be incorporated herein by reference except to the extent Company is a signatory thereon. If any term or condition of this Agreement is invalid, illegal or incapable of being enforced by any rule of law, all other terms and conditions of this Agreement will nevertheless remain in full force and effect as long as the economic or legal substance of the transaction contemplated hereby is not affected in a manner adverse to any party hereto. Customer may not assign, transfer, or convey this Agreement, or any part hereof, or its right, title or interest herein, without the written consent of the Company. Subject to the foregoing, this Agreement shall be binding upon and inure to the benefit of Customer's permitted successors and assigns. This Agreement may be executed in several counterparts, each of which when executed shall be deemed to be an original, but all together shall constitute but one and the same Agreement. A fully executed facsimile copy hereof or the several counterparts shall suffice as an original.

23. Equal Employment Opportunity/Affirmative Action Clause. Company is a federal contractor that complies fully with Executive Order 11246, as amended, and the applicable regulations contained in 41 C.F.R. Parts 60-1 through 60-60, 29 U.S.C. Section 793 and the applicable regulations contained in 41 C.F.R. Part 60-741; and 38 U.S.C. Section 4212 and the applicable regulations contained in 41 C.F.R. Part 60-250 Executive Order 13496 and Section 29 CFR 471, appendix A to subpart A, regarding the notice of employee rights in the United States and with Canadian Charter of Rights and Freedoms Schedule B to the Canada Act 1982 (U.K.) 1982, c. 11 and applicable Provincial Human Rights Codes and employment law in Canada.

24. U.S. Government Work.

The following provision applies only to direct sales by Company to the US Government. The Parties acknowledge that all items or services ordered and delivered under this Agreement are Commercial Items as defined under Part 12 of the Federal Acquisition Regulation (FAR). In particular, Company agrees to be bound only by those Federal contracting clauses that apply to "commercial" suppliers and that are contained in FAR 52.212-5(e)(1). Company complies with 52.219-8 or 52.219-9 in its service and installation contracting business.

The following provision applies only to indirect sales by Company to the US Government. As a Commercial Item Subcontractor, Company accepts only the following mandatory flow down provisions in effect as of the date of this subcontract: 52.203-19; 52.204-21; 52.204-23; 52.219-8; 52.222-21; 52.222-26; 52.222-35; 52.222-36; 52.222-50; 52.225-26; 52.247-64. If the Work is in connection with a U.S. Government contract, Customer certifies that it has provided and will provide current, accurate, and complete information, representations and certifications to all government officials, including but not limited to the contracting officer and officials of the Small Business Administration, on all matters related to the prime contract, including but not limited to all aspects of its ownership, eligibility, and performance. Anything herein notwithstanding, Company will have no obligations to Customer unless and until Customer provides Company with a true, correct and complete executed copy of the prime contract. Upon request, Customer will provide copies to Company of all requested written communications with any government official related to the prime contract prior to or concurrent with the execution thereof, including but not limited to any communications related to Customer's ownership, eligibility or performance of the prime contract. Customer will obtain written authorization and approval from Company prior to providing any government official any information about Company's performance of the work that is the subject of the Proposal or this Agreement, other than the Proposal or this Agreement.

25. Limited Waiver of Sovereign Immunity. If Customer is an Indian tribe (in the U.S.) or a First Nation or Band Council (in Canada), Customer, whether acting in its capacity as a government, governmental entity, a duly organized corporate entity or otherwise, for itself and for its agents, successors, and assigns: (1) hereby provides this limited waiver of its sovereign immunity as to any damages, claims, lawsuit, or cause of action (herein "Action") brought against Customer by Company and arising or alleged to arise out of the furnishing by Company of any product or service under this Agreement, whether such Action is based in contract, tort, strict liability, civil liability or any other legal theory; (2) agrees that jurisdiction and venue for any such Action shall be proper and valid (a) if Customer is in the U.S., in any state or United States court located in the state in which Company is performing this Agreement or (b) if Customer is in Canada, in the superior court of the province or territory in which the work was performed; (3) expressly consents to such Action, and waives any objection to jurisdiction or venue; (4) waives any requirement of exhaustion of tribal court or administrative remedies for any Action arising out of or related to this Agreement; and (5) expressly acknowledges and agrees that Company is not subject to the jurisdiction of Customer's tribal court or any similar tribal forum, that Customer will not bring any action against Company in tribal court, and that Customer will not avail itself of any ruling or direction of the tribal court permitting or directing it to suspend its payment or other obligations under this Agreement. The individual signing on behalf of Customer warrants and represents that such individual is duly authorized to provide this waiver and enter into this Agreement and that this Agreement constitutes the valid and legally binding obligation of Customer, enforceable in accordance with its terms.

1-26.251-10(1019)
Supersedes 1-26.251-10(0315)

**CITY OF FAIRHOPE
CITY COUNCIL AGENDA**

MONDAY, 14 JUNE 2021 - 6:00 P.M. - CITY COUNCIL CHAMBER

Invocation and Pledge of Allegiance

1. Approve minutes of 24 May 2021 Regular City Council Meeting, minutes of 24 May 2021 Work Session, and minutes of 24 May 2021 Agenda Meeting.
2. Police Promotions – Chief Stephanie Hollinghead
3. Report of the Mayor
4. Public Participation – Agenda Items – (3 minutes maximum)
5. Council Comments
6. **Public Hearing** – Ordinance – Amend Zoning Ordinance No. 1253.
Request to zone the property of Roberta U. Harris, Stephen J. Urbanek, and Margaret U. Dunnam to Planned Unit Development (PUD) concurrent with annexation into the City of Fairhope. The property generally located southeast corner of the intersection of County Road 48 and Blueberry Lane, Fairhope, Alabama. PPIN Number: 43640. The property to be known as Overland PUD.
7. **Final Adoption** – An Ordinance to Approve an Application from Coca Cola Bottling Company United for a Franchise Agreement to operate Beverage Vending Machines at the locations specified in Bid No. 006-21, Beverage Vending and Concessions 2021; and it is to be in the best interest of the public and the City of Fairhope to grant this franchise. (Introduced at the May 24, 2021 City Council Meeting)
8. **Final Adoption** – An Ordinance Directing the Transfer and Declaring certain real property as surplus and not needed for public or municipal purposes located at the intersection of County Road 13 and County Road 32 Improvement; 05-46-08-33-0-000-009.000: Tract Number 1; containing 0.210 acres, more or less to Baldwin County, Alabama to be used as part of construction of a roundabout at said intersection which will serve a public purpose allowing easier ingress and egress to the City’s future sports fields and increase traffic safety at said intersection. (Introduced at the May 24, 2021 City Council Meeting)
9. Ordinance – An Ordinance of the City of Fairhope repealing and replacing Section 21-21, Code of Ordinances, by the adoption of the following Electric Rates for all Customers of the City.
10. Resolution – That the City Council authorizes Mayor Sherry Sullivan to execute the American Recue Plan Act Agreement between the City of Fairhope and the United States Department of the Treasury for the Coronavirus State and Local Fiscal Recovery Funds in the amount of \$1,941,458.00 to be used in compliance with section 603(c) of the Social Security Act, Treasury’s regulations implementing that section, and guidance issued by Treasury regarding the foregoing.

11. Resolution – That the proposed Certificate of Amendment is hereby approved for the Fairhope Airport Authority under the provisions of the Title 4, Chapter 3, Article 2, Code of Alabama, 1975.
12. Resolution – That the City Council approves the selection of Kimley-Horn to perform Professional Consulting Services for the New Water Transmission Line on County Road 33 (RFQ No. PS014-21); and hereby authorizes Mayor Sherry Sullivan to negotiate a fee schedule and establish a not-to-exceed limit with this firm.
13. Resolution – That the City Council approves the selection of Stewart Engineering, Inc. to perform Professional Engineering Services for System Study for the Electric Department (RFQ No. PS012-21); and hereby authorizes Mayor Sherry Sullivan to negotiate a fee schedule and establish a not-to-exceed limit with this firm.
14. Resolution – That the City of Fairhope hereby Rejects RFQ No. 013-21 for N. Beach Pavilion Repair and Replacement of Asphalt Shingle Roof – FEMA 4563 that was damaged by Hurricane Sally for the Public Works Department due to the excessive price of the only one response; and authorizes Staff to seek informal quotes.
15. Resolution – That Mayor Sherry Sullivan is hereby authorized to execute a contract with Vision Technology Solutions, LLC d/b/a Vision Internet Providers to perform Professional Services for Website Design and Management (RFQ No. PS017-21) with a not-to-exceed amount of \$11,205.81.
16. Resolution – That Mayor Sherry Sullivan is hereby authorized to execute a contract with S.E. Civil, LLC to perform Professional Engineering Services for Water Main Replacement at SR 181 along ROW to CR 34 for the Water Department (RFQ No. PS024-21) with a not-to-exceed amount of \$23,500.00.
17. Resolution – To Award Bid for Materials for Masonry and Concrete Work for ADA Compliance Project at Fairhope Municipal Stadium for the Recreation Department (Bid No. 028-21) to Bay Steel Corporation with a total cost of \$22,274.00.
18. Resolution – To Award Bid for Materials for New Scoreboard-Video Message Board for Fairhope Municipal Stadium for the Recreation Department (Bid No. 026-21) to Electro-Mech with a total cost of \$226,940.00. The Fairhope High School has committed \$176,000.00 to be paid over a five-year period in participation with the City of Fairhope.
19. Resolution – To Award Bid for Nix Center Repair/Replace Asphalt Roof Shingles – FEMA 4563 for Community Affairs Department. (Bid No. 022-21) to VON Electric General Contractors, LLC with a total cost of \$120,000.00.
20. Resolution – To Award Bid for City-Wide Concrete Work, Curbing, ADA Ramps, Inlets, and Structures for the Public Works Department and Utilities (Bid No. 018-21) to Parten Smith, Inc. with a bid proposal for the unit amounts shown in the attached bid tabulation.
21. Resolution – To Award Bid for Six Overhead Doors for Fire Station #3 for the Fairhope Volunteer Fire Department (Bid No. 014-21) to Bailey Door, Inc. with a total bid proposal of \$40,038.00.

22. Resolution – To Award RFQ for the procurement to Reshape/Rebuild Greens on Holes #6 and #11 of Quail Creek Golf Course Sur-Line Turf, Inc. with a total approximate cost of \$21,080.00.
23. Resolution – That the City of Fairhope has voted to purchase a 2021 F250 Crew Cab 4x4 Pickup Truck with Utility Body for the Water Department; and the type of vehicle needed is on the Alabama State Department of Purchasing bid list and therefore does not have to be let out for bid with a cost of \$41,450.00.
24. Resolution – That the City of Fairhope has voted to purchase a 2021 F250 Super Cab Extended 4x2 Pickup Truck with Service Body for the Water Department; and the type of vehicle needed is on the Alabama State Department of Purchasing bid list and therefore does not have to be let out for bid with a cost of \$38,824.00.
25. Resolution – That the City of Fairhope approves the request from Sarah Fischer, Site Director of Prism United Fairhope, to hold a Chalk Event on the sidewalks in South Beach Park on Saturday, June 25, 2021 from 5:00 p.m. to 8:00 p.m.; and to put up a table to provide information about its program, distribute flyers and buttons, and provide chalk and water. Prism United Fairhope is dedicated to serving the needs of the LGBTQ+ youth of Fairhope and the surrounding areas.
26. Resolution – That the City of Fairhope has voted to purchase a 2022 F350 Crew Cab 4x4 DWR Pickup Truck for the Fairhope Volunteer Fire Department; and the type of vehicle needed is on the Alabama State Department of Purchasing bid list and therefore does not have to be let out for bid with a cost of \$48,272.00. This will be a procurement using Impact Fees.
27. Resolution – That the City of Fairhope has voted to procure a Replacement Chiller Unit for the Fairhope Public Library with a 90T York Air Cooled Chiller; and the equipment is available for direct procurement through the NCPA Cooperative which has been nationally bid; and therefore, does not have to be let out for bid with a cost of \$88,125.25.
28. Appointment – Parking Authority – Chad Bartz
29. Write off Customer Terminated Balances as of June 1, 2021 for Balances prior to fiscal year ending 2019 in the amount of \$614,485.95.
30. Public Participation – (3 minutes maximum)
31. Adjourn

**City Council Work Session - 4:30 p.m.
on Monday, June 14, 2021 – Council Chambers**

**City Council Agenda Meeting - 5:30 p.m.
on Monday, June 14, 2021 – Council Chambers**

Next Regular Meeting – Monday, June 28, 2021 - Same Time and Place

STATE OF ALABAMA)(
 :
COUNTY OF BALDWIN)(

The City Council, City of Fairhope, met in regular session at 6:00 p.m., Fairhope Municipal Complex Council Chamber, 161 North Section Street, Fairhope, Alabama 36532, on Monday, 24 May 2021.

Present were Council President Pro Tempore Jimmy Conyers, Councilmembers: Corey Martin, Jay Robinson, and Kevin Boone, Mayor Sherry Sullivan, City Attorney Marcus E. McDowell, and City Clerk Lisa A. Hanks. Council President Jack Burrell was absent.

There being a quorum present, Council President Pro Tempore Conyers called the meeting to order. The invocation was given by Pastor Jason Garcia of Celebration Church and the Pledge of Allegiance was recited.

Council President Pro Tempore Conyers announced that the Public Hearing for the Overland PUD zoning case will be held on June, 14, 2021 at 6:00 p.m.

Council President Pro Tempore Conyers stated there was a need to add on two agenda items after Agenda Item Number 21: appointments of Knox McMurphy and May-Moss Parker to the Tree Committee; and a resolution that the City Council of the City of Fairhope hereby officially declares an emergency as an electrical panel needing to be replaced and moved due to the panel overheating and jeopardizing the power to part of the building and the testing lab at the City of Fairhope’s Wastewater Treatment Plant Building; authorizes Mayor Sherry Sullivan to hire a certified electrician to assess the damage; and to appropriate money, not to exceed \$25,000.00, determine what measures to take for making emergency repairs to this critical public facility.

Councilmember Robinson moved to add on the above-mentioned items not on the printed agenda. Seconded by Councilmember Boone, motion passed unanimously by voice vote.

Councilmember Robinson moved to approve minutes of the 10 May 2021, regular meeting; minutes of the 10 May 2021, work session; and minutes of the 10 May 2021, agenda meeting. Seconded by Councilmember Boone, motion passed unanimously by voice vote.

Mayor Sullivan addressed the City Council and commented it is busy in Fairhope. She commented on the following projects: Section Street Drainage Project; Public Works Week; Nix Center opening on June 1, 2021; Memorial Day and Beach Booth; and the Budget Calendar.

24 May 2021

The following individual spoke during Public Participation for Agenda Items:

- 1) Gary Gover, 300 Lincoln Street, addressed the City Council regarding Agenda Item No. 7: a resolution that the Fairhope City Council hereby authorizes Mayor Sherry Sullivan to prepare and sign a Letter of Intent for the Fairhope Educational Enrichment Foundation (“FEEF”) to lease a portion of the K-1 Center property and buildings as contained within and specified in the attached Exhibit A- Pages 1 and 2. The lease will be \$1.00 per year (for a term of 25 years). The City Council hereby establishes and declares that the described real property of the City of Fairhope, Alabama, is not needed for public or municipal purposes during the term of this lease. The City of Fairhope will provide insurance for property. FEEF is not allowed to sublet any portion of the property; and will be responsible for maintenance. FEEF will be responsible for improvements to building conditions. The building improvements and educational opportunity constitute a valid public purpose for the City. The specific terms and conditions of which will be detailed in the Lease Agreement to be completed by August 1, 2021. He said this was not very informative and the FEEF usage. He commented there should be more Community engagement.

Councilmember Boone told everyone to have a safe Memorial Day weekend; and reminded everyone that the projects are for the betterment of Fairhope.

Council President Pro Tempore Conyers congratulated the kids for the school year. He also congratulated SALT for the wonderful Bald Eagle Bash this past weekend.

A Public Hearing was held to consider a proposed ordinance for a Franchise Agreement operate Beverage Vending Machines at the locations specified in Bid No. 006-21, Beverage Concession 2021. Councilmember Robinson introduced in writing an ordinance Application from Coca Cola Bottling Company United for a Franchise Agreement to operate Beverage Vending Machines at the locations specified in Bid No. 006-21, Beverage Vending and Concessions 2021 – Three Year; and it is to be in the best interest of the public and the City of Fairhope to grant this franchise. City Clerk Lisa Hanks explained the ordinance which was part of the Bid Award for Concessions.

Council President Pro Tempore Conyers opened the Public Hearing at 6:11 p.m.

- 1) Gary Gover, 300 Lincoln Street, addressed the City Council and said it is not clear where vending machines are located. City Clerk Hanks explained the contract and the vending machine franchise. Mr. Gover said parents were told they must purchase Coke products per agreement.

No one present opposed the proposed ordinance, the Public Hearing closed at 6:17 p.m. Due to lack of a motion for immediate consideration, this ordinance will layover until the June 14, 2021 City Council meeting.

24 May 2021

Councilmember Boone introduced in writing an ordinance directing the Transfer and Declaring certain real property as surplus and not needed for public or municipal purposes, located at the Intersection of County Road 13 and County Road 32 Improvement, Tax ID 05-46-08-33-0-000-009.000: Tract Number 1; containing 0.210 acres, more or less to Baldwin County, Alabama to be used as part of construction of a roundabout at said intersection which will serve a public purpose allowing easier ingress and egress to the City's future sports fields and increase traffic safety at said intersection. Due to lack of a motion for immediate consideration, this ordinance will layover until the June 14, 2021 City Council meeting.

Councilmember Boone introduced in writing, and moved for the adoption of the following resolution, a resolution that the Fairhope City Council hereby authorizes Mayor Sherry Sullivan to prepare and sign a Letter of Intent for the Fairhope Educational Enrichment Foundation ("FEEF") to lease a portion of the K-1 Center property and buildings as contained within and specified in the attached Exhibit A- Pages 1 and 2. The lease will be \$1.00 per year (for a term of 25 years). The City Council hereby establishes and declares that the described real property of the City of Fairhope, Alabama, is not needed for public or municipal purposes during the term of this lease. The City of Fairhope will provide insurance for property. FEEF is not allowed to sublet any portion of the property; and will be responsible for maintenance. FEEF will be responsible for improvements to building conditions. The building improvements and educational opportunity constitute a valid public purpose for the City. The specific terms and conditions of which will be detailed in the Lease Agreement to be completed by August 1, 2021.

The motion was seconded by Councilmember Martin who said he spoke with FEEF. He said this is a great opportunity for the City of Fairhope that includes the Pelican's Nest, Community Engagement, and STEAM participation. Councilmember Martin commented that 25 years for this lease does not bother him. Council President Pro Tempore Conyers stated that this lease is for the four buildings out front and the Pelican's Nest. He said this is the "Education Project Component;" and if it is not being used for its intent, it would revert back to the City. Councilmember Robinson commented this will be great for the City and the program. After further discussion, motion passed unanimously by voice vote.

*

*

*

24 May 2021

RESOLUTION NO. 4092-21

BE IT RESOLVED BY THE GOVERNING BODY OF THE CITY OF FAIRHOPE, ALABAMA, That the Fairhope City Council hereby authorizes Mayor Sherry Sullivan to prepare and sign a Letter of Intent for the Fairhope Educational Enrichment Foundation (“FEEF”) to lease a portion of the K-1 Center property and buildings as contained within and specified in the attached Exhibit A- Pages 1 and 2. The lease will be \$1.00 per year (for a term of 25 years). The City Council hereby establishes and declares that the described real property of the City of Fairhope, Alabama, is not needed for public or municipal purposes during the term of this lease. The City of Fairhope will provide insurance for property. FEEF is not allowed to sublet any portion of the property; and will be responsible for maintenance. FEEF will be responsible for improvements to building conditions. The building improvements and educational opportunity constitute a valid public purpose for the City. The specific terms and conditions of which will be detailed in the Lease Agreement to be completed by August 1, 2021.

Adopted on this 24th day of May, 2021

Jimmy Conyers,
Council President Pro Tempore

Attest:

Lisa A. Hanks, MMC
City Clerk

Councilmember Robinson introduced in writing, and moved for the adoption of the following resolution, a resolution to Authorize the Submission of an FY 2022 Transportation Alternatives Set-Aside Program Grant to the Alabama Department of Transportation to Construct New Sidewalk Facilities along Fairwood Boulevard and Blue Island Avenue. Total project cost is estimated at \$800,000.00; the City will be responsible for providing 20 percent or \$160,000.00. Seconded by Councilmember Boone, motion passed unanimously by voice vote.

24 May 2021

RESOLUTION NO. 4093-21

**AUTHORIZING THE SUBMISSION OF AN FY
2022 TRANSPORTATION ALTERNATIVES SET-ASIDE PROGRAM
GRANT TO THE ALABAMA DEPARTMENT OF TRANSPORTATION
TO CONSTRUCT NEW SIDEWALK FACILITIES ALONG
FAIRWOOD BOULEVARD AND BLUE ISLAND AVENUE**

WHEREAS, the Alabama Department of Transportation (ALDOT) is accepting applications from municipal governments for FY 2022 Transportation Alternatives Set-Aside Program (TAP) Grants; and

WHEREAS, the City of Fairhope has identified the need to provide new sidewalk facilities designated for use by pedestrians along Fairwood Boulevard and Blue Island Avenue in Fairhope; and

WHEREAS, the total project cost is estimated at \$800,000.00, and if funded, the grant will pay 80% or \$640,000.00 and the City of Fairhope will be responsible for providing 20% or \$160,000.00; and

WHEREAS, if funded, the City will see this project through to completion and will be responsible for providing long-term maintenance of the new facilities; and

NOW THEREFORE, BE IT RESOLVED BY THE GOVERNING BODY OF THE CITY OF FAIRHOPE IN REGULAR SESSION ASSEMBLED, that by this Resolution the City of Fairhope authorizes submission of a TAP Grant to ALDOT requesting funds to construct new pedestrian facilities.

BE IT FURTHER RESOLVED, that the City Council authorizes the Mayor to sign all required grant application documents on behalf of the City.

DULY ADOPTED THIS 24TH DAY OF MAY, 2021

Jimmy Conyers,
Council President Pro Tempore

Attest:

Lisa A. Hanks, MMC
City Clerk

24 May 2021

Councilmember Robinson introduced in writing, and moved for the adoption of the following resolution, a resolution that Mayor Sherry Sullivan is hereby authorized to execute Amendment No. 1 to the RSA Agreement for Twin Beech Road dated January 28, 2020, between the City of Fairhope and The Teachers' Retirement System of Alabama and The Employees' Retirement System of Alabama. Seconded by Councilmember Martin, motion passed unanimously by voice vote.

RESOLUTION NO. 4094-21

WHEREAS, the City of Fairhope, Alabama, an Alabama Municipal Corporation, hereinafter referred to as ("City"), and The Teachers' Retirement System of Alabama, an instrumentality of the State of Alabama ("TRS") and The Employees' Retirement System of Alabama, an instrumentality of the State of Alabama ("ERS", together with TRS, "RSA"); entered into an Agreement dated January 28, 2020 and such Agreement remains in effect; and

WHEREAS, the City and RSA desire to modify the Agreement, specifically Paragraph 4, by providing additional time up to March 30, 2023 for the City to perform certain improvements contemplated by the Agreement, and the City and RSA have prepared a First Amendment to Agreement to that effect with the remaining provisions of the Agreement to remain in full force and effect.

BE IT RESOLVED BY THE GOVERNING BODY OF THE CITY OF FAIRHOPE, that Mayor Sherry Sullivan is hereby authorized to execute Amendment No. 1 to the RSA Agreement for Twin Beech Road dated January 28, 2020, between the City of Fairhope and The Teachers' Retirement System of Alabama and The Employees' Retirement System of Alabama.

Adopted this 24th day of May, 2021

Jimmy Conyers,
Council President Pro Tempore

Attest:

Lisa A. Hanks, MMC
City Clerk

24 May 2021

Councilmember Martin introduced in writing, and moved for the adoption of the following resolution, a resolution that City Council hereby authorizes Mayor Sherry Sullivan to enter into a four month rental agreement with Eastern Shore Parents Aquatic Foundation, Inc. (ESPAF) dba S.W.A.T. for certain limited use of the City's municipal pool facility. The limited use shall be for three contiguous swim lanes from 3:30 p.m. to 7:00 p.m. Mondays through Fridays beginning May 25, 2021. The monthly rental fee shall be \$900.00, and each swimmer shall have a Fairhope municipal pool membership. ESPAF shall name the City as an additional insured on its policy and shall execute a hold harmless/indemnity agreement with the City. Any and all recreation department activities shall take priority over any ESPAF use of the facility. The recreation department shall endeavor to provide a 48 hour notice to ESPAF of any potential use conflict. Seconded by Councilmember Robinson, motion passed unanimously by voice vote.

RESOLUTION NO. 4095-21

BE IT RESOLVED BY THE GOVERNING BODY OF THE CITY OF FAIRHOPE, ALABAMA, That City Council hereby authorizes Mayor Sherry Sullivan to enter into a four month rental agreement with Eastern Shore Parents Aquatic Foundation, Inc. (ESPAF) dba S.W.A.T. for certain limited use of the City's municipal pool facility. The limited use shall be for three contiguous swim lanes from 3:30 p.m. to 7:00 p.m. Mondays through Fridays beginning May 25, 2021. The monthly rental fee shall be \$900.00, and each swimmer shall have a Fairhope municipal pool membership. ESPAF shall name the City as an additional insured on its policy and shall execute a hold harmless/indemnity agreement with the City. Any and all recreation department activities shall take priority over any ESPAF use of the facility. The recreation department shall endeavor to provide a 48 hour notice to ESPAF of any potential use conflict.

DULY ADOPTED THIS 24TH DAY OF MAY, 2021

Jimmy Conyers,
Council President Pro Tempore

Attest:

Lisa A. Hanks, MMC
City Clerk

24 May 2021

Councilmember Robinson introduced in writing, and moved for the adoption of the following resolution, a resolution that the City Council approves the selection of S.E. Civil, LLC to perform Professional Engineering Services for Water Main Replacement at SR 181 along ROW to CR 34 for the Water Department; and hereby authorizes Mayor Sherry Sullivan to negotiate a fee schedule and establish a not-to-exceed limit with this firm. Seconded by Councilmember Boone, motion passed unanimously by voice vote.

RESOLUTION NO. 4096-21

BE IT RESOLVED BY THE GOVERNING BODY OF THE CITY OF FAIRHOPE, ALABAMA, That the City Council approves the selection of S.E. Civil, LLC to perform Professional Engineering Services for Water Main Replacement at SR 181 along ROW to CR 34 for the Water Department; and hereby authorizes Mayor Sherry Sullivan to negotiate a fee schedule and establish a not-to-exceed limit with this firm.

DULY ADOPTED THIS 24TH DAY OF MAY, 2021

Jimmy Conyers,
Council President Pro Tempore

Attest:

Lisa A. Hanks, MMC
City Clerk

Councilmember Robinson introduced in writing, and moved for the adoption of the following resolution, a resolution that the City Council approves the selection of Lieb Engineering Company to perform Professional Engineering Services for Design and Construction Administration for additional Ballfields and Parking for the Recreation Department; and hereby authorizes Mayor Sherry Sullivan to negotiate a fee schedule and establish a not-to-exceed limit with this firm. Seconded by Councilmember Martin, motion passed unanimously by voice vote.

24 May 2021

RESOLUTION NO. 4097-21

BE IT RESOLVED BY THE GOVERNING BODY OF THE CITY OF FAIRHOPE, ALABAMA, That the City Council approves the selection of Lieb Engineering Company to perform Professional Engineering Services for Design and Construction Administration for additional Ballfields and Parking for the Recreation Department; and hereby authorizes Mayor Sherry Sullivan to negotiate a fee schedule and establish a not-to-exceed limit with this firm.

DULY ADOPTED THIS 24TH DAY OF MAY, 2021

Jimmy Conyers,
Council President Pro Tempore

Attest:

Lisa A. Hanks, MMC
City Clerk

Councilmember Martin introduced in writing, and moved for the adoption of the following resolution, a resolution that the City Council approves the selection of EnCompass360 to perform Professional Services to conduct FEMA-HMGP Grant Application, Program Management, and Grant Administration for a FEMA Rate First Responder Safe Room; and hereby authorizes Mayor Sherry Sullivan to execute a contract with a total cost of \$60,000.00 which is an unbudgeted item. Seconded by Councilmember Robinson, motion passed unanimously by voice vote.

RESOLUTION NO. 4098-21

BE IT RESOLVED BY THE GOVERNING BODY OF THE CITY OF FAIRHOPE, ALABAMA, that the City Council approves the selection of EnCompass360 to perform Professional Services to conduct FEMA-HMGP Grant Application, Program Management, and Grant Administration for a FEMA Rate First Responder Safe Room; and hereby authorizes Mayor Sherry Sullivan to execute a contract with a total cost of \$60,000.00 which is an unbudgeted item. The first \$30,000.00 due upon execution of agreement; and \$30,000.00 due upon submission to FEMA for project review.

DULY ADOPTED THIS 24TH DAY OF MAY, 2021

Jimmy Conyers,
Council President Pro Tempore

Attest:

Lisa A. Hanks, MMC
City Clerk

24 May 2021

Councilmember Robinson introduced in writing, and moved for the adoption of the following resolution, a resolution that the City hereby awards the contract for the Fairhope Area Community Based Comprehensive Land Use Plan RFP PS001-21 for ADCNR Grant #S1P17-FACP (RESTORE Act) to Neel-Schaffer with a fee not-to-exceed \$526,500.000 of grant funds; and authorizes the Mayor to execute the contract with this firm. Seconded by Councilmember Boone, motion passed unanimously by voice vote.

RESOLUTION NO. 4099-21

**AWARDING THE RFP PS001-21 FAIRHOPE AREA COMMUNITY
BASED COMPREHENSIVE LAND USE PLAN CONTRACT FOR
THE ALABAMA DEPARTMENT OF CONSERVATION AND
NATURAL RESOURCES GRANT #S1P17-FACP (RESTORE ACT)**

WHEREAS, the City of Fairhope was awarded a RESTORE Act Direct Component Subrecipient Grant (#S1P17-FACP) from the Alabama Department of Conservation and Natural Resources (ACDNR) on April 16, 2020; and

WHEREAS, the City did solicit Requests for Proposals (RFP PS001-21) in accordance with applicable federal, state, and local laws, codes, regulations, ordinances, etc. including but not limited to all executive orders (EO), Office of Management and Budget (OMB) requirements, and U.S. Treasury Regulations; and

WHEREAS, the City did receive and evaluate proposals from qualified firms for said services, and the City's Evaluation Committee determined Neel-Schaffer to be the most qualified firm and recommends that this firm be selected for said services; and

WHEREAS, the amount obligated for the Fairhope Area Community Based Comprehensive Land Use Plan of the Subrecipient Grant by the U.S. Department of Treasury is Five Hundred Twenty-Six Thousand, Five-Hundred Dollars (\$526,500.000); and

WHEREAS, One-hundred percent (100%) of the Fairhope Area Community Based Comprehensive Land Use Plan fees will be paid for with grant funds made available through the Subrecipient Grant Agreement #S1P7-FACP with ADCNR.

NOW, THEREFORE IT BE RESOLVED BY THE City of Fairhope, IN REGULAR SESSION ASSEMBLED, that by this Resolution the City of Fairhope awards the contract for the Fairhope Area Community Based Comprehensive Land Use Plan (RFP PS001-21) for ADCNR Grant #S1P7-FACP to Neel-Schaffer, subject to review and approval by ADCNR and City Attorney prior to execution; and

24 May 2021

BE IT FURTHER RESOLVED BY THE City of Fairhope, that the City hereby awards the contract for the Fairhope Area Community Based Comprehensive Land Use Plan RFP PS001-21 for ADCNR Grant #S1P17-FACP (RESTORE Act) to Neel-Schaffer with a fee not-to-exceed \$526,500.000 of grant funds; and authorizes the Mayor to execute the contract with this firm.

DULY ADOPTED THIS 24TH DAY OF MAY, 2021.

Jimmy Conyers,
Council President Pro Tempore

Attest:

Lisa A. Hanks, MMC
City Clerk

Councilmember Boone introduced in writing, and moved for the adoption of the following resolution, a resolution that Mayor Sherry Sullivan is hereby authorized to execute Change Order No. 1 to Bid Number 010-20, Church Street Utility and Drainage Improvements for Replacement of 482 Linear Feet of Existing Gas Main and 9 Gas Services with an increased cost in an amount of \$32,746.00; and award the Change Order to Asphalt Services, Inc. Seconded by Councilmember Martin, motion passed unanimously by voice vote.

RESOLUTION NO. 4100-21

BE IT RESOLVED BY THE GOVERNING BODY OF THE CITY OF FAIRHOPE, ALABAMA, That Mayor Sherry Sullivan is hereby authorized to execute Change Order No. 1 to Bid Number 010-20, Church Street Utility and Drainage Improvements for Replacement of 482 Linear Feet of Existing Gas Main and 9 Gas Services with an increased cost in an amount of \$32,746.00; and award the Change Order to Asphalt Services, Inc.

Adopted on this 24th day of May, 2021

Jimmy Conyers,
Council President Pro Tempore

Attest:

Lisa A. Hanks, MMC
City Clerk

24 May 2021

Councilmember Robinson introduced in writing, and moved for the adoption of the following resolution, a resolution to Award Bid for Installation of SIGNA UV at Treatment Plant for the Sewer Department (Bid No. 017-21) to Rob't. J. Baggett, Inc. with a total cost of \$182,221.00. Seconded by Councilmember Boone, motion passed unanimously by voice vote.

RESOLUTION NO. 4101-21

BE IT RESOLVED BY THE GOVERNING BODY OF THE CITY OF FAIRHOPE, ALABAMA, as follows:

[1] That the City of Fairhope did request, receive, and open bids for Installation of SIGNA UV at Treatment Plant for the Sewer Department. (Bid Number 019-21).

[2] At the appointed time and place, the following bids were opened and tabulated as follows:

Please see attached Bid Tabulations for
Installation of SIGNA UV at Treatment Plant
for the Sewer Department

[3] After evaluating the bid proposals with the required bid specifications, Rob't. J. Baggett, Inc. with a total bid proposal of \$182,221.00, is now awarded the bid for Installation of SIGNA UV at Treatment Plant for the Sewer Department.

Adopted on this 24th day of May, 2021

Jimmy Conyers,
Council President Pro Tempore

Attest:

Lisa A. Hanks, MMC
City Clerk

*

*

24 May 2021

THE CITY OF FAIRHOPE, AL								
TABULATION OF BIDS RECEIVED ON MAY 4, 2021								
INSTALLATION OF SIGNA UV AT TREATMENT FACILITY								
CONTRACT NO. WA003-21/BID NO. 017-21								
(VOLKERT PROJECT NO. 0648010)								
Item No.	Item Description	Unit	Estimated Quantity	1 Rob't. J. Baggett, Inc.		2 J & P Construction Co., Inc.		
				Unit Price	Total Amount	Unit Price	Total Amount	
GC-1	Removal & Replacement of Existing Trojan UV 4000 Disinfection System with Owner Furnished Trojan UV Signa Disinfection System	LS	1	\$142,221.00	\$142,221.00	\$258,000.00	\$258,000.00	
AL-1	General Allowance	LS	1	\$15,000.00	\$15,000.00	\$15,000.00	\$15,000.00	
AL-2	SCADA Allowance	LS	1	\$25,000.00	\$25,000.00	\$25,000.00	\$25,000.00	
TOTAL BID AMOUNT				\$182,221.00		\$298,000.00		

I, Ray Miller, P.E., Vice President, Gulf Region Utilities Operations Manager, Volkert, Inc., Consulting Engineers, do hereby certify that this tabulation of bids received on May 4, 2021, for the herein referenced project, is a true and correct copy of the bids submitted by the within named persons.

 Ray Miller, P.E., Vice President
 Gulf Region Utilities Operations Manager
 Volkert, Inc.

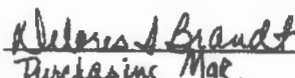
 Purchasing Mgr.

Councilmember Robinson introduced in writing, and moved for the adoption of the following resolution, a resolution to Award Bid for Ready-Mix Concrete for the City (Bid No. 025-21) to Ready Mix USA, LLC with a total bid proposal for the unit amounts shown in the attached bid tabulation. Seconded by Councilmember Boone, motion passed unanimously by voice vote.

24 May 2021

RESOLUTION NO. 4102-21

BE IT RESOLVED BY THE GOVERNING BODY OF THE CITY OF FAIRHOPE, ALABAMA, as follows:

[1] That the City of Fairhope did request, receive, and open bids for Ready-mix Concrete for the City (Bid No. 025-21) at 555 South Section Street in the City of Fairhope offices, Fairhope, Alabama.

[2] At the appointed time and place, the following bids were opened and tabulated as follows:

Please see attached Bid Tabulation for
Ready-mix Concrete for the City

[3] After evaluating the bid proposals with the required bid specifications, Ready Mix USA, LLC, with a bid proposal for the unit amounts shown in the attached bid tabulation, is now awarded the annual bid Ready-mix Concrete for the City.

Adopted on this 24th day of May, 2021

Jimmy Conyers,
Council President Pro Tempore

Attest:

Lisa A. Hanks, MMC
City Clerk

*

*

*

24 May 2021

CITY OF FAIRHOPE TAB AND RECOMMENDATION
 BID NO: 025-21
 BID NAME: Ready-Mix Concrete 2021
 BID OPENED: Tuesday, May18, 2021 1:00 p.m.

	Bid Response Executed/ Signed/ Notarized	Vendor Compliance Yes or No	Manufacturer	ARO in Hours	3000PSI with peagravel per Cubic Yard/ Delivered to Job Site	4000PSI with peagravel per Cubic Yard/ Delivered to Job Site	3000PSI with regular gravel per Cubic Yard/ Delivered to Job Site	4000PSI with regular gravel per Cubic Yard/ Delivered to Job Site	Accelerant per Fluid Ounce
Vendor: READY MIX USA	yes	yes			\$119.00	\$123.00	\$114.00	\$118.00	\$ 6.00(1%)
Minimum Quantity					5 yds	5 yds	5 yds	5 yds	\$10.00 (2%)
Upcharge for Less Than Minimum Quantity					\$150.00	\$150.00	\$150.00	\$150.00	
Multiple Stop Charge					\$75.00	\$75.00	\$75.00	\$75.00	
Vendor Name									
Minimum Quantity									
Upcharge for Less Than Minimum Quantity									
Multiple Stop Charge									

RECOMMENDATION: AWARD bid to Ready Mix USA, LLC
 Digitally signed by
 Richard D. Johnson, PE
 Date: 2021.05.18 15:23:05 -05'00' 05/18/2021
 Signature Date
 Richard D Johnson, Public Works Director
 Delores A Brandt 5/18/21
 Signature Date
 Delores A Brandt, Purchasing Manager
 To the best of my knowledge this is an accurate Bid Tabulation

Councilmember Boone introduced in writing, and moved for the adoption of the following resolution, a resolution that the City of Fairhope has voted to purchase Over Pressure Protection (OPP) and Emerson's Zedi Cloud SCADA Solution for Gas Utilities Monitoring 11 sites including the Gate Station Sites for the Gas Department from John H. Carter Company, Inc., or its subsidiary, ControlWorx, LLC, as Sole Source Distributor in the Southern third of Alabama; and authorizes procurement without formal bid based on the option allowed by the Code of Alabama 1975, Section 41-16-51(13). The cost will be \$27,283.45 (\$21,823.45 equipment plus \$455.00 per month for the 11 sites). Seconded by Councilmember Martin, motion passed unanimously by voice vote.

24 May 2021

RESOLUTION NO. 4103-21

BE IT RESOLVED BY THE GOVERNING BODY OF THE CITY OF FAIRHOPE, ALABAMA, as follows:

[1] That the City of Fairhope has voted to purchase Over Pressure Protection (OPP) and Emerson's Zedi Cloud SCADA Solution for Gas Utilities Monitoring 11 sites including the Gate Station Sites for the Gas Department from John H. Carter Company, Inc., or its subsidiary, ControlWorx, LLC, as Sole Source Distributor in the Southern third of Alabama; and authorizes procurement without formal bid based on the option allowed by the Code of Alabama 1975, Section 41-16-51(13). The cost will be \$27,283.45 (\$21,823.45 equipment plus \$455.00 per month for the 11 sites).

Adopted on this 24th day of May, 2021

Jimmy Conyers,
Council President Pro Tempore

Attest:

Lisa A. Hanks, MMC
City Clerk

Councilmember Boone introduced in writing, and moved for the adoption of the following resolution, a resolution that the City of Fairhope has voted to purchase Forty (40) LED Lights to upgrade Lighting on U. S. 98 (Greeno Road) from State Highway 104 to Parker Road for the Electric Department from GRESCO; and authorizes procurement without formal bid based on the option allowed by the Code of Alabama 1975, Section 41-16-51(b)(7). The cost will be \$49,000.00. Seconded by Councilmember Robinson, motion passed unanimously by voice vote.

*

*

24 May 2021

RESOLUTION NO. 4104-21

BE IT RESOLVED BY THE GOVERNING BODY OF THE CITY OF FAIRHOPE, ALABAMA, as follows:

[1] That the City of Fairhope has voted to purchase Forty (40) LED Lights to upgrade Lighting on U. S. 98 (Greeno Road) from State Highway 104 to Parker Road for the Electric Department from GRESCO; and authorizes procurement without formal bid based on the option allowed by the Code of Alabama 1975, Section 41-16-51(b)(7). The cost will be \$49,000.00.

Adopted on this 24th day of May, 2021

Jimmy Conyers,
Council President Pro Tempore

Attest:

Lisa A. Hanks, MMC
City Clerk

Councilmember Martin introduced in writing, and moved for the adoption of the following resolution, a resolution that the City of Fairhope has voted to procure one (1) Trane Odyssey Split System Air Conditioning Unit for the James P. Nix Center; and the equipment is available for direct procurement through the CO-OP Contract through US Communities #USC 15-JLP-023 and other vendors for installation. The total unbudgeted not-to-exceed cost is \$12,500.00. Seconded by Councilmember Boone, motion passed unanimously by voice vote.

RESOLUTION NO. 4105-21

BE IT RESOLVED BY THE GOVERNING BODY OF THE CITY OF FAIRHOPE, ALABAMA, as follows:

[1] That the City of Fairhope has voted to procure one (1) Trane Odyssey Split System Air Conditioning Unit for the James P. Nix Center; and the equipment is available for direct procurement through the CO-OP Contract through US Communities #USC 15-JLP-023 and other vendors for installation. The total unbudgeted not-to-exceed cost is \$12,500.00.

Adopted on this 24th day of May, 2021

Jimmy Conyers,
Council President Pro Tempore

Attest:

Lisa A. Hanks, MMC
City Clerk

24 May 2021

Councilmember Robinson moved to appoint Morgan Slay to the Parking Authority for a three-year term which will expire May 2024. Seconded by Councilmember Martin, motion passed unanimously by voice vote.

Councilmember Boone moved to appoint Knox McMurphy and May-Moss Parker to the Tree Committee for a three-year term which will expire May 2024. Seconded by Councilmember Martin, motion passed unanimously by voice vote.

Councilmember Robinson introduced in writing, and moved for the adoption of the following resolution, a resolution that the City Council of the City of Fairhope hereby officially declares an emergency as an electrical panel needing to be replaced and moved due to the panel overheating and jeopardizing the power to part of the building and the testing lab at the City of Fairhope's Wastewater Treatment Plant Building; authorizes Mayor Sherry Sullivan to hire a certified electrician to assess the damage; and to appropriate money, not to exceed \$25,000.00, determine what measures to take for making emergency repairs to this critical public facility. Seconded by Councilmember Martin, motion passed unanimously by voice vote.

RESOLUTION NO. 4106-21

WHEREAS, the City of Fairhope's Wastewater Treatment Plant Building needs immediate attention due to an electrical panel needing to be replaced and moved due to the panel overheating and jeopardizing the power to part of the building and the testing lab; and

WHEREAS, there is a need for the City to hire a certified electrician to assess the panel damage and determine what measures to take for making emergency repairs to this critical public facility and to provide adequately for the health, safety, and convenience of the employees without delay; and

WHEREAS, the City Council, due to the emergency circumstances requiring immediate action to avoid further damage to property, the City of Fairhope's Wastewater Treatment Plant Building, is desirous of declaring an "Emergency" pursuant to Code of Alabama 1975, Section 39-2-2(e); so that immediate repairs may be contracted to avoid additional damages to the building via soliciting informal bids for repairs.

NOW, THEREFORE, BE IT RESOLVED BY THE GOVERNING BODY OF THE CITY OF FAIRHOPE, ALABAMA, WHILE IN REGULAR SESSION ON May 24, 2021, as follows: the City Council of the City of Fairhope hereby officially declares an emergency as an electrical panel needing to be replaced and moved due to the panel overheating and jeopardizing the power to part of the building and the testing lab at the City of Fairhope's Wastewater Treatment Plant Building; authorizes Mayor Sherry Sullivan to hire a certified electrician to assess the damage; and to appropriate money, not to exceed \$25,000.00, determine what measures to take for making emergency repairs to this critical public facility.

ADOPTED AND APPROVED THIS 24TH DAY OF MAY, 2021

Jimmy Conyers,
Council President Pro Tempore

Attest

Lisa A. Hanks, MMC
City Clerk

24 May 2021

At the request of the City Attorney, Marcus E. McDowell, the City Council will rise from the meeting to go into Executive Session based on Section 36-25A-7(a)(3) to discuss pending litigation and possible settlement options regarding said pending litigation. The approximate time to be in Executive Session is 40 minutes. Councilmember Robinson moved to go into Executive Session. Seconded by Councilmember Martin, motion passed unanimously by voice vote.

Exited the dais at 6:53 p.m. Returned at 7:52 p.m.

Councilmember Robinson moved to adjourn the meeting. Seconded by Councilmember Martin, motion passed unanimously by voice vote.

There being no further business to come before the City Council, the meeting was duly adjourned at 7:52 p.m.

Jimmy Conyers,
Council President Pro Tempore

Lisa A. Hanks, MMC
City Clerk

STATE OF ALABAMA)(
:
COUNTY OF BALDWIN)(
)

The City Council met in a Work Session
at 4:30 p.m., Fairhope Municipal Complex Council Chamber,
161 North Section Street, Fairhope, Alabama 36532,
on Monday, 24 May 2021.

Present were Council President Pro Tempore Jimmy Conyers, Councilmembers: Corey Martin, Jay Robinson, and Kevin Boone (Arrived at 4:32 p.m.), Mayor Sherry Sullivan, City Attorney Marcus E. McDowell, and City Clerk Lisa A. Hanks. Council President Jack Burrell was absent

Council President Pro Tempore Jimmy Conyers called the meeting to order at 4:30 p.m.

The following topics were discussed:

- The first item on the Agenda was the Presentation from Baldwin County Economic Development Alliance to present their proposed application for the K-1 Center by Lee Lawson. He said that this was an America Rescue Plan grant; and this will be an updated grant application with an 80/20 percent match. Mr. Lawson stated the grant is less than the last one; and will be for \$3.5 million and the City would be the lead applicant. He said that hopefully it would be out in a month, but is waiting on the "Notice of Funding." The consensus of the City Council was to move forward and for the City Clerk to prepare a resolution for the June 14, 2021 City Council meeting.
- Rick Hinrichs addressed the City Council and presented the Working Waterfront ADA Compliancy Report. (See attached Report) He mentioned Federal laws requiring ADA compliancy for Program Services and Activities; and said this will fall under Activities. Mr. Hinrichs said the ramp is needed; and also, a bluff edge access for wheelchairs. He said these are Government grant funds from the Restore Act which requires ADA compliancy from Section 504 for non-discrimination. The City Council questioned Fairhope Avenue; and other options. Mr. Hinrich stated compliance began in 1992 with access to be 200 feet from site; and the ramp in plan is 800 feet from site, but is the best access for wheelchairs and handicap individuals. Mayor Sullivan asked about a cable car of some sort for Council President Burrell. Mr. Hinrichs replied it would have to be large enough for a wheelchair and another person; and you must be able to lock down wheelchair so it will not move.
- The Discussion for the Triangle Property and Conservation Easement was next on the Agenda Councilmember Martin commented there are two options: one is to use as Parkland or have a Conservation Easement.

Mayor Sullivan said we could get a deed from Fairhope Single Tax Corporation. She said that if we are awarded a grant from ADECA, they would require any improvements to be approved by them. Council President Pro Tempore Conyers said we could consider deeding the property to Fairhope Single Tax Corporation. Then Fairhope Single Tax Corporation would deed back to the City with Park restrictions.

Monday, May 24, 2021

Page -3-

- Building Official Erik Cortinas addressed the City Council and mentioned the two Publix grocery stores being built: one at the intersection of Greeno Road and Old Battles Road (County Road 34); and one at State Highway 181 and State Highway 104. He mentioned office building near Volanta.
- City Treasurer Kim Creech addressed the City Council and said FEMA approved \$7.0 million; and was noticed on State's website. She said the Electric Department is the next large portion; and the Buildings will be next.

There being no further business to come before the City Council, the meeting was duly adjourned at 5:35 p.m.

Jack Burrell, Council President

Lisa A. Hanks, MMC
City Clerk

Monday, May 24, 2021

Page -3-

- Building Official Erik Cortinas addressed the City Council and mentioned the two Publix grocery stores being built: one at the intersection of Greeno Road and Old Battles Road (County Road 34); and one at State Highway 181 and State Highway 104. He mentioned office building near Volanta.
- City Treasurer Kim Creech addressed the City Council and said FEMA approved \$7.0 million; and was noticed on State's website. She said the Electric Department is the next large portion; and the Buildings will be next.

There being no further business to come before the City Council, the meeting was duly adjourned at 5:35 p.m.

Jimmy Conyers,
Council President Pro Tempore

Lisa A. Hanks, MMC
City Clerk

STATE OF ALABAMA)
 :
COUNTY OF BALDWIN)

The City Council met in an Agenda Meeting at 5:30 p.m.,
Fairhope Municipal Complex Council Chamber,
161 North Section Street, Fairhope, Alabama 36532,
on Monday, 24 May 2021.

Present were Council President Pro Tempore Jimmy Conyers, Councilmembers: Corey Martin, Jay Robinson, and Kevin Boone, Mayor Sherry Sullivan, City Attorney Marcus E. McDowell, and City Clerk Lisa A. Hanks. Council President Jack Burrell was absent.

Council President Pro Tempore Conyers called the meeting to order at 5:35 p.m. The City Council reviewed and discussed the agenda for their meeting to be held today at 6:00 p.m. Community Affairs Director Paige Crawford briefly explained Agenda Item Number 20 regarding the need for an air conditioner in the front area of the Nix Center. She introduced Kim Ryland who is over the Nix Center. Ms. Ryland announced that the Nix Center will open on June 1, 2021.

Council President Pro Tempore stated there was a need to add two agenda items on the City Council agenda: Tree Committee nominees and a Resolution regarding an electrical panel issue at the Wastewater Treatment Plant.

There being no further business to come before the City Council, the meeting was duly adjourned at 5:45 p.m.

Jimmy Conyers,
Council President Pro Tempore

Lisa A. Hanks, MMC
City Clerk

ORDINANCE NO. ____

**AN ORDINANCE AMENDING ORDINANCE NO. 1253
KNOWN AS THE ZONING ORDINANCE**

BE IT ORDAINED BY THE CITY COUNCIL OF THE CITY OF FAIRHOPE, ALABAMA as follows:

The ordinance known as the Zoning Ordinance (No. 1253), adopted 27 June 2005, together with the Zoning Map of the City of Fairhope, be and the same hereby is changed and altered in respect to that certain property described below:

After the appropriate public notice and hearing of the Planning Commission of the City of Fairhope, Alabama has forwarded a **favorable** recommendation,

The property of Roberta U. Harris; Stephen J. Urbanek, II; and Margaret U. Dunnam generally located southeast corner of the intersection of County Road 48 and Blueberry Lane, Fairhope, Alabama.

Overland PUD

PPIN # 43640

Legal Description: (Case number ZC 21.01)

COMMENCE AT A RAILROAD SPIKE AT THE NORTHWEST CORNER OF THE NORTHWEST QUARTER OF THE SOUTHEAST QUARTER OF SECTION 14, TOWNSHIP 6 SOUTH RANGE 2 EAST, BALDWIN COUNTY, ALABAMA, AND RUN THENCE SOUTH 00 DEGREES 20 MINUTES 38 SECONDS WEST, A DISTANCE OF 40.00 FEET TO A CAPPED REBAR (FAIRHOPE) ON THE SOUTH RIGHT-OF-WAY OF FAIRHOPE AVENUE, SAID POINT ALSO BEING THE NORTHEAST CORNER OF RIVER MILL UNIT 1, AS SHOWN BY MAP OR PLAT THEREOF RECORDED AT SLIDE 1541-B, BALDWIN COUNTY PROBATE RECORDS, FOR THE POINT OF BEGINNING; CONTINUE THENCE SOUTH 00 DEGREES 20 MINUTES 38 SECONDS WEST, ALONG THE WEST LINE OF SAID RIVER MIL UNIT 1, A DISTANCE OF 532.55 FEET TO A CAPPED REBAR (MOORE); THENCE RUN SOUTH 00 DEGREES 22 MINUTES 09 SECONDS WEST, CONTINUING ALONG SAID WEST LINE OF RIVER MILL, A DISTANCE OF 751.65 FEET TO A CAPPED REBAR (FAIRHOPE); THENCE RUN SOUTH 89 DEGREES 43 MINUTES 52 SECONDS EAST, A DISTANCE OF 1041.41 FEET TO A CAPPED REBAR (FAIRHOPE); THENCE RUN NORTH 00 DEGREES 19 MINUTES 01 SECONDS EAST, A DISTANCE OF 1285.40 FEET TO A CAPPED REBAR (FAIRHOPE) ON THE AFOREMENTIONED SOUTH RIGHT-OF-WAY OF FAIRHOPE AVENUE; THENCE RUN NORTH 89 DEGREES 47 MINUTES 51 SECONDS WEST, ALONG SAID SOUTH RIGHT-OF-WAY, A DISTANCE OF 1040.47 FEET TO THE POINT OF BEGINNING. TRACT CONTAINS 30.70 ACRES, MORE OR LESS.

1. **That**, attached as "Exhibit A" is an approved site plan. The property must develop in substantial conformance with the approved site plan and supporting documents. Any substantial deviation from the attached site plan, as determined by the Director of Planning, will require re-approval by the Planning Commission and the City Council of the City of Fairhope, Alabama, as a PUD amendment.
2. **That**, attached as "Exhibit B" is an approved Master Development Plan (MDP). The property must develop in substantial conformance with the approved MDP. Any substantial deviation from the attached MDP, as determined by the Director of Planning, will require re-approval by the Planning Commission and the City Council of the City of Fairhope, Alabama, as a PUD amendment.

Ordinance No. _____

Page -2-

3. **That**, the following development regulations shall govern:

Overall Development:

Lots: There shall be 62 lots total.

Use: In general, the project is restricted for residential use. The uses are specifically described within the Site Plan and Master Development Plan that include:

- 61 Single Family Residential Lots
- 1 Multifamily Lot consisting of a maximum of 4 quadplexes

Dimension Standards: Dimensional standards shall follow the layout on the approved site plan.

Density: 2.51 UPA.

Sidewalks and Street Trees: All sidewalks and street trees shall be installed prior to submission of Final Plat Approval, including sidewalks along Fairhope Avenue.

Drainage and Detention: Drainage and detention shall meet the Stormwater Standards in the Fairhope Subdivision Regulations.

Buffers: Buffers shall meet the applicable requirements of all City of Fairhope Regulations.

Single Family Residential Development:

Lots: There shall be 61 single family residential lots.

Use: Lots shall be single family residential.

Setbacks: Front – 25', Rear – 25', Side – 5', and Street Side – 20'.

Principle Structure Lot Coverage: Shall not exceed 45% of the total lot.

Building Height: Maximum building height shall not exceed 30'.

Lot Size: Minimum lot size shall be 6,500 square feet.

Multi-Family Residential Development:

Lots: There shall be 1 multi-family residential lot.

Use: Lot shall be multi-family residential with a maximum of 16 townhome units located in 4 quadplexes.

Setbacks: As shown on site plan.

Building Height: Maximum building height shall not exceed 35'.

The property is hereby initially zoned Planned Unit Development (PUD) concurrent with annexation into the City of Fairhope. This property shall hereafter be lawful to construct on such property any structures permitted by Ordinance No. 1253 and to use said premises for any use permitted or building sought to be erected on said property shall be in compliance with the building laws of the City of Fairhope and that any structure shall be approved by the Building Official of the City of Fairhope and that any structure be erected only in compliance with such laws, including the requirements of Ordinance No. 1253.

Ordinance No. _____

Page -3-

Severability Clause - if any part, section or subdivision of this ordinance shall be held unconstitutional or invalid for any reason, such holding shall not be construed to invalidate or impair the remainder of this ordinance, which shall continue in full force and effect notwithstanding such holding.

Effective Date – This ordinance shall take effect immediately upon its due adoption and publication as required by law.

Adopted and approved this 14th day of June, 2021.

By: _____
Jack Burrell, Council President

Attest:

By: _____
Lisa A. Hanks, MMC
City Clerk

Adopted and approved this 14th day of June, 2021.

By: _____
Sherry Sullivan, Mayor

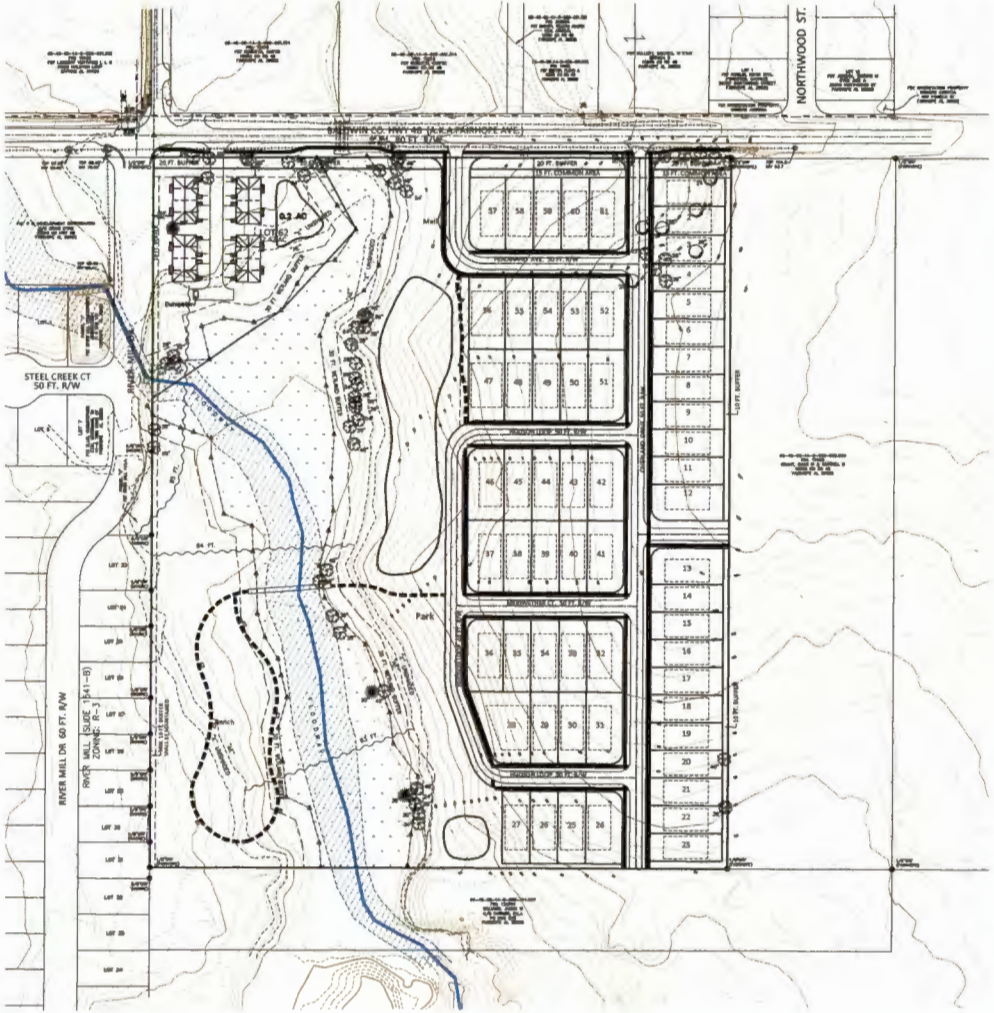

OWNER
 ROBERTA U. HARRIS, STEPHEN
 JOHN URBANEK II, AND
 MARGARET URBANEK DUNNAM
 10824 U.S. HWY 98
 FAIRHOPE AL 36532

DEVELOPER
 88V PAYDIRT, LLC
 29891 WOODROW LANE, SUITE 300
 SPANISH FORT AL 36527

PARCEL NO: 05-46-06-14-0-000-002.000

SITE DATA
 CURRENT ZONING: NONE
 PROPOSED ZONING: P.U.D.
 MAX BLDG HEIGHT (SF): 30 FT
 MAX BLDG HEIGHT (TH): 35 FT
 MAX COVERAGE:
 (PRINCIPAL STRUCT) 45%
 MINIMUM HOUSE: 1,600 SF
 LIN. FT. STREETS: 3,468 LF
 SF LOTS: 61
 M.F. UNITS: 16
 TOTAL UNITS: 77
 DENSITY: 2.51 / AC
 MINIMUM LOT: 6,500 SF
 SMALLEST LOT: 6,500 SF
 LARGEST SF LOT: 11,338 SF
 AVG LOT: 7,087 SF
 LARGEST LOT: 2.42 AC (T.H. PARCEL)
 COMMON AREAS: 14.89 AC (49%)
 TOTAL AREA: 30.70 AC

S.F. REQUIRED SETBACKS:
 FRONT: 25 FEET
 REAR: 25 FEET
 SIDE: 5 FEET
 SIDE STREET: 20 FEET

WATER SERVICE: CITY OF FAIRHOPE
 SEWER SERVICE: CITY OF FAIRHOPE
 ELECTRIC SERVICE: BALDWIN EMC
 TELEPHONE SERVICE: AT&T

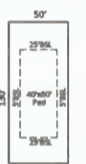

TYPICAL LOT

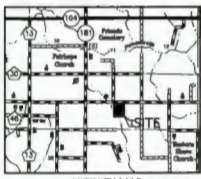

VICINITY MAP
 1" = 1 MILE

LAND USE PERCENTAGES

Single Fam. (Residential)	13.55 Ac	44%
Townhome (Residential)	0.85 Ac	3%
Wetlands	5.16 Ac	17%
Ponds	1.5 Ac	5%
Upland Open Space	8.57 Ac	28%
Buffers	1.07 Ac	3%
TOTAL	30.7 Acres	100%

GREEN SPACE DENSITY CALCULATION

30.70 TOTAL GROSS ACRES
 -11.19 R.O.W., DETENTION & WETLANDS
 19.51 ACRES

77/19.51 = 3.94 UNITS PER ACRE (G.S. DENSITY)
 15% REQUIRED (4.61 AC.)

QUALIFYING GREEN SPACE CALCULATION

8.57 UPLAND AREAS
 0.45 30% OF PONDS
 9.02 TOTAL ACRES (29.4% OF TOTAL SITE)

SURVEYOR'S CERTIFICATE
 I HEREBY STATE THAT ALL PARTS OF THIS SURVEY AND DRAWING HAVE BEEN COMPLETED IN ACCORDANCE WITH THE CURRENT REQUIREMENTS OF THE STANDARDS OF PRACTICE FOR SURVEYING IN THE STATE OF ALABAMA TO THE BEST OF MY KNOWLEDGE, INFORMATION, AND BELIEF.

COMMENCE AT A RAILROAD SPIKE AT THE NORTHWEST CORNER OF THE NORTHWEST QUARTER OF THE SOUTHEAST QUARTER OF SECTION 14, TOWNSHIP 8 SOUTH RANGE 2 EAST, BALDWIN COUNTY, ALABAMA, AND RUN THENCE SOUTH 00 DEGREES 20 MINUTES 30 SECONDS WEST, A DISTANCE OF 40.00 FEET TO A CAPPED REBAR (FAIRHOPE) ON THE SOUTH RIGHT-OF-WAY OF FAIRHOPE AVENUE, SAID POINT ALSO BEING THE NORTHWEST CORNER OF RIVER MILL UNIT 1, AS SHOWN BY MAP OR PLAT THEREOF RECORDED AT SLIDE 1541-B, BALDWIN COUNTY PROBATE RECORDS, FOR THE POINT OF BEGINNING, CONTINUE THENCE SOUTH 00 DEGREES 20 MINUTES 30 SECONDS WEST ALONG THE WEST LINE OF SAID RIVER MILL UNIT 1, A DISTANCE OF 352.55 FEET TO A CAPPED REBAR (INDICED), THENCE RUN SOUTH 00 DEGREES 22 MINUTES 09 SECONDS WEST, CONTINUING ALONG SAID WEST LINE OF RIVER MILL, A DISTANCE OF 751.65 FEET TO A CAPPED REBAR (FAIRHOPE), THENCE RUN SOUTH 89 DEGREES 43 MINUTES 52 SECONDS EAST, A DISTANCE OF 1041.41 FEET TO A CAPPED REBAR (FAIRHOPE), THENCE RUN NORTH 00 DEGREES 19 MINUTES 01 SECONDS EAST, A DISTANCE OF 1284.40 FEET TO A CAPPED REBAR (FAIRHOPE) ON THE aforementioned SOUTH RIGHT-OF-WAY OF FAIRHOPE AVENUE, THENCE RUN NORTH 89 DEGREES 47 MINUTES 51 SECONDS WEST, ALONG SAID SOUTH RIGHT-OF-WAY, A DISTANCE OF 1040.47 FEET TO THE POINT OF BEGINNING. TRACT CONTAINS 30.70 ACRES, MORE OR LESS.

David E. Mehl 01-19-2021
 DAVID E. MEHL AL. P.L.S. NO. 28014 DATE



SURVEY NOT VALID WITHOUT ORIGINAL SIGNATURE AND SEAL.



FLOOD STATEMENT
 PROPERTY LIES IN FLOOD ZONE "X", "X-SHADED", "AE" AND A FLOODWAY AS SCALED FROM FLOOD INSURANCE RATE MAP NUMBER 01050003084A, COMMUNITY NUMBER 015000, PANEL 0864, SUFFIX "M", DATED APRIL 19, 2019.

OVERLAND

A PLANNED UNIT DEVELOPMENT

ZC 21.01
Exhibit A:
Site Plan



Planning Commission recommends approval with conditions. The following votes were tallied:

Ayes - 8
Nays - 0

City of Fairhope City Council June 14, 2021



ZC 21.01 - Overland

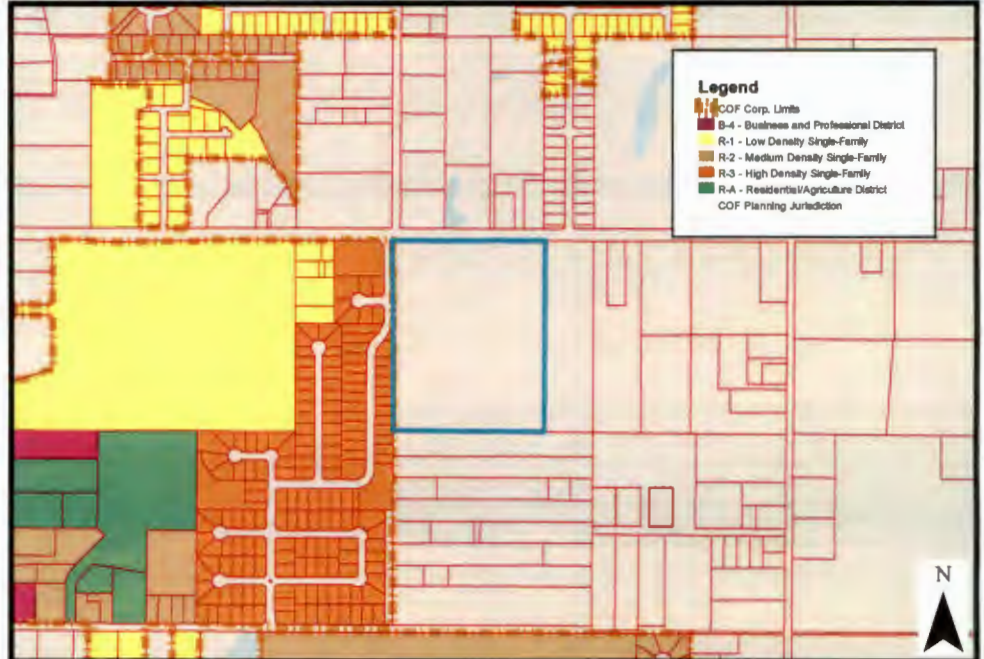

Project Name:

Overland

Site Data:

30.70 acres

Project Type:

Conditional Annexation

Jurisdiction:

Fairhope Planning Jurisdiction

Zoning District:

Unzoned

PPIN Number:

43640

General Location:

Located at the southeast corner of the intersection of County Road 48 and Blueberry Lane, to be known as Overland.

Surveyor of Record:

S.E Civil

Engineer of Record:

S.E Civil

Owner / Developer:

Roberta U. Harris, etal

School District:

Fairhope East Elementary School
Fairhope Middle and High Schools

Recommendation:

Approved with conditions

Prepared by:

Carla Davis

Summary of Request:

The applicant is requesting an initial zoning of PUD (Planned Unit Development) conditional upon annexation. The property is approximately 30.7 acres and is located at the at the southeast corner of the intersection of County Road 48 and Blueberry Lane, to be known as Overland.

The applicant describes the project as a “age-targeted community” for citizens 55 years of age and older; however, they do not plan to restrict buyers under the age of 55. The project consists of 61 Single-Family lots and 16 Townhome Apartments. As proposed, the single-family portion will be accessed by standard streets that will be dedicated to The City of Fairhope. The applicant is proposing 7 different housing layouts with maximum lot coverage of the principal structure not to exceed 45%. The maximum building height will be 30 feet. The minimum house size will be 1,600 square feet with the smallest lot being 6,500 square feet. All the housing designs offer a 2-car garage included in the layout of the home.

The 16-unit townhomes will be accessed by a private asphalt drive and will be a minimum of 1,200 square feet each. The maximum building height will be 35 feet. Exterior materials will consist of hardie board, wood and vinyl eaves. The driveways will be concrete, and each townhome will be accompanied with a single car garage included as a part of the design layout.

The development will utilize City of Fairhope water, sewer and gas services; Baldwin EMC for electrical service; and AT &T for the telephone service. A preliminary utility plan has also been submitted for review.

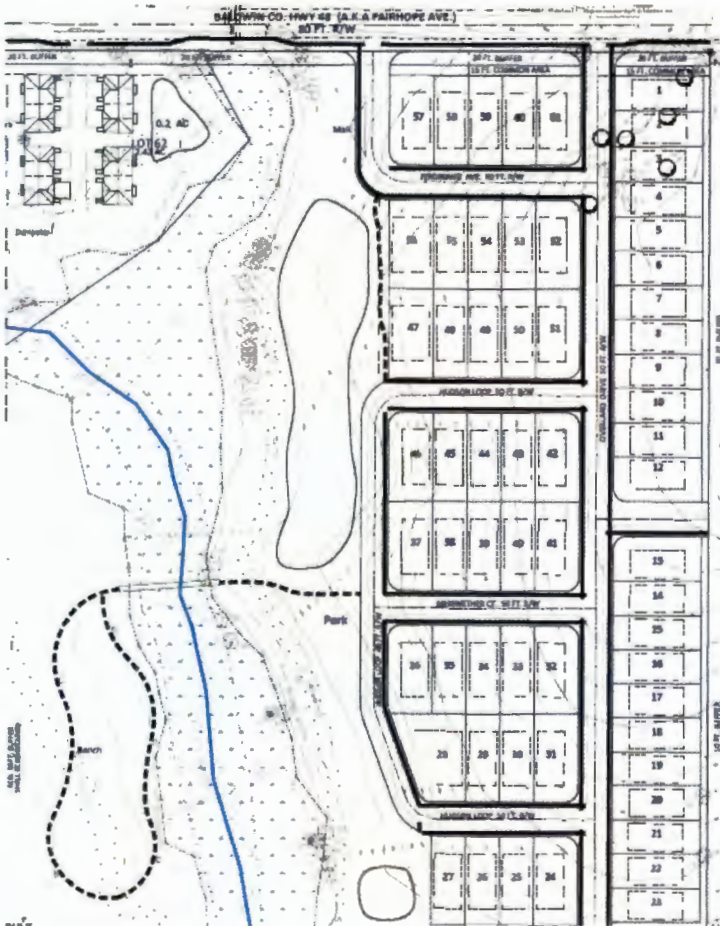

Comments:

The proposed 61 Single-Family dwelling and 16 unit Townhome Apartment development does not seem to be out of character with the surrounding area. It appears that majority of the city’s zoning districts in the area are residential and range from R-3, High Density to R-1, Low Density zonings. There are also additional PUD’s which include both residential and commercial developments. The subject site is near a Village Node as contemplated by the city’s Comprehensive Plan.

Per the site data table, the proposed density for this project is roughly 2.51 units per acre. In the narrative, the applicant referenced other subdivisions within a general vicinity such as River Mill, River Station, Gayfer Estates Plantation, Arlington Farms, Falls Creek, and The Oaks at Fairhope and the overall density requested for this development does appear to keep in line with the neighboring developments. Most of the lots will be 6,500 square feet, with the largest lot being 11,388 square feet. As proposed, lots will be roughly 50’ wide and 130’ in length. The average lot is 7, 087 square feet with 25’ front and rear yard setbacks, and 5’ side yard setback except where there is a corner lot which will be a 20’ side street setback.

Area Neighborhoods

River Mill	Acreage	Lots	Density
Phase 1	15.3	36	2.35
Phase 2	8.92	33	3.70
Phase 3	12.6	32	2.54
Phase 4	19.6	61	3.11
TOTAL	56.42	162	2.87

River Station	Acreage	Lots	Density
Phase 1	9.85	31	3.15
Phase 2	13.01	27	2.08
Phase 3	8.75	27	3.09
TOTAL	31.61	85	2.69

Gayfer Estates Plantation	Acreage	Lots	Density
Phase 1	22.28	47	2.11
Phase 2	16.7	47	2.81
TOTAL	38.98	94	2.41

Arlington Farms	Acreage	Lots	Density
Phase 1	11.07	19	1.72
Phase 2	14.73	22	1.49
TOTAL	25.8	41	1.59

Falls Creek	Acreage	Lots	Density
Phase 1	30.51	62	2.03
TOTAL	30.51	62	2.03

The Oaks at Fairhope	Acreage	Lots	Density
	4.8	50	10.42
TOTAL	4.8	50	10.42

Cumulative Totals	188.1	494	2.63
--------------------------	--------------	------------	-------------

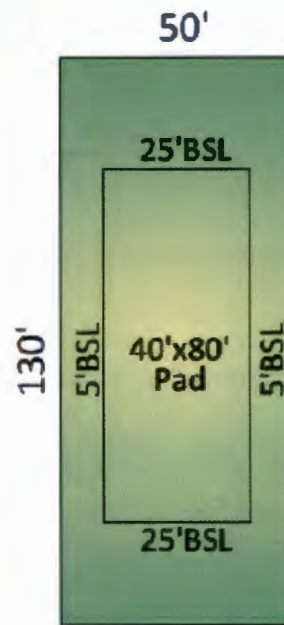

TYPICAL LOT

The site plan illustrates 9.0 acres of greenspace, which is roughly 29.4% of the total site. This exceeds the 15% requirements for greenspace. The total overall common area will be 14.89 acres (48.5%).

The site plan depicts a 10’ buffer along the perimeter of the site. The 20’ greenspace buffer as required per the Tree Ordinance is depicted along Fairhope Avenue and a 15’ common area is also depicted between lots 57-61 and Lot 1. A 6’ wooden privacy fence will be built along the rear lot lines of lots 1-23 at the time of construction (eastern perimeter).

The layout of the site promotes connectivity and provides sidewalks along all street frontages, including a sidewalk on Fairhope Avenue (Hwy 48) with a bridge crossing the wetlands. The plan depicts a mulch trail system, walking bridge to access the proposed nature trail which will also include a park and benches located along the trail. There are also dog waste stations, and pond fountains dispersed throughout the development. If approved, the applicant has an estimated construction start time of 8 months, roughly by November 2021. The development will be constructed as a single phase. A three to five year build out is projected. Townhome apartments are projected for completion by December 2021.

An unsigned copy of the Declaration of Covenants is included within the Master Development Plan. a portion of the Covenants pertaining to sidewalks is inconsistent with City of Fairhope Subdivision Regulations. The portion is listed below:

(c) All sidewalks shall be constructed along the street right-of-way of each lot as noted on the Plat of Subdivision or as required by the City of Fairhope, Alabama. Accordingly, each site plan submitted to the Architectural Review Committee shall show the location and material to be used for construction of the sidewalk, all as required and approved by the Architectural Review Committee. Each owner shall construct or cause to be constructed on his or her Lot approved sidewalk upon completion of the house on his or her lot before occupancy thereof.

The covenants state all sidewalks are to be built by each owner on their lot. Sidewalks are shown within the ROW. Subdivision regulations require sidewalks and street trees to be installed prior to applying for Final Plat approval. Covenants do not override zoning code or subdivision requirements, but in an effort to avoid confusion, staff is memorializing when sidewalks and street shall be installed via a condition of approval.

Fairhope's Zoning Ordinance (Article II Section C.1.e) contains nine (9) criteria by which an application for re-zoning shall be reviewed:

(1) Compliance with the Comprehensive Plan;

Response: Meets. As proposed, the subject property and several surrounding properties are recommended for Residential use by the "Preferred Land Use Plan" as outlined in the 2015 Comprehensive Plan.

(2) Compliance with the standards, goals, and intent of this ordinance;

Response: Meets. This area is identified as a village node, it is important to point out that villages are located at or near the intersections of large corridors, their characteristics will be much different that Downtown Fairhope and other places throughout the city while still promoting connectivity and adequate density.

(3) The character of the surrounding property, including any pending development activity;

Response: Meets. The surrounding area is actively developing with both residential and commercial development.

(4) Adequacy of public infrastructure to support the proposed development;

Response: Meets. As proposed, the development will have City of Fairhope water, sewer and gas services and Baldwin EMC for electric.

(5) Impacts on natural resources, including existing conditions and ongoing post-development conditions;

Response: If approved, the development will go through the subdivision process for which compliance with all regulations will be enforced.

(6) Compliance with other laws and regulations of the City;

Response: If approved, the development will go through the subdivision process for which compliance with all regulations will be enforced.

(7) Compliance with other applicable laws and regulations of other jurisdictions;

Response: N/A.

(8) Impacts on adjacent property including noise, traffic, visible intrusions, potential physical impacts, and property values; and,

Response: Meets. The proposed development does not appear to have any adverse effects to the surrounding area.

(9) Impacts on the surrounding neighborhood including noise, traffic, visible intrusions, potential physical impacts, and property values.

Response: Meets. The proposed development does not appear to have any adverse effects to the surrounding area.

Recommendation:

Staff recommends Case # ZC 21.01 Overland PUD amendment for PPIN 43640 be approved with the following conditions:

1. All sidewalks and streets shall be installed prior to submission of Final Plat Approval, including sidewalk along Fairhope Avenue.

ORDINANCE NO. _____

BE IT ORDAINED BY THE GOVERNING BODY OF THE CITY OF FAIRHOPE, ALABAMA, AS FOLLOWS:

SECTION 1. The City of Fairhope, Alabama, having received an application from **Coca-Cola Bottling Company United** for a franchise agreement to operate **Beverage Vending Machines** at the following location described: **in locations specified in Bid No. 006-21, Beverage Vending and Concessions 2021**, and it is to be in the best interest of the public and the City of Fairhope, Alabama, to grant a franchise to **Coca-Cola Bottling Company United** under the terms and conditions of the franchise agreement attached hereto as "Exhibit A" including the fees that shall be paid to the City with respect to same.

SECTION 2. Pursuant to the authority granted by Section 11-40-1 and 11-43-62 of the Code of Alabama of 1975, the Mayor of the City of Fairhope, Alabama, is hereby directed to execute said franchise agreement in the name of the City of Fairhope, Alabama.

SECTION 3. The sections, paragraphs, sentences, clauses and phrases of this ordinance are severable, and if any phrase, clause, sentence, paragraph or section of this ordinance shall be declared unconstitutional by a court of competent jurisdiction, then such ruling shall not affect any other paragraphs and sections, since the same would have been enacted by the municipality council without the incorporation of any such unconstitutional phrase, clause, sentence, paragraph or section.

SECTION 4. This ordinance shall take effect immediately upon its due adoption and publication as required by law.

ADOPTED THIS 14TH DAY OF JUNE, 2021

Jack Burrell, Council President

ATTEST:

Lisa A. Hanks, MMC
City Clerk

ADOPTED THIS 14TH DAY OF JUNE, 2021

Sherry Sullivan, Mayor

EXHIBIT B

FRANCHISE AGREEMENT

(Amended 10-23-17)

FRANCHISE AGREEMENT

This Agreement is made and entered into by and between the City of Fairhope, Alabama ("City") a municipal corporation and Coca-Cola Bottling Company United - Central, LLC ("Grantee").

RECITALS

Grantee is a sole proprietor with a principal place of business at _____ Fairhope, AL 36532. Grantee is engaged in the business of Beverage Vending to the public. Grantee proposes to install and operate Beverage Vending Machines at the Selected City Locations. Grantee requests that the City grant to Grantee a franchise to install, maintain and operate this business on public property at the agreed upon Vending Locations.

In consideration of the mutual covenants, promises and conditions set forth herein the parties agree as follows:

SECTION 1

Section 1.1 DEFINITIONS

Unless otherwise specially provided, or unless clearly required by the context, the words and phrases defined in this section shall have the following meanings when used in this Ordinance and Franchise Agreement:

- (1) **MAYOR:** Shall mean the Mayor of the City of Fairhope
- (2) **COUNCIL:** Shall mean the City Council of Fairhope, the governing body of City of Fairhope, Alabama.
- (3) **CITY:** Shall mean City of Fairhope, Alabama, which is governed by the Fairhope City Council.
- (4) **FRANCHISE:** Shall mean the franchise granted under the provisions of the Ala. Code §11-40-1, et seq., which authorizes municipalities to contract and to be contracted with. A "franchise" as used in this agreement is a special privilege not belonging to the citizens by common right but conferred by a municipality upon an individual or corporation.
- (5) **GRANTEE:** Shall mean Coca-Cola Bottling Company United - Central, LLC to whom a franchise has been granted by the City or anyone who succeeds Coca-Cola Bottling Company United - Central, LLC, in accordance with the provisions of the franchise.

(6) **GROSS REVENUES:** Shall mean all revenues received by the Grantee from or in connection with the operation of the franchise to provide services in the City of Fairhope pursuant to this franchise agreement.

(7) **PERSON:** Shall mean an individual, partnership, association, joint stock company, trust, corporation, or governmental entity.

(8) **SERVICE AREA:** Shall mean the geographical area within City of Fairhope and specifically defined as follows: City Vending Machine Locations

Section 1.2 REQUIREMENTS FOR FRANCHISE

(a) No person shall engage in the construction, operation, or maintenance of a private business on public property in the City unless such person or the person for whom such action is being taken shall hold a valid franchise granted by the City.

(b) Any franchise granted by the City pursuant to these rules and regulations shall not be deemed to be an exclusive right of permission. The City expressly reserves the right to grant similar nonexclusive franchises to other persons.

(c) In the event the City enters into a franchise, permit, license, authorization, or other agreement of any kind with any other person or entity other than the Grantee to enter into the City's Public Rights-of-way or public property for the purpose of operating a private business on public property in any part of the City, the material provisions thereof shall be reasonably comparable to those contained herein, in order that one operator not be granted an unfair competitive advantage over another, and to provide all parties equal protection under the law.

(d) No franchise shall be granted by the City in the Central Business District located in downtown Fairhope.

(e) No franchise shall be granted by the City to any food vendor who does not show proof of ServSafe certification.

(f) No franchise shall be granted by the City to any vendor requiring a running water supply for personal sanitary purposes and/or for cleaning equipment used in the preparation of his/her product unless water supply is provided and metered by the City.

(g) Food franchises shall meet all Alabama Health Department regulations and show proof thereof.

(h) No franchise shall be granted by the City to any vendor who has electrical requirements without securing metered power from the City or, if applicable, having a generator to supply the power required; generator shall meet City of Fairhope noise ordinances.

Section 1.3 TERM OF FRANCHISE, RENEWAL

(a) The duration of this franchise agreement granted pursuant to this Ordinance shall be for one year and shall be renewed automatically each year for three years unless notice of termination is given in writing to the other party at least 60 days prior to the expiration of the then current term. This Agreement shall commence 10 days

after approved by the City Council.

Section 1.4 ENFORCEMENT OF FRANCHISE

(a) A Grantee shall not be excused from complying with any of the terms or conditions of the franchise by any failure of the City upon any one or more occasions to insist upon or to seek compliance with any such terms or conditions.

(b) Whenever the City shall set forth any time for any action to be performed by or on behalf of Grantee, said time shall be deemed of the essence and any failure of Grantee to perform within the time allotted shall be sufficient grounds for the City to revoke the franchise.

(c) A Grantee agrees by filing an application for a franchise that they will not assert, at any time, in any claim or proceeding that any condition or term of the franchise is unreasonable, arbitrary or void or that the City had no power or authority to make such term or conditions, but shall be required to accept the validity of the terms and conditions of the franchise in their entirety.

Section 1.5 CONFLICT WITH LAWS

(a) Whenever any law of the State of Alabama or of the United States, or of any agency of either, shall be in direct conflict with and supersede any provision of these rules and regulations, then for so long as such state or federal law or regulation shall be in force and effect, any affected provisions of this franchise granted hereunder shall be suspended and be of no force and effect and the Grantee shall not be required to comply with such provision; however, the validity of the remaining portions or provisions shall not be affected thereby. In the event this franchise imposes burdens different than those imposed by any other law, but within the power of the City to impose said burdens, the more restrictive provision shall apply.

(b) If any section, sentence, clause or phrase of these rules and regulations or of any franchise granted hereunder is held unconstitutional or otherwise invalid, such infirmity shall not affect the validity of the remaining portion of these rules and regulations or a of any franchise granted hereunder.

SECTION 2

Section 2.1 PROCEDURE FOR GRANTING FRANCHISE

(a) Any person desiring a franchise shall apply to the City for such a grant. The **application for a franchise** shall be in writing, in the form approved by and containing such information as required by the City and must be accompanied by a nonrefundable **application fee of \$150.00 by cashier's check, certified check or money order payable** to City of Fairhope. This is a separate fee from the Franchise fee.

(b) Upon receipt of said franchise application, the City shall provide notice of said application and conduct a public hearing to determine if the grant of the franchise would be in the best interest of the citizens of City of Fairhope.

(c) The application shall contain a statement under oath that the applicant will comply with all legal, financial and technical provisions of these rules and regulations and any other municipal, state or federal regulatory agencies.

(d) The application shall define the proposed service area of the applicant with specific time standards for the establishment of service to suit the service area.

SECTION 3

Section 3.1 CONSTRUCTION AND INSTALLATION

(a) After receipt of an initial franchise, a Grantee shall proceed with due diligence to install and begin operation of the franchise.

(b) Failure on the part of the Grantee to commence and diligently pursue Beverage Vending or failure to commence operation after 90 days from the commencement of this agreement shall be grounds for termination of the franchise. The City may extend the time for the commencement and completion of Beverage Vending for additional periods in the event the Grantee, acting in good faith, experiences delays by reasons of circumstances beyond her control.

(d) The Vending Machines shall be constructed and operated in accordance with all adopted City, state and national construction and electrical codes.

Section 3.2 CONDITIONS FOR USE OF PUBLIC PROPERTY

(a) Grantee shall not install or begin operation of the franchise business until the installation has been approved by the Mayor or his designee.

Section 3.3 OPERATION AND MAINTENANCE

(a) The Grantee shall install and maintain Beverage Vending in a prudent and reasonable manner.

(b) Failures or malfunctions of the Beverage Vending shall be corrected by the Grantee promptly after notice of such failure or malfunction except or unless such failure or malfunction shall have been caused by storm, fire, lightening, explosion, civil unrest or other similar catastrophe.

(c) The City shall, if it deems it necessary, have the right and privilege to inspect the installation, operation and maintenance of the beverage vending by the Grantee in order to satisfy itself as to the proper performance of the terms of this franchise agreement.

SECTION 4

Section 4.1 FRANCHISE FEE

(a) There shall be a franchise fee of twenty (20) percent of Gross Revenues; and the fee for the business license which is an annual license issued by the municipality for the privilege of doing any kind of business, trade, profession or other activity in the municipality, by whatever name called.

(b) Grantee shall pay quarterly to the City during the life of the franchise a sum equal to twenty (20) percent of its gross revenues. Grantee shall file with the City on such form as prescribed by the City within sixty (60) days after the end of each quarterly a report, under oath at the risk of perjury, of the gross revenues for the preceding quarterly period, and shall, at the same time, pay to the City a sum equal to twenty (20) percent of the gross revenues for the said quarterly period.

Exception #13

Item X, Exhibit B Franchise Agreement, Section 4.2 Indemnifications

United takes exception and proposes the following changes for consistency with the RFP's previous indemnification and insurance sections as redlined below:

a. *Grantee shall at his/her sole cost and expense fully indemnify, defend and save harmless the City, its officers, boards, and employees against any and all claims, demands, suits, actions, liability and judgments for damage arising out of the negligence or willful misconduct of the Grantee in the construction, operation and maintenance of the beverage vending franchise, and against all liabilities for damages by reason of, or arising out of, any failure by Grantee to safely operate and maintain the beverage vending franchise, including reasonable attorney's fees, arising out of the exercise or enjoyment of this franchise, irrespective of the amount of comprehensive liability policy required hereunder. This indemnity shall not apply to damages occasioned solely and exclusively by acts of the City, its agents or employees.*

~~(b)~~ *Within thirty (30) days after the granting of the franchise and at all times during the term of the franchise, Grantee shall obtain, pay all premiums for, and file with the City a Certificate of Insurance for such insurance coverage as set forth in Item VII (INSURANCE) of the Bid 006-21.*

(c) *All of the foregoing insurance certificates shall be in form satisfactory to the City and shall be issued and maintained by companies authorized to do business in the State of Alabama and acceptable to the City and they shall endeavor to provide thirty (30) days written notice of any cancellation or reduction in coverage to both the City and Grantee herein, and a copy of said certificates shall be filed with the City.*

Section 4.2 INDEMNIFICATIONS

(a) Grantee shall at his/her sole cost and expense fully indemnify, defend and save harmless the City, its officers, boards, and employees against any and all claims, demands, suits, actions, liability and judgments for damage arising out of the construction, operation and maintenance of the

franchise, and against all liabilities for damages by reason of, or arising out of, any failure by Grantee to safely operate and maintain the _____, including reasonable attorney's fees, arising out of the exercise or enjoyment of this franchise, irrespective of the amount of comprehensive liability policy required hereunder. This indemnity shall not apply to damages occasioned solely and exclusively by acts of the City, its agents or employees.

(b) Within thirty (30) days after the granting of the franchise and at all times during the term of the franchise, Grantee shall obtain, pay all premiums for, and file with the City executed duplicate copies and receipts evidencing the payment of premiums for the following:

A general comprehensive public liability insurance policy indemnifying, defending and saving harmless the City, its officers, boards, agents or employees from any and all claims by any person whatsoever on account of injury to or death of a person or persons occasioned by the operations of the Grantee under franchise herein granted or alleged to have been so caused with a minimum of liability of _____ for personal injury or death of any two or more persons in any one occurrence. Renewal certificates of such insurance shall be promptly forwarded to the City as such renewals are made, and such insurance shall be kept in force and effect during the term of this grant or franchise. The Grantee and/or the insurance company shall file with the City a written notice of any material alteration or cancellation of any insurance coverage at least thirty (30) days prior to the effective date of such alteration or cancellation. Property damage insurance indemnifying, defending and saving harmless the City, its officers, boards, agents, and employees from and against all claims by any person whatsoever for property damage occasioned by the operation of a Grantee under franchise granted by _____ City caused with a minimum liability of _____ for property damage to two or more persons in any one occurrence. Said policies of insurance shall name the City as an additional insured.

(c) All of the foregoing insurance certificates shall be in form satisfactory to the City and shall be issued and maintained by companies authorized to do business in the State of Alabama and acceptable to the City and they shall require thirty (30) days written notice of any cancellation or reduction in coverage to both the City and Grantee herein, and a copy of said certificates shall be filed with the City.

Section 4.3 BOOKS/RECORDS OF GRANTEE

(a) All books and records of a Grantee concerning its operations within the City necessary for the enforcement of the provisions of this franchise, shall be made available for inspection and audit upon demand by the City within thirty (30) days after any request for such inspection or audit has been made.

Section 4.4 GRANTEE ACKNOWLEDGEMENT

(a) Grantee is an independent contractor. No agency or employment relationship is created by this Franchise Agreement.

SECTION 5

Section 5.1 SALE OR LEASE OF FRANCHISE

(a) No transfer or control of the Beverage Vending, whether by force or voluntary sale, lease, assignment, foreclosure, attachment, merger, or any other form of disposition, shall occur or be considered valid without first giving prior notice and receiving the approval of the City. The notice shall include full identifying particulars of the proposed transaction. For the purpose of determining whether it shall consent to such change, transfer, or acquisition of control, the City may inquire into the qualification of the prospective controlling party and the Grantee shall assist the City in any such inquiry. The City shall have one 60 days from the date the notice is received by the City within which to approve or disapprove, by resolution, the proposed transfer of control. The City will not unreasonably withhold its approval.

(b) Approval of such transfer shall be expressly conditioned upon full compliance with the material terms of the franchise agreement and this Ordinance. The transferee shall agree in writing to comply with all provisions of this Ordinance and the franchise agreement.

Section 5.2 REVOCATION OF FRANCHISE

(1) Subject to the provisions of this section, the City reserves the right to revoke, at any time, any franchise granted hereunder and rescind all rights and privileges associated therewith in the event that:

(a) Grantee has not substantially complied with a material provision of this Ordinance, the franchise agreement, or of any supplemental written agreement entered into by and between the City and the Grantee; or

(b) Grantee has made a material false statement in the application for the franchise, knowing it to be false, or Grantee commits a fraud in its conduct or relations under the franchise with the City; or

(c) Grantee becomes insolvent, enters into receivership or liquidation, files for bankruptcy or assignment for benefits of creditors, or is unable to pay its debts as they mature, unless the Grantee is in due process of contesting such debts; or

(d) Grantee fails to substantially comply with a material provision of any federal or state statute, or of any material rules or regulations that govern telecommunications; or

(e) Grantee exhibits a pattern of failing to comply with service standards as adopted herein or in the franchise agreement; or

(f) Grantee fails to comply with any federal or state judgment arising directly from the exercise of Grantee's rights under its franchise; or

(g) Grantee fails to provide or maintain in full force and effect the bond and insurance policies required by this Ordinance and franchise agreement; or

(h) Grantee assigns, sells or transfers its title or interest in its franchise without the consent of the City.

(2) In the event that the City shall make a preliminary decision to revoke a franchise granted hereunder, it shall give the Grantee a minimum of thirty days written notice of its intention to terminate and stipulate cause. A public hearing shall be scheduled for the end of said 30-day period. If during said period, the cause shall be cured to the satisfaction of the City, the City shall declare the notice to be null and void. If the cause is not cured to the satisfaction of the City, before a franchise may be terminated, the Grantee must be provided with an opportunity to be heard before the City in a public hearing in accordance with due process procedures. After the public hearing, if the City, by majority vote,

determines that the franchise should be terminated, it shall issue a written decision containing its findings of fact and stating the specific grounds for termination. The decision to terminate a franchise shall be subject to judicial review as provided by law.

(3) A Grantee shall not be declared in default or be subject to any sanction under any provision of this Ordinance and franchise agreement in any case where the City determines that the action justifying such sanction is without the Grantee's knowledge or authorization or outside its control.

Section 5.3 RIGHTS UPON REVOCATION OR NON-RENEWAL

In the event the City determines that a franchise should not be renewed at its expiration or that a franchise should be revoked for cause as permitted hereunder, the Grantee shall be allowed three months from the date of such determination, or such longer period as the City may permit, to negotiate the sale of its beverage vending within the City to another provider at a price acceptable to the Grantee, provided that such sale shall be approved by the City pursuant to Section 5 herein. In the event a sale to a provider acceptable to the City is not then negotiated within the time allowed, then an independent expert shall be appointed to

determine the fair market value of the Grantee's beverage vending. The appointment of said expert shall be by mutual agreement between the City and the Grantee; provided, however, that if the City and the Grantee are unable to reach an agreement within 30 days of the written decision of termination, then the matter of appointing an expert shall be submitted, within ten (10) days immediately following expiration of the former 30 days, to the American Arbitration Association [unless the City and the Grantee mutually agree upon some other arbitrator(s)], and the expert designated by the American Arbitration Association or such other arbitrators shall be appointed. The cost of employing the arbitrator or arbitrators and the cost of arbitration, if required, shall be borne equally by the Grantee and the City. Upon determination of the fair market value of the Grantee's Beverage Vending by the appointed independent expert, the Grantee shall be required to sell its beverage vending to any entity which offers said fair market value and which has obtained the approval of the City to purchase said beverage vending.

Section 5.4 REMOVAL AND ABANDONMENT OF PROPERTY

(a) If the use of any part of Grantee's beverage vending is discontinued for any reason for a continuous period of twelve (12) months, or if such beverage vending does not comply with the requirements of these rules and regulations, or if Grantee's franchise is terminated or revoked the City may in its discretion require that said _____ be sold to a franchise designated by the City at a purchase price equal to the _____ fair market value as determined in subsection (b) hereof.

Our equipment cannot be resold and belongs to Coca-Cola Bottling Company United Central, LLC at all times

(b) Any dispute between the City and the Grantee over determination of the system's fair market value shall be determined in accordance with Section 5.3 above.

Section 5.5 MISCELLANEOUS PROVISIONS

(a) This agreement constitutes the entire agreement of the parties and supersedes any and all agreements, understandings, statements or representations either oral or in writing. This agreement can be amended only by a written document signed by the parties.

(b) This agreement shall be enforced and interpreted pursuant to the laws of the State of Alabama.

IN WITNESS WHEREOF, the Parties have hereunto set their respective signatures and seals on the ____ day of _____, 20__.

THE CITY OF FAIRHOPE, ALABAMA

By: _____
Sherry Sullivan, Mayor

Attest: _____
Lisa A. Hanks, MMC
City Clerk

By: _____
, Grantee

RESOLUTION NO. 3972-21

BE IT RESOLVED BY THE GOVERNING BODY OF THE CITY OF FAIRHOPE, ALABAMA, as follows:

[1] That the City of Fairhope did request, receive, and open bids for Beverage Vending and Concessions 2021 – Three Year for the Recreation Department for the Recreation Department (Bid Number 006-21) at 555 South Section Street in the City of Fairhope offices, Fairhope, Alabama.

[2] At the appointed time and place, the bids were opened and tabulated.

[3] After evaluating the bid proposals with the required bid specifications, only one valid bid was received and we request that all bids be rejected for Beverage Vending and Concessions 2021 – Three Year for the Recreation Department Bid No. 006-21; and authorize the Mayor to negotiate a contract with the one bidder, pursuant to the Code of Alabama 1975, Section 39-2-6(b).

Adopted on this 8th day of February, 2021

Jack Burrell, Council President

Attest:

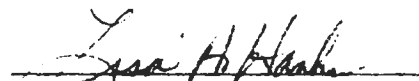
Lisa A. Hanks, MMC
City Clerk

ORDINANCE NO. _____

**AN ORDINANCE DIRECTING THE TRANSFER OF LAND
TO BALDWIN COUNTY, ALABAMA AND DECLARING
SAID PROPERTY TO BE SURPLUS AND NOT NEEDED
FOR PUBLIC OR MUNICIPAL PURPOSES LOCATED AT
INTERSECTION OF COUNTY ROAD 13 AND COUNTY
ROAD 32 IMPROVEMENT 05-46-08-33-0-000-009.000
TRACT NUMBER 1**

BE IT ORDAINED BY THE GOVERNING BODY OF THE CITY OF
FAIRHOPE, ALABAMA, AS FOLLOWS:

Section 1. The legal description of the real estate that is the subject matter of this Ordinance is in Baldwin County, Alabama and is more particularly described as follows:

A part of the Southeast Quarter of the Southeast Quarter of Section 33, Township 6 South, Range 2 East, identified as Tract Number 1 on County Road 13 at County Road 32 Intersection Improvement Project No. 0222219/HW19222000 in Baldwin County, Alabama and being more fully described as follows:

Parcel 1 of 1:

Commencing at a BCHD set concrete monument found at the southeast corner of the Southeast Quarter of Section 33, Township 6 South, Range 2 East, in Baldwin County, Alabama;

Thence N89°53'02"W along the south line of said Section a distance of 109.81 feet to a point;

Thence N0°00'00"W leaving the south line of said Section a distance of 49.98 feet to the grantor's property corner and being the Point of Beginning of the property herein to be conveyed;

Thence N89°53'02"W along the grantor's south property line a distance of 83.97 feet to a point on the acquired R/W line (said point is offset 54.58 feet left of and perpendicular to project centerline of County Road 32 at Station 34+73.00);

Thence N40°57'59"E along the acquired R/W line a distance of 205.28 feet to a point on the grantor's east property line (said point is offset 54.54 feet right of and perpendicular to project centerline of County Road 13 at Station 44+74.03);

Thence S0°13'32"W along the grantor's east property line a distance of 105.35 feet to the grantor's property corner;

Thence S45°12'43"W along the grantor's property line a distance of 70.73 feet to the Point of Beginning of the property herein conveyed and containing 0.210 acres, more or less.

Ordinance No. _____
Page -2-

Section 2. The City Council of the City of Fairhope has determined that the proposed roundabout to be built on said property will serve a public purpose allowing easier ingress and egress to the City's future sports fields and increase traffic safety at said intersection. The City Council hereby authorizes the Mayor to execute all necessary deeds and documentation to donate said described land to Baldwin County, Alabama for the public purpose of a roundabout to be constructed at said intersection.

Section 3. The sections, paragraphs, sentences, clauses and phrases of this ordinance are severable, and if any phrase, clause, sentence, paragraph or section of this ordinance shall be declared unconstitutional by a court of competent jurisdiction, then such ruling shall not affect any other paragraphs and sections, since the same would have been enacted by the municipality council without the incorporation of any such unconstitutional phrase, clause, sentence, paragraph or section.

Section 4. This ordinance shall take effect immediately upon due adoption and publication as required by law.

Adopted and approved this 14th day of June, 2021

Jack Burrell, Council President

Attest:

Lisa A. Hanks, MMC
City Clerk

Adopted and approved this 14th day of June, 2021

Sherry Sullivan, Mayor

And as shown on the right of way map of record in the Baldwin County Highway Department, a copy of which is also deposited in the office of the Judge of Probate as an aid to persons and entities interested therein and as shown on the Property Sketch attached hereto and made a part hereof.

TO HAVE AND TO HOLD, unto Baldwin County, Alabama, its successors and assigns in fee simple forever.

AND FOR THE CONSIDERATION AFORESAID, I (we) do for myself (ourselves), for my (our) heirs, executors administrators, successors, and assigns covenant to and with Baldwin County, Alabama, that I (we) am (are) lawfully seized and possessed in fee simple of said tract or parcel of land hereinabove described; that I (we) have a good and lawful right to sell and convey the same as aforesaid; that the same is free of all encumbrances, liens, and claims, except the lien for ad valorem taxes which attached on October 1, last past, and which is to be paid by the grantor; and that I (we) will forever warrant and defend the title thereto against the lawful claims of all persons whomsoever.

THE GRANTOR(S) HEREIN FURTHER COVENANT(S) AND AGREE(S), that the purchase price above-stated is in full compensation to him-her (them) for this conveyance.

IN WITNESS WHEREOF, I (we) have hereunto set my (our) hand(s) and seal this the _____ day of _____, 2021.

City of Fairhope, Alabama
an Alabama municipal corporation

By: _____
Sherry Sullivan, Its Mayor

Attest:

By: _____
Lisa A. Hanks, MMC
Its City Clerk

ACKNOWLEDGMENT FOR CORPORATION

STATE OF ALABAMA)

COUNTY OF BALDWIN)

I, _____, a Notary Public, in and for said County in said State, hereby certify that Sherry Sullivan, whose name as Mayor of the City of Fairhope, Alabama, an Alabama municipal corporation and Lisa A. Hanks, whose name as City Clerk of the City of Fairhope, Alabama, an Alabama municipal corporation, are signed to the foregoing conveyance and who are known to me, acknowledged before me on this day that, being informed of the contents of this conveyance, they, as such officers and with full authority, executed the same voluntarily for and as the act of said municipal corporation.

Given under my hand and official seal this _____ day of _____, 2021.

NOTARY PUBLIC

Commission Expires: _____

GRANTEE'S ADDRESS:

BALDWIN COUNTY HIGHWAY DEPARTMENT
P.O. BOX 220
SILVERHILL, ALABAMA 36576

**WAIVER OF RIGHTS TO APPRAISAL AND JUST COMPENSATION
AND RIGHT-OF-ENTRY**

**COUNTY ROAD 13 AT COUNTY ROAD 32
INTERSECTION IMPROVEMENT
PROJECT NO. 0222219/HW19222000
BALDWIN COUNTY, ALABAMA
TRACT 1**

I (We) the undersigned property owner(s) do hereby acknowledge that I (we) have been made aware of my (our) rights to an appraisal and just compensation and in further consideration of the benefits accrued to my (our) property from the above-referenced project, I (we) do hereby waive my (our) rights to said appraisal and just compensation and grant right-of-entry for the construction of same.

IN WITNESS WHEREOF, we have hereunto set our hands and seals on this the _____ day of _____, 2021.

**City of Fairhope, Alabama
an Alabama municipal corporation**

By: _____
Sherry Sullivan, Its Mayor

Attest:

By: _____
Lisa A. Hanks, MMC
Its City Clerk

ACKNOWLEDGMENT FOR CORPORATION

STATE OF ALABAMA)

COUNTY OF BALDWIN)

I, _____, a Notary Public, in and for said County in said State, hereby certify that Sherry Sullivan, whose name as Mayor of the City of Fairhope, Alabama, an Alabama municipal corporation and Lisa A. Hanks, whose name as City Clerk of the City of Fairhope, Alabama, an Alabama municipal corporation, are signed to the foregoing conveyance and who are known to me, acknowledged before me on this day that, being informed of the contents of this conveyance, they, as such officers and with full authority, executed the same voluntarily for and as the act of said municipal corporation.

Given under my hand this _____ day of _____, 2021.

NOTARY PUBLIC

My Commission Expires: _____

ORDINANCE NO. _____

AN ORDINANCE OF THE CITY OF FAIRHOPE REPEALING AND REPLACING SECTION 21-21 BY THE ADOPTION OF THE FOLLOWING ELECTRIC RATES FOR ALL CUSTOMERS OF THE CITY

BE IT ORDAINED BY THE GOVERNING BODY OF THE CITY OF FAIRHOPE, ALABAMA, as follows:

SECTION ONE. Code of Ordinances, City of Fairhope, Alabama, Chapter 21 Utilities and Services, Section 21-21, is hereby repealed and replaced as per the following monthly rates:

Section. 21-21. - Rates—Regular service.

(a) *Base rates.* The following monthly rates for all electric customers served by the city:

- (1) *Residential R1:* Applicable to single residences, individually metered mobile homes, and individual family apartments where cost of service is paid by the occupant.

Customer Charge: \$13.00 per month (Minimum), plus
First 3000 KWH/month @ \$0.103660, plus
All Over 3000 KWH/month @ \$0.114540, plus FCA & Tax

- (2) *Commercial C1:* Applicable to nonresidential power service where the maximum fifteen-minute interval integrated demand does not exceed 49 kw.

Customer Charge: \$33.50 per month (minimum), plus
All KWH/month @ \$0.109907, plus FCA & tax

- (3) *Industrial I1:* Applicable to nonresidential electric service where the maximum fifteen-minute interval integrated demand is 50 kw or more.

Customer Charge: \$82.00 per month (minimum), plus
Demand: All demand @ \$8.46 per KW/month; minimum demand is 75% of highest demand imposed during preceding 11 months, but not less than 38 KW = \$321.44, plus

Energy:
First 20,000 KWH/month @ \$0.084817, plus
All Over 20,000 KWH/month @ \$0.079081, plus FCA & tax

- (4) *Hospital H1.* Applicable to hospital electric service where the maximum 15-minute interval integrated demand is 500 KW or more.

Customer Charge: \$82.00 per month (Minimum), plus
Demand: All demand @ \$8.46 per KW/month; minimum demand is 75% of highest demand imposed during preceding 11 months, but not less than 38 KW = \$321.44, plus

Energy:
First 20,000 KWH/month @ \$0.08480, plus
All Over 20,000 KWH/month @ \$0.0720, plus FCA & tax

- (5) *Schools M1:* Applicable to public and private primary and secondary schools, regardless of size of their electrical requirements.

Customer Charge: \$13.00 per month (minimum), plus
All KWH/month @ \$0.103660, plus FCA & tax

- (6) *Eleemosynary M2*: Applicable to churches and nonprofit organizations who receive the majority of their support from charitable contributions.

Customer Charge: \$13.00 per month (minimum), plus
 All KWH/month @ \$0.103660, plus FCA & tax

- (7) *Eleemosynary M2I*: Applicable to churches and non-profit organizations who receive the majority of their support from charitable contributions where the maximum 15-minute interval integrated demand is fifty (50) KW or more.

Customer Charge: \$13.00 per month (Minimum), plus
 Demand: All Demand @ \$3.80 per KW/month; Minimum Demand is 75% of highest demand imposed during preceding 11 months, but not less than 38 KW = \$144.30, plus
 Energy: ALL KWH/month @ \$0.058323, plus FCA & Tax

- (8) *City use M3*: Applicable only to City of Fairhope accounts and departments.

ALL KWH @ \$0.10287 per KWH, plus FCA & tax, if not exempt. No minimum, plus FCA & tax.

- (9) *Security lights*: The following monthly security light rentals assume city ownership of treated pine pole, mounting brackets and hardware, open lighting fixture lamp, photoelectric control, and one (1) span of # six (6) aluminum overhead duplex cable. Customers shall be billed for additional installation costs for equipment and work which exceed the above standard installation. Customers shall be responsible for all charges due to vandalism or abuse.

Metal halide or mercury	Lumens	Monthly rental, plus tax.
175 W.	8,600	\$ 9.58
250 W.	12,100	\$13.71
400 W.	22,500	\$21.91

High pressure sodium:	Lumens	Monthly rental, plus tax.
100 W.	9,500	\$ 9.58
150 W.	15,000	\$ 8.21
200 W.	22,000	\$11.55
250 W.	22,500	\$13.71
400 W.	50,000	\$21.91

LED	Monthly rental, plus tax.
XNV	\$ 8.17
XNV2	\$13.65

- (10) *Temporary or seasonal service surcharge*: When commercial or industrial service is provided for a period of less than one (1) year continuously or is seasonal or temporary, a surcharge of twenty-five (25) per cent shall be added to each month's bill, before applying tax, after the bill has been computed in accordance with the applicable rate schedule. No monthly minimum or other charge is to be made during the period that service is disconnected. For each nonrecurring temporary service where it is necessary for a temporary service pole to be set and/or a temporary service drop to be installed from existing utility facilities, the city may assess additional charges to recover the cost of installing and removing such service.

- (11) *Tax*: The four (4) per cent Alabama Utilities Gross Receipts Tax is applicable to all rates, except exempt accounts of city, state, and federal governments. Should any other state or federal tax be levied, it shall be charged in addition.

- (b) *Schedule FCA.* Schedule FCA shall provide for the monthly fluctuation in wholesale "fuel adjustment cost" changes as currently reflected in the monthly purchased power invoice received from the Alabama Municipal Electric Authority ("AMEA"). In the event schedule FCA results in a negative factor, such negative FCA factor shall be applied to each customer's monthly bill. All FCA factors shall be rounded off to the nearest one-thousandth of a mill (\$0.000000).

The FCA shall be calculated from the total current billing period's wholesale fuel adjustment charges billed from supplier(s) and then billed at retail by the city, as follows:

$$FCA = (F+A)/R$$

Where:

F = Total estimated wholesale supplier fuel adjustment charges to be billed during the coming billing period(s) in dollars.

A = Adjustment to reflect any over/under recovery of the FCA during previous billing period(s) in dollars.

R = Total retail kWh sales estimated to be billed during the coming billing period(s).

- (c) *Labor cost adjustment (LCA) factor.* The base rates set forth above may be adjusted periodically to account for permanent changes in labor-related revenue requirements (c.g., salaries and wages, pensions, and benefits, etc.) that come about as a result of budget actions taken by the city council for a fiscal year. Such adjustment, when approved by the city council, shall be calculated as follows:

$$LCA = 1 + ((TLCB - TLCBR)/BRRR)$$

Where:

TLCB = The total annual labor cost, in dollars, that is reflected in the electric utility budget for the coming fiscal year, as approved by the City Council.

TLCBR = The total annual labor cost, in dollars, that is reflected in the current base electric rates.

BRRR = The total estimated revenue requirement, in dollars, that is being recovered in current base rates.

The LCA factor so calculated shall be applied to each retail rate set forth above, excluding schedule FCA, such that it will result in new base electric rates. Thus, when applied, a new TLCBR and BRRR will be established for future LCA calculations. The following accounts shall be used in the determination of total labor costs as reflected in TLCB and TLCBR:

Collection costs/revenue department

Administrative costs

Salaries

Payroll taxes

Retirement expense

Medical insurance

Casualty/workers compensation insurance

- (d) *Definitions.*

(1) *Billing period:* may include the coming monthly billing period or, if the City so elects, the six-month levelization period fuel cost adjustment as currently offered by AMEA.

(2) *Supplier fuel adjustment charges:* Current period fuel adjustment charges by all wholesale suppliers.

- (3) *Retail kWh sales:* Total estimated billing period retail kWh sales recorded by the city to all residential customers, schools, churches, nonprofit organizations, commercial and industrial customers. Sales recorded by the city as sales to various city departments and facilities, except the water and sewer department, shall be excluded from retail kWh sales. Estimated kWh consumption associated with non-metered security lights shall also be excluded.

(c) *General rules and regulations.*

Payment: Bills are payable within ten (10) days from due date and, if not paid within such period, may be increased as determined by the mayor and council.

Service and metering: Service to more than one (1) premise shall not be combined, nor shall it be shared with or resold to others. Any customer receiving service at two (2) different voltages or metering points will be considered as two (2) separate customers for billing purposes. The type and location of metering is to be specified by the city. Rates in subsection (a) contemplate city ownership of transformation facilities; however, rental or ownership of transformation by an industrial customer is subject to negotiation by and with the city.

(f) *Wholesale rate fluctuation.* If the wholesale rate goes up or down, the wholesale percentage will be passed through to the retail customer.

SECTION TWO. All Ordinances that adopted Section 21-21 are hereby repealed and replaced by this Ordinance.

SECTION THREE. The sections, paragraphs, sentences, clauses, and phrases of this ordinance are severable, and if any phrase, clause, sentence, paragraph, or section of this ordinance shall be declared unconstitutional by a court of competent jurisdiction, then such ruling shall not affect any other paragraphs and sections, since the same would have been enacted by the municipality council without the incorporation of any such unconstitutional phrase, clause, sentence, paragraph or section.

SECTION FOUR. This ordinance shall take effect on August 1, 2021 upon its due adoption and publication as required by law.

Effective on October 1, 2022, the Customer Charge (base rate) for all customers will increase \$2.00 per month.

Effective on October 1, 2023, the Customer Charge (base rate) for all customers will increase an additional \$2.00 per month.

ADOPTED THIS 14TH DAY OF JUNE, 2021

Jack Burrell, Council President

ATTEST:

Lisa A. Hanks, MMC
City Clerk

ADOPTED THIS 14TH DAY OF JUNE, 2021

Sherry Sullivan, Mayor

RESOLUTION NO. _____

BE IT RESOLVED BY THE GOVERNING BODY OF THE CITY OF FAIRHOPE, ALABAMA, that the City Council authorizes Mayor Sherry Sullivan to execute the American Recue Plan Act Agreement between the City of Fairhope and the United States Department of the Treasury for the Coronavirus State and Local Fiscal Recovery Funds in the amount of \$1,941,458.00 to be used in compliance with section 603(c) of the Social Security Act, Treasury's regulations implementing that section, and guidance issued by Treasury regarding the foregoing.

DULY ADOPTED THIS 14TH DAY OF JUNE, 2021

Jack Burrell, Council President

ATTEST:

Lisa A. Hanks, MMC
City Clerk

OMB Approved No. 1505-0271
Expiration Date: November 30, 2021

U.S. DEPARTMENT OF THE TREASURY
CORONAVIRUS STATE AND LOCAL FISCAL RECOVERY FUNDS

Recipient name and address: <i>City of Fairhope</i> P O Drawer 429, Fairhope, AL 36533	DUNS Number: 071935902 Taxpayer Identification Number: 63-6001254 Assistance Listing Number: 21.019
---	---

Sections 602(b) and 603(b) of the Social Security Act (the Act) as added by section 9901 of the American Rescue Plan Act, Pub. L. No. 117-2 (March 11, 2021) authorize the Department of the Treasury (Treasury) to make payments to certain recipients from the Coronavirus State Fiscal Recovery Fund and the Coronavirus Local Fiscal Recovery Fund.

Recipient hereby agrees, as a condition to receiving such payment from Treasury, to the terms attached hereto.

Recipient:

Authorized Representative:

Title:

Date signed:

U.S. Department of the Treasury:

Authorized Representative:

Title:

Date:

PAPERWORK REDUCTION ACT NOTICE

The information collected will be used for the U.S. Government to process requests for support. The estimated burden associated with this collection of information is 15 minutes per response. Comments concerning the accuracy of this burden estimate and suggestions for reducing this burden should be directed to the Office of Privacy, Transparency and Records, Department of the Treasury, 1500 Pennsylvania Ave., N.W., Washington, D.C. 20220. DO NOT send the form to this address. An agency may not conduct or sponsor, and a person is not required to respond to, a collection of information unless it displays a valid control number assigned by OMB.

U.S. DEPARTMENT OF THE TREASURY
CORONAVIRUS LOCAL FISCAL RECOVERY FUND
AWARD TERMS AND CONDITIONS

1. Use of Funds.
 - a. Recipient understands and agrees that the funds disbursed under this award may only be used in compliance with section 603(c) of the Social Security Act (the Act), Treasury's regulations implementing that section, and guidance issued by Treasury regarding the foregoing.
 - b. Recipient will determine prior to engaging in any project using this assistance that it has the institutional, managerial, and financial capability to ensure proper planning, management, and completion of such project.
2. Period of Performance. The period of performance for this award begins on the date hereof and ends on December 31, 2026. As set forth in Treasury's implementing regulations, Recipient may use award funds to cover eligible costs incurred during the period that begins on March 3, 2021, and ends on December 31, 2024.
3. Reporting. Recipient agrees to comply with any reporting obligations established by Treasury as they relate to this award.
4. Maintenance of and Access to Records
 - a. Recipient shall maintain records and financial documents sufficient to evidence compliance with section 603(c) of the Act, Treasury's regulations implementing that section, and guidance issued by Treasury regarding the foregoing.
 - b. The Treasury Office of Inspector General and the Government Accountability Office, or their authorized representatives, shall have the right of access to records (electronic and otherwise) of Recipient in order to conduct audits or other investigations.
 - c. Records shall be maintained by Recipient for a period of five (5) years after all funds have been expended or returned to Treasury, whichever is later.
5. Pre-award Costs. Pre-award costs, as defined in 2 C.F.R. § 200.458, may not be paid with funding from this award.
6. Administrative Costs. Recipient may use funds provided under this award to cover both direct and indirect costs.
7. Cost Sharing. Cost sharing or matching funds are not required to be provided by Recipient.
8. Conflicts of Interest. Recipient understands and agrees it must maintain a conflict of interest policy consistent with 2 C.F.R. § 200.318(c) and that such conflict of interest policy is applicable to each activity funded under this award. Recipient and subrecipients must disclose in writing to Treasury or the pass-through entity, as appropriate, any potential conflict of interest affecting the awarded funds in accordance with 2 C.F.R. § 200.112.

9. Compliance with Applicable Law and Regulations.
- a. Recipient agrees to comply with the requirements of section 603 of the Act, regulations adopted by Treasury pursuant to section 603(f) of the Act, and guidance issued by Treasury regarding the foregoing. Recipient also agrees to comply with all other applicable federal statutes, regulations, and executive orders, and Recipient shall provide for such compliance by other parties in any agreements it enters into with other parties relating to this award.
 - b. Federal regulations applicable to this award include, without limitation, the following:
 - i. Uniform Administrative Requirements, Cost Principles, and Audit Requirements for Federal Awards, 2 C.F.R. Part 200, other than such provisions as Treasury may determine are inapplicable to this Award and subject to such exceptions as may be otherwise provided by Treasury. Subpart F – Audit Requirements of the Uniform Guidance, implementing the Single Audit Act, shall apply to this award.
 - ii. Universal Identifier and System for Award Management (SAM), 2 C.F.R. Part 25, pursuant to which the award term set forth in Appendix A to 2 C.F.R. Part 25 is hereby incorporated by reference.
 - iii. Reporting Subaward and Executive Compensation Information, 2 C.F.R. Part 170, pursuant to which the award term set forth in Appendix A to 2 C.F.R. Part 170 is hereby incorporated by reference.
 - iv. OMB Guidelines to Agencies on Governmentwide Debarment and Suspension (Nonprocurement), 2 C.F.R. Part 180, including the requirement to include a term or condition in all lower tier covered transactions (contracts and subcontracts described in 2 C.F.R. Part 180, subpart B) that the award is subject to 2 C.F.R. Part 180 and Treasury's implementing regulation at 31 C.F.R. Part 19.
 - v. Recipient Integrity and Performance Matters, pursuant to which the award term set forth in 2 C.F.R. Part 200, Appendix XII to Part 200 is hereby incorporated by reference.
 - vi. Governmentwide Requirements for Drug-Free Workplace, 31 C.F.R. Part 20.
 - vii. New Restrictions on Lobbying, 31 C.F.R. Part 21.
 - viii. Uniform Relocation Assistance and Real Property Acquisitions Act of 1970 (42 U.S.C. §§ 4601-4655) and implementing regulations.
 - ix. Generally applicable federal environmental laws and regulations.
 - c. Statutes and regulations prohibiting discrimination applicable to this award include, without limitation, the following:
 - i. Title VI of the Civil Rights Act of 1964 (42 U.S.C. §§ 2000d et seq.) and Treasury's implementing regulations at 31 C.F.R. Part 22, which prohibit discrimination on the basis of race, color, or national origin under programs or activities receiving federal financial assistance;

- ii. The Fair Housing Act, Title VIII of the Civil Rights Act of 1968 (42 U.S.C. §§ 3601 et seq.), which prohibits discrimination in housing on the basis of race, color, religion, national origin, sex, familial status, or disability;
 - iii. Section 504 of the Rehabilitation Act of 1973, as amended (29 U.S.C. § 794), which prohibits discrimination on the basis of disability under any program or activity receiving federal financial assistance;
 - iv. The Age Discrimination Act of 1975, as amended (42 U.S.C. §§ 6101 et seq.), and Treasury's implementing regulations at 31 C.F.R. Part 23, which prohibit discrimination on the basis of age in programs or activities receiving federal financial assistance; and
 - v. Title II of the Americans with Disabilities Act of 1990, as amended (42 U.S.C. §§ 12101 et seq.), which prohibits discrimination on the basis of disability under programs, activities, and services provided or made available by state and local governments or instrumentalities or agencies thereto.
10. Remedial Actions. In the event of Recipient's noncompliance with section 603 of the Act, other applicable laws, Treasury's implementing regulations, guidance, or any reporting or other program requirements, Treasury may impose additional conditions on the receipt of a subsequent tranche of future award funds, if any, or take other available remedies as set forth in 2 C.F.R. § 200.339. In the case of a violation of section 603(c) of the Act regarding the use of funds, previous payments shall be subject to recoupment as provided in section 603(e) of the Act.
11. Hatch Act. Recipient agrees to comply, as applicable, with requirements of the Hatch Act (5 U.S.C. §§ 1501-1508 and 7324-7328), which limit certain political activities of State or local government employees whose principal employment is in connection with an activity financed in whole or in part by this federal assistance.
12. False Statements. Recipient understands that making false statements or claims in connection with this award is a violation of federal law and may result in criminal, civil, or administrative sanctions, including fines, imprisonment, civil damages and penalties, debarment from participating in federal awards or contracts, and/or any other remedy available by law.
13. Publications. Any publications produced with funds from this award must display the following language: "This project [is being] [was] supported, in whole or in part, by federal award number [enter project FAIN] awarded to [name of Recipient] by the U.S. Department of the Treasury."
14. Debts Owed the Federal Government.
- a. Any funds paid to Recipient (1) in excess of the amount to which Recipient is finally determined to be authorized to retain under the terms of this award; (2) that are determined by the Treasury Office of Inspector General to have been misused; or (3) that are determined by Treasury to be subject to a repayment obligation pursuant to section 603(e) of the Act and have not been repaid by Recipient shall constitute a debt to the federal government.
 - b. Any debts determined to be owed the federal government must be paid promptly by

Recipient. A debt is delinquent if it has not been paid by the date specified in Treasury's initial written demand for payment, unless other satisfactory arrangements have been made or if the Recipient knowingly or improperly retains funds that are a debt as defined in paragraph 14(a). Treasury will take any actions available to it to collect such a debt.

15. Disclaimer.

- a. The United States expressly disclaims any and all responsibility or liability to Recipient or third persons for the actions of Recipient or third persons resulting in death, bodily injury, property damages, or any other losses resulting in any way from the performance of this award or any other losses resulting in any way from the performance of this award or any contract, or subcontract under this award.
- b. The acceptance of this award by Recipient does not in any way establish an agency relationship between the United States and Recipient.

16. Protections for Whistleblowers.

- a. In accordance with 41 U.S.C. § 4712, Recipient may not discharge, demote, or otherwise discriminate against an employee in reprisal for disclosing to any of the list of persons or entities provided below, information that the employee reasonably believes is evidence of gross mismanagement of a federal contract or grant, a gross waste of federal funds, an abuse of authority relating to a federal contract or grant, a substantial and specific danger to public health or safety, or a violation of law, rule, or regulation related to a federal contract (including the competition for or negotiation of a contract) or grant.
- b. The list of persons and entities referenced in the paragraph above includes the following:
 - i. A member of Congress or a representative of a committee of Congress;
 - ii. An Inspector General;
 - iii. The Government Accountability Office;
 - iv. A Treasury employee responsible for contract or grant oversight or management;
 - v. An authorized official of the Department of Justice or other law enforcement agency;
 - vi. A court or grand jury; or
 - vii. A management official or other employee of Recipient, contractor, or subcontractor who has the responsibility to investigate, discover, or address misconduct.
- c. Recipient shall inform its employees in writing of the rights and remedies provided under this section, in the predominant native language of the workforce.

17. Increasing Seat Belt Use in the United States. Pursuant to Executive Order 13043, 62 FR 19217 (Apr. 18, 1997), Recipient should encourage its contractors to adopt and enforce on-the-job seat belt policies and programs for their employees when operating company-owned, rented or personally owned vehicles.

18. Reducing Text Messaging While Driving. Pursuant to Executive Order 13513, 74 FR 51225 (Oct. 6, 2009), Recipient should encourage its employees, subrecipients, and contractors to adopt and enforce policies that ban text messaging while driving, and Recipient should establish workplace safety policies to decrease accidents caused by distracted drivers.

RESOLUTION NO. _____

**RESOLUTION OF THE CITY COUNCIL OF THE CITY OF FAIRHOPE, ALABAMA,
APPROVING AND CONSENTING TO THE CERTIFICATE OF AMENDMENT
OF THE FAIRHOPE AIRPORT AUTHORITY**

WHEREAS, Fairhope Airport Authority was duly formed and incorporated by the City of Fairhope, Alabama by the execution and recordation of a Certificate of Incorporation on or about March 6, 2007; and

WHEREAS, Pursuant to Code of Alabama, 1975, § 4-3-44, the Authority does hereby AMEND its Certificate of Formation (filed for record on March 6, 2007 as Instrument Number 1035291 in the Office of the Judge of Probate of Baldwin County, Alabama) to change the residency requirements for Directors specified in the Certificate; and

WHEREAS, the City Council of the City has reviewed the contents of the Certificate of Amendment, including the proposed residency requirements as follows: the residency requirements are amended according to the attached Certificate of Amendment to state that four (4) Directors must reside within the corporate limits of the City of Fairhope, Alabama and three (3) Directors may reside within the corporate limits of the City of Fairhope or within the Baldwin County Board of Education School Zone which services any Fairhope Elementary School, Fairhope Intermediate School, or J. Larry Newton School according to the 2020 School Zone Map prepared by the Baldwin County Board of Education and attached and made a part of this Resolution.

NOW, THEREFORE, BE IT RESOLVED by the City Council of the City, in a regular meeting of the City Council, that the Proposed Certificate of Amendment is hereby approved as set forth in the Authority's Resolution and under the provisions of the Title 4, Chapter 3, Article 2, Code of Alabama, 1975."

Adopted this the 14th day of June, 2021

Jack Burrell, Council President
City of Fairhope, Alabama

ATTEST:

Lisa A. Hanks, MMC
City Clerk

**RESOLUTION TO APPROVE
AMENDMENT TO CERTIFICATE OF INCORPORATION**

BE IT HEREBY RESOLVED by the Board of Directors of Fairhope Airport Authority, an airport authority incorporated pursuant to § 4-3-40, et seq., Ala. Code 1975, as follows:

1. Pursuant to § 4-3-44, Ala. Code 1975, the Authority does hereby AMEND its Certificate of Formation (filed for record on March 6, 2007 as Instrument Number 1035291 in the Office of the Judge of Probate of Baldwin County, Alabama) to change the residency requirements for Directors specified in the Certificate.

2. The residency requirements are AMENDED according to the attached Certificate of Amendment to state that FOUR (4) Directors must reside within the corporate limits of the City of Fairhope, Alabama and THREE (3) Directors must reside within a Baldwin County Board of Education School Zone which services any Fairhope Elementary School, Fairhope Intermediate School, or J. Larry Newton School according to the **2020** School Zone Map prepared by the Baldwin County Board of Education and attached and made a part of this Resolution.

3. The Authority shall request that the City of Fairhope, Alabama, as the appropriate authorizing subdivision, adopt an appropriate resolution consent to the Certificate of Amendment as set forth in this Resolution.

4. The attached Certificate of Amendment is hereby APPROVED.

5. The original, executed Certificate of Amendment, together with a certified copy of this Resolution and a certified copy of the Resolution to be adopted by the City Council of the City of Fairhope, Alabama, shall be recorded in the Office of the Judge of Probate of Baldwin County, Alabama, as required by § 4-3-44, Ala. Code 1975.

Done this 8th day of June, 2021.

Don Lagarde, Chairman

William Bruce, Secretary

**CERTIFICATE OF AMENDMENT TO
CERTIFICATE OF INCORPORATION OF
FAIRHOPE AIRPORT AUTHORITY**

WHEREAS, Fairhope Airport Authority was duly formed and incorporated by the City of Fairhope, Alabama by the execution and recordation of a Certificate of Incorporation on or about March 6, 2007;

WHEREAS, the Certificate of Incorporation is recorded as Instrument Number 1035291 in the records of the Office of the Judge of Probate of Baldwin County, Alabama;

WHEREAS, Fairhope Airport Authority was formed and incorporated under the authority of § 4-3-40, et seq., Ala. Code 1975 (being the same as Title 4, Chapter 3, Article 2, Ala. Code 1975);

WHEREAS, the current Directors of the Authority are: Don Lagarde (Chairman); Frank T. Groner (Vice Chairman); William Bruce (Secretary); Amy Pearson (Treasurer); Vince Boothe (Board Member); and Jack Burrell (Council Liaison, Board Member); and

WHEREAS, the Directors of the Authority determine that it is in the best interest of the Authority to AMEND the Certificate of Incorporation for the limited purpose of modifying the residency requirements in Paragraph 7 of the Certificate of Incorporation.

NOW THEREFORE, KNOW ALL MEN BY THESE PRESENTS, that the Certificate of Incorporation of Fairhope Airport Authority is hereby AMENDED as follows:

1. The Board of Directors of the Authority shall consist of seven (7) members who shall be elected in the manner and for the term of office provided by law, at least FOUR (4) Directors must reside within the corporate limits of the City of Fairhope, Alabama and THREE (3) Directors must reside within a Baldwin County Board of Education School Zone which services any Fairhope Elementary School, Fairhope Intermediate School, or J. Larry Newton School according to the 2020 School Zone Map prepared by the Baldwin County Board of Education and attached and made a part of this Resolution.

2. Future modifications to the 2020 School Zone Map by the Baldwin County Board of Education, if any, shall not modify the boundaries or the residency requirements established by this Certificate of Amendment.

3. Except as modified by Paragraphs 1 and 2, above, the Certificate of Incorporation remains unmodified, and in full force and effect.

IN WITNESS WHEREOF, the Directors of Fairhope Airport Authority have hereunto subscribed their signatures on this 8th day of June, 2021.

FAIRHOPE AIRPORT AUTHORITY

Don Lagarde, Chairman

Section 4-3-45**Board of directors of authority.**

Each authority shall be governed by a board of directors of either three, five, or seven members as provided in the certificate of incorporation or the bylaws. If the sole authorizing subdivision is a county, the county commission of the county shall elect all directors. If the sole authorizing subdivision is a municipality, the governing body of such municipality shall elect all directors. The directors initially elected shall be elected for terms of office of two, four, and six years, respectively, and their successors shall be elected for terms of six years. If a county and a municipality are both authorizing subdivisions, the governing body of the municipality shall elect one director for an initial term of two years if three directors are to be elected, and one director for an initial term of two years and one director for an initial term of four years if five directors are to be elected, and one for an initial term of two years and one for an initial term of four years and one for an initial term of six years if seven directors are to be elected, the county commission shall elect one director for an initial term of four years if three directors are to be elected, and one director for an initial term of two years and one director for an initial term of four years if five directors are to be elected, and one for an initial term of two years and one for an initial term of four years and one for an initial term of six years if seven directors are to be elected. The governing bodies of the county and the municipality shall agree on the third, fifth, or seventh director, whose term of office shall be for six years. In the event of a vacancy in the office of such third, fifth, or seventh director which continues for more than 30 days, then and in such event the Governor shall, upon the request of any one or more of such authorizing subdivisions, appoint the additional director. The term of office of all directors except those initially elected shall be for a term of six years.

Except in the case of the election of directors for an existing public airport authority reincorporated hereunder, election of directors by the governing body of a municipality shall be on the nomination of the mayor. Except in the case of the election of directors for an existing public airport authority reincorporated hereunder, election of directors by the county commission of a county shall be on the nomination of the judge of probate. If the certificate of incorporation shall so provide, any member of the county commission of a county which is an authorizing subdivision or the governing body of the municipality which is an authorizing subdivision shall be eligible for election as director. If the certificate of incorporation shall so provide, the mayor of the municipality which is the authorizing subdivision or the judge of probate of the county which is an authorizing subdivision or both such mayor and such judge of probate if both a county and a municipality are authorizing subdivisions shall *ex officio* be entitled to notice of each special or called meeting and to attend all meetings of the board, but shall have no right to vote at any such meeting and shall not be considered in determining a quorum. If any director resigns, dies or becomes incapable or ineligible to act as a director, a successor to serve the unexpired portion of his term shall be elected in the manner prescribed in this section by the governing body which elected the director whose unexpired term he is filling or, in the case of the additional member, by the governing bodies of both the county and the municipality and, failing such election for a period of more than 30 days shall be appointed by the Governor upon the request of any such governing body. In the event any director ceases to be a director of the authority prior to the expiration of the term of office, a successor shall serve for the unexpired term of office. If the term of office of any director of an authority expires prior to the appointment of a successor, the director shall continue to serve for so long as necessary until a successor is appointed and qualified. Directors shall be eligible to succeed themselves. No director, officer, or employee of an authority shall be personally liable for any debt, obligation, or liability of the authority.

The current directors of an existing public airport authority reincorporated hereunder shall retain full authority to act during the period between the time such airport authority shall file a certificate of reincorporation and the time the authorizing subdivisions elect all the directors of such airport authority in the manner prescribed in this section.

A majority of the directors shall constitute a quorum of the board for the transaction of business, but any meeting of the board may be adjourned from time to time by a majority of the directors present or may be so adjourned by a single director if such director is the only director present at such meeting. No vacancy in the membership of the board shall impair the right of a quorum to exercise all the powers and duties of the authority. The board shall hold an annual meeting and such other regular meetings as may be provided in the bylaws of the authority, and the board may hold other meetings at any time from time to time; provided, that upon call of the chairman of the authority or any two directors, a special meeting of the board must be held. Any matter on which the board is authorized to act may be acted upon at any regular, special, or called meeting. At the request of any director, the vote on any question before the board shall be taken by yeas and nays and entered upon the record.

All proceedings of the board shall be reduced to writing by the secretary of the authority, recorded in a well-bound book and open to each director and to the public at all times. Copies of such proceedings, when certified by the secretary of the authority under its seal, shall be received in all courts as evidence of the matters and things therein certified.

Each director shall be reimbursed for expenses actually incurred by him in and about the performance of his duties. Each director may also be compensated by the authority in an amount authorized by the bylaws. The authorizing subdivision or subdivisions shall have the authority to rescind any increase in compensation authorized by the bylaws, but such action shall be taken within the first 30 days from the date of the action by the authorizing subdivision. Upon notice from the authorizing subdivision or subdivisions, any increase in compensation shall be rescinded, effective with the next compensation payment due to the directors. Following rescission by the authorizing subdivision or subdivisions, the directors' compensation shall return to the amount of compensation in effect immediately prior to any such increase.

Any director of the authority may be impeached and removed from office in the same manner and on the same grounds provided by Section 175 of the Constitution of Alabama of 1901, and the general laws of the state for impeachment and removal of the officers mentioned in Section 175.

(Acts 1977, No. 331, p. 433, §6; Acts 1987, No. 87-778, p. 1528; Acts 1991, No. 91-268, p. 499, §2; Act 2006-558, p. 1283, §1.)

CURRENT

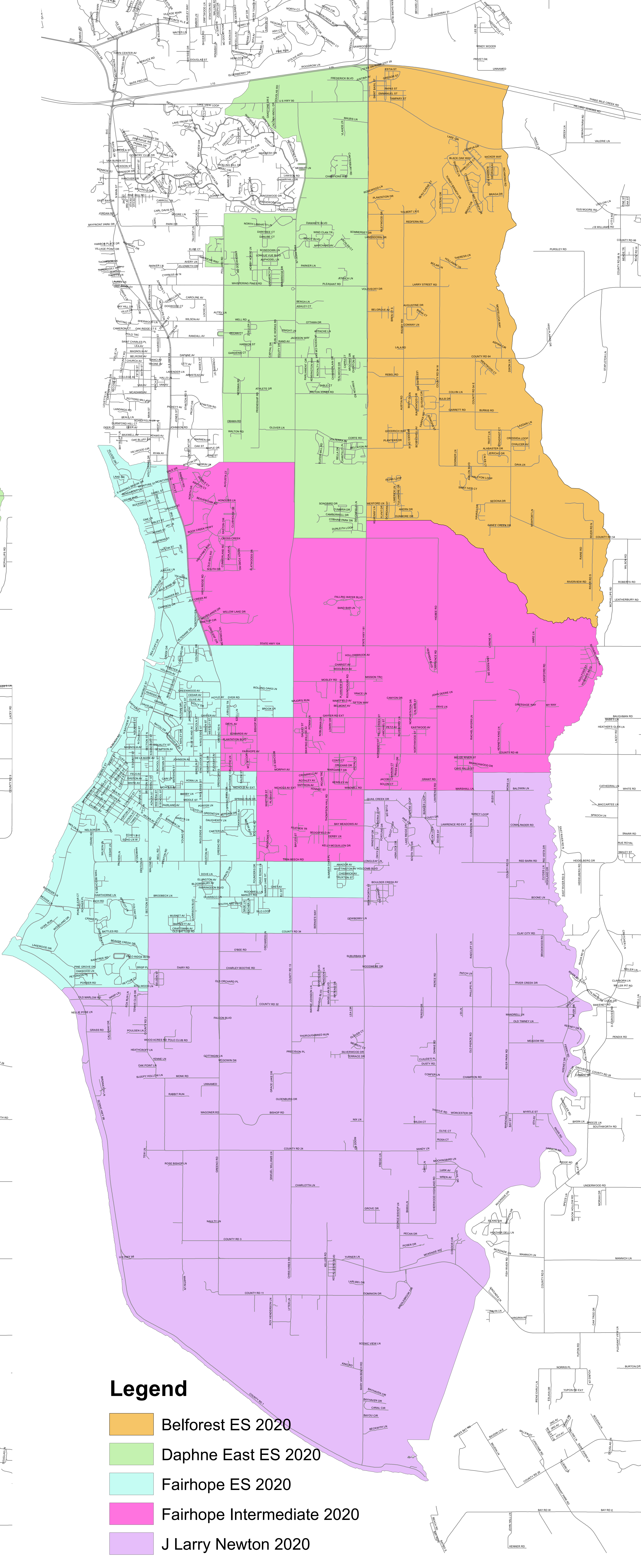
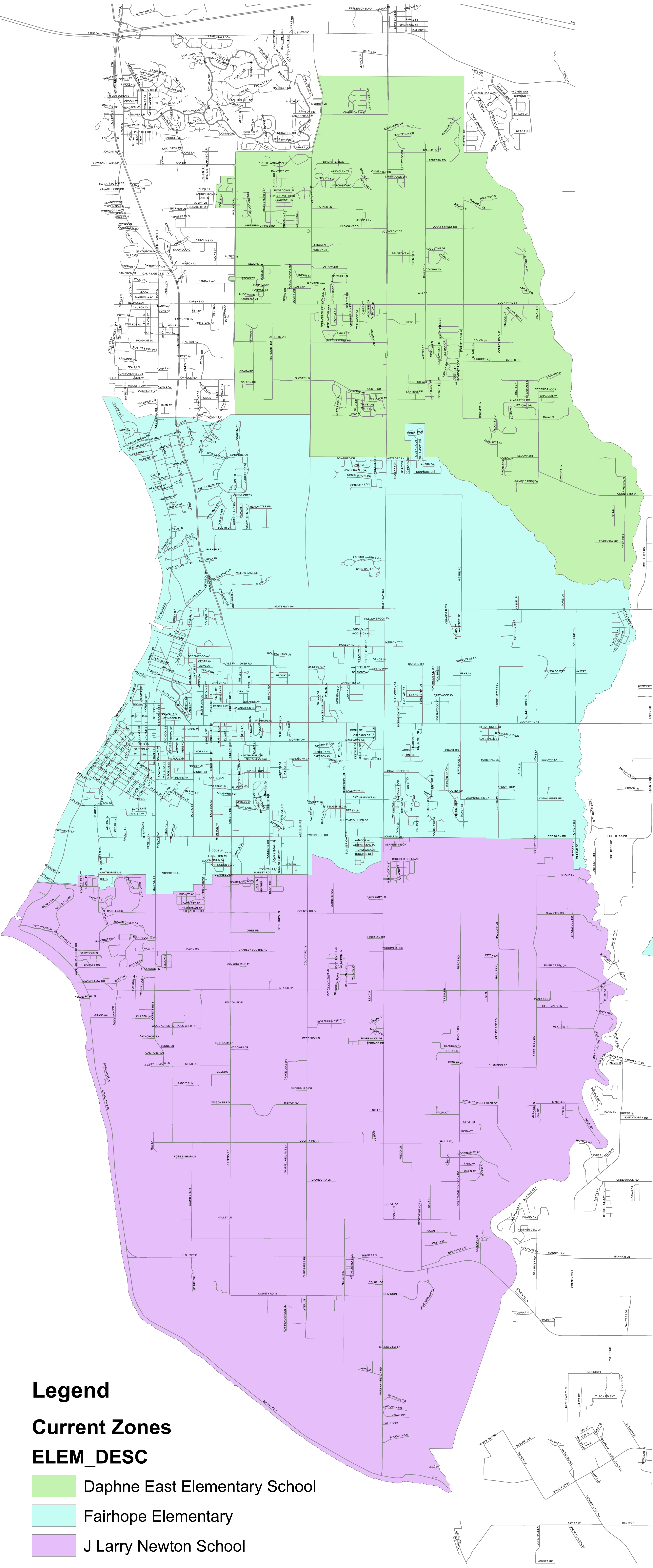

2020



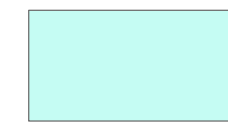

Legend

Current Zones

ELEM_DESC

-  Daphne East Elementary School
-  Fairhope Elementary
-  J Larry Newton School

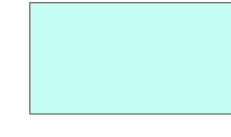
Legend

-  Belforest ES 2020
-  Daphne East ES 2020
-  Fairhope ES 2020
-  Fairhope Intermediate 2020
-  J Larry Newton 2020

RESOLUTION NO. ____

BE IT RESOLVED BY THE GOVERNING BODY OF THE CITY OF FAIRHOPE, ALABAMA, That the City Council approves the selection of Kimley-Horn to perform Professional Consulting Services for the New Water Transmission Line on County Road 33 (RFQ No. PS014-21); and hereby authorizes Mayor Sherry Sullivan to negotiate a fee schedule and establish a not-to-exceed limit with this firm.

DULY ADOPTED THIS 14TH DAY OF JUNE, 2021

Jack Burrell, Council President

Attest:

Lisa A. Hanks, MMC
City Clerk



City of Fairhope
2/14

MEMO

To: Kimberly Creech, City Treasurer

Sherry Sullivan
Mayor

From: Delores A Brandt
Delores A Brandt, Purchasing Manager

Date: May 24, 2021

Re: **City Council Approval of Mayor's choice of professional service provider RFQ No. PS014-21 Professional Consulting Services for New Water Transmission Line on CR 33 for the Water Department. This is a budgeted item for FY2021 and FY2022**

Council Members:

Kevin G. Boone
Jack Burrell, ACMO
Jimmy Conyers
Corey Martin
Jay Robinson

Lisa A. Hanks, MMC
City Clerk

Kimberly Creech
Treasurer

The Water Department needs to hire a professional consulting firm for **RFQ PS014-21 Professional Consulting Services for New Water Transmission Line on CR 33**. Mayor Sullivan chose **Kimley Horn** to perform the professional services for the project. The new water line project will increase water capacity supplied from well field/treatment plant #3 to our storage tanks on Fairhope Avenue which will also increase capacity to the south. It is expected to take 24 months to complete. The estimated cost will be split over FY21 and FY22 with \$900,000.00 budgeted for FY21.

Please move this request forward for City Council to approve the Mayor's selection of Kimley-Horn for RFQ PS014-21 Professional Consulting Services for New Water Transmission Line on CR 33 and approve for the Mayor to negotiate the not-to-exceed fee.

Cc: file, Jason Langley, Mayor Sullivan

161 North Section St.
PO Drawer 429
Fairhope, AL 36533

251-928-2136 (p)
251-928-6776 (f)
www.fairhopeal.gov



MEMO

Sherry Sullivan
Mayor

Council Members:
Kevin G. Boone
Jay Robinson
Jack Burrell, ACMO
Jimmy Conyers
Corey Martin

Lisa A. Hanks, MMC
City Clerk

Kimberly Creech
Treasurer

To: Lisa Hanks, MMC City Clerk
Kimberly Creech, Treasurer

From: Delores A Brandt
Delores A Brandt, Purchasing Manager

Date: May 20, 2021

Re: **Choosing RFQ PS Professional Consultant for New Water Transmission Line—County Rd 33**

The Water and Wastewater Superintendent, Jason Langley, is requesting engineering services related to the New Water Transmission Line on Country Road 33. This will increase the water capacity supplied from Well Field/Treatment Plant 3 to Fairhope Avenue. This will enhance our water capacity significantly moving available water from Treatment Plant # 3 to our storage tanks on Fairhope Avenue. This will also increase capacity to the south as well. This project is estimated at \$1.9 million to be split over 2 years.

Per our Procedure for Procuring Professional Services I am routing this short list through you, to the Mayor. Please move this procurement of professional services forward to the Mayor for selection of professional service provider(s) to receive the RFQ.

The short list is:

[Mayor, please initial and date your selection]

Sh Sullivan 5/20/21

_____ / / _____

_____ / / _____

_____ / / _____

_____ / / _____

Kimley-Horn

Volkert, Inc

Mott MacDonald

JADE Consulting

Sain Associates—Consulting Eng
and Surveyors

161 North Section St.
PO Box 429
Fairhope, AL 36533

Cc: file, Jason Langley

FIRM QUALIFICATIONS

Kimley-Horn is a full service consulting firm that has a wide range of expertise. Kimley-Horn will provide the City of Fairhope with the quality of work and focused dedication that is desired for each and every project. Listening to the City's needs, understanding your vision, and providing the technical resources necessary to meet your expectations is essential for any project to be truly successful.

The **Kimley-Horn** team is prepared to assist the City of Fairhope in their Water and Wastewater project needs and has the required experience in the following Water and Wastewater service areas:

- Alternative water supply strategies
- Advanced water and wastewater treatment
- Aquifer storage and recovery (ASR)
- Asset management
- Biological/hydraulic modeling of wastewater process systems
- Chemical engineering
- Civil engineering
- Complex utility relocations
- Condition assessments
- Construction administration and observation services
- Design of trenchless pipelines
- Flood control and floodplain mapping
- Geographic information systems (GIS)
- Groundwater wells and modeling
- Grant funding assistance
- Hydraulic modeling of water and wastewater systems
- Infiltration and inflow studies and sewer rehabilitation
- Master planning
- Mechanical engineering
- Monitoring and reporting
- Permit compliance
- Piping
- Process evaluations
- Pump station design (W/WW)
- Reclaimed water distribution systems
- Reclaimed water storage and pumping systems
- Regulatory assistance
- Route evaluations and alternatives
- Sanitary sewer collection system design
- Sanitary sewer force main design
- STEP systems
- Surface water treatment
- Value engineering
- Water and wastewater treatment
- Water transmission and distribution system design

WATER SYSTEM DESIGN AND PERMITTING

Kimley-Horn's specific water system design capabilities encompass all planning, design, permitting, and construction phase services required from the onset of a project through the approval process, and then bringing the system online. We have completed a large number of successful design projects, including new water mains, relocations, pumping stations, and metering stations. Our services routinely include designing under strict regulatory compliance conditions, coordinating with existing utilities to avoid underground conflicts, and integrating with existing on-site systems.

WATER MODELING AND MASTER PLANNING

Accurate planning for water system expansion is necessary to provide quality water to the City's customers at the optimum service level. Kimley-Horn's modeling experts know how to make the most of existing data to predict how your facilities will perform. Our models, including those prepared in WaterCad, can show you how to remedy an existing problem or how to phase small improvements to maximize system efficiency. We work with your existing maps and GIS, and our extensive in-house library of modeling software can simulate your entire range of field conditions. Our engineers and scientists will expertly build and calibrate a model to assist with tasks ranging from projecting capital budgets to planning for plant operations during normal and high-flow demands, optimizing the City's system operations to minimize capital and operating expenditures. Our water modeling services provide value by helping to ensure adequate water pressure and demands are met, water age is improved through more efficient flushing programs, and master planning properly accounts for future developments and expansions.

WATER TREATMENT EXPERTISE

Kimley-Horn's staff of professionals possess award-winning experience in the planning and design of water treatment systems, including groundwater wells, master pumping stations, disinfection, and water storage facilities. The firm's water treatment expertise ranges from systems as simple as aeration/disinfection to reverse osmosis, membrane softening, ion exchange, and distillation; our capabilities encompass all planning, design, permitting, and construction observation services required from the onset of a project through the approval process to plant startup, operational testing, and training.

MEMBRANE EXPERIENCE

The Kimley-Horn project team has extensive membrane experience and the expertise to address tough treatment issues. From pilot testing to direct purchase and testing of membrane systems, our team has the expertise and industry know-how to provide support on any membrane issue. We have demonstrated this expertise with many of our utility clients and provide some of the following services, just to name a few:

- Membrane projections and performance evaluation
- Preparation of technical specifications
- Pilot testing programs
- Procurement methods
- Cleaning of membranes
- Basic membrane operation training
- Manufacturer collaboration
- Technical support
- Start-up Assistance
- Membrane autopsies evaluations
- Membrane treatment system design

WASTEWATER TREATMENT

Kimley-Horn has a reliable history of wastewater treatment plant (WWTP) design and permitting, rehabilitations and expansions, advanced treatment technologies, master planning, smart BNR/process control design, wastewater lagoons, constructed wetlands, WWTP biological and hydraulic modeling, condition assessment, process optimization, effluent disposal, and biosolids processing. Our nationwide treatment practice has served clients in numerous states bringing the best practices from multiple regions to new clients. We have helped our clients alter processes to prepare for regulatory changes to negotiate permits, optimize processes, evaluate operation and maintenance costs for various treatment technologies, and perform master planning for existing facilities.

An important factor in modifying wastewater systems is listening to staff and operations personnel. Oftentimes projects need to be designed to maintain operation of the existing facilities while bringing the new facilities online. Kimley-Horn has extensive experience in the industry to provide you with the expert advice and guidance needed to efficiently complete your projects on time and within budget.

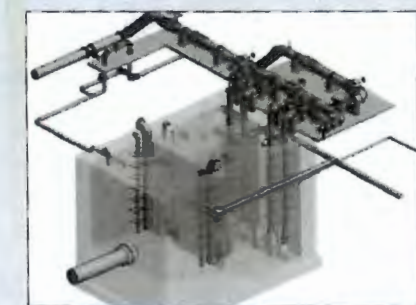
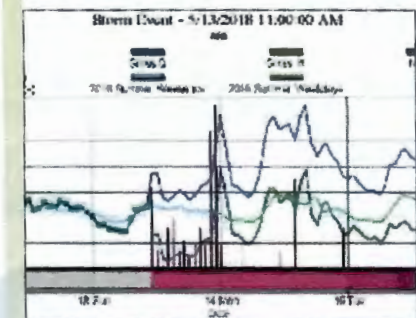
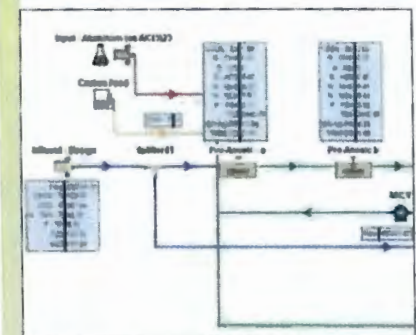

WASTEWATER PUMP STATIONS, COLLECTION, AND TRANSMISSION SYSTEMS

The Kimley-Horn team's wastewater experience includes collection system evaluation and design. We have a growing list of collection system condition assessment projects, including flow monitoring, infiltration and inflow (I/I) assessments, smoke and dye testing, hydraulic modeling, rehabilitation/replacement recommendation, capital improvement planning, master planning, rate studies, pipe lining, pipe bursting, bypass pumping, trenchless construction, lift station assessment and improvements, and odor and corrosion inspection and control. Kimley-Horn has a wide range of experience in the rehabilitation of sanitary pump stations, collection systems, and force main systems. We have designed new pump stations to replace old and outdated stations, as well as complete renovations/rehabilitations of pump stations in their current location—all while keeping the station operational throughout the renovation/rehabilitation process. Our experience includes design of stations with capacities from 0.1-MGD to more than 100-MGD for a variety of applications across the nation. We cover all facets of the design and construction phase process, including mechanical system design, force main/collection system design, structural engineering, hydraulic modeling, permitting, telemetry, and SCADA system design. Kimley-Horn offers proven experience in the layout, design, route selection, and construction of wastewater collection mains and force mains for public agencies. Our team has designed hundreds of miles of sewer lines ranging in size from six inches to 72 inches. Many of these designs have facilitated the extension of utility services to communities that were previously unserved.

MODELING AND MASTER PLANNING

Whether you're trying to determine a more efficient way to move wastewater around the plant site or master planning for a major system expansion, Kimley-Horn's modeling experts know how to make the most of existing data to predict how your facilities will perform. We work with your existing maps and GIS databases to generate models to develop plans to address existing constraints or to develop recommendations on how best to phase improvements to maximize system efficiency. Our extensive in-house library of modeling software can simulate your entire range of field conditions. Our engineers and scientists will expertly build and calibrate a model to help you with tasks ranging from projecting capital budgets and planning for plant operations during normal and emergency situations to optimizing system operations to minimize capital and operating expenditures.

MODELING CAPABILITIES

- Water/reclaimed/sewer pipeline systems
- Steady state and extended period simulation
- Wastewater process and hydraulic modeling
- Pipeline transient analysis
- Develop pump control strategies
- Analyze and compare rehabilitation alternatives
- Analyze available fireflows
- Identify high and low pressure zones
- Existing and projected population loading
- Analyze age of water
- Develop hydrant flushing plans

MODELING SOFTWARE

- WaterCAD/WaterGEMS
- SewerCAD/SewerGEMS
- InfoWater
- Mike Urban
- BioWIN
- Hammer
- ICPR
- SWMM
- StormCAD
- Infosewer or Infoworks ICM

RESOLUTION NO. _____

BE IT RESOLVED BY THE GOVERNING BODY OF THE CITY OF FAIRHOPE, ALABAMA, That the City Council approves the selection of Stewart Engineering, Inc. to perform Professional Engineering Services for System Study for the Electric Department (RFQ No. PS012-21); and hereby authorizes Mayor Sherry Sullivan to negotiate a fee schedule and establish a not-to-exceed limit with this firm.

DULY ADOPTED THIS 14TH DAY OF JUNE, 2021

Jack Burrell, Council President

Attest:

Lisa A. Hanks, MMC
City Clerk



MEMO

5/14/21
JAH

To: Kimberly Creech, Treasurer
From: Delores A Brandt
Delores A Brandt, Purchasing Manager

Sherry Sullivan
Mayor

Date: May 14, 2021

Council Members
Kevin G. Boone
Robert A. Brown
Jack Burrell, ACOM
Jimmy Conyers
Corey Martin

Re: **Council approval to Award contract for RFQ PS012-21 Professional Consulting Services for System Study for Electric Dept**

Lisa A. Hanks, MMC
City Clerk

The Superintendent of Utilities, Mayor Sullivan and the Electric Dept Assistant Superintendent, Jeremy Morgan, have need to hire a professional consulting firm for **RFQ PS012-21 Professional Consulting Services for System Study for Electric Dept.** The consultation project will involve the determination of the proper loading and conductor size for the City's electric system.

Kimberly Creech
City Treasurer

The new consulting services are budgeted in the budget for FY2021 in the amount of \$100,00.00.

Per the City's "Procedure for Procuring Professional Services the Superintendent of Utilities, and the Electric Dept Assistant Superintendent and I routed a short list of firms from which the Mayor was to choose. She selected **Stewart Engineering Inc.** The recommendation to Council is to approve the selection by the Mayor, and to award **RFQ PS012-21 Professional Consulting Services for System Study for Electric Dept to Stewart Engineering, Inc.** and allow the Mayor to negotiate a fee for contract.

Please place on the next available City Council Agenda this request for City Council to approve the selection by the Mayor for RFQ PS012-21 Professional Consulting Services for System Study for Electric Dept and authorize the Mayor to negotiate the fee to be approved by Council.

161 North Section Street
PO Drawer 429
Fairhope, Alabama 36533

Cc: file; Jeremy Morgan, S Sullivan

251-928-2136

251-928-6776 Fax
www.fairhopeal.gov



MEMO

To: **Kim Crech, Treasurer**
From: *Delores A Brandt*
Delores A Brandt, Purchasing Manager

Sherry Sullivan
Mayor

Date: **May 11, 2021**

Re: Mayor to choose consultant for **RFQ PS012-21 Professional Consulting Services for System Study** for Electric Dept

The Electric Department Assistant Superintendent, Jeremy Morgan, and the Superintendent of Utilities, Mayor Sherry Sullivan, request the hiring of a professional consulting firm for **RFQ No. PS012-21 Professional Consulting Services for System Study** for the Electric Department for the Electric Dept. Per our Procedure for Procuring Professional Services the Assistant Superintendent, and I are routing this short list through you, to the Mayor. Please move this procurement of professional services forward to the Mayor for selection of a professional service provider.

The purpose for hiring the company is to perform professional consulting services to determine overall load and conductor sizes for the electric system.

The short list is:

- ds* 5, 11, 21 Stewart Engineering Inc
Anniston, AL
- _____ / / _____ Kimley Horn
Mobile, AL
- _____ / / _____ Hi Line Engineering a GDS Company
Marietta GA
- _____ / / _____ None. Submit another list

Council Members:
Kevin G. Boone
Jack Burrell, ACMO
Jimmy Conyers
Corey Martin
Jay Robinson

Lisa A. Hanks, MMC
City Clerk

Kimberly Creech
Treasurer

161 North Section St.
PO Box 429
Fairhope, AL 36533

Cc: file, Jeremy Morgan, Mayor Sherry Sullivan

251-928-2136 (p)

PURCHASING DEPARTMENT REQUEST FORM

Requestor: Jeremy Morgan Department: Electric

Project Name: System Study

Brief Project Description: To determine the proper loading and conductor sizes for the electric system

Project Category: Item Bid Professional Service Other

Budget Amount: \$100,000.00 Budget Code: 50290

BID USE ONLY

Anticipated Start Date: _____ Project Duration: _____

Bid Duration: _____ Engineer of Record: _____

Pre-Bid Meeting: No Yes Date: _____ Mandatory Non-Mandatory

Scope of Work Provided By: _____ Contract Extensions: No Yes

Project Administered: Internally Externally By: _____

Bidders List Review: No Yes By: _____

Tax Exempt Project: No Yes Insurance Requirements: Minimum Maximum

Bonds: Bid Performance Labor & Materials Contract: Standard Construction Service

Related Bids/RFs: _____ Bid Opening: _____

FORCE ACCOUNT INFORMATION ONLY

Force Account Project: No Yes Estimated Amount: _____ Budget Code: _____

Notes: _____

SIGNATURES

Requestor: 

Finance Manager:

City Treasurer: Kim Creech
Kim Creech (Apr 23, 2021 09:44 CDT)

Mayor: Sherry Sullivan
Sherry Sullivan (Apr 23, 2021 15:59 CDT)

RESOLUTION NO. _____

BE IT RESOLVED BY THE GOVERNING BODY OF THE CITY OF FAIRHOPE, ALABAMA, as follows:

[1] That the City of Fairhope did request, receive, and open quotes for N. Beach Pavilion Repair and Replacement of Asphalt Shingle Roof – FEMA 4563 that was damaged by Hurricane Sally for the Public Works Department at 555 South Section Street in the City of Fairhope offices, Fairhope, Alabama (RFQ 013-21).

[2] RFQ No. 013-21 was sent to 7 contractors, and viewed by 65 of 299 e-notifications, as well as multiple State agencies for MBE and DEB consideration, advertised in newspaper and in the Public Utilities Building. The City did not receive any quotes.

[3] After evaluating the quotes with the required bid specifications, only one responsive quote was received. Therefore, the recommendation is to reject the one quote due to excessive price; and authorize staff to seek informal quotes.

Adopted on this 14th day of June, 2021

Jack Burrell, Council President

Attest:

Lisa A. Hanks, MMC
City Clerk



MEMO

2021
ZAH

To: Kimberly Creech, Treasurer

From: Delores A Brandt
Delores A. Brandt, Purchasing Manager

Sherry Sullivan
Mayor

Date: May 26, 2021

Council Members:
Kevin G. Boone
Robert A. Brown
Jack Burrell, ACOM
Jimmy Conyers
Corey Martin

Re: **Greensheet/City Council agenda to approve the award of RFQ 013-21 N. Beach Pavilion Repair and Replacement of Asphalt Shingle Roof—FEMA 4563 that was damaged by Hurricane Sally (FEMA 4563)**

Lisa A. Hanks, MMC
City Clerk

The roof of the pavilion at North beach was damaged during Hurricane Sally and the Public Works Director, Richard Johnson, has requested quotes it its repair. The damage that occurred was on or about September 15, 2020 when Hurricane Sally (FEMA4563) hit the Alabama coast and Mobile Bay.

Kimberly Creech
City Treasurer

A request for quotes for the roof repair at the pavilion was emailed to 7 contractors, posted to the website for the City of Fairhope, and viewed by 65 of 299 e-notifications, as well as multiple state agencies for MBE and DBE consideration, advertised in newspaper and in the Public Utilities Building lobby. The RFQ which opened on May 26, received one responsive bid response.

The Director of Public Works recommends rejection of the one bid due to excessive Price, and seek informal quotes.

Please place on the next City Council Agenda this request to reject all bids for RFQ 013-21 N. Beach Pavilion Repair and Replacement of Asphalt Shingle Roof—FEMA 4563

Cc: File, R. Johnson, G. Ladd

161. North Section St.
PO Drawer 429
Fairhope, AL 36533

251-928-2136 (p)
251-928-6776 (f)
www.fairhopeal.gov

CITY OF FAIRHOPE BID TABULATION & RECOMMENDATION

RFQ 013-21 North Beach Pavilion Repair and Replace Asphalt Shingle Roof--FEMA 4563

RFQ OPENED: May 25, 2021 1:00 a.m.

Vendor	RFQ Docs Signed/ Notarized	Quote Response Form	Contractor Information	Anti-Lobbying Certification	Additional Documentation Required	New Asphalt Roof repair and Replace	Alternate--26 gauge classic rib metal--galvalume or equivalent
Summers Roofing & Construction Co., Inc	yes	yes	yes	yes	#21887	\$15,006.00	\$20,364.00

Recommendation: Reject the one bid response.

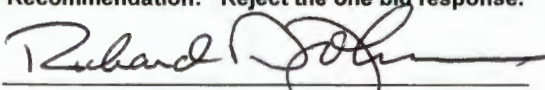
 Richard D Johnson, Public Works Director

5/26/2021
 Date

 Delores A. Brandt, Purchasing Manager

 Date

RESOLUTION NO. _____

BE IT RESOLVED BY THE GOVERNING BODY OF THE CITY OF FAIRHOPE, ALABAMA, that Mayor Sherry Sullivan is hereby authorized to execute a contract with Vision Technology Solutions, LLC d/b/a Vision Internet Providers to perform Professional Services for Website Design and Management (RFQ No. PS017-21) with a not-to-exceed amount of \$11,205.81.

DULY ADOPTED THIS 14TH DAY OF JUNE, 2021

Jack Burrell, Council President

Attest:

Lisa A. Hanks, MMC
City Clerk

City of Fairhope
Project Funding Request

Issuing Date: 6/4/2021

Please return this Routing Sheet to Treasurer by: ASAP

Project Name: Professional Services for Website Design and Management RFQ No. PS017-21

JUN 7 '21 09:47

YAN

Project Location: City

Presented to City Council: 6/14/2021

Funding Request Sponsor: Jeff Montgomery, Director of Information Technology

Resolution # :
Approved _____
Changed _____
Rejected _____

Project Cash Requirement Requested:
Cost: \$ 11,205.61 Not-to-Exceed

Vendor: Vision Technology Solutions, LLC dba Vision Internet Providers

Project Engineer: n/a

Order Date: n/a

Lead Time: n/a

Department Funding This Project

General Gas Electric Water Sewer Gas Tax Cap Project Impact Health Fed Grant

Department of General Fund Providing the Funding

Admin-10 Bldg-13 Police-15 Fire-20 ECD-24 Rec-25 Civic-26 Street-35 Sanitation-40
Fac Maint-45 Golf-50 Golf Grounds-55 Museum-70 Debt Service-85 Marina-34 Plan/Zone

Project will be:

Expensed XXX
Capitalized _____
Inventoried _____

Funding Source:

Operating Expenses XXX
Budgeted Capital _____
Unfunded _____

Expense Code: xxx-50300
G/L Acct Name: Computer

Grant: \$0.00 Federal - not to exceed amount
State _____
City _____
Local _____

Project Budgeted: \$ 10,000.00
Balance Sheet Item-
Included in projected
cash flow

Over (Under) budget amount: \$ 1,205.61

Bond: _____ Title _____ Year _____
Loan: _____ Title _____ Year _____

Comments:

Capital Lease: _____ - Payment _____ Term _____

City Council Prior Approval/Date? _____

Senior Accountant

City Treasurer

Mayor

Purchasing Memo Date: 6/3/2021

Purchasing Memo Date: 6/3/2021

Delivered To Date: 6/4/2021

Request Approved Date: 6/4/2021

Request Approved Date: 6/4/2021

Approved Date: _____

Signatures: Aislinn Stone
Aislinn Stone

Kim Creech
Kim Creech

Mayor Sherry Sullivan
Mayor Sherry Sullivan



Date: June 3, 2021

To: Aislinn Stone, Senior Accountant
Kim Creech, Treasurer

From: Delores A Brandt
Delores A Brandt, Purchasing Manager

Sherry Sullivan
Mayor

Re: **Selection of provider for RFQ PS017-21 Professional Services for Website Design and Management 2021**

Council Members:

Kevin G. Boone
Jack Burrell, ACOMO
Jimmy Conyers
Corey Martin
Jay Robinson

Lisa A. Hanks, MMC
City Clerk

Kimberly Creech
City Treasurer

The City of Fairhope needs to hire a professional consulting firm for **RFQ PS017-21 Professional Services for Website Design and Management 2021**. This item is budgeted for FY2021 and is a necessary part of the communications for the City. Per our Procedure for procuring Professional Services, the Mayor chose, **Vision Technology Solutions, LLC dba VISION INTERNET PROVIDERS**, of El Segundo, CA. to provide these services. The City has contacted this company for the past three years and the contract has expired. The purpose for hiring the Consultant is to provide website development, VisionLIVE subscription services, and/or other extra work and services as required by the City's IT Department for the next year.

Please move this procurement of professional Services forward to the City Council for approval of the Mayor to negotiate a fee with a Not-To-Exceed amount of **ELEVEN THOUSAND TWO HUNDRED Five DOLLARS and EIGHTY-ONE cents (\$11,205.81)** and authorize the Mayor to sign the Contract for the Professional Services.

Please place on the next available City Council Agenda this request for City Council to approve the selection of Vision Technology Solutions, LLC dba VISION INTERNET PROVIDERS for RFQ No. PS017-21, Professional Services for Website Design and Management, with a not- to-exceed amount of \$11,205.81 and authorize the Mayor to sign the contract

161 North Section Street
PO Drawer 429
Fairhope, Alabama 36533

CC: file, Jeff Montgomery,

251-928-2136

251-928-6776 Fax
www.fairhopeal.gov

RESOLUTION NO. 4045-21

BE IT RESOLVED BY THE GOVERNING BODY OF THE CITY OF FAIRHOPE, ALABAMA, That the City Council approves the selection of Vision Technology Solutions, LLC d/b/a Vision Internet Providers to perform Professional Services for Website Design and Management RFQ No. PS017-21; and hereby authorizes Mayor Sherry Sullivan to negotiate a fee schedule and establish a not-to-exceed limit with this firm.

DULY ADOPTED THIS 12TH DAY OF APRIL, 2021

Jack Burrell, Council President

Attest:

Lisa A. Hanks, MMC
City Clerk



MEMO

To: Lisa Hanks, City Clerk
Kim Creech, Treasurer

Sherry Sullivan
Mayor

From: *Delores A Brandt*
Delores A Brandt, Purchasing Manager

Council Members:
Kevin G. Boone
Robert A. Brown
Jack Burrell, ACMO
Jimmy Conyers
Corey Martin

Date: March 11, 2021

Re: Selection of professional consultant for RFQ PS017-21 Professional Services for Website Design and Management 2021

Lisa A. Hanks, MMC
City Clerk

The IT Director, Jeff Montgomery, is requesting the hiring of a professional consulting firm for **RFQ No. PS017-21 Professional Consulting Services for Website Design and Management 2021**. Per our Procedure for Procuring Professional Services, Jeff Montgomery and I are providing this list of firms from which the Mayor may select to receive the RFQ. Please move this procurement of professional services forward to the Mayor for selection of a professional service provider.

Kimberly Creech
Treasurer

The purpose for hiring the company is to perform website design services and management for the City of Fairhope.

The short list is:

js 3, 15, 21

Vision Technology Solutions, LLC dba VISION INTERNET PROVIDERS

 / /

None. Submit another list

61 North Section St.
PO Box 429
Fairhope, AL 36533

Cc: file, Jeff Montgomery

251-928-2136 (p)

CITY OF FAIRHOPE PURCHASING DEPARTMENT REQUEST FORM

Name: Jeff Montgomery

Date: 3/10/2021

Department: IT

ITEM OR SERVICE INFORMATION

1. What item or service do you need to purchase? Website Renewal
2. What is the total cost of the item or service? 11205.81
3. Where will the item or service be physically located? Granicus cloud
4. What is the primary function of the item or service? City Website
5. How many do you need? N/A
6. Item or Service Is: New Used Replacement Annual Request
7. When do you anticipate implementation? Continued subscription
8. Additional Information or Comments: Yearly renewal for website hosting services for City Website. Term 3/15/21 to 3/14/22

BUDGET INFORMATION

1. Is it budgeted? Yes No Emergency Request
2. If budgeted, what is the budgeted amount? \$10,000
3. What is the Capital Project Name or Operating Budget Code: All - 50380
4. Check any applicable boxes: State Contract ALDOT Purchasing Group
 Sole Source (Attach Sole Source Justification)

Email completed form with quotes or other supporting documentation to deedee.brandt@fairhopeal.gov and jennifer.bush@fairhopeal.gov.

PURCHASING USE ONLY

Vendor Name: Granicus (Vision Internet) Vendor Number: 5294

Current Business License: Yes No. **Does not come on site.

RESOLUTION NO. _____

BE IT RESOLVED BY THE GOVERNING BODY OF THE CITY OF FAIRHOPE, ALABAMA, that Mayor Sherry Sullivan is hereby authorized to execute a contract with S.E. Civil, LLC to perform Professional Engineering Services for Water Main Replacement at SR 181 along ROW to CR 34 for the Water Department (RFQ No. PS024-21) with a not-to-exceed amount of \$23,500.00.

DULY ADOPTED THIS 14TH DAY OF JUNE, 2021

Jack Burrell, Council President

Attest:

Lisa A. Hanks, MMC
City Clerk

City of Fairhope
Project Funding Request

Issuing Date: 6/4/2021

Please return this Routing Sheet to Treasurer by: ASAP

Project Name: Approval of negotiated Not-to-Exceed amount on RFQ PS024-21 Professional Engineering Services for Water Main Replacement on SR181 JUN 7 2021 4:43 PM

Project Location: SR181 along ROW to CR34

Presented to City Council: 6/14/2021

Funding Request Sponsor: Sherry Sullivan, Mayor
Jason Langley, Water & Sewer Superintendent

Resolution # :
Approved _____
Changed _____
Rejected _____

Project Cash Requirement Requested:
Cost: \$ 23,500.00 Not-to-Exceed

Vendor: S.E. Civil Engineering and Surveying

Project Engineer: n/a

Order Date: n/a Lead Time: n/a

Department Funding This Project

General Gas Electric **Water** Sewer Gas Tax Cap Project Impact Health Fed Grant

Department of General Fund Providing the Funding

Admin-10 Bldg-13 Police-15 Fire-20 ECD-24 Rec-25 Civic-26 Street-35 Sanitation-40
Fac Maint-45 Golf-50 Golf Grounds-55 Museum-70 Debt Service-85 Marina-34 Plan/Zone

Project will be:

Expensed
Capitalized XXX
Inventoried

Pending Source:

Operating Expenses
Budgeted Capital XXX
Unfunded

Expense Code: 004010-59500
G/L Acct Name: System Improve-Distribution System

Grant: \$0.00 Federal - not to exceed amount
State _____
City _____
Local \$0.00

Project Budgeted: \$ 23,500.00
Balance Sheet Item- Included in projected cash flow

Over (Under) budget amount: \$ -

Comments:

The new engineering services are budgeted for FY2021 with a projected cost of \$300,000 through the multi-year \$900,000 Water Systems Improvements for the city.

Bond: _____ Title _____ Year _____
Loan: _____ Title _____ Year _____

Capital Lease: _____ - Payment _____ Term _____

City Council Prior Approval/Date? _____

Senior Accountant Aislinn Stone **City Treasurer** Kim Creech **Mayor** Sherry Sullivan

Purchasing Memo Date: 5/25/2021 Purchasing Memo Date: 5/25/2021 Delivered To Date: 6/4/2021

Request Approved Date: 6/4/2021 Request Approved Date: 6/4/2021 Approved Date: _____

Signatures: Aislinn Stone Kim Creech Sherry Sullivan



MEMO

To: Kimberly Creech, Treasurer
From: Delores A Brandt
Delores A Brandt, Purchasing Manager

Sherry Sullivan
Mayor

Date: May 25, 2021

Re: Approval of negotiated not-to-exceed fees for budgeted professional services for
**RFQ PS024-21 Professional Engineering Services for Water Main
Replacement on SR181 along ROW to CR34**

Council Members
Kevin G. Boone
Jack Burrell, ACO
Jimmy Conyers
Corey Martin
Jay Robinson

The new engineering services are budgeted for FY2021 with a projected cost of \$300,000 through the multi-year \$900,000 Water Systems Improvements for the City.

Lisa A. Hanks, MMC
City Clerk

The City Council approved the Mayor's selection of **S. E. Civil Engineering and Surveying**, at the May 24, 2021 City Council meeting, and authorized the Mayor to set a Not-To-Exceed amount for the work. Due to considerable number of breaks in this section of the water main the work of engineering will be based upon the surveying of approximately 2300 LF of SR181 and designing a new water line to replace the existing 6" PVC Class 160 pipe with 8" DIP. The professional services provided will be for the five proposed tasks:

Kimberly Creech
City Treasurer

TASK I Boundary survey and Topographic Survey
TASK II Utility Plan
TASK III ALDOT Permit
TASK IV CBMPP and ADEM NPDES PERMIT
TASK V Bidding and Procurement (assist the City)

The negotiated Not-to-Exceed fee is **TWENTY-THREE THOUSAND FIVE HUNDRED DOLLARS (\$23,500.00)** for **RFQ PS024-21 Professional Engineering Services for Water Main Replacement on SR181 along ROW to CR34**

Please place on the Council Agenda this request for approval of negotiated not-to-exceed amount of \$23,500.00 and allow the Mayor to sign the contract.

161 North Section Street
PO Drawer 429
Fairhope, Alabama 36533

Cc: file; S Sullivan, Jason Langley

251-928-2136

251-928-6776 Fax
www.fairhopeal.gov



April 13, 2021

Jason Langley
City of Fairhope
555 S Section Street
Fairhope, AL 36532
Jason.langley@fairhopeal.gov

**RE: Civil Engineering Proposal – SR 181 Water Line Upgrade
Fairhope, Alabama**

Dear Jason:

We are pleased to submit this engineering service proposal for the Site Work Improvement Plans for the above referenced project. The site is located on SR 181 between the entrance to Stone Creek and CR 34. The proposal is based upon surveying approximately 2300 LF of SR 181 and designing a new water line to replace the existing 6" CL 160 Pipe with an 8" DIP. We reserve the right to review and revise this proposal based on any changes to the scope of this project.

Please note that the Alabama Administrative Code Section 330-X-14-.05(f) does not allow Engineers or Land Surveyors to participate in "bidding" for services. Examples include but are not limited to, simultaneous negotiations or solicitation of fee proposals by the client from two or more engineers or land surveyors constitutes "bidding" and participation by a licensee is prohibited. If this proposal is part of "bidding" process, I withdrawal my proposal. I also would ask that you notify the other engineer(s). If you have any questions about this rule, I would be glad to speak with you or direct you to our licensing board.

Thank you again for the opportunity to provide you with this proposal. If you find these services in order, please execute by signing, dating, initialing and returning one (1) copy to us for our files.

If you have any questions, please do not hesitate to contact me.

Sincerely,

A handwritten signature in black ink, appearing to read 'Larry Smith', written in a cursive style.

Larry Smith, PE
Partner



**S.E. Civil, LLC
Professional Services Agreement**

Part 1 General:

This Agreement, including attachments as hereinafter noted, made and entered into and between S.E. Civil, LLC and the Client identified herein, provides for the Professional Services described under Part 3 of this Agreement.

Client: City of Fairhope

Address: 555 S. Section St

City, State, Zip Code: Fairhope, AL 36532

Contact Person: Jason Langley

Phone Number: 251-

Email: jason.langley@fairhopeal.gov

Accounts Payable Email: jason.langley@fairhopeal.gov

Short Title: SR 181 Water Line Upgrade, or the "Project"

Part 2 General Description of the Project Site:

The site is located on SR 181 between the entrance to Stone Creek and CR 34.

Part 3 Description of Professional Services to be provided by S.E. Civil LLC:

Task I - Boundary Survey and Topographic Survey

Scope: Perform a boundary and topographic survey of the right of way. Locate utilities in the right of way. Utility depths for utilities in the vicinity of the water line will be recorded via ground penetrating radar.

Task II – Utility Plan

Scope: Submit the plans to the city for review and approval.

Task III - ALDOT Permit

Scope: Create an ALDOT connection plan and submit to ALDOT for review and approval.

Task IV- CBMPP and ADEM NPDES Permit Application (NOI)

Scope: Create a CBMPP and fill out the ADEM NOI application and submit it to ADEM for review and approval.

Task V – Bidding and Procurement

Scope: Create a unit price estimate for the work. Assist the city with bidding out the work. Attend pre-bid meeting. Prepare a certified bid tab and assist the city with contracts.

Exclusions to this scope of work shall be as follows:

1. Phase I or Phase II Environmental Studies.
2. Wetlands Determination or Delineation.
3. Off-Site Utility Improvements, including upgrades of existing facilities or line extensions to the site. Furthermore, this proposal does not include design of an onsite sewage pump station or an onsite water booster station.
4. Federal Emergency Management Agency (Flood) studies or USACE permitting
5. Site Lighting Plans
6. Application and preparation of plans which do not meet the requirements of the local/state/governing authorities.
7. Retaining wall design is not included. Profiles and size requirements shall be provided, if required.
8. Volume capacity calculations of downstream stormwater drainage facilities.
9. Traffic Concurrency, Traffic Studies, signal designs, or warrant analyses.
10. Septic Tank Design & Permitting.
11. Landscape and/or Irrigation Design.
12. Subdivision of the land for lots or right of way dedication.
13. Construction staking.
14. Construction Engineering and Inspection (CE&I)

Part 4 The Compensation to be Paid to S.E. Civil, LLC for providing the requested Services shall be as follows:

Proposed Fee for Task I	\$6,100.00
Proposed Fee for Task II	\$11,500.00
Proposed Fee for Task III	\$1,750.00
Proposed Fee for Task IV	\$1,750.00
Proposed Fee for Task V	\$2,400.00

<u>Staff Member</u>	<u>Hourly Rate</u>
Engineer:	\$125.00
Surveyor:	\$125.00
Survey Crew	\$150.00
Engineer in Training:	\$95.00
Inspector	\$80.00
Administrative	\$50.00

GENERAL TERMS AND CONDITIONS

Date of Commencement and Duration: The Date of Commencement of this Agreement shall be the date appearing on the signature page. This agreement shall remain in effect for 12 months from the acceptance date of this agreement, or until terminated as provided herein. If the Professional Services Agreement is not executed within ninety (90) days, we reserve the right to modify the scope, schedule, or fee based on current conditions.

Reimbursable Costs: Reimbursable costs include but are not limited to, reproduction costs, courier service, overnight deliveries, mileage, and telephone/fax. Reimbursable costs will be charged at actual cost plus five percent (5%). Professional Subcontractors (whose expertise is required to complete the project) will be charged at actual costs plus an administrative charge of ten percent (10%) and shall be itemized and included in the invoice.

Invoice Procedures and Payment: S.E. Civil, LLC will prepare invoices on a monthly basis. For Services provided on a Lump Sum basis, the amount of each monthly invoice shall be determined on the "percentage of completion method" whereby S.E. Civil, LLC will estimate the percentage of the total Services accomplished during the invoicing period. Monthly invoices shall include, separately listed, any charges for service for which time charges and/or unit costs apply. Such invoices shall also include, separately listed, any charges for Professional Subcontractors and reimbursable costs. S.E. Civil, LLC shall submit such invoices as soon as possible after the end of the month in which Services were accomplished and shall be due and payable by the Client upon receipt.

The Client, as owner or authorized agent for the owner, hereby agrees that payment will be made for said services within thirty (30) days from the date of the invoice; and, in default of such payment, hereby agrees to pay all costs of collection, including reasonable attorney's fees, regardless of whether legal action is initiated. The client hereby acknowledges that unpaid invoices shall accrue interest at eighteen percent (18%) per annum after they have been outstanding for over thirty (30) days. If an invoice remains unpaid sixty (60) days after the date of the invoice, S.E. Civil, LLC may, upon giving seven (7) days written notice of its intent to do so, suspend all Services on the Client's project. This suspension shall remain in effect until all unpaid invoices are paid in full. If an invoice remains unpaid ninety (90) days after the date of the invoice, S.E. Civil, LLC may, upon giving seven (7) days written notice of its intent to do so, terminate this Agreement and pursue its remedies for collection.

Cost Estimates: Client hereby acknowledges that S.E. Civil, LLC cannot warrant that estimates of probable construction or operating costs will not vary from actual costs incurred by the Client.

Limit of Liability: The limit of liability of S.E. Civil, LLC to the Client for any cause or combination of causes resulting from the Services hereunder rendered, shall be, in total amount, limited to the fees paid under this agreement.

Construction Administration: If, under this agreement, professional services are provided during the construction phase of the project, S.E. Civil, LLC shall not be responsible for or have control over means, methods, techniques, sequences, or procedures; or for safety precautions and programs in connection with the Work. Nor shall S.E. Civil, LLC be responsible for the Contractor's failure to carry out the Work in accordance with the Contract Documents or for Contractor's failure to comply with applicable laws, ordinances, rules or regulations. Under no circumstances will S.E. Civil, LLC have any direct contractual relationship with the contractor, any subcontractors or material suppliers.

Assignment: Neither the Client nor S.E. Civil, LLC will assign or transfer its interest in this Agreement without the written consent of the other. S.E. Civil, LLC, however, does reserve the right to subcontract any portion of the Services.

Suspension, Termination, Cancellation, or Abandonment: In the event the Project described in, or the Services of S.E. Civil, LLC called for under this Agreement, is/are suspended, canceled, terminated, or abandoned by the Client, S.E. Civil, LLC shall be given seven (7) days prior written notice of such action and shall be compensated for Services provided up to the date of suspension, termination, cancellation, or abandonment including reimbursable expenses in accordance with the provisions of this Agreement.

Entirety of Agreement: This Agreement embodies the entire Agreement and understanding between the parties, their successors and assigns hereto, and there are no other agreements and understandings, oral or written, with reference to the subject matter hereof that are not merged herein and superseded hereby. No alternation, change, or modification of the terms of this Agreement shall be valid unless made in writing and signed by both parties hereto. The laws of the State of Alabama shall govern this Agreement unless specifically stated otherwise. This Agreement includes this document.

Hold Harmless: The Client will hold harmless and indemnify S.E. Civil, LLC, its officers, directors, partners, employees, agents and consultants from and against, any costs, losses and damages (including but not limited to reasonable fees and charges of engineers, architects, attorneys, and other professionals and reasonable court or arbitration or other dispute resolution costs) caused solely or in part by the clients' negligent acts or omissions or anyone employed by the client with respect to the work referenced in this agreement.

In Witness Whereof, this Agreement, which is subject to the General Terms and Conditions is accepted on the later date written below.

City of Fairhope

S.E. Civil, LLC

Signed: _____

Signed: _____

Typed Name: _____

Typed Name: Larry Smith, PE

Title: _____

Title: Partner

Date: _____

Date: 4/13/2021

SR 181 WATER LINE REPLACEMENT
 PRE-DESIGN ENG. ESTIMATE
 PROJECT NO. XXXXXX

ITEM	DESCRIPTION	UNIT	QTY.	UNIT PRICE	AMOUNT
GRADING & DRAINAGE					
100.00	MOBILIZATION	LS	1	\$ 15,000.00	\$ 15,000.00
101.00	CONSTRUCTION ENTRANCE	LS	1	\$ 5,000.00	\$ 5,000.00
102.00	CLEARING AND GRUBBING (GRASSED)	ACRE	1	\$ 3,000.00	\$ 3,000.00
103.00	SEEDING, FERTILIZING, & MULCHING (ALL DISTURBED AREAS)	ACRE	1	\$ 2,500.00	\$ 2,500.00
104.00	STRAW WATTLES	LF	500	\$ 5.00	\$ 2,500.00
105.00	SILT FENCE (INSTALLATION & REMOVAL)	LF	1000	\$ 5.00	\$ 5,000.00
106.00	8" DUCTILE IRON WATER MAIN	LF	2300	\$ 60.00	\$ 138,000.00
107.00	8" M.J. 22.5 DEGREE BEND	EA	8	\$ 520.00	\$ 4,160.00
108.00	8" M.J. GATE VALVES	EA	2	\$ 1,800.00	\$ 3,600.00
109.00	DIRECTIONAL DRILL W/16" HDPE ENCASEMENT	LF	180	\$ 150.00	\$ 27,000.00
110.00	CONNECTION TO EXISTING WATER MAIN	EA	2	\$ 1,500.00	\$ 3,000.00
111.00	WATER SERVICE	EA	15	\$ 1,000.00	\$ 15,000.00
112.00	FIRE HYDRANT ASSEMBLY (INCLUDES TEE, VALVE & HYDRANT)	EA	6	\$ 4,250.00	\$ 25,500.00
113.00	REMOVAL OF EXISTING 6" MAIN	LF	2300	\$ 8.00	\$ 18,400.00
114.00	ASPHALT PAVEMENT PATCH	SY	28	\$ 9.00	\$ 252.00
115.00	GRAVEL PAVEMENT PATCH	SY	36	\$ 4.00	\$ 144.00
116.00	8" AIR RELEASE VALVE	LF	1	\$ 2,500.00	\$ 2,500.00
	TOTAL FOR WATER				\$ 237,556.00
	**ALL TESTING OF THE WATER MAINS & APPURTENANCES SHALL BE A SUBSIDIARY OBLIGATION OF THE INSTALLATION OF SUCH.				
MISCELLANEOUS					
200.00	ENGINEERING CONTROLS	LS	1	\$ 5,000.00	\$ 5,000.00
201.00	MAINTENANCE BOND	LS	1	\$ 10,000.00	\$ 10,000.00
202.00	20% CONTINGENCY	LS	1	\$ 47,511.20	\$ 47,511.20
	TOTAL FOR MISCELLANEOUS				\$ 62,511.20
CONSTRUCTION GRAND TOTAL					\$ 300,067.20

RESOLUTION NO. _____

BE IT RESOLVED BY THE GOVERNING BODY OF THE CITY OF FAIRHOPE, ALABAMA, as follows:

[1] That the City of Fairhope did request, receive, and open bids for Materials for Masonry and Concrete Work for ADA Compliance Project at Fairhope Municipal Stadium for the Recreation Department (Bid No. 028-21).

[2] At the appointed time and place, the following bids were opened and tabulated as follows:

Please see attached Bid Tabulations for
Materials for Masonry and Concrete Work
ADA Compliance Project at Fairhope Municipal Stadium

[3] After evaluating the bid proposals with the required bid specifications, Bay Steel Corporation with a total bid proposal of \$22,274.00, is now awarded the bid for Masonry and Concrete Work for ADA Compliance Project at Fairhope Municipal Stadium for the Recreation Department.

Adopted on this 14th day of June, 2021

Jack Burrell, Council President

Attest:

Lisa A. Hanks, MMC
City Clerk

City of Fairhope
Project Funding Request

Issuing Date: 6/4/2021

Please return this Routing Sheet to Treasurer by: ASAP

Project Name: Award Bid No. 028-21 Materials for Masonry and concrete Work for ADA Compliance Project

JUN 7 '21 AM 9:48

JAN

Project Location: Stadium

Presented to City Council: 6/14/2021

Resolution # :
Approved _____

Funding Request Sponsor: Richard Johnson, Public Works Director
George Ladd, Supervisor Streets and Facilities Maintenance
Pat White, Recreation Director

Changed _____

Rejected _____

Project Cash Requirement Requested:
Cost: \$ 22,274.00

\$ _____

Vendor: Bay Steel Corp.

Project Engineer: n/a

Order Date: n/a

Lead Time: n/a

Department Funding This Project

General Gas Electric Water Sewer Gas Tax **Cap Project** Impact Health Fed Grant

Department of General Fund Providing the Funding

Admin-10 Bldg-13 Police-15 Fire-20 ECD-24 Rec-25 Civic-26 Street-35 Sanitation-40
Fac Maint-45 Golf-50 Golf Grounds-55 Museum-70 Debt Service-85 Marine-34 Plan/Zone

Project will be:

Expensed _____
Capitalized XXX
Inventoried _____

Funding Source:

Operating Expenses _____
Budgeted Capital _____
Unfunded _____

Expense Code: 103-55883
G/L Acct Name: ADA Platforms and Ramps

Grant: \$0.00 Federal - not to exceed amount
State _____
City _____
Local _____

Project Budgeted: \$ 22,274.00
Balance Sheet Item-
Included in projected cash flow

Over (Under) budget amount: \$ _____

Bond: _____ Title _____ Year _____
Loan: _____ Title _____ Year _____

Comments:

Capital Lease: _____ - Payment _____ Term _____

City Council Prior Approval/Date? _____

Senior Accountant

City Treasurer

Mayor

Purchasing Memo Date: 6/4/2021

Purchasing Memo Date: 6/4/2021

Delivered To Date: 6/4/2021

Request Approved Date: 6/4/2021

Request Approved Date: 6/4/2021

Approved Date: _____

Signatures: *Aislinn Stone*
Aislinn Stone

Signatures: *Kim Creech*
Kim Creech

Signatures: *Sherry Sullivan*
Mayor Sherry Sullivan



MEMO

Sherry Sullivan
Mayor

To: Aislinn Stone, Senior Accountant
Kimberly Creech, City Treasurer
From: Delores A Brandt
Delores A. Brandt, Purchasing Manager

Council Members:
Kevin G. Boone
Robert A. Brown
Jack Burrell, ACOMO
Jimmy Conyers
Corey Martin

Date: June 4, 2021

Lisa A. Hanks, MMC
City Clerk

Re: **Greensheet/City Council agenda to approve the award of BID 028-21 Materials Bid for Masonry and Concrete Work for ADA Compliance Project**

The City has need to make changes and improvements to the Stadium including upgrading the ADA features as required. Due to the unstable pricing of items for construction of any kind, a materials bid was put forth.

Kimberly Creech
City Treasurer

A materials bid was issued on May 20, 2021 was emailed to several suppliers, posted to the Website for the City of Fairhope and viewed by 73 of 302 e-notifications, and advertised in the Mobile Press and in the Public Utilities Building lobby. The BID which opened on June 3, 2021, received one response for the Steel items. There was no bid submitted for the brick/ masonry items.

The Director of Public Works recommends the award be made to Bay Steel Corporation of Mobile, AL in the amount of **TWENTY—TWO THOUSAND TWO HUNDRED SEVENTY-FOUR DOLLARS (\$22,274.00)** for their bid for the steel items as requested.

Please prepare a greensheet and place on the next City Council Agenda this request to award BID 028-21 Materials Bid for Masonry and Concrete Work for ADA Compliance Project to Bay Steel Corp. in the amount of \$22,274.00.

Cc: File, R. Johnson, G. Ladd, Pat White

161 North Section St.
PO Drawer 429
Fairhope, AL 36533

251-928-2136 (p)
251-928-6776 (f)
www.fairhopeal.gov

CITY OF FAIRHOPE BID TABULATION

BID 028-21 Materials Bid for Masonry and Concrete Work for ADA Compliance Project

BID OPENED: June 3, 2021, 10:00 a.m.

7 emailed, minority, women-owned, special interest, and SBDC sites, viewed by 63 of 294 notifications

Vendor	Bid Docs Signed/Notarized	Contractor License	Adendum # 1 and #2	Qty	DESCRIPTION	EXTRA INFO	PRICE PER UNIT	DELIVERY ARO	TOTALS
Bay Steel Corporation	Yes	Yes	Yes	260'	# 3 rebar		\$ 0.40	4 Days	\$104.00
				170pcs	#4 rebar "L" Shaped stirups 48" long--		\$6.80	4 Days	\$1,156.00
				30	8x8x16 concrete block corners		N/A	N/A	N/A
				30	8x8x8 half block corners		N/A	N/A	N/A
				400' or 40pcs	Dura-wall ladder style block reinforcement wire 10' lengths		N/A	N/A	N/A
				8 cu Yds	Masonry Sand		N/A	N/A	N/A
				13,000	Menowa Queen-size Brick		N/A	N/A	N/A
				100 bags	buff mortar mix		N/A	N/A	N/A
				16 CU YDS	whitewashed mortar sand for brick	Need white because of buff mortar-Baldwin Sand & Gravel mines it	N/A	N/A	N/A
				17 PCS	Galvanized 6x4x3/8" angle-A36/A529G50—20 ft long each	Needed before pouring concrete	\$370.00	4 Days	\$6,290.00
				One drum	Concrete Cure & Seal	one drum or enough covering 3500sq ft. of concrete slab.	N/A	N/A	N/A
				400 cu yds	Sandy/Clay fill material		N/A	N/A	N/A
				135 PIECES	20" LENGTH 1 1/2" SCH 40 ALUMINUM ROUND PIPE		\$88.00	4 Days	\$11,880.00
				8 pieces	1 1/2" SCH 40 alum pipe cap		\$109.00	1 Week	\$872.00
				34 pieces	1 1/2" SCH40 alum pipe 90° elbow		\$58.00	1 Week	\$1,972.00
TOTAL									\$22,274.00

Recommendation: Award to Bay Steel Corporation for those items bid.

For  6-4-21
 Richard D. Johnson, Director, Public Works Date

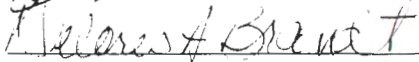
 6-11-21
 Delores A. Brandt, Purchasing Manager Date

RESOLUTION NO. _____

BE IT RESOLVED BY THE GOVERNING BODY OF THE CITY OF FAIRHOPE, ALABAMA, as follows:

[1] That the City of Fairhope did request, receive, and open bids for New Scoreboard-Video Message Board for Fairhope Municipal Stadium for the Recreation Department (Bid No. 026-21).

[2] At the appointed time and place, the following bids were opened and tabulated as follows:

Please see attached Bid Tabulations for
New Scoreboard-Video Message Board
at Fairhope Municipal Stadium

[3] After evaluating the bid proposals with the required bid specifications, Electro-Mech with a total bid proposal of \$226,940.00, is now awarded the bid for New Scoreboard-Video Message Board for Fairhope Municipal Stadium for the Recreation Department. The Fairhope High School has committed \$176,000.00 to be paid over a five-year period in participation with the City of Fairhope.

Adopted on this 14th day of June, 2021

Jack Burrell, Council President

Attest:

Lisa A. Hanks, MMC
City Clerk

City of Fairhope
Project Funding Request

Issuing Date: 6/4/2021

Please return this Routing Sheet to Treasurer by: ASAP

Project Name: Award Bid No. 026-21 Procurement of New Scoreboard-Video Message Board for City Stadium

Project Location: Fairhope Municipal Stadium

JUN 7 '21 AM 8:48

Presented to City Council: 6/14/2021

Resolution # :
Approved _____

Funding Request Sponsor: Pat White, Recreation Director
George Ladd, Supervisor Streets and Facilities Maintenance

Changed _____

Rejected _____

Project Cash Requirement Requested:
Cost: \$ 226,940.00

Vendor: ELECTRO MECH

Project Engineer: n/a

Order Date: n/a

Lead Time: n/a

Department Funding This Project

General Gas Electric Water Sewer Gas Tax Cap Project Impact Health Fed Grant

Department of General Fund Providing the Funding

Admin-10 Bldg-13 Police-15 Fire-20 ECD-24 **Rec-26** Civic-26 Street-35 Sanitation-40
Fac Maint-45 Golf-50 Golf Grounds-55 Museum-70 Debt Service-85 Marina-34 Plan/Zone

Project will be:

Funding Source:

Expensed _____
Capitalized XXX
Inventoried _____

Operating Expenses _____
Budgeted Capital _____
Unfunded _____

Expense Code: 001250-50475
G/L Acct Name: Capital Improvements

Grant: \$0.00 Federal - not to exceed amount
State _____
City _____
\$176,000.00 Local (Paid By Fairhope High School)

Project Budgeted: \$ _____
Balance Sheet Item-
Included in projected
cash flow

Over (Under) budget amount: \$ 226,940.00

Bond: _____ Title _____ Year _____
Loan: _____ Title _____ Year _____

Comments:

Fairhope High School will commit to pay \$176,000 to be paid over a five-year period.

Capital Lease: _____ - Payment _____ Term _____

City Council Prior Approval/Date? _____

Senior Accountant

City Treasurer

Mayor

Purchasing Memo Date: 6/1/2021

Purchasing Memo Date: 6/1/2021

Delivered To Date: 6/4/2021

Request Approved Date: 6/4/2021

Request Approved Date: 6/4/2021

Approved Date: _____

Signatures: Aislinn Stone
Aislinn Stone

Hjm Creech
Hjm Creech

Mayor Sherry Sullivan
Mayor Sherry Sullivan



MEMO

Sherry Sullivan
Mayor

Council Members:
Kevin G. Boone
Jack Burrell, ACMO
Jimmy Conyers
Corey Martin
Jay Robinson
Lisa A. Hanks, MMC
City Clerk

Kimberly Creech
Treasurer

To: Kimberly Creech, Treasurer

From: Delores A Brandt
Delores A Brandt, Purchasing Manager

Date: June 1, 2021

Re: **Requesting greensheet and approval by Council to award unbudgeted Bid 026-21 New Scoreboard—Video Message Board for City Stadium**

The Parks and Recreations Director, Pat White, is requesting the procurement of a new scoreboard and video board for the City's stadium, to be funded through various sports groups, as well as the City.

This is an unbudgeted item that will be an asset to the City for community and sports events. **Bid 026-21 New Scoreboard—Video Message Board for City Stadium** was properly advertised and sent to numerous companies that sell and erect message/scoreboards and was posted on the website for the City of Fairhope. We received three responsive bids. **The Lowest was the responsive bid was from ELECTRO MECH for TWO HUNDRED TWENTY-NINE THOUSAND NINE HUNDRED FORTY DOLLARS (\$226,940.00).**

Please place on the next City Council Agenda this request to award Bid No. 026-21 New Scoreboard—Video Message Board for City Stadium, to ELECTRO MECH in Wrightsville, GA 31096

CC: file, Pat White, George Ladd, Clint Steadham, Randy Weaver,

161 North Section St.
PO Drawer 429
Fairhope, AL 36533

251-928-2136 (p)
251-928-6776 (f)
www.fairhopeal.gov

CITY OF FAIRHOPE PURCHASING DEPARTMENT REQUEST FORM

Name: Pat White

Date: 6/1/2021

Department: Parks and Recreation

ITEM OR SERVICE INFORMATION

- 1. What item or service do you need to purchase?** Scoreboard / Video Message Board for Municipal Stadium
- 2. What is the total cost of the item or service?** \$226,940.00
- 3. Where will the item or service be physically located?** Fairhope Municipal Stadium
- 4. What is the primary function of the item or service?** Scorekeeping / Video for football games and other events
- 5. How many do you need?** 1
- 6. Item or Service Is:** New Used Replacement Annual Request
- 7. When do you anticipate implementation?** ASAP
- 8. Additional Information or Comments:** Funding from multiple sources i.e. FHS, COF, private donors
- 9. Vendor Name:** Electromech
- 10. Vendor Number:** Click or tap here to enter text.

BUDGET INFORMATION

- 1. Is it budgeted?** Yes No Emergency Request
- 2. If budgeted, what is the budgeted amount?** \$0
- 3. What is the Capital Project Name or Operating Budget Code:** Click or tap here to enter text.
- 4. Check any applicable boxes:** State Contract ALDOT Purchasing Group
 Sole Source (Attach Sole Source Justification)

*Email completed form with quotes and other supporting documentation to
deedee.brandt@fairhopeal.gov and jennifer.bush@fairhopeal.gov.*



PRINCIPAL
JON CARDWELL

FAIRHOPE HIGH SCHOOL

ONE PIRATE DRIVE
FAIRHOPE, ALABAMA 36532

TELEPHONE (251) 928-8309
FAX (251) 990-2053

June 4, 2021

Dear City of Fairhope Parks and Recreation:

Fairhope High School will commit \$176,000 to be paid over a five-year period in participation with the city of Fairhope.

The installments will be paid from Fairhope High School on August 3rd of each year (or the business day following that date if on a non-business day). Each payment will be \$35,000 per year, with the exception of one year payment totaling \$36,000.

This letter will serve as our commitment to honoring this purchase.

As always, we appreciate our partnership with the City of Fairhope.

Sincerely,

Jon Cardwell
Principal

RESOLUTION NO. _____

BE IT RESOLVED BY THE GOVERNING BODY OF THE CITY OF FAIRHOPE, ALABAMA, as follows:

[1] That the City of Fairhope did request, receive, and open bids for Nix Center Repair/Replace Asphalt Roof Shingles – FEMA 4563 for Community Affairs Department (Bid No. 022-21).

[2] At the appointed time and place, the following bids were opened and tabulated as follows:

Please see attached Bid Tabulations for
Nix Center Repair/Replace Asphalt Roof Shingles
for Community Affairs Department

[3] After evaluating the bid proposals with the required bid specifications, VON Electric General Contractors, LLC with a total bid proposal of \$120,000.00, is now awarded the bid for Nix Center Repair/Replace Asphalt Roof Shingles – FEMA 4563 for Community Affairs Department.

Adopted on this 14th day of June, 2021

Jack Burrell, Council President

Attest:

Lisa A. Hanks, MMC
City Clerk

City of Fairhope
Project Funding Request

Issuing Date: 6/4/2021

Please return this Routing Sheet to Treasurer by: ASAP

Project Name: Award Bid No. 022-21 Nix Center Repair/Replace Asphalt Roof Shingles

JUN 7 '21 AM 8:48
[Signature]

Project Location: Nix Center

Presented to City Council: 6/14/2021

Funding Request Sponsor: Richard Johnson, Public Works Director
George Ladd, Supervisor Streets and Facilities Maintenance

Resolution # :
Approved _____
Changed _____
Rejected _____

Project Cash Requirement Requested:
Cost: \$ 120,000.00

Vendor: VON Electric General Contractors, LLC

Project Engineer: n/a

Order Date: n/a Lead Time: n/a

Department Funding This Project

General Gas Electric Water Sewer Gas Tax Cap Project Impact Health Fed Grant

Department of General Fund Providing the Funding

Admin-10 Bldg-13 Police-15 Fire-20 ECD-24 Rec-25 Civic-26 Street-35 Sanitation-40
 Fac Maint-45 Golf-50 Golf Grounds-55 Museum-70 Debt Service-85 Marina-34 Plan/Zone

Project will be: Expensed _____
 Capitalized XXX
 Inventoried _____

Funding Source: Operating Expenses _____
 Budgeted Capital _____
 Unfunded _____

Expense Code: 001300-50475
 G/L Acct Name: Capital Improvements

Grant: \$0.00 Federal - not to exceed amount
 _____ State
 _____ City
\$0.00 Local

Project Budgeted: \$ _____
 Balance Sheet Item Included in projected cash flow

Over (Under) budget amount: \$ 120,000.00 Insurance Claim Filed

Bond: _____ Title _____ Year _____
 Loan: _____ Title _____ Year _____

Capital Lease: _____ - Payment _____ Term _____

Comments: Repairs due to damages that occurred during Hurricane Sally (FEMA 4563).

City Council Prior Approval/Date? _____

Senior Accountant City Treasurer Mayor

Purchasing Memo Date: 5/26/2021 Purchasing Memo Date: 5/26/2021 Delivered To Date: 6/4/2021

Request Approved Date: 6/4/2021 Request Approved Date: 6/4/2021 Approved Date: _____

Signatures: Aislinn Stone Kim Creech Mayor Sherry Sullivan



MEMO

To: Kimberly Creech, Treasurer

From: Delores A Brandt
Delores A. Brandt, Purchasing Manager

Date: May 26, 2021

Sherry Sullivan
Mayor

Council Members:

Kevin G. Boone
Robert A. Brown
Jack Burrell, ACMO
Jimmy Conyers
Corey Martin

Lisa A. Hanks, MMC
City Clerk

Kimberly Creech
City Treasurer

Re: Greensheet/City Council agenda to approve the award of BID 022-21 Nix Center Repair and Replace Asphalt Roof Shingles—FEMA 4563 that was damaged by Hurricane Sally (FEMA 4563)

The roof of the JP Nix Center was damaged during Hurricane Sally and the Public Works Director, Richard Johnson, has requested bids for its repair. The damage that occurred was on or about September 15, 2020 when Hurricane Sally (FEMA4563) hit the Alabama coast and Mobile Bay.

A bid was issued on May 5, 2021 for the roof repair and was emailed to 7 contractors, posted to the website for the City of Fairhope, as well as multiple state agencies for MBE and DBE consideration, advertised in the Mobile Press and in the Public Utilities Building lobby. The BID which opened on May 26, 2021, received three responses.

The Director of Public Works recommends the award be made to the lowest bid from **VON Electric General Contractors, LLC**. in the amount of **ONE HUNDRED TWENTY THOUSAND DOLLARS (\$120,000.00)**.

Please prepare a greensheet and place on the next City Council Agenda this request to award BID 022-21 Nix Center Repair and Replace Asphalt Roof Shingles—FEMA 4563, damage that occurred during Hurricane Sally (FEMA 4563) to VON Electric General Contractors, LLC. in the amount of \$120,000.00.

Cc: File, R. Johnson, G. Ladd

161 North Section St.
PO Drawer 429
Fairhope, AL 36533

251-928-2136 (p)
251-928-6776 (f)
www.fairhopeal.gov

CITY OF FAIRHOPE BID TABULATION

BID 022-21 Nix Ctr Repair and Replace Asphalt Roof Shingles--FEMA 4563

BID OPENED: May 26, 2021, 10:00 a.m.

7 emailed, minority, women-owned, special interest, and SBDC sites, viewed by 68 of 300 enotifications

Vendor	Bid Docs Signed/Notarized	Response Form	Contractor Information/li cense	addenda 1 & 2	Anti-Lobbying Certification	Additional Documentation Required	Lump Sum Price
Summers Roofing & Construction Co. Inc	yes	yes	21887	1 and 2	not signed	yes	\$151,566.00
Thomas Industries Inc dba Thomas Roofing	yes	yes	12847	2	not signed	yes	\$253,694.00
VON Electric General Contractors. LLC	yes	yes	50147	2	not signed	yes	\$120,000.00

Recommendation: Award bid to VON Electric General Contractors, LLC for \$120,000.00

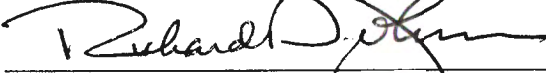

Richard Johnson, Public Works Director

5/26/2021
Date



Delores A. Brandt, Purchasing Manager

5-26-21
Date

RESOLUTION NO. _____

BE IT RESOLVED BY THE GOVERNING BODY OF THE CITY OF FAIRHOPE, ALABAMA, as follows:

[1] That the City of Fairhope did request, receive, and open bids for City-Wide Concrete Work, Curbing, ADA Ramps, Inlets, and Structures for the Public Works Department and Utilities (Bid No. 018-21).

[2] At the appointed time and place, the following bids were opened and tabulated as follows:

Please see attached Bid Tabulations for
City-Wide Concrete Work, Curbing, ADA Ramps, Inlets,
and Structures for the Public Works Department and Utilities

[3] After evaluating the bid proposals with the required bid specifications, Parten Smith, Inc. with a bid proposal for the unit amounts shown in the attached bid tabulation, is now awarded the bid for City-Wide Concrete Work, Curbing, ADA Ramps, Inlets, and Structures for the Public Works Department and Utilities.

Adopted on this 14th day of June, 2021

Jack Burrell, Council President

Attest:

Lisa A. Hanks, MMC
City Clerk

City of Fairhope
Project Funding Request

Issuing Date: 6/4/2021

Please return this Routing Sheet to Treasurer by: ASAP

Project Name: Award Bld No. 018-21 City Wide Concrete Work, Curbing, ADA Ramps, Inlets and Structures to Parten Smith Inc

Project Location: City Wide

Presented to City Council: 6/14/2021

Funding Request Sponsor: Richard Johnson, Public Works Director
George Ladd, Supervisor Streets and Facilities Maintenance
Terry Holman, Gas Superintendent
Jason Langley, Water & Sewer Superintendent

Resolution #: JUN 7 '21 AM 8:48
Approved _____
Changed _____
Rejected _____

[Handwritten Signature]

Project Cash Requirement Requested:
Cost: \$ _____ - As Needed/See Attached

Vendor: Parten Smith Inc

Project Engineer: n/a

Order Date: n/a Lead Time: n/a

Department Funding This Project

General Gas Electric Water Sewer Gas Tax Cap Project Impact Health Fed Grant

Department of General Fund Providing the Funding

Admin-10 Bldg-13 Police-15 Fire-20 ECD-24 Rec-25 Civic-26 **Street-35** Sanitation-40
Fac Maint-45 Golf-50 Golf Grounds-55 Museum-70 Debt Service-85 Marine-34 Plan/Zone

Project will be:

Expensed XXX
Capitalized _____
Inventoried _____

Funding Source:

Operating Expenses XXX
Budgeted Capital _____
Unfunded _____

Expense Code: xxx-50360
G/L Acct Name: General Maintenance

Grant: \$0.00 Federal - not to exceed amount
State _____
City _____
\$0.00 Local

Project Budgeted: \$ _____
Balance Sheet Item-
Included in projected
cash flow

Over (Under) budget amount: \$ _____

Bond: _____ Title _____ Year _____
Loan: _____ Title _____ Year _____

Comments: Pricing will be for one year, with possible two one-year extensions if both parties agree.

Capital Lease: _____ - Payment _____ Term _____

City Council Prior Approval/Date? _____

Senior Accountant

City Treasurer

Mayor

Purchasing Memo Date: 5/28/2021

Purchasing Memo Date: 5/28/2021

Delivered To Date: 6/4/2021

Request Approved Date: 6/4/2021

Request Approved Date: 6/4/2021

Approved Date: _____

Signatures: Aislinn Stone
Aislinn Stone

Kim Creech
Kim Creech

Sherry Sullivan
Mayor Sherry Sullivan



MEMO

Sherry Sullivan
Mayor

To: Kimberly Creech, Treasurer
From: Delores A Brandt
Delores A Brandt, Purchasing Manager

Date: May 28, 2021

Council Members
Kevin G. Boone
Jay Robinson
Jack Burrell, ACOMO
Jimmy Conyers
Corey Martin

Re: Requesting Greensheet and City Council approval to award **Bid No. 018-21 City-wide Concrete Work, Curbing, ADA Ramps, Inlets & Structures**

Lisa A. Hanks, MMC
City Clerk

The Director of Public Works, Richard Johnson, and the Utilities have requested various types of smaller concrete work to be bid on an annual basis.

Bid No. 018-21 City-wide Concrete Work for Sidewalks, Curbing, ADA Ramps, Inlets, & Structures was issued on April 29 2021 to multiple vendors and opened on May 26, 2021, 1:00 PM. 8 of 306 vendors viewed the bid, and the City received 1 response. The bid was properly advertised, emailed and listed on the City's website. The pricing will be for one year, with possible two one-year extensions if both parties agree.

Kimberly Creech
City Treasurer

A Tabulation and Recommendation was composed (see attached). The Director of Public Works recommends award be made to **Parten Smith Inc** of St. Elmo, AL, the lowest responsive and responsible bidder, for the amounts listed on the bid tabulation attached.

Please construct a greensheet and place on the next City Council Agenda this request to award Bid No. 018-21 City-wide Concrete Work, Curbing, ADA Ramps, Inlets & Structures to Parten Smith Inc, for as needed work for the Public Works and Utilities Departments in the amounts listed on the bid tabulation.

Cc: file; Richard Johnson, George Ladd; Jason Langley, Terry Holman, Clint Steadham

61 North Section Street PO
Drawer 429
Fairhope, Alabama 36533

251-928-2136

251-928-6776 Fax
www.fairhopeal.gov

PROJECT REQUEST FORM

Project Owner: Richard D. Johnson, PE Department: Public Works
Bid Number and Name: Bid 018-21 City-Wide Concrete Work
Budget Amount: N/A Budget Code: N/A
Anticipated Start Date: On Call Bid for Services Project Duration: 1 yr plus options for extensions
Bid Duration: 1 yr plus options for extensions Engineer of Record: N/A

Pre-Bid Meeting: No Yes Date: Purchasing to Set Mandatory Non-Mandatory

Scope of Work Provided By: Richard Johnson Contract Extensions: No Yes

Project Administered: Internally Externally By: Requesting Departments

Bidders List Review: No Yes By: _____

Tax Exempt Project: No Yes Insurance Requirements: Minimum Maximum

Bonds: Bid Performance Labor & Materials Contract: Standard Construction Professional

Related Bids/RFs: N/A Bid Opening: _____

Force Account Project: No Yes Estimated Amount: N/A Budget Code: N/A

Notes: Work will be requested by various departments as needed.

SIGNATURES

Requestor: Richard D. Johnson, PE
Digitally signed by Richard D. Johnson, PE
Date: 2021.04.29 09:42:53 -05'00'

Finance Manager:

City Treasurer: Kim Creech
Kim Creech (Apr 29, 2021 10:19 CDT)

Mayor: Sherry Sullivan
Sherry Sullivan (Apr 29, 2021 13:58 CDT)

CITY OF FAIRHOPE TAB

BID NO: 018-21

BID NAME: City Wide Concrete Work Sidewalks, Curbing, ADA Ramps, Inlets and Structures

BID OPENED: Wednesday, May 26, 2021 10:00 a.m.

6 emailed, viewed by 86 of 305 notifications

All Bid Unit Prices shall include mobilization, labor, materials, and equipment used to complete the task	PARTEN SMITH INC		
Bid Response Executed/ Signed/ Notarized	yes		
Vendor Compliance Yes or No	yes		
Contractor License #	53550		
Insurance Proof			
Addenda 1,2,3	yes		
Concrete Sidewalk 4" Thick (Portland Cement 4000 psi) sq yd	\$70.00		
Concrete Sidewalk 6" Thick (Portland Cement 4000 psi) sq yd	\$90.00		
Concrete Sidewalk 4" Thick Reinforced with Wire Mesh (Portland Cement 4000 psi) sq yd	\$75.00		
Concrete Sidewalk 6" Thick Reinforced with Wire Mesh (Portland Cement 4000 psi) sq yd	\$95.00		
Steel Reinforcement (USA Steel) LBS	\$1.5 0		
Minor Structure Concrete (Portland Cement 4000 psi) CU Yd	\$1,500.00		
Truncated dome retrofit Sq Ft	\$400.00		
ADA Ramp Replacement, Retrofit and New Construction (4000 psi) sq ft	\$150.00		
Inlet Top/Lid Replacement (Portland Cement 4000 psi) sq ft	\$250.00		
Curb, Gutter and Combination Curb & Gutter Replacement (4000 psi) LF	\$40.00		
Mobilization Fee (for Project subsets less than 5CY of concrete placed)	\$3,500.00		

Recommendation: Award to Parten Smith, Inc. in the amounts quoted in his bid and listed above

To the best of my knowledge this is an accurate Bid Tabulation

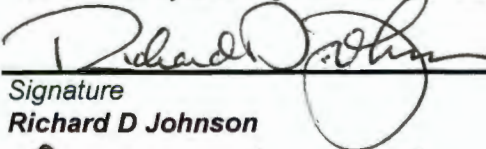
 5/26/2021
 Signature Date
Richard D Johnson

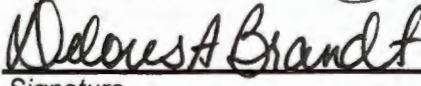
 5/26/21
 Signature Date
Delores A Brandt, Purchasing Manager

RESOLUTION NO. _____

BE IT RESOLVED BY THE GOVERNING BODY OF THE CITY OF FAIRHOPE, ALABAMA, as follows:

[1] That the City of Fairhope did request, receive, and open bids for Six (6) Overhead Doors for Fire Station #3 (Bid Number 014-21).

[2] At the appointed time and place, the following bids were opened and tabulated as follows:

Please see attached Bid Tabulation for
Six Overhead Doors for Fire Station #3

[3] After evaluating the bid proposals with the required bid specifications, Bailey Door, Inc., with a total bid proposal of \$40,038.00, is now awarded the bid for Six Overhead Doors for Fire Station #3.

Adopted on this 14th day of June, 2021

Jack Burrell, Council President

Attest:

Lisa A. Hanks, MMC
City Clerk

City of Fairhope
Project Funding Request

Issuing Date: 6/4/2021

Please return this Routing Sheet to Treasurer by: ASAP

Project Name: Award Bid No. 014-21 Six (6) Overhead Doors for Fire Station 3 to Bailey Door Inc.

JUN 7 '21 4:48

7/11

Project Location: Fire Station 3

Presented to City Council: 6/14/2021

Funding Request Sponsor: John Saraceno
Richard Johnson, Public Works Director

Resolution # :
Approved _____
Changed _____
Rejected _____

Project Cash Requirement Requested:
Cost: \$ 40,038.00

Vendor: Bailey Door Inc.

Project Engineer: n/a

Order Date: n/a Lead Time: n/a

Department Funding This Project

General Gas Electric Water Sewer Gas Tax Cap Project Impact Health Fed Grant

Department of General Fund Providing the Funding

Admin-10 Bldg-13 Police-15 **Fire-20** ECD-24 Rec-25 Civic-26 Street-35 Sanitation-40
Fac Maint-45 Golf-50 Golf Grounds-55 Museum-70 Debt Service-85 Marine-34 Plan/Zone

Project will be:

Expensed _____
Capitalized XXX
Inventoried _____

Funding Source:

Operating Expenses _____
Budgeted Capital XXX
Unfunded _____

Expense Code: 001200-50475
G/L Acct Name: Capital Improvements

Grant: \$0.00 Federal - not to exceed amount
State _____
City _____
\$0.00 Local

Project Budgeted: \$ 42,642.00
Balance Sheet Item-
Included in projected
cash flow

Over (Under) budget amount: \$ (2,604.00)

Bond: _____ Title _____ Year _____
Loan: _____ Title _____ Year _____

Comments:

Capital Lease: _____ - Payment _____ Term _____

City Council Prior Approval/Date? _____

Senior Accountant

City Treasurer

Mayor

Purchasing Memo Date: 5/20/2021

Purchasing Memo Date: 5/20/2021

Delivered To Date: 6/4/2021

Request Approved Date: 6/4/2021

Request Approved Date: 6/4/2021

Approved Date: _____

Signatures: Aislinn Stone
Aislinn Stone

Kim Creech
Kim Creech

Mayor Sherry Sullivan
Mayor Sherry Sullivan



MEMO

Sherry Sullivan
Mayor

To: **Kimberly Creech, City Treasurer**

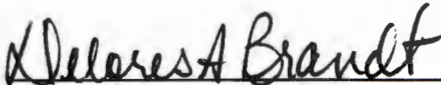
From: 
Delores A Brandt, Purchasing Manager

Council Members
Kevin G. Boone
Jack Burrell, ACOMO
Jimmy Conyers
Corey Martin
Jay Robinson

Date: **MAY 20, 2021**

Re: **Greensheet and City Council approval for budgeted procurement for Bid No. 014-21 Six (6) Overhead Doors for Fire Station #3**

Lisa A. Hanks, MMC
City Clerk

The Fire Department needs to purchase six (6) overhead doors. **Bid No. 014-21 Six (6) Overhead Doors for Fire Station 3 (at the Airport)** was issued on April 23, 2021. Responses were received and publicly opened on May 17, 2021.

Kimberly Creech
City Treasurer

The Bid was properly advertised, posted to the City's website, and sent to numerous vendors. Two responsive and one non-responsive bids were received. The recommendation by the Fire Department is to award to **Bailey Door, Inc.**, as the lowest responsive bidder with a bid of **FORTY THOUSAND THIRTY-EIGHT DOLLARS (\$40,038.00)** for the 6 doors.

The line item 50475 of FY 2021 was budgeted in the amount is \$42,642.00

Please prepare a greensheet and place on the next available City Council agenda this recommendation to award Bid No. 014-21 Six (6) Overhead Doors for Fire Station #3 to Bailey Door, Inc. in the quoted amount of \$40,038.00

Cc: file; J. Saraceno, Richard Johnson, Clint Steadham, Randy Weaver

161 North Section Street
PO Drawer 429
Fairhope, Alabama 36533

251-928-2136

251-928-6776 Fax
www.fairhopeal.gov

CITY OF FAIRHOPE Tab and Recommendation
Bid 014-21 Doors for Fire Station 3
BID OPENED: May 17, 2021 - 9:00 a.m.

Vendor	Addenda #1	Bid Documents Signed / Notarized (Y/N)	Lead Time for Delivery (in days)	Lead Time for Installation (in days)	Per Door Price Including Installation	Total for Six (6) Doors	Vendor Compliance (Y/N)
BAILEY DOOR, INC	YES	YES	56-63	8-10 days	\$6,673.00	\$40,038.00	YES
PORT CITY INDUSTRIAL (not licensed at time of bid submittal)						non responsive	
TRANSLIFT DOCK & DOOR, LLC	NO	YES	10 WEEKS (50 DAYS)	1-2 WKS (5-10 DAYS)	\$7,313.00	\$43,878.00	

Recommendation: Bailey Door, Inc

To the best of my knowledge this is an accurate Bid Tabulation

Signature

John Saraceno
John Saraceno, Fire Maintenance Supervisor

Signature

Delores A Brandt
Delores A Brandt, Purchasing Manager

5/20/2021
 Date

5/20/2021
 Date

RESOLUTION NO. _____

BE IT RESOLVED BY THE GOVERNING BODY OF THE CITY OF FAIRHOPE, ALABAMA, as follows:

[1] That the City of Fairhope did request and solicit quotes for Reshape/Rebuild Greens on Holes #6 and #11 of Quail Creek Golf Course.

[2] After evaluating the Quotes with the required specifications, Sur-Line Turf, Inc. is now awarded the procurement to Reshape/Rebuild Greens on Holes #6 and #11 of Quail Creek Golf Course with a total approximate cost of \$21,080.00.

Adopted on this 14th day of June, 2021

Jack Burrell, Council President

Attest:

Lisa A. Hanks, MMC
City Clerk

City of Fairhope
Project Funding Request

Issuing Date: 6/4/2021

Please return this Routing Sheet to Treasurer by: ASAP

Project Name: Award reshape/rebuild greens on holes #6 and #11 of Quail Creek to Sur-Line Turf Inc.

JUN 9 '21 PM 4:09

Project Location: Quail Creek Golf Club

Presented to City Council: 6/14/2021

Resolution # :
Approved _____

Funding Request Sponsor: Bobby Hall, Quail Creek Golf Pro
Jeff Williams, Golf Grounds Supervisor

Changed _____

Rejected _____

Project Cash Requirement Requested:
Cost: \$ 21,080.00

Vendor: Sur-Line Turf Inc.

Project Engineer: n/a

Order Date: n/a Lead Time: n/a

Department Funding This Project

General Gas Electric Water Sewer Gas Tax Cap Project Impact Health Fed Grant

Department of General Fund Providing the Funding

Admin-10 Bldg-13 Police-15 Fire-20 ECD-24 Rec-25 Civic-26 Street-35 Sanitation-40
Fac Maint-45 Golf-50 **Golf Grounds-55** Museum-70 Debt Service-85 Marina-34 Plan/Zone

Project will be:

Expensed _____
Capitalized XXX
Inventoried _____

Funding Source:

Operating Expenses _____
Budgeted Capital XXX
Unfunded _____

Expense Code: 001550-50475
G/L Acct Name: Capital Improvements

Grant: \$0.00 Federal - not to exceed amount
State _____
City _____
\$0.00 Local

Project Budgeted: \$ 25,000.00
Balance Sheet Item-
Included in projected
cash flow

Over (Under) budget amount: \$ (3,920.00)

Bond: _____ Title _____ Year _____
Loan: _____ Title _____ Year _____

Comments: _____

Capital Lease: _____ - Payment _____ Term _____

City Council Prior Approval/Date? _____

Senior Accountant

City Treasurer

Mayor

Purchasing Memo Date: 5/20/2021

Purchasing Memo Date: 5/20/2021

Delivered To Date: 6/4/2021

Request Approved Date: 6/4/2021

Request Approved Date: 6/4/2021

Approved Date: _____

Signatures: Austin Stone
Austin Stone

Kim Creech
Kim Creech

Mayor Sherry Sullivan
Mayor Sherry Sullivan



Sherry Sullivan
Mayor

Council Members:
Kevin G. Boone
Jack Burrell, ACMO
Jimmy Conyers
Corey Martin
Jay Robinson

Lisa A. Hanks, MMC
City Clerk

Kimberly Creech
City Treasurer

MEMO

To: Kimberly Creech, Treasurer

From: Delores A. Brandt
Delores A. Brandt, Purchasing Manager

Date: May 20, 2021

Re: Greensheet/City Council agenda to approve the over \$15,000 Public Works project to rebuild greens on holes # 6 and #9 of Quail Creek Golf Club

The Director of Golf, Bobby Hall, is requesting approval to resurface two greens—one at Hole # 6 and one at Hole #9. This is a specialized public works project requiring a vendor that is trained in the construction of Golf Greens and greens maintenance.

This Public Works project was estimated at under \$50,000, and Three + Quotes were solicited. TWO quotes were 'no quotes', and ONE was a responsive Quote for approximately Nineteen Thousand Eighty dollars(\$19,080.00).

The Director of Golf recommends the award be made to **SUR-LINE TURF, Inc.** for \$1.59 per square ft for the approximate 12,000 square feet of resurfacing in the estimated amount of approximately TWENTY THOUSAND DOLLARS (\$20,000.00).

Please prepare a greensheet and place on the next City Council Agenda this request to approve and award the rebuilding of Hole #6 and Hole #9 in the estimated amount of \$20,000.00.

Cc: File, Bobby Hall, Jeff Williams

161 North Section St.
PO Drawer 429
Fairhope, AL 36533

251-928-2136 (p)
251-928-6776 (f)
www.fairhopeal.gov

CITY OF FAIRHOPE PURCHASING DEPARTMENT REQUEST FORM

Name: Jeff Williams

Date: 4/28/2021

Department: Golf Maintenance

ITEM OR SERVICE INFORMATION

1. What item or service do you need to purchase? Reshape/rebuild 6 and 11 green
2. What is the total cost of the item or service? \$20,000
3. Where will the item or service be physically located? Golf Maintenance
4. What is the primary function of the item or service? Labor / Equipment transportation
5. How many do you need? 1
6. Item or Service Is: New Used Replacement Annual Request
7. When do you anticipate implementation? ASAP
8. Additional Information or Comments: Click or tap here to enter text.
9. Vendor Name: Sur-Line Turf Inc.
10. Vendor Number: Click or tap here to enter text.

BUDGET INFORMATION

1. Is it budgeted? Yes No Emergency Request
2. If budgeted, what is the budgeted amount? \$25,000
3. What is the Capital Project Name or Operating Budget Code: Click or tap here to enter text.
4. Check any applicable boxes: State Contract ALDOT Purchasing Group
 Sole Source (Attach Sole Source Justification)

*Email completed form with quotes and other supporting documentation to
deedee.brandt@fairhopeal.gov*



19637 Gorgas Road
Northport, Alabama 35475
1.800.362.1976
205.333.1776
FAX 205.333.8388

To: Jeff Williams / Quail Creek Golf Course
From: Raymond Heath / Sur-Line Turf, Inc.
Date: May 14, 2021

RE: Resurfacing Greens

Sur-Line Turf offers the following for resurfacing two greens at Quail Creek Golf Course:

Resurfacing of 2 Greens: (Approximately 12,000 Square Feet)

*Green surfaces sprayed with Glyphosate and Fusillade by owner prior to project start up.

1. Remove approximately 2 inches of existing turf from approximately 12,000 sq. ft. of green surfaces with sod cutter and dispose of on site.
2. Float green surfaces to soften contours as needed and to improve surface drainage.
3. Spread 2 inches of clean sand on green surfaces. (Approximately 108 tons)
4. Rotovate to incorporate sand into green profiles approximately 6 inches deep.
5. Laser grid green surfaces to maximize pinnable area and ensure positive surface drainage.
6. Float green surfaces to prep for planting.
7. Plant green surfaces with Tifdwarf bermuda grass sprigs at a rate of 30 bushels per 1,000 square feet.

Sur-Line Turf can complete the above for \$1.59 per square foot, plus \$2,000.00 mobilization. All the above prices are plus any applicable taxes. Unit prices prevail.

Thank you for allowing us to provide this proposal. If you have questions or need additional information, call us at 205-333-1776.

Sincerely,

A handwritten signature in black ink, appearing to read "R. Heath", is written over the name "Raymond Heath".

Raymond Heath

From: Shur-Line Turf Inc. Offer / Quote for greens
Raymond Heath
205-333-1776

To: Jeff Williams

Re-surfacing two greens at Quail Creek Golf Course

12,000 sq feet	X \$1.59	\$19,080.00
Mobilization Fee		\$2,000.00
Total Quote:		\$21,080.00

Bobby Hall
5/16/2021

Dee Dee Brandt

From: Jeff Williams
Sent: Thursday, May 20, 2021 11:02 AM
To: Dee Dee Brandt; Bobby Hall; Pat White
Subject: FW: from Scott Veazey

Information for 6 and 11 green rebuild

From: sveazey@surfsouth.com <sveazey@surfsouth.com>
Sent: Thursday, May 20, 2021 11:00 AM
To: Jeff Williams <Jeff.Williams@fairhopeal.gov>
Subject: from Scott Veazey

SENT FROM AN EXTERNAL ADDRESS

Good morning Jeff,

Southeastern appreciates the opportunity for the project, but at this time we're not able to bid due to a scheduling conflict.

Again, thanks for the opportunity and please keep us in mind for any future projects.

Sincerely,

Scott Veazey
Southeastern Golf, Inc.
PO Box 7667
Tifton, GA 31793
(229) 382-7107

Dee Dee Brandt

From: Bobby Hall
Sent: Monday, May 10, 2021 3:51 PM
To: Pat White; Jeff Williams; Dee Dee Brandt
Subject: FW: Quail Creek Golf Course- Green Renovation

FYI

Sent from Mail for Windows 10

From: clay@stewartenvironmental.com
Sent: Monday, May 10, 2021 3:50 PM
To: [Bobby Hall](#)
Cc: crawfordstephen88@gmail.com
Subject: Quail Creek Golf Course- Green Renovation

SENT FROM AN EXTERNAL ADDRESS

Bobby,

Thank you for the opportunity to quote the Green Renovation on Quail Creek Golf Course- Fairhope, AL. Unfortunately, due to existing obligations with our projects and the time constraints on this project, we will not be able to quote this project.

Thank you again for giving us the opportunity to work on this project.

Please include us on future projects.

Clay Stewart, CEO
Stewart Environmental Construction Inc.
2488 Mitchell Rd.
Tupelo, MS. 38801
O. (662) 841-9202
F. (662) 841-9208
C. (662) 871-5200
clay@stewartenvironmental.com- Email

Dee Dee Brandt

From: Bobby Hall
Sent: Thursday, May 13, 2021 8:09 AM
To: Jeff Williams; Pat White
Subject: Re: Greens 6 and 11

Great, thanks for the update.

Bobby Hall

Director of Golf
PGA Class A Member
Quail Creek Golf Course
19841 Quail Creek Drive
Fairhope, AL 36532
Pro Shop: 251-990-0240
Ext #572
Email: bobby.hall@fairhopeal.gov



From: Jeff Williams <Jeff.Williams@fairhopeal.gov>
Sent: Thursday, May 13, 2021 7:54 AM
To: Bobby Hall <bobby.hall@fairhopeal.gov>; Pat White <pat.white@fairhopeal.gov>
Subject: Greens 6 and 11

Southeastern will be able to give us a quote on these greens. He is scheduled to come in on Monday. I will let you know the times as soon as I get them.

Thanks,

Jeff Williams

RESOLUTION NO. _____

BE IT RESOLVED BY THE GOVERNING BODY OF THE CITY OF FAIRHOPE, ALABAMA, as follows:

[1] That the City of Fairhope has voted to purchase a 2021 F250 Crew Cab 4x4 Pickup Truck with Utility Body for the Water Department; and the type of vehicle needed is on the Alabama State Department of Purchasing bid list and therefore does not have to be let out for bid; and

[2] The following is the Alabama State Department of Purchasing contract information:

Bid Number: T193A

2021 Ford F250 Crew Cab 4x4
with Utility Body

Cost is \$41,450.00

Adopted on this 14th day of June, 2021

Jack Burrell, Council President

Attest:

Lisa A. Hanks, MMC
City Clerk

City of Fairhope
Project Funding Request

Issuing Date: 6/4/2021

Please return this Routing Sheet to Treasurer by: ASAP

Project Name: Procurement of 2021 Ford F250 Crew Cab 4x4 Truck and Service Body JUN 7 '21 10:47 AM

Project Location: Water Dept

Presented to City Council: 6/14/2021

Funding Request Sponsor: Jason Langley, Water & Sewer Superintendent
Tim Bung, Supervisor Vehicle mechanics

Resolution # :
Approved _____
Changed _____
Rejected _____

Project Cash Requirement Requested:
Cost: \$ 41,450.00

Vendor: Stiver's Ford Lincoln

Project Engineer: n/a

Order Date: n/a Lead Time: n/a

Department Funding This Project

General Gas Electric **Water** Sewer Gas Tax Cap Project Impact Health Fed Grant

Department of General Fund Providing the Funding

Admin-10 Bldg-13 Police-15 Fire-20 ECD-24 Rec-25 Civic-26 Street-35 Sanitation-40
Fac Maint-45 Golf-50 Golf Grounds-55 Museum-70 Debt Service-85 Marina-34 Plan/Zone

Project will be: Expensed Capitalized Inventoried

Funding Source: Operating Expenses Budgeted Capital Unfunded

Expense Code: 004010-50470 Grant: \$0.00 Federal - not to exceed amount
G/L Acct Name: Capital Purchases - Vehicles & Equipment State _____
City _____
Local _____

Project Budgeted: \$ 45,750.00
Balance Sheet Item Included in projected cash flow

Over (Under) budget amount: \$ (4,300.00)

Comments:

Bond: _____ Title _____ Year _____
Loan: _____ Title _____ Year _____

Capital Lease: _____ - Payment _____ Term _____

City Council Prior Approval/Date? _____

<u>Senior Accountant</u>	<u>City Treasurer</u>	<u>Mayor</u>
Purchasing Memo Date: <u>6/3/2021</u>	Purchasing Memo Date: <u>6/3/2021</u>	Delivered To Date: <u>6/4/2021</u>
Request Approved Date: <u>6/4/2021</u>	Request Approved Date: <u>6/4/2021</u>	Approved Date: _____
Signatures: <u>Aislinn Stone</u> Aislinn Stone	<u>Kim Creech</u> Kim Creech	<u>Mayor Sherry Sullivan</u> Mayor Sherry Sullivan



MEMO

To: **Aislinn Stone, Senior Accountant**
Kimberly Creech, Treasurer

From: *Delores A Brandt*
Delores A Brandt, Purchasing Manager

Sherry Sullivan
Mayor

Date: **June 3, 2021**

Council Members:
Kevin G. Boone
Jack Burrell, ACOMO
Jimmy Conyers
Corey Martin
Jay Robinson

Re: **Greensheet --CC Approval procurement of budgeted request for ONE (1) 2021—F250 Crew Cab (Extended) 4X4 Truck and Utility Body for the Water Department**

Lisa A. Hanks, MMC
City Clerk

The Water and Sewer Department Superintendent, Jason Langley, is requesting procurement of **ONE (1) 2021 -- F250 Crew Cab 4X4 Truck and Service Body**. The Water and Sewer budgeted amount is \$85,000 for two trucks. Best pricing is from the **State of Alabama, Vehicle Contract T193-A MA999 200000000114** through **STIVER'S FORD LINCOLN** in Montgomery, AL.

The quote for ONE (1)) 2021-- F250 Crew Cab 4X4 Truck and Service body includes delivery fee of approximately \$270. The estimated cost of the truck and body plus required options is **FORTY-ONE THOUSAND FOUR HUNDRED FIFTY DOLLARS (\$41,450.00)**.

The State contract vendor is **STIVER'S FORD LINCOLN in Montgomery, AL**.

NOTES:

See Attached Vendor CUT-SHEET printout for details.
Delivery/pickup: this is in stock-- 3-4 weeks ARO

Please compose a greensheet and place on the next available City Council Agenda this request to approve budgeted procurement for one (1)) 2021-- F250 Crew Cab 4X4 Truck and Service body, from STIVER'S FORD LINCOLN in Montgomery, AL, for the Water and Sewer Dept for an estimated amount of \$41,450.00.

161 North Section
Street PO Drawer 429
Fairhope, Alabama
36533

251-928-2136

CC file, Jason Langley, Tim Bung, Clint Steadham

251-928-6776 Fax
www.fairhopeal.gov

Dee Dee Brandt

From: Jason Langley
Sent: Thursday, June 3, 2021 7:20 AM
To: Dee Dee Brandt
Cc: Sherry Sullivan; Kimberly Creech; Lisa A. Hanks, MMC
Subject: truck purchase request
Attachments: Purchasing Request Stivers.docx; Untitled.PDF

Please see attached purchase request.

Can I please get this on council agenda for the June 14th. I wouldn't ask but we are down two truck currently and I have one person working out of a car. I would not ask if it was not a true need for our department. We have been trying to find trucks for months. I can assure you this was not done at the last minute. Any help would be most appreciated.

Jason

CITY OF FAIRHOPE PURCHASING DEPARTMENT REQUEST FORM

Name: Jason S Langley

Date: 6/3/2021

Department: Water & Sewer

ITEM OR SERVICE INFORMATION

1. **What item or service do you need to purchase?** Ford F250 W/ Utility Body
2. **What is the total cost of the item or service?** \$41,450
3. **Where will the item or service be physically located?** 555 S. Section Street
4. **What is the primary function of the item or service?** Utilized to maintain the water and sewer system
5. **How many do you need?** One
6. **Item or Service Is:** New Used Replacement Annual Request
7. **When do you anticipate implementation?** Soon as possible
8. **Additional Information or Comments:** This truck is on yard at Stivers currently with body already installed. Crew is utilizing a car currently.
9. **Vendor Name:** Stivers Ford
10. **Vendor Number:** Click or tap here to enter text.

BUDGET INFORMATION

1. **Is it budgeted?** Yes No Emergency Request
2. **If budgeted, what is the budgeted amount?** \$85,500 in vehicle budget purchasing two trucks
3. **What is the Capital Project Name or Budget Code:** 004-16030
4. **Check any applicable boxes:** State Contract ALDOT Purchasing Group
 Sole Source (Attach Sole Source Justification)

Email completed form with quotes and other supporting documentation to deedee.brandt@fairhopeal.gov and jennifer.bush@fairhopeal.gov.

Craig McAdams
334-613-5000
334-613-5018 fax

STIVERS FORD LINCOLN
4000 EASTERN BLVD
MONTGOMERY, AL 36116

Effective Date: 6/2/2021
Version: 21.0

(CREW)

2021 FORD F250 REGULAR CAB 4x2 CHASSIS ONLY - FAIRHOPE WATER DEPT

CONTRACT NUMBER: MA999 20000000114 (T193A) **LINE NUMBER:** 1 **CONTRACT AMOUNT:** \$22,797

INCLUDES: 6.2L V8 385 Horsepower FFV Engine, 6 Spd Auto, 4x2, 142" Wheelbase, 56" Cab-to-Axle; 10,000 lbs. GVWR; Ford SYNC

STATE CONTRACT PRICE (T193A)		\$	22,797	X
W2B	Upgrade to 2021 Crew Cab (4x4)	\$	6,602	X
176	Super Cab Wheelbase - 176" w/ 56" Cab-to-Axle		Included	X
996	6.2L V8 385 Horsepower		Included	X
X37	3.73 Regular Axle		Std	X
66D	Pickup Box Delete - Requires 164" Wheelbase (does not include Spare Tire, Wheel & Jack)	\$	(425)	X
512	Spare Tire, Wheel and Jack	\$	295	X
63R	HD Rear Stabilizer w/ Aux Spring (recommended for Service Body applications)	\$	125	X
TD8	LT245/75Rx17E BSW AS		Std	X
872	Rear View Camera & Prep Kit (to be installed by Body Upfitter)	\$	415	X
66S	Upfitter Switches (6 Toggle Switches) - HD Alternator (Code 67D) included at NC	\$	165	X
67D	200 Amp. HD Alternator		NC	X
90L	Power Windows, Locks, Trailer Tow Mirrors and Power Tailgate Lock, Remote Keyless Entry	\$	865	X
52B	Trailer Brake Controller	\$	270	X
525	Cruise Control	\$	235	X
592	Roof Clearance Lights	\$	95	X
KEYs	Two (2) Extra Keys w/ FOBs	\$	360	X
LED	4-LED Corner Strobes	\$	649	X
SL98SW	Reading SL Service Body, Recessed Poched Bumper, T-Handles, Install Rear View Camera. Receiver Hitch w/ 4/7-way Plug	\$	8,732	X
COLOR:				
Z1	Oxford White **		NC	X
INTERIOR:				
AS	40/20/40 Vinyl Seats - Medium Earth Gray (XL)		Std	X
DELIVERY - \$1.50 PER MILE ONE-WAY		\$	270	X

Total Price (each)

\$41,450

STATE CONTRACT TERMS:

PAYMENT DUE AT TIME OF DELIVERY

SIGNATURE: (Required)

DATE: (Required)

PURCHASE ORDER NUMBER: (Required)

Quantity: (Required)

RESOLUTION NO. _____

BE IT RESOLVED BY THE GOVERNING BODY OF THE CITY OF FAIRHOPE, ALABAMA, as follows:

[1] That the City of Fairhope has voted to purchase a 2021 F250 Super Cab Extended 4x2 Pickup Truck with Service Body for the Water Department; and the type of vehicle needed is on the Alabama State Department of Purchasing bid list and therefore does not have to be let out for bid; and

[2] The following is the Alabama State Department of Purchasing contract information:

Bid Number: T193A

2021 Ford F250 Super Cab 4x2 Extended **Cost is \$38,824.00**
with Service Body

Adopted on this 14th day of June, 2021

Jack Burrell, Council President

Attest:

Lisa A. Hanks, MMC
City Clerk

City of Fairhope
Project Funding Request

Issuing Date: 6/4/2021

Please return this Routing Sheet to Treasurer by: ASAP

Project Name: Procurement of 2021 Ford F2250 Super Cab (Extended) 4x2 Truck and Service Body for Water

JUN 7 '21 AM 3:47

JAL

Project Location: Water Dept

Presented to City Council: 6/14/2021

Funding Request Sponsor: Jason Langley, Water & Sewer Superintendent
Tim Bung, Supervisor Vehicle mechanics

Resolution # :
Approved _____
Changed _____
Rejected _____

Project Cash Requirement Requested:
Cost: \$ 38,824.00

Vendor: Stiver's Ford Lincoln

Project Engineer: n/a

Order Date: n/a

Lead Time: n/a

Department Funding This Project

General Gas Electric **Water** Sewer Gas Tax Cap Project Impact Health Fed Grant

Department of General Fund Providing the Funding

Admin-10 Bldg-13 Police-15 Fire-20 ECD-24 Rec-25 Civic-26 Street-35 Sanitation-40
Fac Maint-45 Golf-50 Golf Grounds-55 Museum-70 Debt Service-85 Marina-34 Plan/Zone

Project will be:

Funding Source:

Expensed _____
Capitalized XXX
Inventoried _____

Operating Expenses _____
Budgeted Capital XXX
Unfunded _____

Expense Code: 004010-50470
G/L Acct Name: Capital Purchases Vehicles & Equipment

Grant: \$0.00 Federal - not to exceed amount
State _____
City _____
\$0.00 Local

Project Budgeted: \$ 42,750.00
Balance Sheet Item-
Included in projected
cash flow

Over (Under) budget amount: \$ (3,926.00)

Bond: _____ Title _____ Year _____
Loan: _____ Title _____ Year _____

Comments:

Replace Green Sheet #1912-Canceled due to inability to procure 2021 Dodge Ram Crew Cab and Chassis in a timely manner.

Capital Lease: _____ - Payment _____ Term _____

City Council Prior Approval/Date? _____

Senior Accountant

City Treasurer

Mayor

Purchasing Memo Date: 5/26/2021

Purchasing Memo Date: 5/26/2021

Delivered To Date: 6/4/2021

Request Approved Date: 6/4/2021

Request Approved Date: 6/4/2021

Approved Date: _____

Signatures: *Aislinn Stone*
Aislinn Stone

Kim Creech
Kim Creech

Sherry Sullivan
Mayor Sherry Sullivan



MEMO

To: Kimberly Creech, Treasurer
From: Delores A Brandt
Delores A Brandt, Purchasing Manager

Date: May 26, 2021

Re: Greensheet --CC Approval procurement of budgeted request for ONE (1) 2021--F250 Super Cab (Extended) 4X2 Truck and Service body for the Water Department

Sherry Sullivan
Mayor

Council Members:
Kevin G. Boone
Jack Burrell, ACOMO
Jimmy Conyers
Corey Martin
Jay Robinson

Lisa A. Hanks, MMC
City Clerk

The Water and Sewer Department Superintendent, Jason Langley, is requesting procurement of **ONE (1) 2021) -- F250 Super Cab (Extended) 4X2 Truck and Service body**. The Water and Sewer budgeted amount is \$42,000 . Best pricing is from the **State of Alabama, Vehicle Contract T193-A MA999 20000000114** through STIVER'S FORD LINCOLN in Montgomery, AL.

The quote for ONE (1)) 2021-- F250 Super Cab (Extended) 4X2 Truck and Service body includes delivery fee of approximately \$270. The estimated cost of the truck and body plus required options is **THIRTY-EIGHT THOUSAND EIGHT HUNDRED TWENTY-FOUR DOLLARS (\$38,824.00)**.

The State contract vendor is **STIVER'S FORD LINCOLN in Montgomery, AL**.

NOTES:

See Attached Vendor CUT-SHEET printout for details.
Delivery/pickup: this is in stock-- 3-4 weeks ARO

Please compose a greensheet and place on the next available City Council Agenda this request to approve budgeted procurement for one (1)) 2021-- F250 Super Cab (Extended) 4X2 Truck and Service body, from STIVER'S FORD LINCOLN in Montgomery, AL, for the Water and Sewer Dept for \$38,824.00.

161 North Section
Street PO Drawer 429
Fairhope, Alabama
36533

251-928-2136

251-928-6776 Fax
www.fairhopeal.gov

CC file, Jason Langley, Tim Bung, Clint Steadham

CITY OF FAIRHOPE PURCHASING DEPARTMENT REQUEST FORM

Name: Jason S Langley

Date: 2/21/2021

Department: Water & Sewer

ITEM OR SERVICE INFORMATION

- 1. What item or service do you need to purchase?** Ford F250 w/service body
- 2. What is the total cost of the item or service?** \$38824.00
- 3. Where will the item or service be physically located?** 555 S. Section Street
- 4. What is the primary function of the item or service?** For Electrician to utilize working on water and sewer infrastructure.
- 5. How many do you need?** One
- 6. Item or Service Is:** New Used Replacement Annual Request
- 7. When do you anticipate implementation?** Soon as possible
- 8. Additional Information or Comments:** Truck is needed for Electrician to utilize with a utility body. Pickup he is currently using will be utilized in our department to replace older vehicle per Tim Bung (Fleet Manager)
- 9. Vendor Name:** Stivers Automotive
- 10. Vendor Number:** Click or tap here to enter text.

BUDGET INFORMATION

- 1. Is it budgeted?** Yes No Emergency Request
- 2. If budgeted, what is the budgeted amount?** 42.000
- 3. What is the Capital Project Name or Budget Code:** 004-16300
- 4. Check any applicable boxes:** State Contract ALDOT Purchasing Group
 Sole Source (Attach Sole Source Justification)

Email completed form with quotes and other supporting documentation to deedee.brandt@fairhopeal.gov and jennifer.bush@fairhopeal.gov.

Craig McAdams
334-613-5000
334-613-5018 fax

STIVERS FORD LINCOLN
4000 EASTERN BLVD
MONTGOMERY, AL 36116

Effective Date: 5/25/2021
Version: 21.0

2021 FORD F250 REGULAR CAB 4x2 CHASSIS ONLY - FAIRHOPE WATER DEPT

CONTRACT NUMBER: MA999 20000000114 (T193A) **LINE NUMBER:** 1 **CONTRACT AMOUNT:** \$22,797

INCLUDES: 6.2L V8 385 Horsepower FFV Engine, 6 Spd Auto, 4x2, 142" Wheelbase, 56" Cab-to-Axle; 10,000 lbs. GVWR; Ford SYNC

STATE CONTRACT PRICE (T193A)			
X2A	Upgrade to 2021 Super Cab (Extended Cab)	\$	22,797
164	Super Cab Wheelbase - 164" w/ 66" Cab-to-Axle	\$	3,725
996	6.2L V8 385 Horsepower		Included
X37	3.73 Regular Axle		Std
66D	Pickup Box Delete - Requires 164" Wheelbase (does not include Spare Tire, Wheel & Jack)	\$	(425)
512	Spare Tire, Wheel and Jack	\$	295
63R	HD Rear Stabilizer w/ Aux Spring (recommended for Service Body applications)	\$	125
TD8	LT245/75Rx17E BSW AS		Std
872	Rear View Camera & Prep Kit (to be installed by Body Upfitter)	\$	415
66S	Upfitter Switches (6 Toggle Switches) - HD Alternator (Code 67D) included at NC	\$	165
67D	200 Amp. HD Alternator		NC
90L	Power Windows, Locks, Trailer Tow Mirrors and Power Tailgate Lock, Remote Keyless Entry	\$	865
52B	Trailer Bake Controller	\$	270
525	Cruise Control	\$	235
592	Roof Clearance Lights	\$	95
KEYs	Two (2) Extra Keys w/ FOBs	\$	360
LED	4-LED Corner Strokes	\$	649
SL98SW	Reading SL Service Body, Recessed Poched Bumper, T-Handles, Install Rear View Camera.	\$	8,732

COLOR:

Z1 Oxford White ** NC

INTERIOR:

AS 40/20/40 Vinyl Seats - Medium Earth Gray (XL) Std

DELIVERY - \$1.50 PER MILE ONE-WAY

\$ 270

Total Price (each)

\$ 38,824

STATE CONTRACT TERMS:

PAYMENT DUE AT TIME OF DELIVERY

SIGNATURE: (Required)

DATE: (Required)

PURCHASE ORDER NUMBER: (Required)

quantity: (Required)

Craig McAdams
334-613-5000
334-613-5018 fax

STIVERS FORD LINCOLN
4000 EASTERN BLVD
MONTGOMERY, AL 36116

Effective Date: 5/25/2021
Version: 21.0



X
X
X
X
X
X
X
X
X
X
X
X
X
X
X
X
X
X
X
X
X
X

X

X

X

RESOLUTION NO. _____

BE IT RESOLVED BY THE GOVERNING BODY OF THE CITY OF FAIRHOPE, ALABAMA, that the City of Fairhope approves the request from Sarah Fischer, Site Director of Prism United Fairhope, to hold a Chalk Event on the sidewalks in South Beach Park on Saturday, June 25, 2021 from 5:00 p.m. to 8:00 p.m.; and to put up a table to provide information about its program, distribute flyers and buttons, and provide chalk and water. Prism United Fairhope is dedicated to serving the needs of the LGBTQ+ youth of Fairhope and the surrounding areas.

ADOPTED THIS 14TH DAY OF JUNE, 2021

Jack Burrell, Council President

Attest

Lisa A. Hanks, MMC
City Clerk

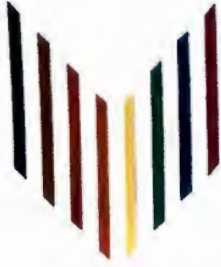

PRISM UNITED

Find Community. Be Yourself.

Thursday, May 27, 2021

Re: Proposed use of sidewalks for June 25th, 2021

Dear City Council of Fairhope,

I am writing to request use of public sidewalk space for a chalk event to be sponsored by Prism United Fairhope. I have included what I believe is all relevant information below. I would be happy to provide any additional information as needed on or before the June 14th Council Meeting.

Sincerely,

Sarah Fischer,
Site Director
Prism United Fairhope

- Requesting Party:
 - Sarah Fischer, Site Director of Prism United Fairhope
- Contact Info:
 - sarahfischer@prismunited.org
 - 901-409-4262
 - P.O. Box 834 Fairhope, AL 36533
- Requested Date:
 - Saturday, June 25th, from 5:00 p.m. – 8:00 p.m. (time can be adjusted as needed)
- Requested Location:
 - Sidewalks around Municipal Park
 - ✓ Sidewalks in South Beach Park
 - Sidewalks in Utopia Park
 - Sidewalks at the corner of Church St. and De La Mare



PRISM UNITED

Find Community. Be Yourself.

- **Requested Use:**
 - Prism United Fairhope would like to invite Fairhope community members to join them in decorating the sidewalks (in the area approved and designated by Council) with chalk to celebrate Pride and the LGBTQ community of Fairhope and the surrounding areas.
 - Prism United Fairhope would also plan to set up a standard folding table (approx. 3' x 6') adjacent to the chalking area at which to provide information about its programs, distribute flyers and buttons, and provide chalk and water.
- **Further Information/Attachments/Links**
 - Prism United Fairhope, a chapter of Prism United, is dedicated to serving the needs of the LGBTQ+ youth of Fairhope and the surrounding areas.
 - Further information about Prism United Fairhope can be found at <https://prismunited.org>
 - Please find attached photos of last year's Pride participation during the city's Chalk the Walk event. Though that group participation was sponsored under the umbrella of Rainbow Mobile, the event was organized and run by Sarah Fischer, Site Director of Prism United Fairhope, who is filing this request.



PRISM UNITED

Find Community. Be Yourself.

Images from June 27, 2020 Sidewalk Event sponsored by Rainbow Mobile:



RESOLUTION NO. ____

BE IT RESOLVED BY THE GOVERNING BODY OF THE CITY OF FAIRHOPE, ALABAMA, as follows:

[1] That the City of Fairhope has voted to purchase a 2022 F350 Crew Cab 4x4 DWR Pickup Truck for the Fairhope Volunteer Fire Department; and the type of vehicle needed is on the Alabama State Department of Purchasing bid list and therefore does not have to be let out for bid; and

[2] The following is the Alabama State Department of Purchasing contract information:

Bid Number: T191A

2022 Ford F350 Crew Cab 4x4

Cost is \$48,272.00

Adopted on this 14th day of June, 2021

Jack Burrell, Council President

Attest:

Lisa A. Hanks, MMC
City Clerk

City of Fairhope
Project Funding Request

Issuing Date: 6/10/2021

Please return this Routing Sheet to Treasurer by: ASAP

Project Name: Procurement of 2022 F350 Crew Cab 4x4 DWR Pickup Truck for the Fairhope Volunteer Fire Dept

JUN 10 '21 PM 3:40

JAN

Project Location: Fire Dept

Presented to City Council: 6/14/2021

Funding Request Sponsor: Chris Ellis, Fire Chief

Resolution # :
Approved _____

Changed _____

Rejected _____

Project Cash Requirement Requested:
Cost: \$ 48,272.00

\$ _____

Vendor: Stivers Ford Lincoln

Project Engineer: n/a

Order Date: n/a

Lead Time: n/a

Department Funding This Project

General Gas Electric Water Sewer Gas Tax Cap Project Impact Health Fed Grant

Department of General Fund Providing the Funding

Admin-10 Bldg-13 Police-15 **Fire-20** ECD-24 Rec-25 Civic-26 Street-35 Sanitation-40
Fac Maint-45 Golf-50 Golf Grounds-55 Museum-70 NonDeptFac-75 Debt Service-85 Marine-34 Plan/Zone

Project will be:

Expensed _____
Capitalized XXX
Inventoried _____

Funding Source:

Operating Expenses _____
Budgeted Capital XXX
Unfunded _____

Expense Code: 001200-50470
G/L Acct Name: Capital Purchases Vehicles & Equipment

Grant: \$0.00 Federal - not to exceed amount
State _____
City _____
Local _____

Project Budgeted: \$ 48,272.00 Draft FY22
Balance Sheet Item Included in projected cash flow

Over (Under) budget amount: \$ _____

Bond: _____ Title _____ Year _____
Loan: _____ Title _____ Year _____

Comments:

Procurement through Impact Fees

Capital Lease: _____ - Payment _____ Term _____

City Council Prior Approval/Date? _____

Senior Accountant

City Treasurer

Mayor

Purchasing Memo Date: 6/10/2021

Purchasing Memo Date: 6/10/2021

Payment To Date: 6/10/2021

Request Approved Date: 6/10/2021

Request Approved Date: 6/10/2021

Signatures: Aislinn Stone
Aislinn Stone

Kim Creech
Kim Creech

Sherry Sullivan
Mayor Sherry Sullivan



MEMO

Sherry Sullivan
Mayor

Council Members:
Kevin G. Boone
Jack Burrell, ACMO
Jimmy Conyers
Corey Martin
Jay Robinson

Lisa A. Hanks, MMC
City Clerk

Kimberly Creech
Treasurer

To: Aislinn Stone, Senior Acct
Kimberly Creech, Treasurer

From: Delores A Brandt
Delores A Brandt, Purchasing Manager

Date: June 10, 2021

Re: **Greensheet --CC Approval of budgeted over \$15,000 request for one (1) 2022 F350 Crew Cab 4X4 DWR Pickup with 179" wheelbase for the Fairhope Volunteer Fire Department**

The Fire Chief, Chris Ellis, is requesting procurement of **ONE (1) 2022 F350 CREW Cab 4X4 DWR Pickup truck** through use of IMPACT fees in amount of **\$48,272.00**. The best pricing is through the **State of Alabama CONTRACT Number MA999 2000000114 #T191-A**

One (1) 2022 Ford F350 Crew Cab 4X4 DWR Pickup with 179" wheelbase including delivery of \$270.00. Delivered cost is **FORTY-EIGHT THOUSAND TWO HUNDRED SEVENTY-TWO DOLLARS (\$48,272.00)**. The State contract vendor is **Stivers Ford Lincoln** of Montgomery, Al.

NOTES:

See Attached Vendor CUT-SHEET printout for details.
Delivery DECEMBER 2021

Please compose a greensheet and place on the next available City Council Agenda this request to approve procurement through IMPACT fees for ONE (1) 2022 F350 CREW Cab 4X4 DWR Pickup truck from Stivers Ford Lincoln of Montgomery, Al. through the State of Alabama T191A, for the Fairhope Volunteer Fire Department, for \$48,272.00

151 North Section St.
PO Drawer 429
Fairhope, AL 36533

CC file, Firechief Ellis, Clint Steadham

251-928-2136 (p)
251-928-6776 (f)
www.fairhopeal.gov

Craig McAdams
334-613-5000
334-613-5018 fax

STIVERS FORD LINCOLN
4000 EASTERN BLVD
MONTGOMERY, AL 36116

Quote Dated: 6/10/2021
Version: 22.0

2022 FORD F350 CREW CAB 4x4 CHASSIS - FAIRHOPE FIRE

CONTRACT NUMBER: MA999 2000000114 (T193A)

LINE NUMBER: 3

CONTRACT AMOUNT: \$38,181

STATE CONTRACT PRICE (T191A)

		\$ 38,181	<input checked="" type="checkbox"/>
W3D	UPGRADE FROM SUPER CAB 4x2 CHASSIS CAB to F350 CREW CAB DRW PICKUP 4x4 - 179" Wheelbase (8' Box)	\$ 5,586	<input checked="" type="checkbox"/>
99T	6.7L V8 Diesel w/ 10-speed Automatic Transmission (Includes PTO Provision)	Included	<input checked="" type="checkbox"/>
98R	Operator Command Regeneration (Diesel)	\$ 250	<input checked="" type="checkbox"/>
TBM	LT245 BSW AT 17 Ply	\$ 165	<input checked="" type="checkbox"/>
X4N	4.10 Limited Slip Rear Axle	\$ 360	<input checked="" type="checkbox"/>
90L	Power Windows, Locks & Trailer Tow Mirrors	\$ 1,125	<input checked="" type="checkbox"/>
41P	Skid Plates	\$ 165	<input checked="" type="checkbox"/>
18B	Cab Steps - Black Molded	\$ 445	<input checked="" type="checkbox"/>
43C	110V/400W Outlet	\$ 175	<input checked="" type="checkbox"/>
66S	Upfitter Switches	\$ 165	<input checked="" type="checkbox"/>
67D	240 Amp Alternator	NC	<input checked="" type="checkbox"/>
76C	External Backup Alarm	\$ 140	<input checked="" type="checkbox"/>
873	Rear Camera (located in CHMSL)	\$ 200	<input checked="" type="checkbox"/>
LED	4 Corner Strobes - White/White	\$ 685	<input checked="" type="checkbox"/>
KEY	Two (2) Extra Keys	\$ 360	<input checked="" type="checkbox"/>

EXTERIOR COLOR:

PQ Race Red NC

INTERIOR:

AS 40/20/40 Vinyl Seats - Medium Earth Gray (XL) Std

DELIVERY - \$1.50 PER MILE ONE-WAY

\$ 270

Total Price (each)

\$ 48,272

STATE CONTRACT TERMS:

PAYMENT DUE AT TIME OF DELIVERY

SIGNATURE: (Required)

DATE: (Required)

PURCHASE ORDER NUMBER: (Required)

Quantity: (Required)

INFORMATION: PICKUP OR DELIVERY IS REQUIRED NO LATER THAN FIVE (5) DAYS AFTER NOTICE OF READY FOR DELIVERY

Delivery - Dec, 2021

Dee Dee Brandt

From: Kimberly Creech
Sent: Tuesday, June 8, 2021 5:58 PM
To: jburrell26@bellsouth.net; Lisa A. Hanks, MMC
Cc: Mark Poillucci; dcombs5820@gmail.com; Fire Chief; firechief@fairhopevfd.org; Sherry Sullivan; Clint Steadham; Randy Weaver; Dee Dee Brandt; Cory Pierce
Subject: RE: FVFD Squad 2 Project

Jack,

Randy Weaver is still working on get a quote from the vendor. Hopefully, we can have the quote in the morning.

Thanks,
Kim

From: jburrell26@bellsouth.net <jburrell26@bellsouth.net>
Sent: Sunday, June 6, 2021 10:40 AM
To: Kimberly Creech <kim.creech@fairhopeal.gov>; Lisa A. Hanks, MMC <Lisa.Hanks@fairhopeal.gov>
Cc: Mark Poillucci <mpoillucci@fairhopevfd.org>; dcombs5820@gmail.com; Fire Chief <Fire.Chief@fairhopeal.gov>; firechief@fairhopevfd.org; Sherry Sullivan <sherry.sullivan@fairhopeal.gov>
Subject: FW: FVFD Squad 2 Project

SENT FROM AN EXTERNAL ADDRESS

Lisa, Kim,

Can we get this on the next council agenda for which we have the opportunity (start jumping through the hoops). As with all of our other vehicle orders, this is going to take quite a while to receive – definitely into next budget year, but we need to order ASAP. We have already discussed the funding. (Kim, let's make sure the Impact fees are not expiring before this Oct. 1.

I'm pretty sure the truck is on the state bid list – that is what I was told.

Let me know what details you need as I am going to assume you probably need a little more detail.

Thank you!

Jack

Cc: Mark Poillucci, Asst. Chief Dalton Combs, Chief Chris Ellis, Mayor Sullivan

From: Dalton Combs <dcombs5820@gmail.com>
Sent: Friday, June 4, 2021 12:25 PM
To: jack.burrell@fairhopeal.gov
Cc: Mark Poillucci <mpoillucci@fairhopevfd.org>; Fire Chief <firechief@fairhopevfd.org>; David Thomas

<dm_thomas4@yahoo.com>; Kevin Winingar <kevinwiningar@gmail.com>

Subject: FVFD Squad 2 Project

SENT FROM AN EXTERNAL ADDRESS

Good afternoon sir,

Attached is the spreadsheet on the Squad 2 vehicle that the FVFD would like to purchase using IMPACT fee money. The vehicle is off of state contract but the other equipment would be bought from local vendors. As you know the chip shortage on vehicles has this pushed out to the end of the year if we were to order now. Please let me know if there is anything else you need from us.

Respectfully,

Dalton Combs
Assistant Chief
Fairhope Vol. Fire Dept.
251-586-2306

RESOLUTION NO. _____

BE IT RESOLVED BY THE GOVERNING BODY OF THE CITY OF FAIRHOPE, ALABAMA, as follows:

[1] That the City of Fairhope has voted to procure a Replacement Chiller Unit for the Fairhope Public Library with a 90T York Air Cooled Chiller; and the equipment is available for direct procurement through the NCPA Cooperative which has been nationally bid; and therefore, does not have to be let out for bid with a cost of \$88,125.25.

Adopted on this 14th day of June, 2021

Jack Burrell, Council President

Attest:

Lisa A. Hanks, MMC
City Clerk

City of Fairhope
Project Funding Request

Issuing Date: 6/10/2021

Please return this Routing Sheet to Treasurer By: ASAP

JUN 10 2021 9:51:40

Handwritten initials

Project Name: Procurement of replacement chiller unit for Library from Johnson Controls, Inc.

Project Location: Library

Presented to City Council: 6/14/2021

Resolution # :
Approved _____
Changed _____
Rejected _____

Funding Request Sponsor: Richard Johnson, Public Works Director
George Ladd, Supervisor Streets and Facilities Maintenance

Project Cash Requirement Requested:
Cost: \$ 88,125.25

Vendor: Johnson Controls Inc through NCPA Cooperative

Project Engineer: n/a

Order Date: n/a

Lead Time: n/a

Department Funding This Project

General Gas Electric Water Sewer Gas Tax Cap Project Impact Health Fed Grant

Department of General Fund Providing the Funding

Admin-10 Bldg-13 Police-15 Fire-20 ECD-24 Rec-25 Civic-26 Street-35 Sanitation-40
Fac Maint-45 Golf-50 Golf Grounds-55 Museum-70 NonDepFac-75 Debt Service-85 Marina-34 Plan/Zone

Project will be:

Expensed _____
Capitalized XXX
Inventoried _____

Funding Source:

Operating Expenses _____
Budgeted Capital XXX
Unfunded _____

Expense Code: 001750-50373
G/L Acct Name: Library Capital Purchases

Grant: \$0.00 Federal - not to exceed amount
State _____
City _____
Local _____

Project Budgeted: \$ 137,287.00
Balance Sheet Item Included in projected cash flow

Over (Under) budget amount: \$ (49,161.75)

Bond: _____ Title _____ Year _____
Loan: _____ Title _____ Year _____

Comments:

Capital Lease: _____ - Payment _____ Term _____

City Council Prior Approval/Date? _____

Senior Accountant

City Treasurer

Mayor

Purchasing Memo Date: 6/10/2021

Purchasing Memo Date: 6/10/2021

Delivered To Date: 6/10/2021

Request Approved Date: 6/10/2021

Request Approved Date: 6/10/2021

Approved Date: _____

Signatures: *Aislinn Stone*
Aislinn Stone

Kim Creech
Kim Creech

Sherry Sullivan
Mayor Sherry Sullivan



MEMO

To: Aislinn Stone, Senior Acct
Kimberly Creech, Treasurer

From: Delores A Brandt
Delores A. Brandt, Purchasing Manager

Shery Sullivan
Mayor

Council Members:
Kevin G. Boone
Jack Burrell, ACMO
Jimmy Conyers
Corey Martin
Jay Robinson

Lisa A. Hanks, MMC
City Clerk

Kimberly Creech
Treasurer

Date: June 10, 2021

Re: **Council Approval and Greensheet – for replacement Chiller Unit in Library**

The Building Maintenance Departments has need to replace the Chiller Unit at the Library. The Current unit is a TRANE, and the replacement will be a YORK Chiller Unit.

Quotes were obtained for a TRANE replacement, and a new replacement Unit from YORK, through a Purchasing Group. The lowest quote was from Johnson Controls, Inc. through **NCPA Contract #02-55, for EIGHTY-EIGHT THOUSAND ONE HUNDRED TWENTY-FIVE DOLLARS AND TWENTY-FIVE CENTS (\$88,125.25)**

Please place on the next available City Council Agenda this request for Approval of procurement of replacement chiller unit for Library from Johnson Controls, Inc through NCPA Cooperative contract

Cc: , R Johnson, George Ladd, Randy Weaver, Clint Steadham

161 North Section St.
PO Drawer 429
Fairhope, AL 36533

251-928-2136 (p)
251-928-6776 (f)
www.fairhopeal.gov



Region XIV Education Service Center

1850 Highway 351
Abilene, TX 79601-4750
325-675-8600
FAX 325-675-8659

Monday, May 3rd, 2021

Johnson Controls, Inc.
ATTN: Andrew Pergande
507 E. Michigan Street
Milwaukee, WI 53202

Re: Annual Renewal of NCPA contract #02-55

Dear Andrew:

Region XIV Education Service Center is happy to announce that Johnson Controls, Inc. has been awarded an annual contract renewal for HVAC Equipment, Installation, Service & Related Products in Alabama based on the proposal submitted to Region XIV ESC.

The contract will expire on August 31st, 2022, completing the fourth year of a possible five-year term. If your company is not in agreement, please contact me immediately.

If you have any questions or concerns, feel free to contact me at 325-675-8600.

Sincerely,

A handwritten signature in black ink, appearing to read 'Shane Fields', is written over a light blue horizontal line.

Shane Fields
Region XIV, Executive Director



Proposal

Gulf Coast Common Branch
764B LAKESIDE DR
MOBILE, AL 36693-5114
Phone: 866-607-6878
Fax: 866-867-3608

TO: City of Fairhope
501 Fairhope Ave.
Fairhope, AL

Date: June 4, 2021
Project: Fairhope Public Library Chiller
Change Out

Richard Johnson

Executive Summary:

Johnson Controls is pleased to have the opportunity to propose this project. Johnson Controls was asked to provide a turn-key solution for replacing an existing 90 ton Trane Air Cooled Chiller. The existing chiller is having issues with the coil being in poor condition and the compressors failing. This is leading to high head pressure which causes the chiller to shut down and not perform to its capabilities and creates higher repair cost.

The new York or Trane chiller will have separate controls built into them. However, in the near future, it is our recommendation to upgrade the controls on the overall library for an overall view of the HVAC equipment at the library and potentially the whole city. **The controls upgrade with remote monitoring capability would allow a Johnson Controls certified technician to diagnose and view any alarms directly from their smartphone device. This would drastically eliminate or reduce any down time on any equipment.**

Using the buying influence, NCPA, we propose this project with two different prices based on which chiller is chosen by the customer to install. This presents two options between a York 90T Air

Cooled Chiller, and a Trane 90T Air Cooled Chiller. Both options are like for like replacements but the York chiller would require a little more piping. The NCPA contract number can be given at the time of award.

Scope of Work:

Johnson Controls will execute this project during the week at normal labor rates. Johnson Controls will provide the following materials and execute the following:

- 90T Air Cooled York Chiller, 90T Air Cooled Trane Chiller- Options given for customer preference- **All chiller options are high efficiency and with coated coils. Also, chillers are all priced with 10 year parts and labor warranty.**
- Crane with spreader bar for hoisting and rigging
- Piping for new chiller
- Butterfly Valves
- Insulation of new chiller piping

Electrical connections are expected to be like for like, therefore there is no cost built in for an electrician. If, connections are not like for like and an electrician is required, Johnson Controls will contract this trade with a change order.

The existing controls to the existing chiller will function with the new chiller. A chiller upgrade is recommended at a different cost or project. A controls upgrade with remote monitoring would give Johnson Controls the ability to diagnose and view the chillers using their smart device. **The technician could view any alarms and prepare for any necessary repairs prior to making a site visit.**

Project Pricing:

- **Option 1: 90T York Air Cooled Chiller- \$88,125.25**
 - **Model- YLAA0092**
 - **Priced with Louvered Panels and Isolation Valves**
 - **10 Year Warranty on Parts and Labor**
 - **Refrigerant Warrant Included- 18 Months**
 - **MCHX Warranty: 66 Months (5 Year) (Parts Only)**
 - **BACnet Connectivity**

- **Option 2: 90T Trane Air Cooled Chiller- \$131,565.51**
 - **Model- CGAM90**
 - **Priced with Louvered Panels and Isolation Valves**
 - **10 Year Warranty on Parts and Labor**
 - **1 Year Refrigerant Warrant**

Project Documents:



Design Conditions Datasheet

Unit Tag	Qty	Model No	Net Cooling Capacity (ton.R)	Nominal Voltage	Refrigerant Type
CH-1	1	YLAAD092HE46XFBSXTX	85.71	480-3-60.0	R410A

PH:

YLAAD092HE	46XFBSXTXA	SXBLXCXX44	SXXXXXHXXX	YAXGPXX7XX	XXXXXXXXXX			
...5...10	...5...20	...5...30	...5...40	...5...50	...5...60	...5...70	...5...80	...5...90

Evaporator Data		Evaporator Data (Cont.)		Performance Data	
EWT (°F)	64.00	Fluid Volume (USGAL)	8.771	EER (Btu/W-h)	10.98
LWT (°F)	44.00	Min. Flow Rate (USGPM)	99.88	IPLV.IP (Btu/W-h)	16.79
Design Flow Rate (USGPM)	204.8	Max. Flow Rate (USGPM)	400.1		
Evap. Press. Drop (ft H2O)	7.30				
Fluid	Water				
Strainer Press. Drop (ft H2O)	4.04	Condenser Data		Physical Data	
Ext. Kit Press. Drop (ft H2O)	2.29	Ambient Temp. Design (°F)	95.0	Rigging Wt. (lb)	5227
Total Press. Drop (ft H2O)	13.8	Altitude (ft)	0.000	Operating Wt. (lb)	5300
Fouling Factor (h.ft².F/Btu)	0.000100	Compressor Type	Scroll - Hermetic	Refrigerant Charge (lb)	103.8

Electrical Data

Circuit	1	2	3	4
Compressor RLA	27 / 27 / 27	27 / 27 / 27		
Fan QTY/FLA (each)	3 / 4	3 / 4		
High LRA Current	180 / 180 / 180	180 / 180 / 180		

Single Point

Min. Circuit Ampacity	196		
Recommended Fuse/CB Rating	200		
Max. Inverse Time CB Rating	200		
Max. Dual Element Fuse Size (A)	200		
Unit Short Circuit Withstand (STD)	5 [kA]		
Wires Per Phase	1		
Wire Range (Lug Size)	#8 AWG - 500 kcmil		
Starter Type	Across The Line		

Operating Condition Electrical Data	
Compressor kW	83.62
Total Fan kW	10.08
Total kW	93.70

Notes:

Certified in accordance with the AHRI Air-Cooled Water-Chilling Packages Using Vapor Compression Cycle Certification Program, which is based on AHRI Standard 550/590 (I-P) and AHRI Standard 551/591 (SI). Certified units may be found in the AHRI Directory at www.ahridirectory.org. Auxiliary components included in total kW - Oil heaters, Chiller controls. Auxiliary power is already included in the compressor and fan power



ASHRAE Standard 90.1-2010 and ASHRAE Standard 90.1-2013 & 2016 Compliant.

Compliant with the requirements of the LEED Energy and Atmosphere Enhanced Refrigerant Management Credit (EA04).



Design Conditions Datasheet

Part Load Rating Data				
Stage	Ambient (°F)	Capacity (ton.R)	Total kW	Unit Efficiency (Btu/W-h)
1	95.0	85.71	93.70	10.98
2	87.4	74.88	70.12	12.81
3	78.9	62.68	51.13	14.71
4	69.1	48.73	34.39	17.00
5	58.3	33.25	19.98	19.98
6	55.0	18.29	9.402	20.79

Sound Power Levels (In Accordance with AHRI 370)										
Stage	Ambient (°F)	63 Hz (dB)	125 Hz (dB)	250 Hz (dB)	500 Hz (dB)	1 kHz (dB)	2 kHz (dB)	4 kHz (dB)	8 kHz (dB)	LWA
1	95.0	98	97	93	93	89	88	83	79	95
2	87.4	97	96	92	92	88	87	82	78	94
3	78.9	96	95	91	91	87	86	81	77	93
4	69.1	95	94	90	90	86	84	80	76	92
5	58.3	93	92	88	88	84	83	78	74	90
6	55.0	90	89	85	85	81	80	75	71	87

Note: Unit is equipped with Low Sound Fans.

Measurement of sound pressure used to obtain the sound power data presented is based on AHRI-370.

Air-cooled chillers are rated in terms of sound power not sound pressure. Johnson Controls provides estimates of sound pressure, but this is not the rating metric.

For an air-cooled chiller, sound pressure calculated from sound power varies depending on how the chiller is assumed to behave, i.e. the radiation model. In other words, determining sound pressure from sound power requires making assumptions that result in different answers at a given distance from the chiller. The environment also influences sound pressure in the field installation. Sound pressure estimation radiation models pertaining to air-cooled chillers include the 'traditional' hemispherical model, parallelepiped model and equivalent hemispherical model.

Regarding sound power, Johnson Controls references tolerance limits based on ASHRAE guidelines. These are +/- 6dB in the 63Hz octave band, +/- 4dB in all other octave bands and +/- 3dB for the overall dBA.

Tolerance limits are based on uncertainties associated with:

1. Measurement Test Procedure
2. Repeatability
3. Production / Manufacturing Variability

Standard deviation associated with air-cooled chiller sound data is a measure of spread i.e. it indicates the range of probability of sound levels. Note that for operating conditions other than AHRI's Standard Rating Condition, higher levels of uncertainty can be expected.

Lead times for factory performance testing depend on test laboratory availability. Please confirm with Johnson Controls Customer Service.

Performance at AHRI Conditions					
Evaporator Data		Condenser Data		Performance Data	
EWT (°F)	64.00	Ambient Temp. (°F)	95.0	EER (Btu/W-h)	10.98
LWT (°F)	44.00	Altitude (ft)	0.000	IPLV.IP (Btu/W-h)	16.79
Flow Rate (USGPM)	204.6			Net Cooling Capacity (ton.R)	85.71
Pressure Drop (ft H2O)	7.30				
Fluid	Water				
Fouling Factor (h.F/Btu)	0.000100				
Fluid Volume (USGAL)	8.771				

Note: Unit rated at design condition capacity.

INLET/OUTLET WATER
CONNECTION SIZE

4" (100mm)

BRAZE PLATE
WATER VOLUME/STORAGE

9.0 GAL (34.1 LITERS)

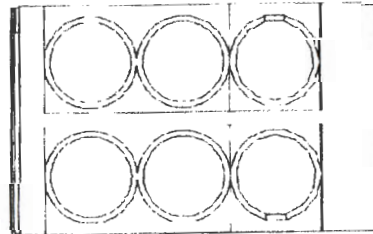

TOP VIEW

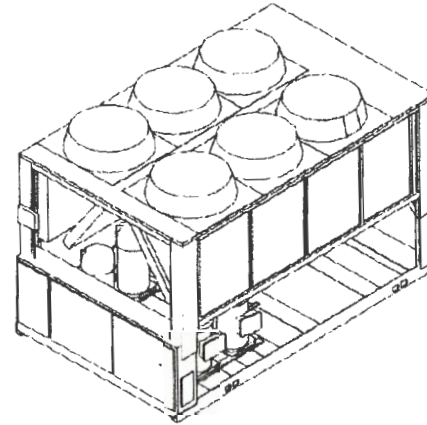

ISOMETRIC VIEW

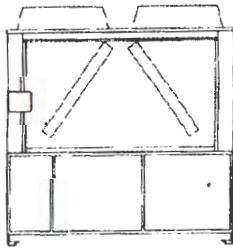

FRONT VIEW

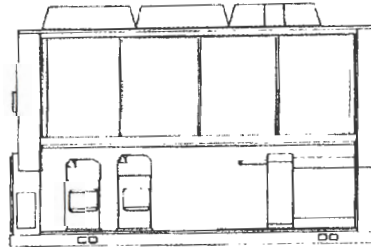

RIGHT SIDE VIEW

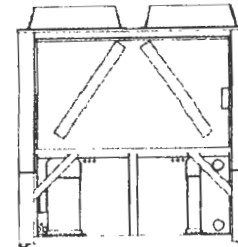

BACK VIEW



TRANE

305 2041104 4/17
Climate

Exclusions and Clarifications:

- Electrical is to be like for like, if not, a change order for an electrician would be required
- Schedule for work is during normal working hours- Monday-Thursday 10 Hour Days
- NCPA Buying Group is being used to propose project
- Permits not included

This proposal and alternates listed below are hereby accepted and Johnson Controls is authorized to proceed with work; subject, however to credit approval by Johnson Controls, Inc., Milwaukee, Wisconsin.

This proposal is valid until: July 5, 2021

Fairhope Public Library

Johnson Controls, Inc.

Name: _____
Title: _____
Date: _____
PO: _____

Name: _____
Title: _____
Date: _____

TERMS AND CONDITIONS

By accepting this proposal, Purchaser agrees to be bound by the following terms and conditions:

1. **SCOPE OF WORK.** This proposal is based upon the use of straight time labor only. Plastering, patching and painting are excluded. "In-line" duct and piping devices, including, but not limited to, valves, dampers, humidifiers, wells, taps, flow meters, orifices, etc., if required hereunder to be furnished by Johnson Controls, Inc. (hereinafter referred to as JCI), shall be distributed and installed by others under JCI's supervision but at no additional cost to JCI. Purchaser agrees to provide JCI with required field utilities (electricity, toilets, drinking water, project hoist, elevator service, etc.) without charge. JCI agrees to keep the job site clean of debris arising out of its own operations. Purchaser shall not back charge JCI for any costs or expenses without JCI's written consent unless specifically noted in the statement of the scope of work or services undertaken by JCI under this agreement, JCI's obligations under this agreement expressly exclude any work or service of any nature associated or connected with the identification, abatement, clean up, control, removal, or disposal of environment Hazards or dangerous substances, to include but not be limited to asbestos or PCSs, discovered in or on the premises. Any language or provision of the agreement elsewhere contained which may authorize or empower the Purchaser to change, modify, or alter the scope of work or services to be performed by JCI shall not operate to compel JCI to perform any work relating to Hazards without JCI's express written consent.
2. **INVOICING && PAYMENTS.** JCI may invoice Purchaser monthly for all materials delivered to the job site or to an off-site storage facility and for all work performed on-site and off-site. Ten percent (10%) of the contract price is for engineering, drafting and other mobilization costs incurred prior to installation. This 10% shall be included in JCI's initial invoice. Purchaser agrees to pay JCI the amount invoiced upon receipt of the invoice. Waivers of lien will be furnished upon request as the work progresses to the extent payments are received. If JCI's invoice is not paid within 30 days of its issuance, it is delinquent.
3. **MATERIALS.** If the materials or equipment included in this proposal become temporarily or permanently unavailable for reasons beyond the control and without the fault of JCI, then in the case of such temporary unavailability, the time for performance of the work shall be extended to the extent thereof, and in the case of permanent unavailability, JCI shall (a) be excused from furnishing said materials or equipment, and (b) be reimbursed for the difference between the cost of the materials or equipment permanently unavailable and the cost of a reasonably available substitute therefore.
4. **WARRANTY.** JCI warrants that the equipment manufactured by it shall be free from defects in material and workmanship arising from normal usage for a period of ninety (90) days from delivery of said equipment, or if installed by JCI, for a period of ninety (90) days from installation. JCI warrants that for equipment furnished and/or installed but not manufactured by JCI, JCI will extend the same warranty terms and conditions which JCI receives from the manufacturer of said equipment. For equipment installed by JCI, if Purchaser provides written notice to JCI of any such defect within thirty (30) days after the appearance or discovery of such defect, JCI shall, at its option, repair or replace the defective equipment. For equipment not installed by JCI, if Purchaser returns the defective equipment to JCI within thirty (30) days after appearance or discovery of such defect, JCI shall, at its option, repair or replace the defective equipment and return said equipment to Purchaser. All transportation charges incurred in connection with the warranty for equipment not installed by JCI shall be borne by Purchaser. These warranties do not extend to any equipment which has been repaired by others, abused, altered or misused, or which has not been properly and reasonably maintained. THESE WARRANTIES ARE IN LIEU OF ALL OTHER WARRANTIES, EXPRESS OR IMPLIED, INCLUDING, BUT NOT LIMITED TO, THOSE OF MERCHANTABILITY AND FITNESS FOR A SPECIFIC PURPOSE
5. **LIABILITY.** JCI shall not be liable for any special, indirect or consequential damages arising in any manner from the equipment or material furnished or the work performed pursuant to this agreement.
6. **TAXES.** The price of this proposal does not include duties, sales, use, excise, or other similar taxes, unless required by federal, state or local law. In addition to the stated price, purchaser shall pay all taxes not legally required to be paid by JCI or, alternatively, shall provide JCI with acceptable tax exemption certificates. JCI shall provide Purchaser with any tax payment certificate upon request and after completion and acceptance of the work.
7. **DELAYS.** JCI shall not be liable for any delay in the performance of the work resulting from or attributed to acts or circumstances beyond JCI's control, including, but not limited to, acts of God, fire, riots, labor disputes, conditions of the premises, acts or omissions of the Purchaser, Owner or other Contractors or delays caused by suppliers or subcontractors of JCI, etc.
8. **SCHEDULE.** JCI and Purchaser shall mutually agree upon a schedule for completion of the work. In the event Purchaser desires to change or accelerate the schedule or the schedule is otherwise accelerated, delayed, or impacted for reasons beyond the control of JCI, JCI shall be entitled to a change order equitably adjusting the compensation of JCI to account for the increased costs associated with such schedule changes.
9. **DISPUTES.** All disputes involving more than \$15,000 shall be resolved by arbitration in accordance with the rules of the American Arbitration Association. The prevailing party shall recover all legal costs and attorney's fees incurred as a result. Nothing here shall limit any rights under construction lien laws.
10. **INSURANCE.** Insurance coverage in excess of JCI's standard limits will be furnished when requested and required. No credit will be given or premium paid by JCI for insurance afforded by others.

11. INDEMNITY. The Parties hereto agree to indemnify each other from any and all liabilities, claims, expenses, losses or damages, including attorneys' fees, which may arise in connection with the execution of the work herein specified and which are caused, in whole or in part, by the negligent act or omission of the Indemnifying Party.

12. OCCUPATIONAL SAFETY AND HEALTH. The Parties hereto agree to notify each other immediately upon becoming aware of an inspection under, or any alleged violation of, the Occupational Safety and Health Act relating in any way to the project or project site.

13. LEGAL FEES. Purchaser agrees to pay and reimburse JCI for any and all reasonable legal fees which are incurred by JCI in the collection of amounts due and payable under this Agreement.

14. ENTIRE AGREEMENT. This proposal, upon acceptance, shall constitute the entire agreement between the parties and supersedes any prior representations or understandings.

15. CHANGES. No change or modification of any of the terms and conditions stated herein shall be binding upon Johnson unless accepted by Johnson in writing.

PARKING AUTHORITY

NOMINEE (S)

3 -Year Term

APPOINTMENTS

Chad Bartz

REAPPOINTMENTS

The term shall end June 2024



CITY OF FAIRHOPE

JUN 7 7 14 30 06

ZAH

APPLICATION FOR APPOINTMENT TO A CITY BOARD OR COMMITTEE

City Council seeks to have diversity in making appointment to boards and committees. It is the policy of the City Council to make appointments based on the needs of the City as well as the interests and qualifications of each applicant. In accordance with the Code of Alabama, all applicants must be qualified electors and taxpayers in the City, excluding the Planning Commission. All applications filed with the City Clerk will be public record.

Please return this application to the Fairhope City Clerk at City Hall, 161 North Section Street, Fairhope, Alabama 36532 or mail to City of Fairhope, Attention Fairhope City Clerk, P. O. Drawer 429, Fairhope, Alabama 36533.

PLEASE PRINT CLEARLY

Last Name: Bartz First Name: Chad
Phone Number: 928-6915 Cell: 635-5244 Email: Chadbartz1@gmail.com
Home Address: 9051 Pine Run Business: Mr. Gene's Beans 10m 302 De La Mare
City: Daphne State: AL Zip: 36527
Business Address: 302 De La Mare Ave.
City: Fairhope State: AL Zip: 36532
Name of Board or Committee: Parking Authority

EDUCATIONAL BACKGROUND:

1) see attached resume

PROFESSIONAL LICENSES AND/OR ASSOCIATIONS:

1) Fairhope Downtown Business Assoc; 2) National Automobik Dealers Assoc.

PROFESSIONAL EXPERIENCE:

1) see attached resume

CIVIL INTERESTS AND/OR SERVICE MEMBERSHIPS:

1) SIGN (Serving in Gods Name) A christian group serving orphans and widows, Spanish Fort AL; 2) Mens Bible Study Spanish Fort United Methodist; 3) Timber Creek POA Board for six years (two as president)

HOW WILL YOUR QUALIFICATIONS BEST SERVE THE NEEDS OF THE COMMUNITY?

my personal and professional experience working with people as a business owner will enable me to be an effective group member; my qualifications will help develop innovative solutions for downtown business owners and the

Signature: Chad Bartz Date: 6/2/21

You may attach a resume with this application. greater community of Fairhope.

CHAD C. BARTZ
9051 Pine Run, Daphne, AL 36527
(251) 635-5244 (C)
chadbartz1@gmail.com

SUMMARY

Twenty five years of increasing responsibility in sales, account management, customer marketing and small business ownership. Extensive experience in leading employees. Responsible for developing strategic business plans including sales and profit forecasts, P&L responsibility, marketing, capital and operating resource allocation. Minority owner/operator of new vehicle dealerships (Chevrolet & Hyundai) with sales in excess of \$47 million. Proven leadership, negotiating, problem-solving, analytical, verbal and written communication skills give me a competitive advantage that will make an immediate contribution to any organization.

PROFESSIONAL EXPERIENCE

Bay Climate Control LLC, April 2015 to December 2016
Owner/Operator, Alabama Gulf Coast area

- Lead air conditioning and refrigeration company. Motivate employees to perform to their highest level through leading by example, positive interactions and high expectations.
- Responsible for managing cash flow, working capital, earnings and expenses.
- Improved profits in 2015 and 2016 by 40%. SDE profit margin of 34% vs. an industry goal of 25%.
- Grew revenue by 32% in 20 months of ownership.
- Grew revenue by growing the customer base, increasing average work order amount and developing a reoccurring revenue model.

Chuck Stevens Automotive, April 2004 to December 2014
Vice President of Operations/Minority Owner, Atmore and Bay Minette, AL; Gautier, MS

- Assisted in creating and implementing Chuck Stevens Automotive's unique brand, differentiating our dealership from our competition. Success is built on four key strategies: our employees, brand identity, advertising strategy and community involvement.
- Lead dealership in daily operations, including managing 140 employees in sales, parts, service, accounting, and support staff. Motivate employees to perform to their highest level through leading by example, positive interactions and high expectations.
- Responsible for managing cash flow, working capital, earnings and expenses.
- Efficiently manage new and pre-owned inventory in excess of \$9 million resulting in maximum return on assets.
- Increased retail sales efficiency, which measures our performance vs. our competition. Our Ford and General Motors dealerships perform above 180% vs. our competitors, ranking us in the top five in Alabama.
- Improved profits in 2006, 2007 and 2008, exceeding \$1 million each year with a ROI of 33.2% vs. a regional average of 17.7%.
- Divested and consolidated automotive and recreational vehicle operations in 2009 when they became unprofitable as economic conditions changed. Saved the company \$300,000 in 2008 and 2009.
- Developed a productive employee base measured by an industry leading dollar sales per employee of \$69,566 vs. a group average of \$48,332.
- As minority owner/operator, assisted in leading dealership to our goal of becoming the largest seller of pre-owned vehicles in the state of Alabama in 2007 and 2008. Ford Motor Credit extended us their largest credit line to support our sales.

The Coca-Cola Company, Nashville, TN and Daphne, AL ***July 2001 to April 2004***
Business Development Manager, Southeast Area Sales, Coca-Cola USA Fountain

- Exceeded sales volume, profit and revenue objectives by 6%.
- Developed and executed comprehensive business plans utilizing cross functional team members to align customers' objectives and strategies with Coca-Cola Fountain's (CCF) resources to deliver profitable volume growth for all stakeholders within budget and planned schedule.
- Assessed, communicated and gained credit for the value that CCF brands, products and services add to customers' sales and profits resulting in the ability to sell against lower priced competitive offers while maintaining or improving CCF profit margins.
- Successfully sold cumulative price increases higher than CPI to 100% of my customers resulting in \$500,000 in incremental revenue.

AT&T, Atlanta, GA ***January 2001 to July 2001***
Business Manager, Mega Region, AT&T Business Services, Atlanta, GA

- Developed and implemented a monthly stewardship process with Bass Hotels & Resorts to differentiate AT&T from lower priced competitors.
- Trained account team to develop business plans aligning AT&T products and technical resources with our customer's growth, cost and marketing objectives.
- Developed and implemented a referral tracking process for five account executives resulting in \$1.2 million in new revenue.
- Trained client business managers, data sales and voice sales executives to effectively utilize AT&T sales funnel to increase revenue and sales.

The Coca-Cola Company, Atlanta, GA ***June 1996 to January 2001***
Area Account Executive II, Southeast Area Sales, Coca-Cola USA Fountain, Atlanta, GA

- Exceeded sales volume, profit and revenue objectives by 8%.
- Developed and operated within planned marketing, capital and operating budgets.
- Negotiated four new contracts with improved economic value added (EVA).
- 96% of customer contracts went to term realizing planned profit, revenue and sales volume.
- Lead customer in repositioning their brand resulting in an 8% increase in average unit sales.
- Lead operating team in the development of our mission, values and guiding principles.
- Liaison between The Coca-Cola Company and the Atlanta Olympic Committee to ensure prevalent presence of our brands at Olympic Stadium.
- Participated in the development of CCF's frozen carbonated beverage market positioning.
- Expanded CCF frozen brand exposure to 19 million young consumers in a strategic presence account.
- Developed and implemented Frozen Beverage University II training for account executives.

Ford Motor Company, Atlanta, GA and Memphis, TN ***January 1990 to June 1996***
Marketing Project Manager, Atlanta Region, Lincoln-Mercury Sales Division, Atlanta, GA, 6/95

- Developed and executed two new vehicle launches including a direct mail campaign, media purchases, salesperson training and a dealer human resource allocation model.
- Developed advertising strategies at the regional level that increased purchase intent among foreign car owners of Lincoln-Mercury products by 3%.
- Created an evaluation process to advise key dealerships on how to measure ROI, net profit, working capital, expense ratios and customer satisfaction against other top performing dealerships.
- Developed, presented and gained commitment from dealers for a product price increase generating an additional \$5.5 million in regional advertising.
- Managed and allocated a \$21 million regional advertising budget with an elected dealer council.
- Developed and executed two regional dealer incentive contests increasing retail sales by 7% and company wholesale by 8%.

Zone Manager, Lincoln-Mercury Sales Division, Memphis, TN and Atlanta, GA, 1/90

- Managed the second largest sales region in the country exceeding \$288 million in sales.
- Managed the highest gross profit sales region in the country exceeding \$98 million in gross profits.
- Increased sales by 11% vs. industry growth of 3% resulting in \$2.5 million in increased revenue.
- Developed business strategies (owner clinics, quarterly newsletters, repeat buyer incentives) that increased consumer loyalty by 6% to Lincoln-Mercury dealers.
- Evaluated three key dealers' sales, expense and profit margin results against other leading dealers and developed individual strategies to improve performance.
- Won national wholesale contest in 1991 and was runner-up in 1992.
- Awarded Zone Manager of the Month six times in two years based on retail and wholesale results.

EDUCATION

**St. Cloud State University, St. Cloud, MN
Bachelor of Science, Marketing and Speech Communications, 1989**

Lisa A. Hanks, MMC

From: Kimberly Creech
Sent: Monday, June 7, 2021 2:33 PM
To: Lisa A. Hanks, MMC; Jack Burrell; Jimmy Conyers
Cc: Sherry Sullivan; Jason Jarvis; Jennifer Olmstead
Subject: A/R write offs
Attachments: Outstanding Arrears Balance from AS400 05.18.21 without names.pdf; Outstanding Arrears Balance from AS400 05.18.21 with names.pdf

Please add to June 14th agenda. The file without names can be published. The total amount of \$614,485.95 are terminate account balance from the old system. Any balances less than 6 years can be collected per state law. The balances for terminated accounts from 2016 to 2019 are \$201,141.19. The balance older than 2015 are uncollectible. Our current system only allows writes offs for the old system arrears in one group write off.

Thanks,

Kim Creech

City Treasurer

City of Fairhope

P O Drawer 429

Fairhope, AL 36533

Email: Kim.creech@fairhopeal.gov



City of Fairhope

Write off Customer Terminated balances as of 6/01/2021

Customer Info	Property ID	Customer ID	Address 1	City	State	Zip Code	Total Unpaid	Stop Date
1003772-103061162	1003415	103061692	9639 COUNTY RD 24	FAIRHOPE	AL	36532	\$93.89	11/14/2011
1013681-117854728	1013553	117079112	198 AUTUMN DR LOT 11	FAIRHOPE	AL	36532	\$971.37	11/14/2011
1015974-117045936	1013768	117120738	9621 OTTAWA DR	DAPHNE	AL	36526	\$383.97	11/15/2011
1013779-117125695	1021299	121056985	14718 SCENIC HWY 98	FAIRHOPE	AL	36532	\$250.14	11/15/2011
1009071-110092841	1015500	117611208	21309 STATE HWY 181	FAIRHOPE	AL	36532	\$60.97	11/15/2011
1013561-117086553	1001596	102049957	PO BOX 899	FAIRHOPE	AL	36533	\$695.83	11/16/2011
1018459-119002364	1001956	102050346	323 RIDGEWOOD DR	DAPHNE	AL	36526	(\$5.96)	11/16/2011
1009107-110458754	1004978	104107854	P.O. BOX 262	MAGNOLIA SPGS	AL	36555	\$59.86	11/17/2011
1005301-104152877	1000528	121021368	82 PLANTATION PT #264	FAIRHOPE	AL	36532	\$29.54	11/17/2011
1004699-104104514	1005300	104125614	15591 COUNTY RD 49 #5	SUMMERDALE	AL	36580	\$49.91	11/17/2011
1009918-111069874	1013231	117045913	9556 COUNTY RD 34 #2	FAIRHOPE	AL	36532	\$83.68	11/18/2011
1013681-117854720	1006391	109046580	10165 MCLEOD RD	MOBILE	AL	36695	\$830.75	11/18/2011
1013685-117156902	1003077	103075250	P.O. BOX 1438	DAPHNE	AL	36526	(\$6.11)	11/23/2011
1001744-102042362	1022668	124002675	27154 STRATFORD GLENN DR	DAPHNE	AL	36526	\$119.66	11/28/2011
1013718-117135493	1007719	110026572	218 SIMON ST	FAIRHOPE	AL	36532	\$114.89	11/28/2011
1018980-119125404	1008549	110018004	8550 SOUTHWOOD CT APT D	FAIRHOPE	AL	36532	\$388.06	11/28/2011
1004491-104125633	1009920	111452600	806 N GREENO RD LOT 10	FAIRHOPE	AL	36532	\$1,028.96	11/30/2011
1009529-111012550	1009202	110095803	27670 HWY 98	DAPHNE	AL	36526	\$93.94	11/30/2011
1001590-102049994	1007217	110056992	10 CALL ST	FAIRHOPE	AL	36532	\$710.12	12/1/2011
1023731-125956482	1007347	110048103	18 HOBART AVE	PROVIDENCE	RI	02906	(\$9.08)	12/1/2011
1001124-101061406	1015019	117130517	404 BELLE CHASE CT	FAIRHOPE	AL	36532	\$990.96	12/1/2011
1018498-119003584	1005547	106008507	150 MORPHY AVE	FAIRHOPE	AL	36532	\$517.84	12/1/2011
1006760-110005383	1001124	101061406	P.O. BOX 808	BUTLER	AL	36904	\$413.06	12/2/2011
1021982-123154400	1000971	101055401	P.O. BOX 434	FAIRHOPE	AL	36533	\$220.02	12/5/2011
1003174-103061358	1000327	110014338	150 SHORT ST	FAIRHOPE	AL	36532	(\$0.70)	12/5/2011
1003173-103065516	1018615	119002038	2812 SLEVIN ST	LOUISVILLE	KY	40212	\$534.38	12/5/2011
1009920-111452605	1013242	117040819	9556 COUNTY RD 34 #24	FAIRHOPE	AL	36532	\$166.15	12/6/2011
1004125-103052024	1004978	104106619	12977 CHEELEYS CT	SUMMERDALE	AL	36580	\$44.32	12/6/2011
1007317-110048160	1017183	119123600	6655 TWIN BEECH RD	FAIRHOPE	AL	36532	\$219.89	12/7/2011
1017937-119003163	1015991	117040716	2419 GALE AVE	BALDWIN	NY	11510	\$305.68	12/7/2011
1013516-117126626	1017717	119000718	7048 TWIN BEECH RD	FAIRHOPE	AL	36533	\$109.86	12/7/2011
1016345-117745891	1009182	110964000	901 GAYFER AVE #1124	FAIRHOPE	AL	36532	\$598.81	12/7/2011
1007376-110055693	1000374	113035693	P.O. BOX 778	FAIRHOPE	AL	36533	\$814.49	12/9/2011
1006347-109020834	1004267	104256982	208 FAIRHOPE AVE APT 6	FAIRHOPE	AL	36532	\$604.53	12/13/2011
1006577-109058406	1005817	108012365	256 S SUMMIT	FAIRHOPE	AL	36532	\$205.78	12/13/2011
1006861-110254361	1005759	107027450	21 FELS AVE	FAIRHOPE	AL	36532	\$765.63	12/13/2011
1001086-101077405	1009097	110023802	711 NICHOLS AVE	FAIRHOPE	AL	36532	\$365.20	12/15/2011
1006248-109026640	1001611	102050947	1036 HOMEWOOD AVE	MELBOURNE	FL	32940	\$361.59	12/16/2011
1005596-106125607	1008981	110098749	957 DIEHL AVE	FAIRHOPE	AL	36532	\$399.64	12/16/2011
1006475-109025742	1008190	110014085	13017 GOPHER WOOD TR	TALLAHASSEE	FL	32312	\$29.54	12/16/2011
1009366-111237454	1018495	119002495	705 N PINE ST	FOLEY	AL	36535	(\$23.78)	12/16/2011
1014496-117325413	1023122	124002221	5908 STUMBERG LN #26	BATON ROUGE	LA	70816	\$97.51	12/19/2011
1014518-117325465	1007725	110096602	100 HOMESTEAD VLLG #74	FAIRHOPE	AL	36532	\$112.94	12/20/2011
1014990-117136528	1007586	110025750	101 HOMESTEAD APT 30	FAIRHOPE	AL	36532	\$91.80	12/20/2011
1001753-102045618	1006211	109025741	650 FAIRLAND AVE #F	FAIRHOPE	AL	36532	\$53.02	12/21/2011
1004497-104125768	1006983	110023799	322 LINCOLN	FAIRHOPE	AL	36532	\$1,018.31	12/21/2011
1019843-119568006	1017808	119257490	27642 US HWY 98 #917	DAPHNE	AL	36532	\$63.93	12/22/2011
1013943-117189070	1005674	107048596	207 S MOBILE ST #211	FAIRHOPE	AL	36532	\$68.35	12/22/2011
1005207-104125626	1011330	114024437	PO BOX 41834	BATON ROUGE	LA	70835	\$87.08	12/27/2011
1001008-101109067	1012354	116625410	2750 FLETCHER PK CIR	CORDOVA	TN	38016	\$81.21	12/28/2011
1005964-108028454	1015052	117130248	612 WESTCHASE CT S	FAIRHOPE	AL	36532	\$429.91	12/29/2011
1017721-119254879	1009184	110098474	2330 B LITTLE VALLEY RD	HOOVER	AL	35216	\$204.46	12/30/2011
1008227-110052360	1004497	104125747	18562 COUNTY RD 9 LOT A	SILVERHILL	AL	36576	\$62.86	1/3/2012
1017205-119856001	1015440	117611121	10243 MISSION TRACE	FAIRHOPE	AL	36532	\$102.97	1/3/2012
1003999-103008359	1015218	117620106	13100 STATE HIGHWAY 104	FAIRHOPE	AL	36532	\$195.18	1/3/2012
1018081-119004335	1002308	103061655	P O BOX 1012	POINT CLEAR	AL	36564	\$67.40	1/3/2012
1022111-124125713	1000369	113031431	155 ORANGE AVE	FAIRHOPE	AL	36532	\$943.48	1/4/2012
1006859-110025740	1009100	110085700	901 GAYFER AVE #623	FAIRHOPE	AL	36532	\$233.34	1/4/2012
1000919-101062504	1013578	117090070	224 EAST HIGHLAND AVE	PENSACOLA	FL	32503	\$223.96	1/5/2012
1004261-104006726	1024340	125930094	2621 VENICE CT	MOBILE	AL	36605	\$110.38	1/6/2012
1007217-110056992	1008536	110018076	21081 BISHOP RD #1	FAIRHOPE	AL	36532	\$166.04	1/9/2012
1005588-106029601	1000571	124080500	6901 CEDARBROOK DR	FAIRHOPE	AL	36532	(\$9.32)	1/11/2012

City of Fairhope

Write off Customer Terminated balances as of 6/01/2021

Customer Info	Property ID	Customer ID	Address 1	City	State	Zip Code	Total Unpaid	Stop Date
1008639-110452133	1013563	117086544	198 AUTUMN DR LOT 6	FAIRHOPE	AL	36532	\$641.69	1/12/2012
1015341-117854784	1002371	103063166	13550 GREENO RD	FAIRHOPE	AL	36532	\$115.40	1/12/2012
1011271-114028472	1006547	109057401	603 BELLANGEE ST	FAIRHOPE	AL	36532	\$127.11	1/12/2012
1002349-103063359	1013568	117089501	207 PINECREST LN	FAIRHOPE	AL	36532	\$75.45	1/12/2012
1012354-116625410	1000009	101104009	P.O. BOX 1191	FAIRHOPE	AL	36533	(\$2.99)	1/12/2012
1006180-109020724	1009631	111053181	19172 FAIRFIELD DR	FAIRHOPE	AL	36532	\$92.64	1/13/2012
1013565-117075800	1003499	103061235	5421 GREENLEAF RD	MOBILE	AL	36693	\$38.90	1/17/2012
1007847-110017341	1009090	110236581	1311 GRENDRIDGE STRATFORD	ATLANTA	GA	30342	\$34.42	1/17/2012
1013239-117040818	1005302	104110267	15591 COUNTY RD 49 #3	SUMMERDALE	AL	36580	\$267.62	1/18/2012
1017148-119000385	1004432	104100370	19095 MEADOW DOVE LN	SILVERHILL	AL	36576	\$43.43	1/18/2012
1009069-110023856	1013516	117126616	198 AUTUMN DR LOT 38	FAIRHOPE	AL	36532	\$818.66	1/19/2012
1013516-117126616	1014977	117130515	473 LEE WOODS RD	SURRENCY	GA	31563	\$447.88	1/19/2012
1021568-121070805	1000175	104125750	229 E 20TH AVE STE 2	GULF SHORES	AL	36542	(\$0.70)	1/20/2012
1006740-110025861	1013525	117079089	198 AUTUMN DR LOT 31	FAIRHOPE	AL	36532	\$328.49	1/23/2012
1005361-104102665	1006537	109056994	PO BOX 2306	GULF SHORES	AL	36542	\$446.91	1/23/2012
1013581-117098744	1009057	110092622	154 APPOMATOX DR	DAPHNE	AL	36526	\$848.94	1/23/2012
1005586-106023673	1007204	110056901	709 JOHNSON AVE	FAIRHOPE	AL	36532	\$999.54	1/24/2012
1017144-119005739	1015755	117659802	20875 LAWRENCE RD	FAIRHOPE	AL	36532	\$134.79	1/24/2012
1012610-116055463	1007642	110025779	102 COURTHOUSE DR #14	FAIRHOPE	AL	36532	\$168.28	1/24/2012
1013679-117125558	1009028	110097477	P.O. BOX 662	FAIRHOPE	AL	36533	\$268.86	1/25/2012
1018067-119254756	1009151	110009578	P.O. BOX 697	DAPHNE	AL	36526	\$326.25	1/25/2012
1013698-117127454	1010871	114006423	371 RIDGEWOOD CIR	FAIRHOPE	AL	36532	\$788.39	1/25/2012
1013802-117125468	1003418	103061722	15149 EDWARD KELLER LN	FAIRHOPE	AL	36532	(\$5.96)	1/26/2012
1015477-117626517	1012561	116191908	22 SIGNAL HILL	SPANISH FORT	AL	36527	\$29.92	1/26/2012
1013235-117040785	1014906	117090502	11265 MCKENZIE RD	FAIRHOPE	AL	36532	\$73.43	1/26/2012
1017230-119000651	1007227	110047969	612 FAIRHOPE AVE APT G	FAIRHOPE	AL	36532	\$152.84	1/27/2012
1007608-110017923	1001250	102045108	26214 POLLARD RD	DAPHNE	AL	36526	(\$11.18)	1/27/2012
1019165-119005541	1012307	116242100	22 LEE CIRCLE	SPANISH FORT	AL	36527	\$31.41	1/27/2012
1006332-109016015	1009929	111067461	806 N GREENO RD LOT 19	FAIRHOPE	AL	36532	\$928.08	1/27/2012
1009757-111036510	1014995	117130196	23180 PEARSON LN	ROBERTSDALE	AL	36567	\$116.35	1/27/2012
1012360-116600515	1018280	119002583	8847 LAKE VIEW DR	FAIRHOPE	AL	36532	\$371.92	1/27/2012
1013234-117045707	1004836	104155695	112 HELTON DR	FOLEY	AL	36535	\$105.11	1/27/2012
1016102-117375483	1013239	117040818	952 KENNY ST	MOBILE	AL	36606	\$13.33	1/30/2012
1014679-117350594	1023275	124200000	1306 CAPTAIN O NEAL DR	DAPHNE	AL	36526	\$135.91	2/1/2012
1017795-119254858	1006601	109065483	23969 GEMSTONE DR	LOXLEY	AL	36551	\$235.40	2/1/2012
1005302-104110267	1006623	109085471	171 NORTSHORE CIR	GULF SHORES	AL	36532	\$98.78	2/1/2012
1014873-117400055	1015467	117780005	144 MONTCLAIR LOOP	DAPHNE	AL	36526	\$636.86	2/2/2012
1013525-117079089	1005593	106027995	1018 54TH ST E	TUSCALOOSA	AL	35405	\$40.79	2/3/2012
1013541-117080163	1010925	114026601	205 NICHOLS AVE	FAIRHOPE	AL	36532	\$470.16	2/3/2012
1009013-110096794	1009951	111078550	726 VOLANTA	FAIRHOPE	AL	36532	\$401.90	2/6/2012
1010987-114013207	1014337	117322505	205 MEMORIAL AVE	FAIRHOPE	AL	36532	\$102.58	2/6/2012
1005341-104152697	1012466	116452870	27927 RILEYWOOD DR	DAPHNE	AL	36527	\$345.45	2/6/2012
1013794-117120250	1002326	103063217	PO BOX 1002	POINT CLEAR	AL	36564	\$66.75	2/7/2012
1000374-113035693	1002548	103054874	1190 SCHNEIDER LN	LK PROVIDENCE	LA	36532	\$91.02	2/7/2012
1013536-117854616	1004596	104155231	21845 MAHAN DR	ROBERTSDALE	AL	36567	\$59.66	2/8/2012
1008540-110012562	1007130	110025660	18 BLUE ISLAND ST	FAIRHOPE	AL	36532	\$822.28	2/9/2012
1006754-110005124	1009934	111078540	806 N GREENO RD #23	FAIRHOPE	AL	36532	\$308.75	2/10/2012
1009148-110092701	1013530	117085692	198 AUTUMN DR LOT 29	FAIRHOPE	AL	36532	\$287.81	2/15/2012
1006765-110005403	1009918	111069856	806 N GREENO RD LOT 7	FAIRHOPE	AL	36532	\$674.73	2/15/2012
1020590-120047948	1007517	110025469	11412 MOCKINGBIRD LN	FAIRHOPE	AL	36532	(\$1.95)	2/15/2012
1009173-110095915	1000442	117078997	6330 CREEKBEND DR	HOUSTON	TX	77096	\$465.55	2/16/2012
1010495-113012025	1016466	117787400	9961 HOLLOWBROOK AVE	FAIRHOPE	AL	36532	\$164.52	2/16/2012
1010470-113023650	1006331	109023705	18540 PATTERSON RD	SILVERHILL	AL	36576	\$134.72	2/20/2012
1011214-114025633	1002125	102036504	S01 UNIVERSITY	CLEVELAND	MS	38732	\$249.13	2/21/2012
1015444-117611261	1009063	110085477	PQ BOX 786	FAIRHOPE	AL	36533	\$293.62	2/21/2012
1013695-117156900	1013226	117040816	9556 COUNTY RD 34 LOT 19	FAIRHOPE	AL	36532	\$67.03	2/21/2012
1023792-125930290	1018650	119002677	136 GRIFFIN DR	FRANKLIN	AL	36444	\$100.00	2/22/2012
1012316-116452303	1006523	109046950	305 YOUNG ST	FAIRHOPE	AL	36532	\$112.84	2/23/2012
1018870-119003183	1006760	110005383	807 MORPHY AVE	FAIRHOPE	AL	36532	\$363.25	2/24/2012
1022998-124526910	1004498	104125745	PO BOX 1346	ROBERTSDALE	AL	36567	\$57.15	2/24/2012
1009119-110096305	1010470	113023650	P.O. BOX 1822	FAIRHOPE	AL	36533	\$367.59	2/27/2012
1012641-116055593	1021056	121023660	P.O. BOX 201	POINT CLEAR	AL	36564	\$249.61	2/27/2012

City of Fairhope

Write off Customer Terminated balances as of 6/01/2021

Customer Info	Property ID	Customer ID	Address 1	City	State	Zip Code	Total Unpaid	Stop Date
1014916-117625459	1009140	110095424	901 GAYFER AVE APT 825	FAIRHOPE	AL	36532	\$492.88	2/27/2012
1005348-104125767	1005774	107125471	111 FELLS AVE	FAIRHOPE	AL	36532	\$1,778.50	2/28/2012
1013745-117458706	1018277	119006505	5075 HAVEN PL APT 307	DUBLIN	CA	94568	(\$1.58)	2/28/2012
1013236-117040931	1015963	117040685	5948 HIGHWAY 157	HAUGHTON	LA	71037	\$41.50	3/1/2012
1003766-103070858	1020976	120068466	577 VALLEYVIEW DR	VALLEY GRANDE	AL	36703	\$209.96	3/1/2012
1006554-109055403	1010746	113038452	100 LAUREL ST	FAIRHOPE	AL	36532	\$288.75	3/2/2012
1014846-117857406	1000482	119256997	4293 ERRESS BLVD	PENSACOLA	FL	32505	\$667.28	3/2/2012
1011599-115266003	1002012	102050954	4318 DOWNTOWNER LP N #E	MOBILE	AL	36609	(\$0.70)	3/2/2012
1011092-114019800	1017424	119256920	PO BOX 364	POINT CLEAR	AL	36564	\$353.80	3/5/2012
1009152-110009534	1002142	113040637	54 N CHURCH ST APT 21	FAIRHOPE	AL	36532	\$2,926.20	3/5/2012
1000877-101059528	1018867	119003768	19720 THOMPSON HALL RD	FAIRHOPE	AL	36532	\$125.59	3/5/2012
1012305-116241610	1005300	104125619	P.O. BOX 365	SUMMERDALE	AL	36580	\$53.35	3/5/2012
1003384-103060416	1013692	117458805	201 SPRINGRUN APT 41	FAIRHOPE	AL	36532	\$163.11	3/5/2012
1013623-117081138	1006922	110019062	411 MYRTLE ST	FAIRHOPE	AL	36532	\$556.23	3/5/2012
1007731-110018119	1007360	110236586	601 WEINACKER AVE	MOBILE	AL	36604	\$105.78	3/6/2012
1007966-110015900	1023927	125196006	27670 HWY 98 #51	DAPHNE	AL	36526	\$29.94	3/6/2012
1005360-104106635	1011677	115326908	30941 MILL LN #G125	SPANISH FT	AL	36527	\$113.15	3/6/2012
1007801-110017865	1013223	117040264	20568 EAST SILVERHILL RD	ROBERTSDALE	AL	36567	\$28.07	3/7/2012
1008124-110023719	1018982	119199968	9625 TWIN BEECH RD #3	FAIRHOPE	AL	36532	\$23.52	3/8/2012
1006145-109016789	1006347	109020834	7720 THOMAS RD APT 1601	MOBILE	AL	36695	\$40.56	3/8/2012
1006630-109071003	1020707	120057001	101 HOMESTEAD APT 36	FAIRHOPE	AL	36532	(\$0.46)	3/9/2012
1016943-118014503	1017089	119458901	PO BOX 1141	FAIRHOPE	AL	36532	\$601.18	3/12/2012
1004808-104125623	1001679	102050536	9244 HWY 98	FAIRHOPE	AL	36532	\$332.40	3/12/2012
1002064-102050905	1017842	119256948	7684 TWIN BEECH RD #203	FAIRHOPE	AL	36532	\$196.13	3/13/2012
1013317-117058594	1009095	110096354	224 TRAY CIRCLE	DAPHNE	AL	36526	\$248.36	3/13/2012
1008603-110017348	1016336	117785504	595 LAKESIDE DR	CENTRE	AL	35960	\$23.78	3/13/2012
1004692-104102111	1006250	109027451	674 MIDDLE ST	FAIRHOPE	AL	36532	\$370.29	3/14/2012
1004973-104106678	1009127	110085003	901 GAYFER AVE APT 722	FAIRHOPE	AL	36532	\$107.77	3/14/2012
1014365-117326605	1001752	102046507	23337-B COUNTY RD 85	ROBERTSDALE	AL	36567	\$50.78	3/15/2012
1011562-115252532	1009173	110095811	901 GAYFER AVE APT 1025	FAIRHOPE	AL	36532	\$469.87	3/15/2012
1002325-103066538	1009204	110095805	901 GAYFER AVE APT 1324	FAIRHOPE	AL	36532	\$664.35	3/15/2012
1006248-109026635	1010792	113056900	P.O. BOX 828	FAIRHOPE	AL	36533	\$327.87	3/15/2012
1006248-109026635	1015015	117236580	575 WEDGEWOOD DR	DAPHNE	AL	36526	\$144.53	3/15/2012
1013528-117085487	1013481	117066284	578 AZALEA RD STE 115	MOBILE	AL	36609	\$2.42	3/16/2012
1000862-101046988	1009922	111258600	806 N GREENO RD LOT 12	FAIRHOPE	AL	36532	\$579.68	3/16/2012
1013559-117126604	1009690	111026591	19471 E RIVER RD N	SILVERHILL	AL	36576	(\$9.08)	3/19/2012
1009035-110045919	1005207	104125615	604 E ORANGE AVE	FOLEY	AL	36535	\$79.15	3/19/2012
1001752-102046507	1005301	104116580	15591 COUNTY RD 49 #4	SUMMERDALE	AL	36580	\$73.31	3/19/2012
1004115-103025401	1007600	110125490	101 HOMESTEAD APT 36	FAIRHOPE	AL	36532	\$10.57	3/19/2012
1000156-103037509	1003397	103065346	9997 COUNTY RD 24	FAIRHOPE	AL	36532	\$197.51	3/21/2012
1018204-119200508	1009702	111037606	11533 MOCKINGBIRD LANE	FAIRHOPE	AL	36532	\$617.86	3/21/2012
1005582-106023672	1023737	125901255	370 RIDGEWOOD DR	DAPHNE	AL	36526	\$34.84	3/21/2012
1006853-110023877	1009380	111014332	423 MILLER AVE	FAIRHOPE	AL	36532	\$117.43	3/22/2012
1009173-110095811	1008040	110026582	7252 KIRKMAN LN	FAIRHOPE	AL	36532	\$189.30	3/22/2012
1013280-117045885	1013423	117066274	123 CASA CT	PAVERNIER	FL	33070	\$11.79	3/23/2012
1001367-102040500	1000890	101059611	650 GAYFER AVE	FAIRHOPE	AL	36532	\$164.81	3/23/2012
1008111-110017830	1007758	110452870	273 AZALEA RD STE 2-516	MOBILE	AL	36609	\$790.11	3/26/2012
1006498-109031501	1013940	117180062	7 BURLINGTON DR	FAIRHOPE	AL	36532	\$631.58	3/27/2012
1013498-117067483	1007029	110018415	252 N INGLESIDE	FAIRHOPE	AL	36532	\$382.94	3/29/2012
1000369-113031434	1017694	119256946	19075 BELL RD	FAIRHOPE	AL	36532	\$228.84	3/30/2012
1009366-111237455	1022172	124000453	PO BOX 1062	MONTROSE	AL	36559	\$148.76	3/30/2012
1003503-103065379	1022174	124000454	PO BOX 1062	MONTROSE	AL	36559	\$56.80	3/30/2012
1002223-102028690	1004165	104000624	12 WESTWOOD ST	MOBILE	AL	36606	\$86.02	4/2/2012
1014418-117305385	1008136	110016911	P.O. BOX 70555	KNOXVILLE	TN	37938	\$592.53	4/2/2012
1006802-110010407	1015485	117625452	21310 ST HWY 181 #22	FAIRHOPE	AL	36532	\$55.63	4/2/2012
1006873-110028467	1010176	111055841	114 WILLOW LAKE DR	FAIRHOPE	AL	36532	(\$15.94)	4/2/2012
1012001-115312539	1017553	119000792	17050 S SECTION ST #8	FAIRHOPE	AL	36532	\$16.38	4/3/2012
1017089-119458901	1015194	117652491	2200 EAST BAY DR	DAPHNE	AL	36526	(\$5.96)	4/3/2012
1010615-113034580	1014817	117402600	12278 A GRANTHAM RD	FOLEY	AL	36535	\$92.78	4/3/2012
1002326-103063217	1009146	110096670	901 GAYFER AVE APT 824	FAIRHOPE	AL	36532	\$165.13	4/3/2012
1009941-111076424	1000483	119003762	18653 TWIN BEECH RD	FAIRHOPE	AL	36532	\$111.96	4/3/2012
1013563-117086544	1002083	102050824	10720 COUNTY RD 24	FAIRHOPE	AL	36532	\$8.78	4/5/2012

City of Fairhope

Write off Customer Terminated balances as of 6/01/2021

Customer Info	Property ID	Customer ID	Address 1	City	State	Zip Code	Total Unpaid	Stop Date
1016218-117610835	1018692	119002636	981 WHITTIER ST	FAIRHOPE	AL	36532	\$13.36	4/9/2012
1002685-103626508	1012339	116070504	7359 HIGHPOINTE PLACE E	SPANISH FT	AL	36527	\$15.57	4/9/2012
1003497-103062816	1007887	110254160	P.O. BOX 334	FAIRHOPE	AL	36533	\$6.72	4/10/2012
1005334-104106008	1011599	115266003	22970 E CHICAGO ST	ROBERTSDALE	AL	36567	\$0.37	4/10/2012
1018818-119254761	1003470	103061475	3293 ABERDEEN RD	VERNON	AL	35592	\$132.05	4/10/2012
1012651-116190529	1013528	117085487	198 AUTUMN DR LOT 51	FAIRHOPE	AL	36532	\$1,076.95	4/12/2012
1021529-121085472	1006793	110012513	805 MICHIGAN AVE	FAIRHOPE	AL	36532	\$581.03	4/12/2012
1012016-115362004	1008070	110025802	105 LAWSON RD	DAPHNE	AL	36526	\$212.87	4/12/2012
1005349-104125721	1009073	110452131	15544 PADDINGTON DR	FOLEY	AL	36535	\$319.96	4/13/2012
1007130-110002566	1013929	117104503	114 SPRING PARK DR	FAIRHOPE	AL	36532	\$16.51	4/13/2012
1012459-116110204	1011253	114028456	213 PIER	FAIRHOPE	AL	36532	\$513.81	4/17/2012
1009312-111025441	1000420	117625465	20837 US HWY 90 LOT 6	ROBERTSDALE	AL	36567	\$47.36	4/18/2012
1003486-103066656	1013553	117079120	1066 S MAGNOLIA ST	LOXLEY	AL	36551	\$604.84	4/19/2012
1007205-110047552	1006475	109025742	394 S INGLESIDE ST	FAIRHOPE	AL	36532	\$669.98	4/20/2012
1001247-102046234	1015750	117611053	20949 LAWRENCE RD #3	FAIRHOPE	AL	36532	\$79.23	4/23/2012
1022714-124003487	1009924	111075492	806 N GREENO RD LOT 14	FAIRHOPE	AL	36532	\$235.62	4/23/2012
1016103-117452002	1008540	110012547	21081 BISHOP RD #3	FAIRHOPE	AL	36532	\$401.21	4/23/2012
1013566-117085495	1012213	116011205	6504 GRANADA DR	SATSUMA	AL	36572	\$62.70	4/26/2012
1003770-103063292	1006181	109056998	550 MIDDLE ST	FAIRHOPE	AL	36532	\$341.49	4/27/2012
1017826-119266503	1015896	117046988	109 KEMPER LN	FAIRHOPE	AL	36532	\$56.52	4/27/2012
1009340-111026617	1014883	117598013	6836 CONFORTI CT	FRANKLIN	WI	53132	\$69.43	4/30/2012
1015477-117626513	1005583	106023668	107 S MOBILE ST APT 2	FAIRHOPE	AL	36532	\$1.29	4/30/2012
1013573-117095484	1007949	110025653	14 MCCUE CIRCLE	FAIRHOPE	AL	36532	\$182.54	4/30/2012
1005348-104125775	1015341	117854784	23051 WILSON RD	LOXLEY	AL	36551	\$40.95	5/1/2012
1017764-119257132	1009099	110096687	PO BOX 162	CARROLLTON	AL	35447	\$275.00	5/1/2012
1013463-117652156	1009491	111026521	418 VOLANTA	FAIRHOPE	AL	36532	\$564.34	5/1/2012
1019285-119004820	1022155	124001838	23210 U.S. HWY 98 STE A3	FAIRHOPE	AL	36532	\$732.18	5/1/2012
1016441-117785693	1016274	117610935	2155 BENTON BLVD	POOLER	GA	31322	\$24.42	5/2/2012
1009158-110092790	1017006	118080427	29960 SAINT SIMON ST	DAPHNE	AL	36526	\$123.00	5/2/2012
1007404-110011568	1023226	124125478	30941 MILL LN	DAPHNE	AL	36526	(\$9.08)	5/2/2012
1017699-119003709	1015093	117130559	804 CRYSTAL WELLS CT S	FAIRHOPE	AL	36532	\$46.63	5/2/2012
1006315-109025640	1009921	111075493	806 N GREENO RD LOT 11	FAIRHOPE	AL	36532	\$597.47	5/2/2012
1007057-110018105	1007218	110048520	656 FAIRHOPE AVE	FAIRHOPE	AL	36532	\$354.99	5/3/2012
1015542-117610947	1008639	110452133	P.O. BOX 581	FAIRHOPE	AL	36533	\$191.92	5/7/2012
1013597-117082560	1015038	117137450	500 WESTCHASE CT N	FAIRHOPE	AL	36532	\$320.63	5/7/2012
1009951-111078550	1018858	119003232	19784 CARDINAL DR LOT 36	FAIRHOPE	AL	36532	\$152.37	5/8/2012
1009000-110958420	1004279	104006758	210 FAIRHOPE AVE #C	FAIRHOPE	AL	36532	\$526.26	5/9/2012
1015750-117611053	1005022	104106582	PO BOX 212	ELBERTA	AL	36530	\$17.54	5/15/2012
1003472-103075422	1017687	119000908	18957 BRACEY LN	FAIRHOPE	AL	36532	\$91.92	5/15/2012
1003077-103075250	1011612	115285400	7150 KNOLLWOOD DR	MOBILE	AL	36609	\$21.16	5/15/2012
1016274-117610935	1001590	102049994	7154 US HWY 98	FAIRHOPE	AL	36532	\$166.58	5/16/2012
1005393-105035827	1001686	102050952	13387 CHRIS HIRES RD	FAIRHOPE	AL	36532	\$83.70	5/16/2012
1004165-104000624	1004272	104521460	208 FAIRHOPE AVE APT 14	FAIRHOPE	AL	36532	\$632.62	5/17/2012
1003493-103060990	1006191	109021504	PO BOX 1936	FAIRHOPE	AL	36533	\$159.88	5/17/2012
1014692-117350654	1020972	120069852	679 E MICHIGAN AVE	FOLEY	AL	36535	\$7.37	5/18/2012
1011271-114028467	1000369	113031434	155 ORANGE AVE	FAIRHOPE	AL	36532	\$1,520.49	5/21/2012
1015006-117095219	1006876	110025685	490 BUCKINGHAM CR	MARIETTA	GA	30066	\$0.60	5/21/2012
1019186-119005045	1006601	109068501	53 BROWN ST	FAIRHOPE	AL	36532	\$549.42	5/21/2012
1002814-103060145	1015106	117782346	2521 HILLCREST RD STE A	MOBILE	AL	36606	\$50.06	5/22/2012
1009180-110056567	1020814	120070439	18950 CHEF MENTEUR HWY	NEW ORLEANS	LA	70129	\$118.43	5/23/2012
1004247-104251620	1008641	110125493	8281 GAYFER RD EXT 4-A	FAIRHOPE	AL	36532	\$193.21	5/23/2012
1018298-119061901	1007225	110058742	PO BOX 212	ATLANTIC	NC	28511	\$268.78	5/24/2012
1005336-104106689	1024333	125930176	28708 BAY BRANCH DR	DAPHNE	AL	36526	(\$0.48)	5/24/2012
1002125-102036504	1003672	103066521	357 MERSHON ST	FAIRHOPE	AL	36532	\$398.74	5/25/2012
1014616-117327406	1009483	111026604	513 VOLANTA AVE	FAIRHOPE	AL	36532	\$333.13	5/30/2012
1015696-117611132	1000553	122050343	18653 TWIN BEECH	FAIRHOPE	AL	36532	\$69.02	5/30/2012
1006246-109026623	1009210	110095819	8330 CAROUSEL CT	DAPHNE	AL	36526	\$361.30	5/31/2012
1017180-119257058	1008673	110254693	3441 WHITE ROSE WAY	ENCINO	CA	91436	\$159.98	5/31/2012
1013800-117458902	1005019	104126604	14363 BROOK HOLLOW RD	SUMMERDALE	AL	36580	\$98.57	6/1/2012
1008538-110025541	1021682	122052362	P.O. BOX 169	POINT CLEAR	AL	36564	\$417.93	6/1/2012
1003397-103065346	1000053	102049980	9650 US HIGHWAY 98 #14	FAIRHOPE	AL	36532	\$78.93	6/1/2012
1007102-110036527	1001225	102040474	11699 ARLINGTON BLVD	SPANISH FORT	AL	36527	\$114.65	6/1/2012

City of Fairhope

Write off Customer Terminated balances as of 6/01/2021

Customer Info	Property ID	Customer ID	Address 1	City	State	Zip Code	Total Unpaid	Stop Date
1017811-119256929	1016761	117047251	923 HEIFER HORN TRACE	COLUMBUS	GA	31904	\$131.27	6/1/2012
1005113-104125552	1006310	109024077	7373 KIRKMAN LANE	FAIRHOPE	AL	36532	\$40.14	6/4/2012
1013228-117045945	1008645	110023793	8281 GAYFER AVE UNIT A	FAIRHOPE	AL	36532	\$70.88	6/4/2012
1012420-116632541	1013516	117126617	198 AUTUMN DR LOT 39	FAIRHOPE	AL	36532	\$145.98	6/4/2012
1005991-109025463	1018818	119254751	13285 CHARLIE PRIDE HWY	VANCE	MS	38964	\$305.68	6/5/2012
1010125-111025468	1011070	114026586	P.O. BOX 1825	FAIRHOPE	AL	36533	\$247.09	6/6/2012
1009674-111046982	1008912	110069854	918 EDWARDS AVE	FAIRHOPE	AL	36532	\$960.24	6/7/2012
1013756-117125485	1013498	117067483	12284 BARNES RD	BAY MINETTE	AL	36507	\$23.52	6/8/2012
1018335-119002374	1009143	110095781	901 GAYFER AVE APT 826	FAIRHOPE	AL	36532	\$7.25	6/8/2012
1005175-104107837	1014508	117305329	336 KNOLLWOOD AVE	FAIRHOPE	AL	36532	\$221.41	6/13/2012
1006310-109024077	1006193	109021606	572 FAIRLAND AVE	FAIRHOPE	AL	36532	\$90.61	6/14/2012
1001249-102045114	1008251	110025440	12142 TWIN OAKS DR	MAGNILOA SPGS	AL	36555	\$46.91	6/15/2012
1017164-119564883	1018595	119255729	216 RIDGEWOOD DR	DAPHNE	AL	36526	\$511.64	6/18/2012
1019529-119004611	1013529	117079119	8013 KIMBERLIN DR S	MOBILE	AL	36695	\$209.66	6/18/2012
1005209-104125506	1016425	117785503	27 THORNCROFT AVE	BATTLECREEK	MI	49017	\$56.45	6/19/2012
1019327-119005053	1005066	104106848	408 W FIG AVE	FOLEY	AL	36535	\$55.61	6/19/2012
1015038-117137453	1017721	119254879	18960 MALONE RD	FAIRHOPE	AL	36532	\$80.86	6/20/2012
1015281-117856922	1002817	103065341	16940 LEA CIRCLE	FAIRHOPE	AL	36532	\$65.50	6/22/2012
1013244-117040926	1013940	117180064	7 BURLINGTON DR	FAIRHOPE	AL	36532	\$121.91	6/22/2012
1009617-111045882	1017680	119001015	7308 TWIN BEECH RD	FAIRHOPE	AL	36532	\$202.82	6/25/2012
1017067-118103116	1000399	115291550	PO BOX 2341	DAPHNE	AL	36526	\$61.86	6/25/2012
1001714-102042158	1020953	120090610	8740 LEA BROOK ST	FAIRHOPE	AL	36532	\$162.01	6/25/2012
1004686-104101141	1018978	119258914	9625 TWIN BEECH RD #1	FAIRHOPE	AL	36532	\$67.74	6/25/2012
1002083-102050824	1000836	101055699	367 S SCHOOL ST	FAIRHOPE	AL	36532	\$292.71	6/25/2012
1003323-103063228	1021968	123152303	102 WINDSOR DR	DAPHNE	AL	36526	\$102.17	6/25/2012
1006537-109057007	1017190	119000526	PO BOX 755	FAIRHOPE	AL	36533	\$121.18	6/25/2012
1001746-102042369	1011643	115291451	8245 SPANISH FORT BLVD	SPANISH FORT	AL	36527	\$4.20	6/25/2012
1006537-109056997	1015480	117610748	21400 COUNTY RD 27 LOT 2	FAIRHOPE	AL	36532	\$192.10	6/25/2012
1013285-117056982	1018980	119125401	9625 TWIN BEECH RD #2	FAIRHOPE	AL	36532	\$71.18	6/25/2012
1019353-119258977	1014773	117378450	12150 BALDWIN LANE	FAIRHOPE	AL	36532	\$62.08	6/25/2012
1007806-110017407	1013587	117125565	200 AUTUMN DR 8D	FAIRHOPE	AL	36532	\$980.60	6/25/2012
1005614-107125407	1021022	121004642	17782 LITTLE ROCK RD	FOLEY	AL	36535	\$206.24	6/25/2012
1007819-110017943	1001247	102046234	11207 COUNTY RD 1	FAIRHOPE	AL	36532	\$23.52	6/26/2012
1007801-110017377	1009257	111056985	553 JAN DR	FAIRHOPE	AL	36532	\$218.71	6/26/2012
1013244-117040870	1000408	115362000	10171 PAPAGEORGE ST #8	DAPHNE	AL	36526	\$13.97	6/26/2012
1004690-104104423	1014616	117327402	10825 COUNTY RD 48	FAIRHOPE	AL	36532	\$53.48	6/27/2012
1018898-119006082	1000558	123004005	602 VALTA	MOBILE	AL	36609	\$50.50	6/27/2012
1004277-104526990	1013745	117458706	P O BOX 820	DAPHNE	AL	36526	\$185.37	6/28/2012
1006856-110452303	1008603	110017348	21 S ROLLING OAKS	FAIRHOPE	AL	36532	\$64.00	6/29/2012
1016343-117785645	1004352	104120029	5012 N HOLLY ST	LOXLEY	AL	36551	\$31.49	6/29/2012
1007296-110236592	1021580	121067506	6609 AUTUMN RIDGE DR	MOBILE	AL	36695	\$14.04	6/29/2012
1011420-115137763	1009929	111067463	PO BOX 268	FAIRHOPE	AL	36533	\$155.88	6/29/2012
1015472-117610453	1006084	109016571	10845 FAYTH RD #27	COALING	AL	35453	\$91.18	6/29/2012
1005265-104110469	1004433	104155600	19138 MEADOW DOVE LN #19	SILVERHILL	AL	36576	\$150.07	7/2/2012
1017201-119255764	1008941	110095834	10720 COUNTY RD 32	FAIRHOPE	AL	36532	\$693.39	7/2/2012
1017424-119256920	1011250	114023676	358 PECAN AVE	FAIRHOPE	AL	36532	\$128.29	7/2/2012
1004463-104102703	1017058	118104001	112 SARA AVE E	SPANISH FORT	AL	36527	\$66.00	7/3/2012
1009410-111013345	1008901	110067605	426 PATLYNN DR	FAIRHOPE	AL	36532	\$100.56	7/3/2012
1008641-110125507	1008091	110090373	8642 BROOK LN	FAIRHOPE	AL	36532	\$167.64	7/5/2012
1009063-110085477	1009256	111006913	555 JAN DR	FAIRHOPE	AL	36532	\$541.00	7/5/2012
1006229-109053008	1003792	103061065	17105 OYSTER BAY RD	GULF SHORES	AL	36542	\$23.04	7/6/2012
1018631-119569836	1020952	120090631	6 MOLOKIA LANE	FAIRHOPE	AL	36532	\$75.70	7/6/2012
1005364-104100459	1017164	119564883	PO BOX 1573	FAIRHOPE	AL	36533	\$189.08	7/9/2012
1003496-103015960	1015449	117655233	10196 MISSION TRACE	FAIRHOPE	AL	36532	\$53.35	7/9/2012
1002817-103065386	1023769	125901045	9614 NOTTINGHAM CT	DAPHNE	AL	36526	\$16.62	7/9/2012
1015752-117626593	1006530	109050055	605 MORPHY AVE	FAIRHOPE	AL	36532	\$35.66	7/12/2012
1014847-117402380	1013777	117125561	129 EAST PERSHING	MOBILE	AL	36610	\$473.81	7/12/2012
1002344-103063318	1008924	110090374	155 ORANGE AVE	FAIRHOPE	AL	36532	\$1,973.67	7/16/2012
1003448-103063133	1007130	110002566	P.O. BOX 1243	FAIRHOPE	AL	36533	\$1,113.53	7/17/2012
1006248-109026639	1017001	118066590	13823 WHITE RD	SILVERHILL	AL	36576	\$66.45	7/18/2012
1009210-110095819	1019246	119564817	308 LAFAYETTE POINT CIR	CLARKSVILLE	TN	37042	\$38.26	7/20/2012
1009158-110092783	1014286	117782309	17180 SE 78TH CROWFIELD	THE VILLAGES	FL	32162	\$0.01	7/23/2012

City of Fairhope

Write off Customer Terminated balances as of 6/01/2021

Customer Info	Property ID	Customer ID	Address 1	City	State	Zip Code	Total Unpaid	Stop Date
1008380-110023941	1013235	117040785	263 NORTHGATE DR	LOXLEY	AL	36551	\$259.31	7/24/2012
1009924-111075492	1009091	110096675	PO BOX 1821	FAIRHOPE	AL	36533	\$108.42	7/24/2012
1005356-104100198	1015571	117611145	6824 CEDAR RUN	MONTROSE	AL	36559	\$93.05	7/24/2012
1013272-117040786	1013918	117104079	114 REILLY CIR	FAIRHOPE	AL	36532	\$1,428.52	7/24/2012
1005964-108026607	1012641	116055593	4 YANKEE TROVE	SPANISH FT	AL	36527	(\$7.67)	7/25/2012
1003976-103061568	1018529	119574808	19091 BOOTHE RD	FAIRHOPE	AL	36532	\$313.97	7/25/2012
1001687-102050278	1004879	104125739	363 WASHINGTON BLVD	LAKE CLASSIC	FL	33852	\$185.55	7/26/2012
1018863-119254141	1000475	117376002	112 PAR CIR	FAIRHOPE	AL	36532	(\$3.73)	7/26/2012
1021721-122050147	1008667	110023603	101 HOYLE AVE	FAIRHOPE	AL	36532	\$911.96	7/26/2012
1007529-110015628	1013542	117079502	198 AUTUMN DR LOT 53	FAIRHOPE	AL	36532	\$1,077.80	7/26/2012
1001427-102040494	1013525	117079122	198 AUTUMN DR LOT 31	FAIRHOPE	AL	36532	\$262.41	7/30/2012
1000399-115291550	1015447	117625485	10208 MISSION TRACE #16	FAIRHOPE	AL	36532	\$74.62	7/31/2012
1018653-119578403	1010868	114006507	309 19TH AVE	BELMAR	NJ	07719	\$553.12	7/31/2012
1013223-117040872	1013375	117059965	PO BOX 2052	DAPHNE	AL	36526	\$351.86	7/31/2012
1007102-110036529	1009137	110096551	500 JACKSON ST #1407	DAPHNE	AL	36526	\$140.34	8/1/2012
1005492-105005559	1014324	117326542	P.O. BOX 987	FAIRHOPE	AL	36533	\$161.68	8/2/2012
1009184-110098482	1001725	102042056	6571 HARNESWOOD CT	MASON	OH	45040	\$53.48	8/2/2012
1001741-102042316	1000217	107125402	7590 AVERY LN	DAPHNE	AL	36526	\$226.51	8/2/2012
1007204-110056901	1015052	117130550	612 WESTCHASE CT S	FAIRHOPE	AL	36532	\$599.33	8/2/2012
1024340-125930094	1015750	117611150	29883 SAINT SIMON ST	DAPHNE	AL	36526	\$26.09	8/2/2012
1003756-103456980	1004978	104107856	12977 CHEELEY'S CT	SUMMERDALE	AL	36580	\$68.96	8/2/2012
1018545-119257039	1014916	117625451	12731 CLAY CITY RD #B	FAIRHOPE	AL	36532	\$208.37	8/6/2012
1009204-110095806	1003524	103065130	PO BOX 772	FAIRHOPE	AL	36533	(\$14.04)	8/6/2012
1009922-111258602	1008981	110098756	21592 STATE HWY 181 #A	FAIRHOPE	AL	36532	\$714.33	8/6/2012
1005373-104125909	1009481	111025490	PO BOX 1974	FAIRHOPE	AL	36533	\$144.67	8/6/2012
1017833-119568719	1004219	104012500	PO BOX 173	FAIRHOPE	AL	36533	\$232.61	8/7/2012
1013282-117040261	1004836	104155697	PO BOX 426	SUMMERDALE	AL	36580	\$81.27	8/7/2012
1014967-117130598	1006099	109016582	308 TRINITY CT	PERRYSBURG	OH	43551	\$500.41	8/9/2012
1006068-109021375	1015814	117652485	645 GULF SHORES PKWY	GULF SHORES	AL	36542	\$50.06	8/9/2012
1007846-110017395	1003448	103063133	15166 COUNTY RD 13	FAIRHOPE	AL	36532	\$77.55	8/10/2012
1015647-117254726	1003174	103061355	10255 COUNTY RD 32 LOT 7	FAIRHOPE	AL	36532	\$114.84	8/10/2012
1022002-123159604	1005265	104110469	183 RAINBOW DR #8370	LIVINGSTON	TX	77399	(\$6.52)	8/13/2012
1021254-121085477	1003959	103062806	16989 FERRY RD	FAIRHOPE	AL	36532	\$20.00	8/13/2012
1017694-119001341	1013607	117081092	13 COTTAGE DRIVE	FAIRHOPE	AL	36532	\$113.92	8/13/2012
1014836-117402390	1003759	103066561	12144 MEADOW RD LOT 12	FAIRHOPE	AL	36532	\$32.60	8/13/2012
1013222-117040886	1006536	109057484	PO BOX 308	FAIRHOPE	AL	36533	\$67.00	8/14/2012
1019132-119257172	1005990	109002035	49 S SCHOOL ST	FAIRHOPE	AL	36532	\$413.16	8/14/2012
1022875-124001427	1021697	122058960	20489 HWY 181	FAIRHOPE	AL	36532	(\$2.11)	8/14/2012
1015359-117256932	1000540	122056405	7336 SALUDA BLVD	SP FORT	AL	36527	\$226.46	8/15/2012
1013791-117185904	1023904	125930179	11725 PATRICK LANE	SPANISH FORT	AL	36527	(\$0.19)	8/16/2012
1009491-111026548	1023467	124002823	P.O. BOX 2750	DAPHNE	AL	36526	(\$0.55)	8/16/2012
1013548-117079082	1017774	119254636	15110 W 143RD TER	OLATHE	KS	66062	\$203.17	8/17/2012
1009925-111065333	1015469	117610683	21400 STATE HWY 181 LOT 3	FAIRHOPE	AL	36532	\$12.62	8/17/2012
1014508-117305329	1000858	101052363	4282 ROBERT ST	ZACHARY	LA	70791	\$351.24	8/20/2012
1005838-108025691	1003769	103061292	304 BAYOU AVE	SATSUMA	AL	36572	\$20.00	8/20/2012
1013223-117040855	1017026	118100204	4430 COUNTY RD 10	FRISCO CITY	AL	36445	\$8.92	8/20/2012
1013768-117120751	1005588	106029601	30653 CARRIBBEAN BLVD#C	SPANISH FORT	AL	03657	\$299.90	8/23/2012
1011391-115137850	1016441	117785693	30173 OSPREY LN	ROBERTSDALE	AL	36567	\$75.62	8/24/2012
1017910-119235602	1004266	104126596	208 FAIRHOPE AVE #17	FAIRHOPE	AL	36532	\$300.94	8/24/2012
1004352-104120029	1006839	110012702	35108 SPRING RD S #A	STAPLETON	AL	36578	\$906.44	8/27/2012
1004596-104155231	1006861	110254361	PO BOX 1628	ROBERTSDALE	AL	36567	\$336.20	8/27/2012
1006793-110012513	1006617	109059728	560 BELLANGEE AVE	FAIRHOPE	AL	36532	\$444.65	8/27/2012
1018087-119574810	1006825	110053823	6061 COLONIAL PKWY #7301	GULF SHORES	AL	36542	\$164.43	8/27/2012
1017601-119001722	1001677	102041167	PO BOX 2425	DAPHNE	AL	36526	\$44.47	8/28/2012
1003415-103061692	1002329	103066530	316 LEE ST	BAY MINETTE	AL	36507	\$129.05	8/28/2012
1014780-117425695	1006330	109425600	19238 WILSON DR	FAIRHOPE	AL	36532	\$211.27	8/29/2012
1013481-117066284	1001162	101061025	20294 THOMPSON HALL RD	FAIRHOPE	AL	36532	\$476.18	8/29/2012
1013239-117040871	1014196	117855078	PO BOX 22551	SAVANAH	GA	31403	\$98.60	8/30/2012
1014895-117601015	1004705	104101306	12418 JOHN ARTHUR DR	FOLEY	AL	36535	(\$1.63)	8/30/2012
1009912-111066585	1013659	117452806	201 SPRINGRUN APT 21	FAIRHOPE	AL	36532	\$167.30	8/31/2012
1005587-106021126	1013755	117128549	199 SPRINGRUN DR APT 120	FAIRHOPE	AL	36532	\$407.57	9/4/2012
1013233-117040884	1013582	117090097	3800 COLLEGE BLUFF	OLIVE BRANCH	MS	38654	\$222.53	9/4/2012

City of Fairhope

Write off Customer Terminated balances as of 6/01/2021

Customer Info	Property ID	Customer ID	Address 1	City	State	Zip Code	Total Unpaid	Stop Date
1023904-125930179	1021612	122006003	1545 GULFSHORES PKWY #298	GULF SHORES	AL	36542	\$272.53	9/4/2012
1004843-104105880	1018472	119856901	8275 DINCENT RD	DENIM SPRINGS	LA	70726	\$21.80	9/4/2012
1000533-121079500	1018298	119061901	P.O. BOX 654	GRAND BAY	AL	36541	(\$39.02)	9/5/2012
1021991-123156983	1009919	111037920	105 MEADOWWOOD LP	DAPHNE	AL	36526	\$399.21	9/5/2012
1006537-109057008	1008137	110025530	3893 EMERILLE DR	FOLEY	AL	36535	\$751.99	9/5/2012
1003496-103015962	1017783	119257083	22975 PALMER ST	ROBERTSDALE	AL	36567	\$41.50	9/5/2012
1013789-117325608	1013057	116500239	9385 TIMBERCREEK BLVD	SPANISH FT	AL	36527	\$55.07	9/6/2012
1008970-110023731	1015447	117625505	10208 MISSION TRACE #16	FAIRHOPE	AL	36532	\$31.35	9/6/2012
1011518-115254601	1017747	119855600	PO BOX 1965	FAIRHOPE	AL	36533	\$37.53	9/7/2012
1019351-119255466	1016139	117378000	112 PAR CIRCLE	FAIRHOPE	AL	36532	(\$1.19)	9/10/2012
1009104-110125525	1007231	110052700	612 FAIRHOPE AVE APT L	FAIRHOPE	AL	36532	\$290.25	9/10/2012
1018858-119003232	1013574	117090100	200 AUTUMN DR #2C	FAIRHOPE	AL	36532	\$1,030.61	9/12/2012
1008570-110014701	1014990	117136528	P O BOX 98	FAIRHOPE	AL	36533	\$304.02	9/14/2012
1009394-111013546	1008182	110025654	20872 NOBLEMAN DR	FAIRHOPE	AL	36532	\$199.53	9/14/2012
1004329-104100514	1014952	117137801	14631 RIDGE RD	SUMMERDALE	AL	36580	\$345.05	9/17/2012
1020044-119826954	1000919	101062504	350 GASTON AVE	FAIRHOPE	AL	36532	\$851.52	9/18/2012
1022369-124152600	1008004	110025646	14397 HWY 104	SILVERHILL	AL	36576	\$581.96	9/18/2012
1000971-101055401	1013234	117045702	PO BOX 786	FAIRHOPE	AL	36533	\$104.64	9/18/2012
1005362-104106637	1013617	117080150	6 COTTAGE DR	FAIRHOPE	AL	36532	\$287.33	9/18/2012
1007218-110048520	1004982	104106392	23350 CO RD 65 #8	ROBERTSDALE	AL	36567	\$53.00	9/18/2012
1013321-117058569	1007404	110011568	906 MORPHY AVE	FAIRHOPE	AL	36532	\$813.82	9/19/2012
1009192-110095822	1005206	104107960	14300 COUNTY RD 28 #A	SUMMERDALE	AL	36580	\$8.78	9/19/2012
1017804-119259630	1006503	109027600	1806 KING CHAPEL #17	PERRY	GA	31069	\$302.88	9/19/2012
1013553-117079131	1013722	119004774	201 SPRINGRUN APT 35	FAIRHOPE	AL	36532	\$323.98	9/19/2012
1002160-102052370	1006878	110015144	PO BOX 1132	POINT CLEAR	AL	36564	\$251.24	9/20/2012
1009295-111006228	1002685	103626508	9395 PEMBROOK LOOP	FAIRHOPE	AL	36532	\$48.03	9/21/2012
1007760-110452881	1007102	110036521	16 BURLINGTON DR	FAIRHOPE	AL	36532	\$1,014.33	9/21/2012
1001754-102045624	1013846	117105691	PO BOX 8	ROCKFORD	AL	35136	\$31.09	9/24/2012
1009330-111026553	1007222	110025809	612 FAIRHOPE AVE #C	FAIRHOPE	AL	36532	\$197.80	9/24/2012
1017993-119003980	1013947	117189531	20 BURLINGTON	FAIRHOPE	AL	36532	\$544.48	9/24/2012
1013556-117085706	1009099	110096711	901 GAYFER AVE APT 615	FAIRHOPE	AL	36532	\$583.84	9/24/2012
1013525-117079122	1009128	110095794	901 GAYFER AVE #717	FAIRHOPE	AL	36532	\$763.52	9/24/2012
1009207-110096671	1013280	117045885	953 LEE RD 207 LOT1	PHEONIX CITY	AL	36870	(\$1.18)	9/25/2012
1007551-110021367	1021529	121085472	12834 COUNTY RD 1	FAIRHOPE	AL	36532	\$59.97	9/25/2012
1004339-104152808	1014918	117125551	12731 CLAY CITY RD #A	FAIRHOPE	AL	36532	\$207.29	9/25/2012
1014838-117425872	1008540	110012549	21081 BISHOP RD APT 3	FAIRHOPE	AL	36532	\$346.13	9/25/2012
1008136-110016911	1002064	102050905	10904 COUNTY RD 24	FAIRHOPE	AL	36532	\$50.78	9/27/2012
1005337-104106633	1012483	116166980	518 GENERAL GIBSON DR	SPANISH FORT	AL	36527	\$81.54	9/27/2012
1017782-119049606	1015483	117610567	21310 COUNTY RD 27 LOT 18	FAIRHOPE	AL	36532	\$14.04	9/28/2012
1013216-117040913	1003995	103025703	10 1/2 N SECTION ST	FAIRHOPE	AL	36532	\$3,349.11	9/28/2012
1002142-113040637	1017089	119459862	P.O. BOX 385	STAPLETON	AL	36578	\$11.35	9/28/2012
1021580-121067506	1001875	102038451	11167 MCKENZIE RD #A	FAIRHOPE	AL	36532	\$133.66	9/28/2012
1009331-111028572	1018980	119125404	9625 TWIN BEECH RD #2	FAIRHOPE	AL	36532	\$37.15	10/1/2013
1017844-119258967	1001775	102050958	PO BOX 16	FAIRHOPE	AL	36533	\$113.30	10/1/2013
1001810-102050528	1004936	104106506	14150 SPECS LN #17	SUMMERDALE	AL	36580	\$38.26	10/2/2013
1019133-119259605	1013214	117040862	10751 CILMAN LANE	ELBERTA	AL	36530	\$31.89	10/2/2013
1017006-118080427	1014166	117265486	103 ROYAL AVE	FAIRHOPE	AL	36533	\$399.71	10/2/2013
1019964-119568741	1023769	125901182	9614 NOTTINGHAM CT	DAPHNE	AL	36526	\$142.35	10/2/2013
1020953-120090610	1009343	111029587	221 DE SALES AVE APT D	MOBILE	AL	36607	\$562.57	10/3/2013
1015728-117611179	1008970	110023731	205 PATRICIAN ST	FAIRHOPE	AL	36532	\$589.62	10/4/2013
1013222-117040905	1006536	109058403	7751 HILTON DR	THEODORE	AL	36609	\$546.18	10/4/2013
1004621-104125705	1015444	117611261	10224 MISSION TRACE	FAIRHOPE	AL	36532	\$22.19	10/7/2013
1022809-124002215	1018078	119548703	9104 MORPHY AVE LOT 16	FAIRHOPE	AL	36532	\$84.78	10/7/2013
1013931-117146900	1003773	103625902	12144 MEADOW RD #27	FAIRHOPE	AL	36532	\$306.48	10/7/2013
1009148-110092723	1000236	109016447	1265 WATERBURY PL	TROY	OH	45373	\$159.13	10/8/2013
1007832-110018201	1021529	121085474	12834 COUNTY RD 1	FAIRHOPE	AL	36532	\$198.47	10/8/2013
1008912-110069862	1012533	116156480	513 SPANISH MAIN	SPANISH FORT	AL	36527	\$168.03	10/9/2013
1012001-115312589	1003323	103063225	9803 SILVERWOOD DR	FAIRHOPE	AL	36532	\$8.78	10/11/2013
1009631-111053181	1005209	104125506	14340 COUNTY RD 28	SUMMERDALE	AL	36580	\$134.78	10/14/2013
1001761-102012543	1019353	119258977	5916 N BAY POINT DRIVE	PENSACOLA	FL	32507	\$2.42	10/14/2013
1007279-110095952	1009912	111086585	38 GLENN ACRES DR	JACKSON	TN	38301	\$1,209.05	10/14/2013
1014371-117325486	1022809	124002215	119 WILLOW LAKE DR	FAIRHOPE	AL	36532	\$125.08	10/15/2013

City of Fairhope

Write off Customer Terminated balances as of 6/01/2021

Customer Info	Property ID	Customer ID	Address 1	City	State	Zip Code	Total Unpaid	Stop Date
1015089-117130632	1002398	103063287	P.O. BOX 182692	COLUMBUS	OH	43218	\$14.04	10/15/2013
1006734-110017989	1009051	110452103	901 GAYFER AVE APT 312	FAIRHOPE	AL	36532	\$570.28	10/15/2013
1015647-117254714	1017987	119567841	120 DEWBERRY LANE	MAYLENE	AL	35114	(\$0.70)	10/15/2013
1017806-119257100	1004773	104155261	13030 SINGLETON LN	SUMMERDALE	AL	36580	\$62.08	10/16/2013
1007814-110017376	1017754	119006009	PO BOX 192	DAPHNE	AL	36526	\$10.92	10/17/2013
1006211-109025741	1016120	117375158	16935 SUGAR LOOP	FOLEY	AL	36535	\$90.99	10/17/2013
1015072-117452602	1005334	104106004	25223 PINE STRET UNIT B	ELBERTA	AL	36530	\$60.54	10/17/2013
1016142-117376007	1000850	101059617	320 PINEVIEW LN	MOBILE	AL	36608	\$19.15	10/18/2013
1013242-117040819	1005462	105014738	595 HICKS RD	NASHVILLE	TN	37221	\$220.72	10/18/2013
1013751-117125610	1012316	116452303	PO BOX 1177	MANDAN	ND	58554	\$159.59	10/21/2013
1000491-119004152	1004433	104155607	19138 MEADOW DOVE LN #19	SILVERHILL	AL	36576	\$17.66	10/21/2013
1004433-104155602	1014482	117305446	19837 QUAIL CREEK DR	FAIRHOPE	AL	36532	(\$22.00)	10/22/2013
1015477-117626511	1017699	119003709	19152 HANKINS LANE	FAIRHOPE	AL	36532	\$1,028.94	10/23/2013
1017747-119855600	1019521	119004917	908 HOUSTON PARK	SELMA	AL	36701	\$558.49	10/25/2013
1005088-104107684	1015477	117626511	108 ROSSBURG DR	CALERA	AL	35040	\$97.31	10/30/2013
1006984-110019238	1017853	119258405	PO BOX 825	FAIRHOPE	AL	36533	\$2.42	10/30/2013
1021007-121055694	1002181	102003264	P.O. BOX 1062	MONTROSE	AL	36559	\$179.42	10/30/2013
1014324-117326542	1013597	117082560	1000 D'OLIVE SPRINGS F3	DAPHNE	AL	36526	\$44.31	11/1/2013
1009690-111026610	1017825	119257130	13329 MORIAH DRIVE	SUMMERDALE	AL	36580	\$63.93	11/1/2013
1018867-119003768	1010925	114026620	22555 WEDGEWOOD DR	FOLEY	AL	36535	\$319.35	11/1/2013
1017183-119123600	1017165	119564896	19152 CEDAR LANE	FAIRHOPE	AL	36532	(\$0.70)	11/4/2013
1019151-119005436	1006492	109037715	205 PLUM RD	BARNWELL	SC	29812	\$230.45	11/4/2013
1009932-111065871	1017681	119571422	7254 TWIN BEECH RD	FAIRHOPE	AL	36532	\$417.53	11/5/2013
1006332-109016012	1017549	119000969	PO BOX 367	REDAN	GA	30074	\$86.49	11/5/2013
1018052-119452104	1014422	117325729	8321 AMOHA DR	DIAMONDHEAD	MS	39525	\$176.52	11/5/2013
1015308-117256997	1021456	121081577	11611 BRENDA RD	FAIRHOPE	AL	36532	(\$22.43)	11/5/2013
1005973-108125479	1000484	119000259	18924 DENTON LN	FAIRHOPE	AL	36532	\$158.12	11/5/2013
1017783-119257200	1017742	119258691	19170 YOUNG ST UNIT A	FAIRHOPE	AL	36532	\$247.76	11/5/2013
1014196-117855078	1016992	118065421	306 MARCELLA AVE	SPANISH FT	AL	36527	\$52.79	11/5/2013
1008913-110067583	1012263	116083500	2600 1ST AVE S #206	BIRMINGHAM	AL	35203	(\$35.17)	11/6/2013
1009088-110086562	1006246	109026623	7695 LLOYD LN	FAIRHOPE	AL	36532	\$176.96	11/7/2013
1003330-103066588	1005333	104106579	6980 COOK AVENUE	IRVINGTON	AL	36544	\$212.90	11/7/2013
1006211-109025683	1012360	116600515	36 SUMMER OAKS DR	DAPHNE	AL	36526	\$46.67	11/8/2013
1009112-110099561	1007296	110236592	109 SPRING DR	FAIRHOPE	AL	36532	\$266.67	11/8/2013
1000850-101059612	1009022	110045898	460AM FLOWERS RD	BATESVILLE	MS	38606	\$206.75	11/8/2013
1004271-104006997	1018078	119548704	9104 MORPHY AVE LOT 16	FAIRHOPE	AL	36532	\$7.64	11/9/2013
1009690-111026591	1002074	102050883	10798 COUNTY RD 24	FAIRHOPE	AL	36532	\$87.03	11/13/2013
1005088-104107683	1005356	104100198	13604B COUNTY RD 28	SUMMERDALE	AL	36580	\$66.43	11/14/2013
1009913-111037450	1014916	117625459	12731 CLAY CITY RD #B	FAIRHOPE	AL	36532	\$78.60	11/15/2013
1017829-119258968	1005147	104102361	306 W FIG	FOLEY	AL	36535	\$70.99	11/15/2013
1023739-125901163	1004686	104101141	3301 PINE BARREN RD	MCDAVID	FL	32568	\$6.61	11/18/2013
1013603-117081133	1002090	102050928	10824 SANDY LANE	FAIRHOPE	AL	36532	\$2.69	11/18/2013
1012016-115362005	1003195	103060364	8253 TWIN BEECH RD	FAIRHOPE	AL	36532	(\$0.70)	11/21/2013
1011433-115147009	1009148	110092701	901 GAYFER AVE APT 822	FAIRHOPE	AL	36533	\$466.80	11/22/2013
1000291-110045011	1018606	119006049	1 WOODSIDE	HATTIESBURG	MS	39402	\$34.50	11/22/2013
1001677-102041167	1002397	103065537	14230 COUNTY RD 3 #E	FAIRHOPE	AL	36532	\$181.63	11/22/2013
1013768-110096723	1013686	117126611	201 SPRINGRUN APT 29	FAIRHOPE	AL	36532	\$436.82	11/22/2013
1009097-110023863	1013531	117855472	37420 TEMPLE AVE	ZEPHYRHILLS	FL	33541	\$8.31	11/25/2013
1003503-103065374	1012459	116110204	24 CAISSON TRACE	SPANISH FT	AL	36527	\$125.46	11/26/2013
1005300-104125619	1022714	124003487	8648 LAMHATTY LN	DAPHNE	AL	36526	\$1.06	11/27/2013
1011940-115298904	1003770	103063282	12144 MEADOW RD #19	FAIRHOPE	AL	36532	\$87.74	11/27/2013
1017853-119258405	1011661	115256904	9175 B OLD MOBILE RD	SPANISH FORT	AL	36527	\$44.44	11/27/2013
1004351-104125622	1009920	111452602	19124 CEDAR LN	FAIRHOPE	AL	36532	\$792.86	11/27/2013
1010108-111025447	1013581	117098744	200 AUTUMN DR #3D	FAIRHOPE	AL	36532	\$478.69	12/2/2013
1011576-115259165	1013553	117079131	198 AUTUMN DR LOT 11	FAIRHOPE	AL	36532	\$215.49	12/2/2013
1017553-119000792	1011529	115191013	2881 HWY 21 LOT 17	ATMORE	AL	36502	\$33.09	12/2/2013
1007347-110048103	1016410	117785480	9704 CHARIOT AVE	FAIRHOPE	AL	36532	\$78.10	12/2/2013
1009121-110095928	1013802	117125468	31230 STAGECOACH RD	SPANISH FORT	AL	36527	\$232.19	12/3/2013
1017747-119855601	1013377	117099517	19327 S GREENO RD	FAIRHOPE	AL	36532	\$223.17	12/3/2013
1009091-110096675	1014964	117130100	209 SOUTHCHASE COURT	FAIRHOPE	AL	36532	\$1,006.73	12/3/2013
1013559-117126639	1013698	117127454	201 SPRINGRUN APT 46	FAIRHOPE	AL	36532	\$456.67	12/5/2013
1009922-111258603	1006300	109045213	19455 YOUNG ST	FAIRHOPE	AL	36532	\$317.96	12/5/2013

City of Fairhope

Write off Customer Terminated balances as of 6/01/2021

Customer Info	Property ID	Customer ID	Address 1	City	State	Zip Code	Total Unpaid	Stop Date
1006523-109046952	1002098	102057023	10715 COUNTY RD 24	FAIRHOPE	AL	36532	\$28.34	12/9/2013
1006536-109058403	1006859	110025740	6 N GRAND BLVD	FAIRHOPE	AL	36532	\$578.27	12/10/2013
1009117-110098483	1009310	111008505	23268 CORNER STONE DR	LOXLEY	AL	36551	\$344.12	12/10/2013
1007908-110026632	1005364	104100450	10435 LONG VIEW DR	FOLEY	AL	36535	\$55.11	12/10/2013
1001668-102052059	1003976	103061544	P O BOX 481	POINT CLEAR	AL	36564	\$46.25	12/10/2013
1009608-111044502	1011271	114028467	312 LIBERTY ST	FAIRHOPE	AL	36532	\$305.75	12/11/2013
1005362-104106651	1018653	119578403	150 OAKWOOD AVE	FAIRHOPE	AL	36532	\$949.56	12/11/2013
1012585-116181408	1005124	104102507	13860 ISLE OF PINES DR	MAGNOLIA SPGS	AL	36535	\$60.97	12/12/2013
1005124-104102507	1009924	111065495	806 N GREENO RD #14	FAIRHOPE	AL	36532	\$145.49	12/13/2013
1009192-110095810	1004975	104125363	19974 FOREST PARK CIRCLE	FOLEY	AL	36580	\$82.58	12/13/2013
1001921-102050571	1010990	114028453	20411 EAST BLVD	SILVERHILL	AL	36576	\$203.58	12/13/2013
1006951-110027454	1005203	104158300	14200 COUNTY RD 28	SUMMERDALE	AL	36580	\$67.74	12/16/2013
1015758-117659801	1004921	104106532	12846 UNDERWOOD RD	SUMMERDALE	AL	36580	\$7.02	12/16/2013
1014883-117598013	1004674	104104362	16688 COUNTY RD 9	SUMMERDALE	AL	36580	\$92.78	12/16/2013
1004267-104256992	1001744	102042362	10420 HWY 98	FAIRHOPE	AL	36532	\$22.41	12/17/2013
1013657-117854606	1013794	117120250	199 SPRINGRUN DR	FAIRHOPE	AL	36532	\$2,608.52	12/17/2013
1004324-104152631	1019151	119005335	13441 CHRIS HIERS RD	FAIRHOPE	AL	36532	\$189.43	12/19/2013
1017807-119254602	1005300	104125624	15591 COUNTY RD 49 #5	SUMMERDALE	AL	36580	\$118.96	12/19/2013
1008864-110062793	1006475	109026828	394 S INGLESIDE ST	FAIRHOPE	AL	36532	\$814.87	12/20/2013
1017196-119256959	1022008	123159632	10407 US HWY 31 #1027	SPANISH FORT	AL	36527	\$54.97	12/20/2013
1004447-104110530	1003673	103064051	11260 COUNTY RD 32 #B	FAIRHOPE	AL	36532	\$11.35	12/20/2013
1013541-117080160	1017665	119213601	101 CARMEN COURT	KISSIMMEE	FL	34743	\$71.58	12/23/2013
1008961-110099503	1006604	109057003	PO BOX 703	DAPHNE	AL	36526	\$23.49	12/23/2013
1018978-119258914	1022558	124003346	124 OOSTANALI WAY	LOUDON	TN	37774	(\$9.08)	12/23/2013
1005206-104107960	1013542	117079505	P.O. BOX 1393	ROBERTSDALE	AL	36567	\$702.01	12/23/2013
1007824-110017966	1013556	117085705	1060 WEST UNION AVE	LOXLEY	AL	36551	\$691.08	12/30/2013
1015488-117611001	1005091	104102613	12855 CLAY CITY RD	FAIRHOPE	AL	36532	\$4.63	12/30/2013
1008413-110023949	1008042	110256907	20765 BISHOP RD APT 305	FAIRHOPE	AL	36532	\$108.55	12/31/2013
1018093-119125600	1004125	103052024	121 KURLANE	FAIRHOPE	AL	36532	\$2.59	1/2/2014
1014977-117130515	1017910	119235602	2532 S DANIELS RD	MOBILE	AL	36605	\$253.08	1/2/2014
1001867-102050956	1007908	110026632	422 POJ STATION RD	PENSACOLA	FL	32507	\$990.40	1/2/2014
1017123-119000328	1014761	117377047	19836 BUDS LN	FAIRHOPE	AL	36532	\$100.64	1/7/2014
1003503-103065363	1013765	117120748	15125 SOUTH BLVD	SILVERHILL	AL	36576	\$209.01	1/7/2014
1001250-102045108	1013560	117079218	136 MONTICLAIR LOOP	DAPHNE	AL	36526	\$495.82	1/7/2014
1001250-102045113	1005360	104106635	PO BOX 794	MAGNOLIA SPR	AL	36555	\$101.66	1/8/2014
1018916-119568789	1003330	103066588	15423 HWY 181	FAIRHOPE	AL	36532	\$9.66	1/9/2014
1008536-110018126	1006232	109026582	411 YOUNG ST	FAIRHOPE	AL	36532	\$1,039.12	1/9/2014
1018085-119564230	1006181	109058206	PO BOX 354	POINT CLEAR	AL	36564	\$967.34	1/9/2014
1024192-125863505	1013565	117075800	1417 AZALEA RD	MOBILE	AL	36609	\$587.49	1/10/2014
1009310-111008505	1007102	110036527	20767 LAWRENCE RD	FAIRHOPE	AL	36532	\$175.00	1/10/2014
1005587-106021135	1001763	102046987	9650 US HWY 98 LOT 7	FAIRHOPE	AL	36532	\$240.57	1/14/2014
1009929-111067463	1004808	104125623	15713 COUNTY RD 9	SUMMERDALE	AL	36580	\$976.31	1/15/2014
1011579-115259116	1005359	104125485	32095 BUSBY RD	SP FORT	AL	36527	\$73.51	1/15/2014
1017007-118089750	1008991	110090451	253 JEFF DAVIS RD	FAIRHOPE	AL	36532	\$1,017.00	1/16/2014
1018650-119002677	1014368	117305447	210 ELEANOR DR	FAIRHOPE	AL	36532	\$95.54	1/21/2014
1008574-110025520	1013551	117079061	1404 WARREN DR	DAPHNE	AL	36526	\$1,139.31	1/21/2014
1013226-117040816	1001755	102050969	12898 KELLER RD	FAIRHOPE	AL	36532	\$2.69	1/22/2014
1002371-103063166	1006848	110125474	812 FAIRHOPE AVE	FAIRHOPE	AL	36532	\$849.42	1/22/2014
1006665-109066588	1009013	110096750	901 GAYFER AVE APT 123	FAIRHOPE	AL	36532	\$736.21	1/22/2014
1001950-102050487	1005241	104110504	16219 W INDIGO LOOP	SUMMERDALE	AL	36580	\$0.87	1/23/2014
1008573-110026604	1003384	103060416	P.O. BOX 537	DAPHNE	AL	36526	\$35.67	1/24/2014
1015447-117625508	1001950	102050487	PO BOX 7554	SPANISH FT	AL	36577	\$57.02	1/24/2014
1013726-117126501	1007556	110025784	PO BOX 37	MONTROSE	AL	36559	\$6,311.15	1/27/2014
1013556-117085696	1013321	117058569	319 MAGNOLIA AVE	FAIRHOPE	AL	36533	\$15.02	1/28/2014
1000523-121125690	1009922	111258602	806 N GREENO RD #12	FAIRHOPE	AL	36532	\$971.14	1/30/2014
1017484-119001321	1008549	110018097	114 EAGLE DR	DAPHNE	AL	36526	\$660.66	1/30/2014
1011938-115298704	1024021	125008560	21547 BARTLETT LANE	ROBERTSDALE	AL	36567	\$283.42	1/30/2014
1022339-124513608	1007228	110047879	9661 CALLAWAY DR	FAIRHOPE	AL	36532	\$169.94	1/31/2014
1022668-124002675	1009916	111075844	806 N GREENO RD LOT 7	FAIRHOPE	AL	36532	\$306.85	1/31/2014
1005360-104106638	1003442	103066581	24513 PECAN COURT	LOXLEY	AL	36551	\$146.43	2/3/2014
1002164-102003017	1005492	105005559	106 GENERAL CAMBY DR	SPANISH FORT	AL	36527	\$236.97	2/3/2014
1001742-102042365	1013764	117125554	PO BOX 1316	FAIRHOPE	AL	36533	\$157.87	2/3/2014

City of Fairhope

Write off Customer Terminated balances as of 6/01/2021

Customer Info	Property ID	Customer ID	Address 1	City	State	Zip Code	Total Unpaid	Stop Date
1008961-110099502	1004592	104103627	54 RIDGELAWN DR	MOBILE	AL	36608	\$8.78	2/3/2014
1015991-117040716	1018078	119548705	PO BOX 23	FOLEY	AL	36536	\$1.40	2/4/2014
1022841-124056390	1013555	117085607	10194 MISSION TRACE	FAIRHOPE	AL	36532	\$552.33	2/4/2014
1006869-110026645	1000052	102045617	9650 HWY 98 LOT 16	FAIRHOPE	AL	36532	\$53.00	2/4/2014
1010712-113035413	1015450	117625891	25233 PINE ST #A	ELBERTA	AL	36530	\$87.44	2/4/2014
1011404-115137820	1012509	116182542	3000 TOWN CENTER AVE	SPANISH FORT	AL	36527	\$561.01	2/6/2014
1012489-116175484	1000644	125862027	623 CRENSHAW ST	MOBILE	AL	36606	\$12.12	2/6/2014
1010074-111017475	1005042	104106628	20050 OAK RD E #1908	GULF SHORES	AL	36542	(\$0.70)	2/7/2014
1010071-111017523	1013568	117089506	11130 B COUNTY RD 32	FAIRHOPE	AL	36532	\$77.59	2/8/2014
1010073-111017525	1021795	122050352	P.O. BOX 203	PT CLEAR	AL	36564	\$2.69	2/10/2014
1007374-110050415	1021763	122050347	PO BOX 434	POINT CLEAR	AL	36564	\$117.22	2/10/2014
1007373-110050418	1004700	104105239	16325 COUNTY RD 9	SUMMERDALE	AL	36580	\$66.63	2/11/2014
1013525-117079133	1004463	104102700	18918 EAST RIVER RD S	SILVERHILL	AL	36576	\$44.32	2/11/2014
1006617-109059728	1015636	117610450	18150 ALICE LN #26	SUMMERDALE	AL	36580	\$15.67	2/13/2014
1010844-114006906	1015080	117126624	807 CRYSTAL WELLS CT S	FAIRHOPE	AL	36532	\$827.75	2/13/2014
1013232-117045922	1005362	104106637	15943 RED STAR DR #27	SUMMERDALE	AL	36580	\$89.82	2/14/2014
1008016-110002000	1000398	115295870	30855 WATER TOWER RD # F	SP FORT	AL	36527	\$105.67	2/19/2014
1017153-119000462	1008988	110090422	20050 OAKDALE LANE	ROBERTSDALE	AL	36567	(\$9.08)	2/20/2014
1005208-104107957	1009373	111014136	415 MILLER AVE	FAIRHOPE	AL	36532	\$316.11	2/20/2014
1003418-103061722	1017060	118103701	12393 STATE HWY 104	FAIRHOPE	AL	36532	\$249.83	2/21/2014
1022010-123162502	1004690	104104423	13692 PENDIX RD LOT B-2	SUMMERDALE	AL	36580	\$37.30	2/24/2014
1000465-117620012	1000503	120070415	19480 WESTON LN #A	FAIRHOPE	AL	36532	(\$8.04)	2/26/2014
1010730-113034831	1013560	117079219	10194 MISSION TRACE #18	FAIRHOPE	AL	36532	\$581.12	2/26/2014
1019151-119005335	1013235	117040867	9556 COUNTY RD 34 #5	FAIRHOPE	AL	36532	\$194.35	2/27/2014
1001420-102040399	1010712	113035413	560 SATSUMA ST APT G	FAIRHOPE	AL	36532	\$657.35	2/28/2014
1017665-119213601	1020658	120051523	3660 GRANDVIEW PKWY	BIRMINGHAM	AL	35243	(\$15.38)	2/28/2014
1001755-102050969	1015610	117621300	5205 SWEETBRIAR LN	EIGHT MILE	AL	36613	\$96.42	2/28/2014
1015896-117046988	1009148	110092723	15542 PECAN VIEW DRIVE	LOXLEY	AL	36551	\$491.25	3/3/2014
1013517-117080129	1013425	117066257	160 CYPRESS LN	FAIRHOPE	AL	36532	\$111.78	3/3/2014
1020814-120070439	1008581	110095836	608 DRYER AVE	DAPHNE	AL	36526	\$109.08	3/3/2014
1021282-121029716	1015480	117610756	21400 STATE HWY 181 #2	FAIRHOPE	AL	36532	\$116.51	3/4/2014
1001010-101125473	1011250	114023682	15698 DANNE RD	FAIRHOPE	AL	36532	\$100.00	3/4/2014
1005561-106021541	1016208	117611023	325 J MICHAEL ST	FAIRHOPE	AL	36532	\$122.56	3/4/2014
1005560-106023664	1009921	111075494	201 SPRINGRUN DR APT 32	FAIRHOPE	AL	36532	\$123.88	3/4/2014
1001761-102012541	1019246	119564821	15890 S BLVD LOT 3	SPRINGHILL	AL	36576	\$94.80	3/5/2014
1001668-102052057	1016758	117042129	82 PLANTATION POINT RD #128	FAIRHOPE	AL	36532	\$95.10	3/5/2014
1009163-110092766	1017201	119255746	6843 TWIN BEECH RD #E	FAIRHOPE	AL	36532	\$169.80	3/5/2014
1023838-125890040	1013259	117040791	9651 B CO RD 34	FAIRHOPE	AL	36532	\$134.15	3/5/2014
1001886-102057485	1013726	117126501	201 SPRINGRUN APT 14	FAIRHOPE	AL	36532	\$244.48	3/6/2014
1009257-111057008	1016972	118012305	251 MARCELLA AVE	SPANISH FORT	AL	36527	\$50.35	3/6/2014
1009207-110096722	1010284	112018510	10 N SECTION ST #12	FAIRHOPE	AL	36532	\$1,676.73	3/6/2014
1003499-103061235	1009105	110254699	901 GAYFER AVE APT 621	FAIRHOPE	AL	36532	\$510.74	3/6/2014
1017810-119257230	1017844	119258967	104 CARRIE LANE APT 11	TUSCUMBIA	AL	35674	\$43.62	3/7/2014
1005362-104106639	1024217	125314602	PO BOX 7413	SPANISH FORT	AL	36577	\$23.50	3/7/2014
1009282-111028514	1022846	124569830	11546 WENTWOOD CT	DAPHNE	AL	36526	\$365.15	3/7/2014
1002307-103063278	1002918	109057003	P.O. BOX 703	DAPHNE	AL	36526	\$692.04	3/12/2014
1006876-110025685	1009024	110095816	15823 SILVERHILL AVE	SILVERHILL	AL	36576	\$724.80	3/12/2014
1004073-103085694	1009094	110095876	101 HIGHLAND CIRCLE	DAPHNE	AL	36526	\$239.14	3/17/2014
1015315-117856473	1002455	103066567	7560 RABBIT RUN RD	FAIRHOPE	AL	36532	(\$5.96)	3/17/2014
1009092-110091738	1015647	117254714	7800 MG WATSON	BAY MINETTE	AL	36507	\$62.04	3/18/2014
1013291-117056714	1024019	125256981	930 DAUPHINE CIRCLE	DAPHNE	AL	36526	\$132.87	3/18/2014
1013510-117080717	1004271	104006997	208 FAIRHOPE AVE #4	FAIRHOPE	AL	36532	\$260.56	3/19/2014
1018942-119003432	1011940	115298904	31380 STAGECOACH RD	SPANISH FORT	AL	36527	(\$7.11)	3/19/2014
1008484-110014066	1008559	110023865	8545 SOUTHWOOD CT APT A	FAIRHOPE	AL	36532	\$518.50	3/20/2014
1008413-110023845	1006919	110025712	4301 JEFFREY DR	BATON ROUGE	LA	70816	\$490.16	3/20/2014
1004681-104101208	1009184	110098482	7605 AUDUBON DR	FOLEY	AL	36535	\$656.56	3/21/2014
1005207-104125615	1009925	111065333	806 N GREENO RD #15	FAIRHOPE	AL	36532	\$851.46	3/24/2014
1017754-119006009	1013232	117045922	8160 COUNTY RD 64 #622	DAPHNE	AL	36526	(\$5.96)	3/24/2014
1003497-103062823	1004992	104106662	7638 BRANDON CIRCLE	FOLEY	AL	36535	\$31.06	3/25/2014
1015440-117611121	1006730	110004038	755 NORTHPROP ST	FAIRHOPE	AL	36532	\$1,155.87	3/27/2014
1013523-117085488	1015072	117452602	706 CRYSTAL WELLS CT N	FAIRHOPE	AL	36532	\$698.80	3/28/2014
1002779-103652947	1009366	111237453	9902 S THOMAS DR #1437	P C BEACH	FL	32408	\$849.56	3/28/2014

City of Fairhope

Write off Customer Terminated balances as of 6/01/2021

Customer Info	Property ID	Customer ID	Address 1	City	State	Zip Code	Total Unpaid	Stop Date
1011367-115135533	1005646	107028503	20050 OAK ROAD E #1701	GULF SHORES	AL	36542	\$790.24	3/28/2014
1009921-111075500	1003723	103061288	PO BOX 1630	FAIRHOPE	AL	36533	\$118.11	3/28/2014
1006330-109425600	1009088	110086562	160 S WARREN ST	MOBILE	AL	36602	\$160.22	4/1/2014
1018999-119005811	1001886	102057485	110 GRAND BLVD	MOBILE	AL	36607	\$28.78	4/1/2014
1017820-119256801	1008073	110018084	350 POMELO	FAIRHOPE	AL	36532	\$98.36	4/1/2014
1009398-111013485	1017748	119858903	19265 YOUNG ST UNIT A	FAIRHOPE	AL	36532	\$188.54	4/1/2014
1016758-117042202	1009340	111026617	13456 SANCTUARY DR	FOLEY	AL	36535	\$813.27	4/1/2014
1013560-117079221	1009305	111255600	3444 CLAYS MILL RD	LEXINGTON	KY	40503	\$504.19	4/1/2014
1012243-116042501	1013793	117126618	199 SPRINGRUN RD APT 133	FAIRHOPE	AL	36532	\$650.15	4/2/2014
1015015-117023581	1022111	124125713	20050 OAK RD E #3213	GULF SHORES	AL	36542	\$48.98	4/3/2014
1003241-103063042	1017833	119568719	2345 PETTIS CT A	PENSACOLA	FL	32507	\$125.01	4/7/2014
1015421-117782108	1002307	103063278	15292 CELESTE RD	CHUNCHULA	AL	36521	\$26.96	4/7/2014
1006077-109016762	1004066	103018080	27763 MONIAC COVE	DAPHNE	AL	36526	\$33.11	4/7/2014
1013955-117786543	1006071	109016436	16 LEE CIRCLE	SPANISH FORT	AL	36527	\$31.57	4/7/2014
1009182-110964006	1023955	125930281	12034 SQUIRREL DR	SPANISH FORT	AL	36527	\$84.62	4/8/2014
1013590-117081047	1015750	117611061	9305 GAYFER RD	FAIRHOPE	AL	36532	\$100.54	4/10/2014
1017674-119001030	1017820	119256801	27642 US HWY 98 #831	DAPHNE	AL	36526	\$140.91	4/14/2014
1002630-103065509	1009050	110125511	5420 LUSANN DR	MOBILE	AL	36608	\$167.15	4/14/2014
1006149-109016735	1013941	117180068	9 BURLINGTON DR	FAIRHOPE	AL	36532	\$669.55	4/14/2014
1011175-114017897	1004115	103025401	323 DE LA MARE AVE	FAIRHOPE	AL	36532	\$312.47	4/15/2014
1019141-119005941	1000156	103037509	323 DE LA MARE AVE	FAIRHOPE	AL	36532	\$395.96	4/15/2014
1007758-110452870	1008970	110023736	205 PATRICIAN ST	FAIRHOPE	AL	36532	\$1,405.64	4/16/2014
1012746-116185480	1017875	119003446	8160 COUNTY RD 64 #1613	DAPHNE	AL	36526	\$182.94	4/16/2014
1002398-103063287	1013783	117059865	4312 WOLFRIDGE RD	MOBILE	AL	36612	\$192.48	4/17/2014
1011384-115135534	1016728	117042164	11309 PATCH LN	FAIRHOPE	AL	36532	\$147.87	4/21/2014
1017808-119257490	1014496	117325413	1806 COXEMOOR PLACE	ASHEBORO	NC	27205	\$21.62	4/21/2014
1001738-102055461	1018834	119564879	PO BOX 646	MONTROSE	AL	36559	(\$5.92)	4/21/2014
1003791-103065318	1021984	123156016	121 WINDSOR DR	DAPHNE	AL	36526	\$459.88	4/21/2014
1004641-104104134	1011600	115021547	30729 WALLING ROAD	SPANISH FORT	AL	36527	\$437.49	4/21/2014
1014332-117325484	1003502	103061104	PO BOX 105	ROBERTSDALE	AL	36567	\$41.70	4/21/2014
1013557-117589602	1019125	119006061	108 WINDWOOD CIRCLE	DAPHNE	AL	36526	\$17.66	4/22/2014
1013846-117105691	1006896	110018959	302 WAKEFIELD AVE	FAIRHOPE	AL	36532	\$573.82	4/23/2014
1005019-104126604	1007207	110047564	19120 HIGHWAY 181 LOT D	FAIRHOPE	AL	36532	\$754.26	4/23/2014
1021700-122050295	1014457	117375175	156 ROLLING HILL DR	DAPHNE	AL	36526	\$81.67	4/23/2014
1003959-103062806	1013234	117045704	9556 COUNTY RD 34 LQT 4	FAIRHOPE	AL	36532	\$17.86	4/23/2014
1014761-117377047	1009134	110074580	PO BOX 891	FAIRHOPE	AL	36532	\$430.62	4/24/2014
1021682-122052362	1017180	119257058	7285 KIRKMAN LN	FAIRHOPE	AL	36532	\$566.38	4/25/2014
1012307-116242100	1004351	104125622	13823 WHITE RD	SILVERHILL	AL	36576	\$13.33	4/25/2014
1021681-122056986	1008553	110025624	8570 SOUTHWOOD CT APT 9	FAIRHOPE	AL	36532	\$490.13	4/25/2014
1000836-101055699	1013244	117040870	P.O. BOX 241	FAIRHOPE	AL	36533	(\$0.70)	4/29/2014
1007719-110026572	1013528	117086547	198 AUTUMN DR LOT 51	FAIRHOPE	AL	36532	\$978.22	4/29/2014
1006159-109026592	1012016	115362003	16086 COUNTY RD 28 #C	SUMMERDALE	AL	36580	\$302.00	4/30/2014
1004595-104526983	1019225	119237851	341 RIVER FARMS LN	MILLBROOK	AL	36054	\$57.74	5/1/2014
1005364-104100450	1012293	116625409	107 SPANISH MAIN	SPANISH FORT	AL	36527	\$27.85	5/1/2014
1016120-117375158	1017193	119000525	6840 TWIN BEECH RD	FAIRHOPE	AL	36532	\$14.04	5/2/2014
1015755-117659803	1017807	119254602	8254 COUNTY RD 64 #2402	DAPHNE	AL	36526	\$121.96	5/5/2014
1009919-111037920	1008647	110036526	8281 GAYFER RD EXT # C	FAIRHOPE	AL	36532	\$258.21	5/5/2014
1002181-102003264	1018686	119257133	411 W PORTAGE	MUSSEL SHOALS	AL	35661	\$78.02	5/5/2014
1018698-119003030	1001733	102045134	9650 US HWY 98 LOT 20	FAIRHOPE	AL	36532	\$183.56	5/5/2014
1020632-120052155	1001196	102040420	7187 WYNNCLIFF DR	MOBILE	AL	36695	(\$6.88)	5/5/2014
1006099-109016582	1013699	117115803	201 SPRINGRUN APT 45	FAIRHOPE	AL	36532	\$350.35	5/6/2014
1013764-117125554	1000877	101059528	7 AZALEA COURT	FAIRHOPE	AL	36532	\$827.33	5/7/2014
1001287-102041253	1001746	102042351	9560 US HWY 98 LOT 30	FAIRHOPE	AL	36532	\$8.05	5/7/2014
1015695-117855477	1013547	117079123	19840 BUDS LN	FAIRHOPE	AL	36532	\$489.05	5/7/2014
1006250-109027451	1017144	119005725	2304 LOCKE LANE	DAPHNE	AL	36526	\$89.43	5/7/2014
1008924-110090374	1019151	119005436	19045 STATE HWY 181	FAIRHOPE	AL	36532	\$129.12	5/8/2014
1018838-119003203	1003685	103064054	PO BOX 2168	FAIRHOPE	AL	36533	\$8.78	5/8/2014
1006605-109056995	1024059	125000630	26903 AUGUSTINE DR	DAPHNE	AL	36526	(\$10.14)	5/8/2014
1004700-104105238	1009069	110023856	103 RAINER CIR	DAPHNE	AL	36526	\$348.12	5/9/2014
1013556-117085705	1001826	102050909	10647 HWY 98	FAIRHOPE	AL	36532	\$50.70	5/12/2014
1013133-117045263	1008594	110016787	PO BOX 257	FAIRHOPE	AL	36533	(\$9.08)	5/12/2014
1007232-110047977	1018400	119255740	15020 RIVER RD	FAIRHOPE	AL	36532	\$200.00	5/13/2014

City of Fairhope

Write off Customer Terminated balances as of 6/01/2021

Customer Info	Property ID	Customer ID	Address 1	City	State	Zip Code	Total Unpaid	Stop Date
1008536-110018076	1001225	102040490	115 CONFEDERATE DR	SPANISH FORT	AL	36527	\$14.04	5/13/2014
1009929-111067461	1017182	119123608	6655 TWIN BEECH RD	FAIRHOPE	AL	36532	\$370.80	5/14/2014
1015038-117137450	1003770	103063292	12144 MEADOW RD LOT 19	FAIRHOPE	AL	36532	\$80.26	5/14/2014
1013854-117122231	1003721	103070557	11950 COUNTY RD 32	FAIRHOPE	AL	36532	\$139.32	5/14/2014
1019584-119005601	1003470	103061488	14185 COUNTY RD 13	FAIRHOPE	AL	36532	\$116.43	5/15/2014
1003720-103065468	1001868	102055698	11214 MCKENZIE RD	FAIRHOPE	AL	36532	\$89.34	5/15/2014
1006309-109023690	1002137	102030871	7356 OLD MILL TRAIL	TRUSSVILLE	AL	35173	\$116.24	5/19/2014
1021640-122006500	1009000	110958420	205 JEFF DAVIS B	FAIRHOPE	AL	36532	\$192.77	5/20/2014
1011309-114027459	1000541	122023602	PO BOX 1186	POINT CLEAR	AL	36564	\$51.84	5/20/2014
1002820-103060199	1011321	114125603	P O BOX 436	LOXLEY	AL	36551	\$671.02	5/20/2014
1015475-117622502	1013239	117040871	PO BOX 592	PT CLEAR	AL	36564	\$13.33	5/21/2014
1017694-119256946	1009044	110096749	901 GAYFER AVE #211	FAIRHOPE	AL	36532	\$194.12	5/28/2014
1002346-103065531	1015449	117655234	P O BOX 264	HOLLY RIDGE	NC	28445	\$95.71	5/28/2014
1021299-121056985	1006596	109062500	551 JOHNSON AVE	FAIRHOPE	AL	36532	\$324.75	5/28/2014
1022777-124012546	1001744	102042364	9650 US HWY 98 #29	FAIRHOPE	AL	36532	\$46.23	5/29/2014
1014154-117266994	1014962	117135245	205 SOUTHCHASE CT	FAIRHOPE	AL	36532	\$438.94	5/30/2014
1012483-116166980	1015359	117256932	10558 EASTERN SHORE #812	SPANISH FORT	AL	36527	\$32.30	6/2/2014
1005477-105012603	1013751	117125610	18401 ST HWY 180 APT 37	GULF SHORES	AL	36542	\$73.68	6/2/2014
1009044-110096749	1006020	109057000	101 BRENTWOOD DR	DAPHNE	AL	36526	\$185.85	6/2/2014
1006547-109057401	1013510	117080714	198 AUTUMN DR LOT 42	FAIRHOPE	AL	36532	\$763.06	6/2/2014
1001721-102046581	1009070	110025864	20705 LANGFORD RD	FAIRHOPE	AL	36532	\$133.20	6/2/2014
1009048-110091172	1009919	111069863	806 N GREENO RD LOT 9	FAIRHOPE	AL	36532	\$456.24	6/2/2014
1020185-119258929	1015500	117611212	10 BULL RUN	SPANISH FORT	AL	36527	\$37.30	6/2/2014
1009035-110045915	1001336	102041120	1896 WALKER'S CREEK RD	RCKBRIDGE BTH	VA	24473	\$46.09	6/2/2014
1009405-111013311	1010108	111025447	599 RIDGEWOOD DR	DAPHNE	AL	36526	\$250.51	6/3/2014
1017209-119000769	1002630	103065509	3314 TEMPO LN	FT MILL	SC	29707	\$9.54	6/3/2014
1013555-117085602	1004595	104526983	17847 RIVER RD W	SUMMERDALE	AL	36580	(\$5.96)	6/3/2014
1009595-111041014	1009613	111044215	314 GAYFER CT #10	FAIRHOPE	AL	36532	\$404.65	6/3/2014
1001596-102049957	1013556	117085706	198 AUTUMN DR LOT 9	FAIRHOPE	AL	36532	\$1,265.84	6/4/2014
1015483-117610567	1001742	102042365	9650 US HWY 98 LOT 28	FAIRHOPE	AL	36532	\$755.60	6/4/2014
1015467-117780005	1019187	119004334	19284 STATE HWY 181	FAIRHOPE	AL	36532	\$45.56	6/4/2014
1011253-114028456	1017144	119005731	19114 WILSON LANE	FAIRHOPE	AL	36532	\$18.37	6/4/2014
1010685-113040634	1006857	110015140	2 N GRAND BLVD	FAIRHOPE	AL	36532	\$302.77	6/5/2014
1018364-119002308	1005362	104106639	15943 RED STAR DR LOT 27	SUMMERDALE	AL	36580	\$97.32	6/6/2014
1016466-117787400	1005184	104152608	21910 S SECOND ST	SILVERHILL	AL	36576	\$45.15	6/6/2014
1010746-113038452	1012473	116119514	5 BULL RUN	SPANISH FORT	AL	36527	\$119.64	6/9/2014
1013843-117458705	1023739	125901163	4207 DAUPHIN ISLAND PKWY	MOBILE	AL	36605	\$88.51	6/10/2014
1005203-104158300	1019285	119004813	10753 WINDMILL RD #B	FAIRHOPE	AL	36532	\$916.16	6/10/2014
1002142-102030790	1009912	111066587	P.O. BOX 1931	FAIRHOPE	AL	36533	\$301.52	6/11/2014
1009051-110452103	1014969	117130374	859 SEA CLIFF DR	FAIRHOPE	AL	36532	\$626.99	6/12/2014
1005364-104125911	1007689	110023241	111 W PARK DR	CHARLOTTE'LE	VA	22901	\$98.19	6/12/2014
1005371-104125911	1006206	109025738	609 MIDDLE ST	FAIRHOPE	AL	36532	\$1,307.17	6/16/2014
1006566-109059870	1012233	116036505	3 CONFEDERATE DR S	SPANISH FORT	AL	36527	\$81.15	6/16/2014
1004498-104125761	1006211	109025683	650 FAIRLAND AVE 2ND APT	FAIRHOPE	AL	36532	\$528.63	6/17/2014
1021056-121023660	1013219	117045907	211 ORANGE AVE	FAIRHOPE	AL	36532	\$150.82	6/17/2014
1004262-104256911	1007529	110015628	400 EASTERN SHORE SHOP CT	FAIRHOPE	AL	36532	\$3,637.91	6/18/2014
1004262-104256916	1005110	104107501	P O BOX 811	MAGNOLIA SPGS	AL	36555	\$77.54	6/18/2014
1003768-103070857	1015055	117136523	1012 QUAIL HOLLOW RD	JASPER	AL	35503	\$347.29	6/18/2014
1015006-117095215	1007843	110017109	2114E PHEASANT LANE	HUNTSVILLE	AL	35802	\$222.37	6/19/2014
1017711-119257143	1009064	110095909	901 GAYFER AVE APT 421	FAIRHOPE	AL	36532	\$346.01	6/20/2014
1013747-117279600	1005124	104102508	PO BOX 205	MAGNOLIA SPGS	AL	36555	\$32.60	6/20/2014
1013377-117099517	1010963	114025417	8760 COUNTY RD 64	DAPHNE	AL	36526	\$47.29	6/20/2014
1012314-116240103	1014237	117265674	221 ORLEANS DR	FAIRHOPE	AL	36532	\$45.92	6/20/2014
1018991-119198007	1008227	110052360	25784 ROYALTY DR	DAPHNE	AL	36526	\$58.69	6/23/2014
1002563-103065453	1007801	110017377	8132 GAYFER RD EXT #604	FAIRHOPE	AL	36532	\$755.54	6/23/2014
1003792-103061065	1003708	103065264	PO BOX 353	DAPHNE	AL	36526	\$106.05	6/23/2014
1000482-119256997	1005347	104125736	3736 FARVIEW CIR # 1816	WINTERPARK	FL	32792	(\$6.14)	6/23/2014
1000218-107043014	1006734	110017989	1306 MONTGOMERY ST	DAPHNE	AL	36526	\$62.58	6/24/2014
1001725-102042056	1015974	117045929	179 PEMBERTON LOOP	FAIRHOPE	AL	36532	\$117.54	6/24/2014
1008633-110251451	1005635	107019027	PO BOX 1032	ORANGE BEACH	AL	36561	\$818.16	6/27/2014
1000315-110023171	1001306	102040495	9239 COLES COURT	DAPHNE	AL	36526	\$78.93	6/30/2014
1008147-110782158	1009158	110092783	19096 FAIRGROUNDS RD #D6	ROBERTSDALE	AL	36567	\$238.54	7/1/2014

City of Fairhope

Write off Customer Terminated balances as of 6/01/2021

Customer Info	Property ID	Customer ID	Address 1	City	State	Zip Code	Total Unpaid	Stop Date
1003470-103061475	1010782	113049858	710 S MOBILE ST APT 43	FAIRHOPE	AL	36532	\$104.00	7/1/2014
1009082-110090659	1008409	110025854	21397 SHADY GROVE LN	FAIRHOPE	AL	36532	\$79.73	7/1/2014
1007837-110017858	1011273	114036252	354 LIBERTY ST	FAIRHOPE	AL	36532	\$374.94	7/1/2014
1003470-103061493	1017230	119000651	18280 S SECTION ST	FAIRHOPE	AL	36532	\$22.69	7/2/2014
1013224-117452137	1004463	104102709	18918 E RIVER RD S	FAIRHOPE	AL	36532	\$107.53	7/2/2014
1006034-109058744	1005360	104106638	15921 RED STAR RD LOT 25	SUMMERDALE	AL	36580	\$99.55	7/2/2014
1022016-123081003	1022777	124012546	455 CLUBHOUSE DRIVE	FAIRHOPE	AL	36532	\$647.95	7/2/2014
1014846-117857409	1013567	117125534	7252 KIRKMAN LANE	FAIRHOPE	AL	36532	\$601.57	7/2/2014
1014368-117305442	1013405	117066190	6111 SAWGRASS CIR	GULF SHORES	AL	36542	\$328.24	7/3/2014
1014337-117322505	1017749	119856492	PO BOX 1936	FAIRHOPE	AL	36533	\$39.94	7/3/2014
1005329-104154801	1010575	113026852	26 ORANGE AVE	FAIRHOPE	AL	36532	\$512.27	7/3/2014
1019013-119258928	1009928	111067688	7709 OLD BATTLES RD	FAIRHOPE	AL	36532	\$91.12	7/7/2014
1005807-108003507	1009140	110095428	901 GAYFER AVE APT 825	FAIRHOPE	AL	36532	\$32.64	7/7/2014
1021207-121030908	1004258	104568005	208 FAIRHOPE AVE APT 21	FAIRHOPE	AL	36532	\$556.66	7/7/2014
1002310-103065323	1013231	117045924	200 PARMA D #2	DAPHNE	AL	36526	\$31.49	7/7/2014
1008137-110025530	1017402	119006546	4451 BINGHAMTON DR	MOBILE	AL	36619	\$97.89	7/8/2014
1002834-103061131	1014904	117601089	11571 RED BARN RD	FAIRHOPE	AL	36532	\$140.85	7/9/2014
1004759-104125411	1013695	117156900	201 SPRING RUN RD #44	FAIRHOPE	AL	36532	\$311.72	7/9/2014
1014365-117326608	1002325	103066538	7850 COUNTY RD 24	FAIRHOPE	AL	36532	\$158.62	7/9/2014
1006523-109046950	1009082	110090659	901 GAYFER AVE APT 511	FAIRHOPE	AL	36532	\$405.72	7/9/2014
1021560-121071518	1011576	115259165	31010 B STANTON RD	SPANISH FORT	AL	36527	\$341.99	7/10/2014
1013574-117090100	1011938	115298704	200 VAN BUREN ST #2110	DAPHNE	AL	36526	\$730.80	7/10/2014
1005091-104102613	1011367	115135533	7118 PARK DR	DAPHNE	AL	36526	\$611.98	7/10/2014
1007514-110016184	1011655	115322693	30928 WATER TOWER RD	SPANISH FORT	AL	36527	\$5.31	7/10/2014
1002918-109057003	1005216	104110021	50 SPRING RUN RD #332	FAIRHOPE	AL	36532	(\$5.86)	7/10/2014
1006604-109057003	1012476	116168500	509 GENERAL GIBSON DR	SPANISH FORT	AL	36527	\$17.77	7/14/2014
1008645-110023793	1005088	104107683	856 APPALOOSA LN	CANTONMENT	FL	32533	\$116.11	7/17/2014
1011330-114024437	1008555	110028479	15050 COUNTY RD 9	SUMMERDALE	AL	36580	\$331.31	7/17/2014
1017783-119257083	1004567	104103528	17320 RIVER RD	SUMMERDALE	AL	36580	\$100.26	7/17/2014
1002566-103061476	1009032	110096744	10337 GAYFER AVE EXT	FAIRHOPE	AL	36532	\$413.08	7/17/2014
1002844-103061230	1005334	104106005	1710 BARKER ST	JASPER	AL	35501	\$11.35	7/18/2014
1019360-119000879	1006333	109020856	135 SAGE LANE	FAIRHOPE	AL	36532	(\$1.63)	7/18/2014
1016972-118012305	1001864	102050209	718 W ORCHID AVE	FOLEY	AL	36535	\$22.69	7/22/2014
1019285-119004813	1021560	121071518	13252 COUNTY RD 1	FAIRHOPE	AL	36532	\$60.56	7/24/2014
1017658-119001310	1002611	103063222	10800 COUNTRY OSTRICH	PENSACOLA	FL	32534	\$20.30	7/24/2014
1007948-110015961	1014371	117325486	20247 RIVER MILL RD	FAIRHOPE	AL	36532	\$24.42	7/25/2014
1018320-119125000	1002160	102052370	314 MAGNOLIA AVE #B (UP)	FAIRHOPE	AL	36532	\$219.79	7/28/2014
1009924-111065495	1009117	110098483	901 GAYFER AVE #723	FAIRHOPE	AL	36532	\$274.75	7/28/2014
1018148-119003925	1019365	119005792	20040 ST HWY 181	FAIRHOPE	AL	36532	\$71.49	7/28/2014
1009301-111006601	1009932	111065871	806 N GREENO RD #21	FAIRHOPE	AL	36532	(\$71.95)	7/29/2014
1016942-118014305	1004955	104106599	14410 BROOK HOLLOW	SUMMERDALE	AL	36580	\$67.34	7/29/2014
1012476-116168500	1001672	102055700	9105 HIGHWAY 98	FAIRHOPE	AL	36532	\$119.55	7/29/2014
1004219-104012500	1013768	117120751	199 SPRINGRUN APT 127	FAIRHOPE	AL	36532	\$467.01	7/30/2014
1014995-117130196	1009048	110091172	901 GAYFER AVE APT 314	FAIRHOPE	AL	36532	\$434.56	7/30/2014
1005973-108125470	1013786	117127461	199 SPRINGRUN APT 137	FAIRHOPE	AL	36532	\$1,004.17	7/30/2014
1002090-102050928	1014918	117125585	901 GAYFER AVE 113	FAIRHOPE	AL	36532	\$521.72	7/30/2014
1013942-117189059	1008320	110014350	8160 COUNTY RD 64 APT 914	DAPHNE	AL	36526	\$463.65	7/31/2014
1018400-119255740	1009106	110096007	PO BOX 721	DAPHNE	AL	36526	\$590.65	7/31/2014
1011655-115322693	1018999	119005811	P O BOX 4910	SPRING	TX	77387	\$109.36	8/1/2014
1013765-117120748	1001721	102046581	10220 HIGHWAY 43 LOT 10	CREOLA	AL	36525	\$17.86	8/1/2014
1008099-110017831	1008126	110026641	21152 MEADOWBROOK DR	FAIRHOPE	AL	36532	\$380.74	8/1/2014
1014945-117130057	1022127	124000050	440 W 21ST ST	NEW YORK	NY	10011	\$18.37	8/1/2014
1011548-115229564	1006869	110026645	PO BOX 1644	FAIRHOPE	AL	36533	\$431.18	8/4/2014
1009920-111452607	1001010	101125473	23437 COUNTY RD 38	SUMMERDALE	AL	36580	\$439.60	8/4/2014
1007808-110018162	1001720	102042171	24160 PINWOOD LANE	ROBERTSDALE	AL	36567	\$31.06	8/4/2014
1006247-109023686	1009923	111065493	806 N GREENO RD #13	FAIRHOPE	AL	36532	\$218.09	8/5/2014
1000877-101065281	1014051	117250502	9175 FAIRHOPE AVE	FAIRHOPE	AL	36532	\$3,019.29	8/5/2014
1022445-124002173	1007205	110047552	715 JOHNSON AVE	FAIRHOPE	AL	36533	\$292.89	8/6/2014
1017692-119236500	1013753	117126580	1901 HWY 190 #323	MANDEVILLE	LA	70448	\$445.37	8/6/2014
1017549-119000969	1015696	117611101	10620 GAYFER RD EXT	FAIRHOPE	AL	36532	\$904.46	8/6/2014
1002074-102050883	1009119	110096305	901 GAYFER AVE APT 724	FAIRHOPE	AL	36532	\$195.22	8/7/2014
1024254-125863254	1002223	102028690	21635 PALMER CT	ROBERTSDALE	AL	36567	\$150.85	8/7/2014

City of Fairhope

Write off Customer Terminated balances as of 6/01/2021

Customer Info	Property ID	Customer ID	Address 1	City	State	Zip Code	Total Unpaid	Stop Date
1004759-104125426	1005364	104100459	29399 LOPER RD	LOXLEY	AL	36551	\$26.96	8/7/2014
1007725-110096602	1013559	117126604	198 AUTUMN DR LOT 8	FAIRHOPE	AL	36532	\$2,310.15	8/8/2014
1004498-104125745	1012001	115312539	13663 CHURCH ST	STAPLETON	AL	36578	\$59.84	8/8/2014
1011070-114026586	1011248	114023677	50 DONNA DR	CALVERTON	NY	11933	\$337.91	8/11/2014
1022172-124000453	1013771	117086503	199 SPRINGRUN APT 129	FAIRHOPE	AL	36532	\$472.06	8/11/2014
1022174-124000454	1004950	104106539	22681 RIVER RD S	DAPHNE	AL	36526	(\$5.96)	8/11/2014
1017987-119567841	1005019	104126618	101 MERIT CIRCLE	GADSDEN	AL	35901	\$14.04	8/12/2014
1012600-116055557	1015082	117130299	811 CRYSTAL WELLS CT	FAIRHOPE	AL	36532	\$323.94	8/12/2014
1001665-102050588	1004674	104104364	16688 COUNTY RD 9	SUMMERDALE	AL	36580	\$127.36	8/12/2014
1006071-109016486	1014947	117138744	105 NORTHCHASE CT	FAIRHOPE	AL	36532	\$407.93	8/12/2014
1004242-104126608	1006159	109026592	6001 WYNDHAM WOODS DR	POWDER SPGS	GA	30127	\$154.88	8/13/2014
1013218-117054875	1001287	102041253	5265 BIG MAPLE CT	TRAVERSE CITY	MI	49684	\$38.79	8/14/2014
1013223-117040264	1022566	124002290	500 SPANISH FORT BVD #114	FAIRHOPE	AL	36532	\$120.95	8/14/2014
1006180-109020731	1009015	110045897	508 ROYSTON LN	MELBOURNE	FL	32940	\$400.15	8/14/2014
1008539-110093056	1001810	102050528	P.O. BOX 7	BON SECOUR	AL	36511	(\$5.96)	8/15/2014
1018692-119002636	1007784	110017416	8132 GAYFER RD EXT #204	FAIRHOPE	AL	36532	\$502.78	8/15/2014
1000420-117625465	1017782	119049606	556 MIDDLE ST	FAIRHOPE	AL	36532	\$110.48	8/19/2014
1002308-103061682	1004779	104125534	16227 JUNIPER LN	SUMMERDALE	AL	36580	\$79.86	8/19/2014
1022339-124513602	1006577	109058406	600 JOHNSON AVE	FAIRHOPE	AL	36532	(\$1.78)	8/20/2014
1005593-106027995	1014679	117350594	12095 CO RD 48	FAIRHOPE	AL	36532	(\$5.96)	8/20/2014
1006537-109056994	1003509	103063070	20888 CR 173	BULLARD	TX	75757	\$67.74	8/21/2014
1000541-122023602	1009958	111017176	813 BON SECOUR	FAIRHOPE	AL	36532	\$2,033.62	8/21/2014
1004433-104155600	1001275	102041031	10915 COUNTY RD 1	FAIRHOPE	AL	36532	\$67.74	8/21/2014
1021646-122004504	1004483	104103002	19425 E RIVER RD N	SILVERHILL	AL	36576	\$229.06	8/21/2014
1015433-117621502	1004497	104125766	23560 ARBOR CREEK DR	ROBERTSDALE	AL	36567	\$112.40	8/25/2014
1000369-113031431	1015060	117130592	701 CRYSTAL WELLS CT N	FAIRHOPE	AL	36532	\$972.33	8/25/2014
1015476-117611134	1009152	110009534	11179 CHEVAL LN	BIRMINGHAM	AL	35216	\$313.91	8/26/2014
1003770-103063282	1007847	110017341	614 SHANNON ST	MOBILE	AL	36610	\$251.20	8/27/2014
1001873-102050184	1010086	111013191	P.O. BOX 1855	FAIRHOPE	AL	36533	\$501.57	8/27/2014
1005297-104110222	1006077	109016762	PO BOX 523	SILVERHILL	AL	36576	\$52.67	8/29/2014
1000459-117305266	1010467	113026591	359 S MOBILE ST UNIT C	FAIRHOPE	AL	36532	\$88.17	8/29/2014
1003509-103063070	1013560	117079221	8207 BAYOU FOUNTAIN	BATON ROUGE	LA	70820	\$170.56	9/2/2014
1005798-108059742	1016248	117610837	866 ROSEDALE RD	ATLANTA	GA	30306	\$50.71	9/2/2014
1015470-117610705	1009001	110089656	214 FARRINGTON	FAIRHOPE	AL	36532	\$496.63	9/2/2014
1009064-110095909	1009282	111028513	9760 TWIN BEECH RD	FAIRHOPE	AL	36532	\$566.97	9/2/2014
1015447-117625485	1005206	104107962	14300 COUNTY RD 28 #A	SUMMERDALE	AL	36580	\$88.94	9/2/2014
1000427-117040715	1009754	111035466	202 SEMINOLE AVE	FAIRHOPE	AL	36532	\$243.77	9/2/2014
1010962-112012006	1003503	103065363	P.O. BOX 182	FAIRHOPE	AL	36533	\$52.83	9/3/2014
1004432-104100370	1013696	117455606	201 SPRINGRUN APT 48	FAIRHOPE	AL	36532	\$527.32	9/3/2014
1011151-114023684	1024305	125869742	9553 ABLE MARLE	DAPHNE	AL	36526	\$39.82	9/5/2014
1006503-109027600	1013800	117458902	7077 TWIN BEECH APT C	FAIRHOPE	AL	36532	\$92.40	9/8/2014
1007048-110017116	1018446	119256405	268 TOMAHAWK CIRCLE	VALLEY GRAND	AL	36701	\$85.29	9/8/2014
1007228-110047879	1012585	116181409	8 RALLY RD	SPANISH FORT	AL	36527	\$62.88	9/9/2014
1018606-119006049	1015456	117611098	P O BOX 1937	FAIRHOPE	AL	36533	\$27.52	9/9/2014
1015636-117610450	1011391	115137850	7499 PINE HILL RD	DAPHNE	AL	36526	\$237.00	9/10/2014
1019036-119254902	1011579	115259116	31040 STANTON RD	SPANISH FORT	AL	36527	\$690.39	9/10/2014
1023838-125890041	1022357	124023014	105 ALSWAY CT	FAIRHOPE	AL	36532	\$153.54	9/10/2014
1015480-117610756	1015758	117659801	20785 LAWRENCE RD	FAIRHOPE	AL	36532	\$176.28	9/11/2014
1010575-113026853	1014633	117345019	20582 A RACHEL MYERS LN	FAIRHOPE	AL	36532	\$72.29	9/11/2014
1009132-110458750	1003233	103065360	803 GRANT ST	BESSEMER	AL	35020	\$14.04	9/11/2014
1000503-120070415	1021014	121458701	703 RICHMOND PL	TUSCALOOSA	AL	35406	\$37.15	9/15/2014
1008182-110025654	1018916	119568786	815 SUMMERLAKE ST	FAIRHOPE	AL	36532	\$151.54	9/15/2014
1017802-119207482	1002189	102050473	PO BOX 1895	FAIRHOPE	AL	36533	\$898.85	9/16/2014
1009483-111026604	1019282	119004811	20765 BISHOP RD 208	FAIRHOPE	AL	36532	\$0.27	9/16/2014
1014616-117327405	1009123	110125518	901 GAYFER AVE APT 726	FAIRHOPE	AL	36532	\$485.50	9/17/2014
1004955-104106599	1001746	102042369	9650 US HWY 98 #30	FAIRHOPE	AL	36532	\$33.33	9/18/2014
1003470-103061581	1008633	110251451	PO BOX 737	FAIRHOPE	AL	36533	\$158.75	9/18/2014
1009257-111056985	1013770	117126555	602 CARROLL ST	BAY MINNETTE	AL	36507	\$253.79	9/19/2014
1009100-110093064	1018456	119256392	8542 GALE ROWE LANE	FAIRHOPE	AL	36532	\$292.89	9/22/2014
1008594-110016787	1013566	117085495	16744 SUGAR LOOP	FOLEY	AL	36535	\$486.97	9/23/2014
1004779-104125534	1002183	102025412	14629 SCENIC HWY 98	FAIRHOPE	AL	36532	\$247.33	9/23/2014
1008571-110235145	1013463	117652155	126 CYPRESS LANE	FAIRHOPE	AL	36532	\$501.17	9/23/2014

City of Fairhope

Write off Customer Terminated balances as of 6/01/2021

Customer Info	Property ID	Customer ID	Address 1	City	State	Zip Code	Total Unpaid	Stop Date
1005022-104106582	1013623	117081138	18 COTTAGE DR	FAIRHOPE	AL	36532	\$282.67	9/24/2014
1016056-117856324	1015454	117611166	PO BOX 40683	MOBILE	AL	36640	\$162.31	9/24/2014
1015925-117045882	1001775	102050988	10090 HWY 98	FAIRHOPE	AL	36532	\$1,384.02	9/25/2014
1005366-104125904	1008961	110099502	13361 LIPSCOMB RD #17	FOLEY	AL	36535	\$400.24	9/26/2014
1019246-119564821	1015590	117625450	355 KNOLLWOOD AVE	FAIRHOPE	AL	36532	\$63.50	9/26/2014
1023955-125930281	1001329	102040274	237 STANFORD AVE	BATON ROUGE	LA	70808	(\$2.50)	9/26/2014
1013582-117090097	1017842	119257023	1407 17TH AVE	STERLING	IL	61081	\$2.42	9/26/2014
1002129-102026533	1009757	111036510	2200 EASTBAY DR #56	DAPHNE	AL	36526	\$186.01	9/29/2014
1000421-117040302	1007783	110017373	469 JOHN ALLEN DRIVE	HUNTSVILLE	TN	37756	\$203.03	9/29/2014
1000475-117376002	1017338	119257164	2473 LOCUS HILL BLVD	BEAVERCREEK	OH	45431	\$18.59	9/29/2014
1016139-117378000	1015433	117610524	10149 MISSION TRACE	FAIRHOPE	AL	36532	\$117.22	9/29/2014
1004936-104106506	1004964	104106365	RIVER ROUTE BOX 125	MAGNOLIA SPG	AL	36555	\$65.52	9/30/2014
1003478-103065228	1017829	119258968	101 DOGWOOD TRAIL	ALABASTER	AL	35007	\$112.68	10/1/2014
1000553-122050343	1001867	102050956	11265 MCKENZIE RD	FAIRHOPE	AL	36532	\$249.98	10/1/2014
1014836-117402388	1021199	121035402	P O BOX 1034	POINT CLEAR	AL	36564	\$50.27	10/1/2014
1014964-117130100	1021459	121086521	5504 WINDMILL DR	MOBILE	AL	36693	\$639.54	10/3/2014
1005334-104106005	1013547	117079137	198 AUTUMN DR #16	FAIRHOPE	AL	36532	\$720.62	10/3/2014
1013231-117045913	1003251	103063205	PO BOX 1092	FAIRHOPE	AL	36533	\$106.18	10/6/2014
1007216-110055416	1013291	117056714	19156 S GREENO RD	FAIRHOPE	AL	36532	\$170.92	10/8/2014
1012921-116181591	1013747	117279600	199 SPRINGRUN RD APT 103	FAIRHOPE	AL	36532	\$265.61	10/8/2014
1006300-109045213	1013377	117099518	19327 S GREENO RD	FAIRHOPE	AL	36532	\$346.94	10/8/2014
1015750-117611061	1013791	117185902	199 SPRINGRUN APT 134	FAIRHOPE	AL	36532	\$907.93	10/8/2014
1005462-105014738	1013748	117120750	199 SPRINGRUN DR APT 104	FAIRHOPE	AL	36532	\$332.80	10/8/2014
1004335-104100501	1006734	110017990	765 NORTHPROP	FAIRHOPE	AL	36532	\$1,025.32	10/8/2014
1014918-117125551	1008754	110065804	1706 BERKSHIRE LANE	STATESBORO	GA	30461	\$802.38	10/10/2014
1015194-117652491	1013705	117125601	201 SPRINGRUN APT 50	FAIRHOPE	AL	36532	\$497.92	10/13/2014
1018078-119548704	1009920	111452604	1302 OAK ST	DAPHNE	AL	36526	\$1,107.17	10/14/2014
1013781-117126469	1013784	117125578	199 SPRINGRUN APT 135	FAIRHOPE	AL	36532	\$221.19	10/14/2014
1014817-117402600	1009183	110092785	901 GAYFER AVE APT 1114	FAIRHOPE	AL	36532	\$350.09	10/15/2014
1003251-103063205	1007100	110022655	23 BAYWALK CT	GULF SHORES	AL	36542	\$461.74	10/15/2014
1022111-124125721	1010668	113032560	556 KUMQUAT ST	FAIRHOPE	AL	36532	\$110.53	10/15/2014
1003475-103063036	1005696	107045261	PO BOX 551	MAGNOLIA SPG	AL	36555	\$63.32	10/15/2014
1000571-124080500	1003756	103456980	12144 MEADOW RD LOT B	FAIRHOPE	AL	36532	\$105.03	10/16/2014
1012091-115398011	1004262	104256911	8945 RIDGEMONT DR	ATLANTA	GA	30350	\$227.07	10/17/2014
1007231-110052703	1015698	117621542	10672 GAYFER RD EXT	FAIRHOPE	AL	36532	\$138.71	10/17/2014
1005340-104100497	1006106	109016528	3320 PLANTATION TRACE	MILTON	GA	30004	\$109.04	10/17/2014
1000217-107125402	1005312	104125535	15651 CO RD 49	SUMMERDALE	AL	36580	\$1,046.90	10/20/2014
1005341-104152696	1014846	117857404	19027 COUNTY RD 33 LOT 2	FAIRHOPE	AL	36532	\$14.04	10/21/2014
1002611-103063302	1013222	117040886	9556 COUNTY RD 34 LOT 15	FAIRHOPE	AL	36532	\$96.84	10/22/2014
1009123-110125524	1019202	119005047	19655 STATE HWY 181	FAIRHOPE	AL	36532	\$77.89	10/22/2014
1008969-110024009	1005329	104154801	9299 SURREY DR	PENSACOLA	FL	32534	\$168.23	10/23/2014
1013233-117040922	1006856	110452303	801 FAIRHOPE AVE	FAIRHOPE	AL	36532	\$870.85	10/24/2014
1008080-110017647	1013681	117854720	201 SPRINGRUN APT 32	FAIRHOPE	AL	36532	\$349.96	10/27/2014
1006023-109011319	1005577	106253903	15461 RIVER RD	FAIRHOPE	AL	36532	\$420.75	10/28/2014
1018426-119003832	1003720	103065463	15439 SUN RAY CT	FOLEY	AL	36535	\$137.10	10/28/2014
1006896-110018959	1014991	117130614	864 WERHLE DR	BUFFALO	NY	14221	\$415.25	10/30/2014
1008559-110023865	1009921	111075500	806 N GREENO RD LOT 11	FAIRHOPE	AL	36532	\$764.56	10/30/2014
1009013-110096780	1004156	104001535	7659 AUDUBON DR	FOLEY	AL	36535	\$216.72	10/31/2014
1003227-103063285	1005964	108026607	254 GEORGE ST	FAIRHOPE	AL	36532	\$735.58	10/31/2014
1015568-117610973	1015442	117610452	PO BOX 1590	FAIRHOPE	AL	36533	\$59.66	10/31/2014
1010792-113056900	1004433	104155604	19138 MEADOW DOVE LN #19	SILVERHILL	AL	36576	\$8.78	10/31/2014
1009928-111067688	1009310	111008508	15455 WRANGLER RD	SUMMERDALE	AL	36580	\$1,038.22	10/31/2014
1016758-117042129	1001665	102050139	8862 US HWY 98	FAIRHOPE	AL	36532	\$185.03	10/31/2014
1013216-117040941	1006023	109011319	500 JACKSON ST APT 501	DAPHNE	AL	36526	\$69.99	11/3/2014
1010925-114026601	1009912	111066590	806 N GREENO RD LOT 2	FAIRHOPE	AL	36532	\$752.83	11/3/2014
1004272-104521460	1018526	119001788	8115 TWIN BEECH RD	FAIRHOPE	AL	36532	(\$0.70)	11/3/2014
1009913-111037456	1014945	117130057	710 LAUREL AVE	FOLEY	AL	36535	\$898.20	11/4/2014
1011529-115191013	1013515	117080181	198 AUTUMN DR LOT 39	FAIRHOPE	AL	36532	\$559.88	11/5/2014
1008108-110095883	1017806	119257100	7684 TWIN BEECH RD #607	FAIRHOPE	AL	36532	\$178.68	11/6/2014
1009117-110098498	1004324	104152631	PO BOX 369	BAY MINETTE	AL	36507	(\$0.70)	11/6/2014
1006257-109026862	1007216	110055416	1960 SUN HILL RD SW	CLEVELAND	TN	37311	\$1,182.16	11/6/2014
1008641-110125493	1013225	117610959	P O BOX 7132	SPANISH FORT	AL	36577	\$105.00	11/6/2014

City of Fairhope

Write off Customer Terminated balances as of 6/01/2021

Customer Info	Property ID	Customer ID	Address 1	City	State	Zip Code	Total Unpaid	Stop Date
1009099-110096687	1005207	<u>104125626</u>	14300 COUNTY RD 28 #8	SUMMERDALE	AL	36580	\$78.95	11/7/2014
1013771-117086503	1008106	<u>110017839</u>	21157 MEADOW BROOK DR	FAIRHOPE	AL	36532	\$59.97	11/10/2014
1017842-119256948	1013561	<u>117086549</u>	2133 HURSTVIEW DR	HURST	TX	76054	\$336.74	11/10/2014
1004864-104106625	1013548	<u>117079082</u>	198 AUTUMN DR LOT 15	FAIRHOPE	AL	36532	\$741.21	11/10/2014
1007102-110036521	1017846	<u>119259806</u>	7684 TWIN BEECH RD #206	FAIRHOPE	AL	36532	\$206.63	11/10/2014
1005374-104125913	1012070	<u>115370401</u>	35660 DAVISON LN	STAPLETON	AL	36578	\$15.86	11/10/2014
1014633-117345019	1021747	<u>122050276</u>	2050 BRADBURY DR E	MOBILE	AL	36695	(\$5.96)	11/12/2014
1001744-102042364	1021975	<u>123156900</u>	109 WINDSOR DR	DAPHNE	AL	36526	\$50.86	11/12/2014
1002189-102050473	1012659	<u>116182503</u>	41115 STATE HWY 225	BAY MINETTE	AL	36507	\$32.44	11/12/2014
1018286-119213608	1018987	<u>119256965</u>	18101 SCENIC HWY 98	FAIRHOPE	AL	36532	\$103.69	11/12/2014
1021968-123152303	1021721	<u>122050147</u>	PO BOX 1434	POINT CLEAR	AL	36564	\$41.98	11/17/2014
1009487-111025627	1018531	<u>119567804</u>	19121 BOOTHE RD	FAIRHOPE	AL	36532	\$188.21	11/17/2014
1006475-109026828	1009915	<u>111075845</u>	31221 TURBERVILLE LN	SPANISH FORT	AL	36527	\$452.28	11/18/2014
1009910-111065211	1017795	<u>119254858</u>	1006 SEA CLIFF DR N	DAPHNE	AL	36526	\$41.50	11/19/2014
1005675-107049560	1010125	<u>111025468</u>	9 CANEBREAK PL	FAIRHOPE	AL	36532	(\$9.08)	11/19/2014
1009073-110452131	1011370	<u>115135529</u>	PO BOX 154	DAPHNE	AL	36526	\$19.80	11/19/2014
1013568-117089501	1019133	<u>119259605</u>	18818 FOUNDERS DR	FAIRHOPE	AL	36532	\$71.58	11/20/2014
1016425-117785503	1009340	<u>111026617</u>	414 GRAND AVE	FAIRHOPE	AL	36532	\$1,353.90	11/21/2014
1001554-102055718	1011996	<u>115314503</u>	35350 PINE RD S	STAPLETON	AL	36578	\$43.49	11/21/2014
1018654-119002352	1013694	<u>117126506</u>	1202 LOWER ST	BAY MINETTE	AL	36537	\$310.88	11/21/2014
1006206-109025738	1013553	<u>117085604</u>	558 SOUTHERN RUN	FAIRHOPE	AL	36532	\$794.82	11/24/2014
1023122-124002221	1013655	<u>117854785</u>	201 SPRINGRUN APT 23	FAIRHOPE	AL	36532	\$103.33	11/26/2014
1010712-113035415	1019165	<u>119005541</u>	2185 ROBERTS DR N	MT VERNON	AL	36560	\$97.82	12/1/2014
1017856-119256951	1012203	<u>116002001</u>	P.O. BOX 3175	DAPHNE	AL	36526	(\$76.76)	12/1/2014
1003685-103064054	1013525	<u>117079133</u>	198 AUTUMN DR #31	FAIRHOPE	AL	36532	\$788.42	12/2/2014
1005147-104102361	1013950	<u>117186902</u>	14 BURLINGTON DR	FAIRHOPE	AL	36532	\$925.52	12/2/2014
1015201-117620085	1002329	<u>103065460</u>	7792 COUNTY RD 24	FAIRHOPE	AL	36532	\$105.90	12/2/2014
1001234-102040371	1013811	<u>117120742</u>	394 S INGLESIDE	FAIRHOPE	AL	36532	\$47.01	12/2/2014
1008647-110036526	1015491	<u>117610553</u>	21310 HWY 181 #19	FAIRHOPE	AL	36532	\$101.23	12/2/2014
1005718-107452894	1013234	<u>117045706</u>	P O BOX 55	SUMMERDALE	AL	36580	\$157.34	12/3/2014
1017554-119000961	1007806	<u>110017407</u>	8 S BANCROFT	FAIRHOPE	AL	36532	\$522.77	12/4/2014
1024217-125314602	1007205	<u>110047553</u>	PO BOX 2172	FOLEY	AL	36536	\$344.77	12/5/2014
1004262-104256921	1006605	<u>109056995</u>	705 BUTTERCUP DR	GRIFFIN	GA	30223	\$106.54	12/5/2014
1016410-117785480	1017204	<u>119000261</u>	1103 W LAUREL AVE APT F	FOLEY	AL	36535	\$409.47	12/8/2014
1009121-110095940	1018067	<u>119254756</u>	9040 MORPHY AVE LOT 6	FAIRHOPE	AL	36532	\$261.29	12/8/2014
1012561-116191908	1003503	<u>103065374</u>	PO BOX 165	MAGNOLIA SPRG	AL	36555	\$58.09	12/8/2014
1017060-118103701	1013657	<u>117854806</u>	201 SPRING RUN #19	FAIRHOPE	AL	36532	\$469.96	12/8/2014
1021184-121030730	1008574	<u>110025520</u>	16693 PLUM CT	LOXLEY	AL	36551	\$177.84	12/8/2014
1003976-103061544	1012537	<u>116123002</u>	9643 SADDLEBROOK DR S	MOBILE	AL	36695	\$84.62	12/8/2014
1017717-119000718	1021044	<u>121045877</u>	PO BOX 1141	FAIRHOPE	AL	36533	\$434.06	12/8/2014
1005352-104106534	1000401	<u>115298742</u>	32141 BUZBEE RD	SPANISH FORT	AL	36527	\$161.42	12/8/2014
1004759-104125424	1014365	<u>117326605</u>	20319 RIVER MILL DR	FAIRHOPE	AL	36532	\$101.40	12/10/2014
1000408-115362000	1009312	<u>111025441</u>	601 GAYFER AVE	FAIRHOPE	AL	36532	\$550.09	12/10/2014
1017289-119001419	1018631	<u>119569836</u>	4310 LAUDER LANE	ORANGE BEACH	AL	36561	\$577.65	12/10/2014
1016758-117042195	1000465	<u>117620012</u>	2118 BELLWOOD DR	NORTHPORT	AL	35476	(\$1.63)	12/10/2014
1007222-110025809	1006034	<u>109058744</u>	302 S SCHOOL ST	FAIRHOPE	AL	36532	\$1,005.35	12/10/2014
1018280-119002583	1011600	<u>115021543</u>	26229 WALKER S RD LOT 38	DENHAM SPGS	LA	70726	\$215.93	12/10/2014
1013553-117079120	1013721	<u>117126625</u>	1155 SOUTH ANN ST	MOBILE	AL	36605	\$27.11	12/10/2014
1015060-117130592	1018286	<u>119213608</u>	9808 EVENSTON ST	DAPHNE	AL	36526	(\$9.08)	12/12/2014
1009022-110045908	1005036	<u>104106703</u>	P O BOX 912	MAGNOLIA SPGS	AL	36555	\$150.25	12/15/2014
1014420-117325502	1008070	<u>110025850</u>	20969 BISHOP RD #2	FAIRHOPE	AL	36532	\$479.93	12/16/2014
1003672-103066521	1009617	<u>111045882</u>	108 TOMRICK CIR	DAPHNE	AL	36526	\$216.09	12/17/2014
1006475-109026830	1017687	<u>119001380</u>	18957 BRACEY LN	FAIRHOPE	AL	36532	\$90.75	12/17/2014
1006068-109021379	1006523	<u>109046952</u>	305 YOUNG ST	FAIRHOPE	AL	36532	\$553.84	12/18/2014
1009172-110092286	1005357	<u>104100209</u>	15871 RED STAR DR LOT 21	SUMMERDALE	AL	36580	\$155.56	12/19/2014
1009941-111076426	1009394	<u>111013546</u>	410 BARCLAY AVENUE	FAIRHOPE	AL	36532	\$106.31	12/23/2014
1006020-109057000	1009151	<u>110095846</u>	12375 NANWOOD DR	FOLEY	AL	36535	\$450.35	12/23/2014
1008080-110017940	1009132	<u>110458750</u>	901 GAYFER AVE #718	FAIRHOPE	AL	36532	\$646.79	12/29/2014
1022320-124021562	1005332	<u>104106522</u>	PO BOX 1100	POINT CLEAR	AL	36564	\$17.54	12/29/2014
1013510-117080714	1012001	<u>115312563</u>	51 CLUBHOUSE DR	ROCKY PT	NY	11778	\$34.54	12/29/2014
1000053-102049980	1009610	<u>111044513</u>	307 GAYFER CT #A	FAIRHOPE	AL	36532	\$2,566.78	12/29/2014
1013292-117452136	1005827	<u>108012544</u>	250 LIBERTY ST	FAIRHOPE	AL	36532	\$145.26	12/31/2014

City of Fairhope

Write off Customer Terminated balances as of 6/01/2021

Customer Info	Property ID	Customer ID	Address 1	City	State	Zip Code	Total Unpaid	Stop Date
1001763-102046987	1013223	117040872	9556 COUNTY RD 34 #16	FAIRHOPE	AL	36532	\$42.97	12/31/2014
1009373-111014136	1006537	109056997	105 1/2 MERSHON	FAIRHOPE	AL	36532	\$586.55	1/2/2015
1009825-111048514	1001479	102042203	PO BOX 1592	FAIRHOPE	AL	36533	(\$5.96)	1/2/2015
1003331-103065334	1006538	109065497	8391 ROCKWELL LN	FAIRHOPE	AL	36532	\$738.02	1/2/2015
1006892-110018919	1011271	114028472	312 LIBERTY ST	FAIRHOPE	AL	36532	\$396.13	1/5/2015
1018983-119199977	1011151	114023684	PO BOX 721	FAIRHOPE	AL	36533	\$220.33	1/6/2015
1013425-117066252	1004864	104106625	14360 COUNTY RD 9	FOLEY	AL	36535	\$180.61	1/6/2015
1009028-110097477	1013843	117458705	950 SPRINGRUN APT 17	FAIRHOPE	AL	36532	\$70.42	1/7/2015
1014414-117305189	1004277	104526990	3621 VISTA RIDGE DR W	MOBILE	AL	36693	\$478.63	1/8/2015
1004700-104105239	1011384	115135534	P O BOX 7502	SPANISH FT	AL	36577	\$128.84	1/8/2015
1009909-111065261	1012311	116100315	1102 NORTHSORE DR	BAY MINETTE	AL	36507	\$102.95	1/8/2015
1008645-110025665	1023305	124002980	4301 THE CEDARS AVE	MOBILE	AL	36609	(\$9.08)	1/8/2015
1017846-119259806	1006572	109042400	9700 COURTEIGH CIRCLE	AUSTIN	TX	78759	\$235.47	1/12/2015
1011996-115314503	1003496	103015960	1809 9TH ST N	CLANTON	AL	35045	\$212.69	1/13/2015
1021442-121082500	1002834	103061131	10055 WOODMERE DR	FAIRHOPE	AL	36532	\$96.11	1/15/2015
1009096-110025919	1001921	102050571	1729 TOULOUSE LANE	FOLEY	AL	36535	\$2.69	1/16/2015
1009912-111066590	1002174	102054121	19 N CHURCH ST #D	FAIRHOPE	AL	36532	\$123.67	1/16/2015
1009100-110085700	1002176	102054602	19 N CHURCH ST #C	FAIRHOPE	AL	36532	\$149.63	1/16/2015
1009200-110025455	1001752	102046514	9650 US HWY 98 #17	FAIRHOPE	AL	36532	\$165.73	1/20/2015
1002769-103652825	1005340	104100458	PO BOX 1424	ROBERTSDALE	AL	36567	\$8.78	1/20/2015
1009080-110095471	1008866	110065878	22080 9TH ST	SILVERHILL	AL	36576	\$1,672.49	1/20/2015
1013694-117126506	1009145	110092795	800 BANKHEAD BLVD	TALLEDEGA	AL	35160	\$689.80	1/21/2015
1001679-102050536	1009366	111237454	406 MILLER AVENUE	FAIRHOPE	AL	36532	\$676.89	1/22/2015
1010364-112046909	1005341	104152695	15840 RED STAR DR LOT 12	SUMMERDALE	AL	36580	\$101.83	1/22/2015
1015447-117625513	1009171	110097495	21796 SANDY SPRINGS CIR	ROBERTSDALE	AL	36567	\$967.57	1/22/2015
1005776-107014720	1009182	110964006	901 GAYFER AVE APT 1124	FAIRHOPE	AL	36532	\$289.94	1/23/2015
1015757-117611281	1008940	110068451	903 EDWARDS AVE A	FAIRHOPE	AL	36532	\$490.34	1/26/2015
1009919-111025527	1015476	117611048	21400 STATE HWY 181 #10	FAIRHOPE	AL	36532	\$11.35	1/27/2015
1001756-102047501	1013518	117080111	P O BOX 685	DAPHNE	AL	36526	\$1,009.21	1/30/2015
1006083-109016499	1016108	117375161	401 RADDISON RD	MARQUETTE HT	IL	61554	(\$5.96)	1/30/2015
1004978-104107854	1003773	103626903	12144 MEADOW RD #27	FAIRHOPE	AL	36532	\$157.00	1/30/2015
1001349-102056489	1009825	111048500	850 HANCOCK RD	FAIRHOPE	AL	36532	\$439.56	1/30/2015
1014906-117090504	1005846	108025473	153 WHITE AVE	FAIRHOPE	AL	36532	\$40.85	1/30/2015
1017774-119254636	1013943	117189070	20675 LOWRY DRIVE	FAIRHOPE	AL	36532	\$375.69	2/2/2015
1010110-111017586	1008961	110099503	210 LEE ST	FAIRHOPE	AL	36532	\$1,396.02	2/2/2015
1023275-124200000	1014873	117400053	PO BOX 738	FAIRHOPE	AL	36533	\$2.69	2/2/2015
1012454-116125400	1005361	104102658	15931 RED STAR DR LOT 26	SUMMERDALE	AL	36580	\$111.96	2/2/2015
1016248-117610837	1009922	111258603	PO BOX 164	MONTROSE	AL	36559	\$65.55	2/3/2015
1012510-116180601	1013333	117058470	19270 S GREENO RD LOT 48	FAIRHOPE	AL	36532	\$203.61	2/3/2015
1006231-109026593	1017747	119855602	372 YOUNG ST	FAIRHOPE	AL	36532	\$107.20	2/4/2015
1015442-117610452	1003472	103075422	14099 COUNTY RD 13	FAIRHOPE	AL	36532	\$139.99	2/6/2015
1018529-119574808	1009100	110093064	901 GAYFER AVE APT 623	FAIRHOPE	AL	36532	\$997.04	2/6/2015
1009167-110098785	1005366	104125903	15972 BROOK WAY #32	SUMMERDALE	AL	36580	\$65.90	2/6/2015
1018677-119003791	1005329	104154802	15972 RED STAR DR #1	SUMMERDALE	AL	36580	\$71.89	2/6/2015
1009348-111011455	1023838	125890040	9765 SOMMERSET DR	DAPHNE	AL	36526	\$150.06	2/8/2015
1008549-110018097	1016394	117782335	706 RIVER RD	FORT LAWN	SC	29714	\$107.36	2/9/2015
1003737-103061234	1017105	119257408	18664 TWIN BEECH RD S	FAIRHOPE	AL	36532	\$113.04	2/9/2015
1005364-104200495	1000854	101055315	PO BOX 1848	FAIRHOPE	AL	36533	\$97.64	2/9/2015
1009143-110095781	1021007	121055694	PO BOX 711	POINT CLEAR	AL	36564	\$131.35	2/10/2015
1004074-103063074	1013272	117040786	163 STATE ST APT B	MOBILE	AL	36603	\$50.84	2/11/2015
1009140-110095428	1001668	102052057	13405 CHRIS HIRES RD	FAIRHOPE	AL	36532	\$95.71	2/11/2015
1008754-110065804	1017658	119001310	7605 TWIN BEECH RD	FAIRHOPE	AL	36532	\$303.11	2/12/2015
1016394-117782335	1006203	109452600	13962A MILLER LN	SUMMERDALE	AL	36580	\$154.53	2/12/2015
1009923-111065493	1016676	117046925	405 COLLINWOOD LOOP	FOLEY	AL	36535	\$244.34	2/13/2015
1012339-116070504	1006181	109058208	27270 PARKER LN	DAPHNE	AL	36526	\$667.63	2/16/2015
1012311-116100315	1024344	125930088	1406 H ST	AURORA	NE	68818	\$64.64	2/16/2015
1019125-119006061	1009073	110452142	901 GAYFER AVE APT 426	FAIRHOPE	AL	36532	\$623.33	2/18/2015
1003233-103065360	1001741	102042316	9650 US HWY 98 #26	FAIRHOPE	AL	36532	\$128.63	2/20/2015
1023226-124125478	1015433	117621502	2301 LOCKE LN	DAPHNE	AL	36526	\$17.86	2/23/2015
1017551-119001002	1009022	110045908	901 GAYFER AVE APT 112	FAIRHOPE	AL	36532	\$586.05	2/23/2015
1005200-104107903	1000999	101109052	50 S CHURCH ST #14	FAIRHOPE	AL	36532	\$323.68	2/23/2015
1001661-102050937	1018601	119002322	50 SPRING RUN DR APT 204	FAIRHOPE	AL	36532	(\$9.63)	2/24/2015

City of Fairhope

Write off Customer Terminated balances as of 6/01/2021

Customer Info	Property ID	Customer ID	Address 1	City	State	Zip Code	Total Unpaid	Stop Date
1009134-110074580	1005362	104106651	15943 RED STAR DR #27	SUMMERDALE	AL	36580	\$176.67	2/26/2015
1001611-102050947	1002844	103061230	17599 WOODMERE COURT	FAIRHOPE	AL	36532	\$280.68	2/27/2015
1003174-103061355	1008645	110025665	796 9TH AVE #6	NEW YORK	NY	10019	\$14.42	2/27/2015
1007279-110095866	1013222	117040897	P O BOX 21	SUMMERDALE	AL	36580	\$8.78	2/27/2015
1021795-122050352	1018664	119066537	105 WINDSOR COURT	DAPHNE	AL	36526	\$217.06	2/27/2015
1021689-122050039	1017484	119001321	PO BOX 1177	FAIRHOPE	AL	36533	\$172.69	3/2/2015
1000327-110014338	1005346	104100238	15796 RED STAR DR LOT 45	SUMMERDALE	AL	36580	\$156.38	3/2/2015
1013234-117045709	1013531	117856908	PO BOX 513	MONTROSE	AL	36559	\$1,983.76	3/2/2015
1013559-117126605	1005208	104107957	14554 COUNTRY LIVING LN	SUMMERDALE	AL	36580	\$153.81	3/3/2015
1017973-119524697	1006733	110017999	4123 AUGUSTA DR	GULF SHORES	AL	36542	\$81.00	3/3/2015
1006703-117135406	1022192	124000776	2868 ACTON RD	BIRMINGHAM	AL	35243	\$27.00	3/5/2015
1016403-117784755	1015974	117045936	119 LIVE OAK DR	NATCHEZ	MS	39120	\$164.52	3/6/2015
1013222-117040927	1011518	115254601	10051 FOX RUN ROAD	PENSACOLA	FL	32514	\$525.52	3/9/2015
1000850-101059620	1012233	116036506	3 CONFEDERATE DRIVE	SPANISH FORT	AL	36527	\$480.50	3/9/2015
1008180-110020769	1006333	109020858	19328 CEDAR LN	FAIRHOPE	AL	36532	(\$1.35)	3/9/2015
1009137-110096551	1019186	119005045	5065 BEATLINE RD	LONG BEACH	MS	39560	\$28.78	3/10/2015
1000109-103060787	1013516	117126626	198 AUTUMN DR LOT 38	FAIRHOPE	AL	36532	\$866.92	3/11/2015
1009029-110095891	1001674	102041180	9111 US HWY 98	FAIRHOPE	AL	36532	\$138.89	3/12/2015
1005366-104125903	1017216	119001044	133 N FRIENDSWOOD DR #247	FRIENDWOOD	TX	77546	(\$5.96)	3/12/2015
1019248-119004688	1022445	124002173	31199 BUCKINGHAM BLVD	SPANISH FORT	AL	36527	(\$0.55)	3/13/2015
1018834-119564879	1007626	110025913	103 HOMESTEAD APT 11	FAIRHOPE	AL	36532	\$399.04	3/13/2015
1012948-116600494	1012293	116625412	107 SPANISH MAIN	SPANISH FORT	AL	36527	\$123.40	3/17/2015
1016046-117856163	1003999	103008359	621 FAIRHOPE AVE	FAIRHOPE	AL	36532	\$875.77	3/18/2015
1002611-103063222	1004278	104006565	210 FAIRHOPE AVE #B	FAIRHOPE	AL	36532	\$539.72	3/18/2015
1005124-104102508	1021254	121085477	2033 BRIARWOOD ST	PRATTVILLE	AL	36066	\$217.82	3/19/2015
1006601-109065483	1006951	110027454	663 MARCA CT	FAIRHOPE	AL	36532	\$37.07	3/19/2015
1006554-109055427	1010853	114006000	355 S CHURCH ST	FAIRHOPE	AL	36532	\$1,358.26	3/19/2015
1018085-119564231	1001162	101061033	14 TWIN ECHO CT B	FAIRHOPE	AL	36532	\$711.48	3/19/2015
1004684-104104407	1014753	117375092	1484 MEADOW GLENN LN	ROCKHILL	SC	29730	(\$5.96)	3/20/2015
1001775-102050958	1008080	110017647	9759 TX HWY 11	HUGH SPRGS	TX	75656	\$36.83	3/24/2015
1006825-110053823	1009251	111007028	819 BAY CLIFF RD	GULF BREEZE	FL	32561	\$367.87	3/24/2015
1008091-110090373	1022841	124056390	104 OAK BEND CT	FAIRHOPE	AL	36532	\$224.39	3/25/2015
1002098-102057029	1010575	113026853	26 ORANGE AVE	FAIRHOPE	AL	36532	\$893.64	3/26/2015
1008555-110028479	1007056	110016992	100 INGLESIDE TERRACE CIR	FAIRHOPE	AL	36532	\$396.51	3/26/2015
1015590-117625450	1003323	103063228	9803 SILVERWOOD DR	FAIRHOPE	AL	36532	\$94.62	3/27/2015
1008981-110098749	1024051	125000613	909 VAN AVE	DAPHNE	AL	36526	\$52.27	3/30/2015
1005110-104107501	1006744	110125464	754 NORTHROP AVE	FAIRHOPE	AL	36532	\$337.62	3/30/2015
1011250-114023682	1013912	117265805	860 GRANGEVILLE BLVD#22	HANFORD	CA	93230	\$113.59	3/30/2015
1014961-117130553	1004073	103085694	PO BOX 2034	FAIRHOPE	AL	36533	\$392.62	3/31/2015
1014873-117400053	1013559	117126605	198 AUTUMN DR LOT 21	FAIRHOPE	AL	36532	\$916.57	3/31/2015
1002115-102055608	1011912	115312578	30167 GREEN CT	DAPHNE	AL	36526	\$146.19	3/31/2015
1018040-119003782	1018637	119004340	1505 MOOG AVE	BAY MINETTE	AL	36507	\$609.54	3/31/2015
1005017-104106313	1010712	113035415	156 LAUREL AVE	FAIRHOPE	AL	36532	\$403.87	4/1/2015
1015756-117625390	1009171	110097502	200 BELL HOPPER	KENNETT	MO	63857	\$176.00	4/1/2015
1012086-115313136	1021035	121004560	PO BOX 1268	POINT CLEAR	AL	36564	\$26.59	4/1/2015
1007231-110052700	1005301	104152877	15591 COUNTY RD 49 #4	SUMMERDALE	AL	36585	\$150.80	4/2/2015
1015442-117610475	1009922	111258606	14251 S HWY 104 LOT 38	SILVERHILL	AL	36576	\$33.08	4/3/2015
1021014-121458701	1005582	106023672	436 RIDGEWOOD DR	DAPHNE	AL	36526	\$459.63	4/6/2015
1005635-107019027	1013498	117065801	PO BOX 786	FAIRHOPE	AL	36533	\$111.96	4/6/2015
1001749-102042385	1006802	110010407	100 N BANCROFT ST APT C1	FAIRHOPE	AL	36532	\$689.11	4/7/2015
1009901-110089656	1017554	119000951	17010 S SECTION ST	FAIRHOPE	AL	36532	\$1,449.46	4/7/2015
1013655-117854789	1015477	117626513	21400 STATE HWY 181 LOT 8	FAIRHOPE	AL	36532	\$94.60	4/8/2015
1002817-103065341	1001420	102040399	P.O. BOX 1932	FAIRHOPE	AL	36533	\$64.41	4/9/2015
1015755-117659802	1017289	119001419	26124 PERDIDO BH BLVD#6	ORANGE BEACH	AL	36561	(\$5.96)	4/9/2015
1015500-117611208	1021254	121085478	PO BOX 81	FAIRHOPE	AL	36533	\$35.26	4/9/2015
1012509-116182542	1014692	117350654	300 FAULKNER DR	BAY MINETTE	AL	36507	\$185.88	4/10/2015
1015973-117040876	1007232	110047974	1203 US HWY 98 SUITE 4C	DAPHNE	AL	36526	\$164.15	4/10/2015
1006181-109058208	1001756	102047500	9650 US HWY 98 LOT 13	FAIRHOPE	AL	36532	\$93.50	4/10/2015
1013377-117099518	1024019	125256982	9141 COUNTY RD 64	DAPHNE	AL	36526	\$194.21	4/13/2015
1006191-109021504	1004021	103011019	412 FAIRHOPE AVE	FAIRHOPE	AL	36532	\$97.28	4/13/2015
1001417-102050529	1022197	124000775	2868 ACTON RD	BIRMINGHAM	AL	35243	\$211.92	4/14/2015
1009491-111026521	1006149	109016735	11309 PATCH LANE	FAIRHOPE	AL	36532	\$99.32	4/14/2015

City of Fairhope

Write off Customer Terminated balances as of 6/01/2021

Customer Info	Property ID	Customer ID	Address 1	City	State	Zip Code	Total Unpaid	Stop Date
1009483-111026619	1011633	115285615	PO BOX 7192	SPANISH FORT	AL	36577	\$21.14	4/14/2015
1022846-124569830	1015647	117254726	20637 BLUEBERRY LANE #8	FAIRHOPE	AL	36532	\$69.39	4/16/2015
1009182-110964000	1021039	121015800	P O BOX 563	POINT CLEAR	AL	36564	\$525.82	4/16/2015
1009380-111014332	1009483	111026619	513 VOLANTA AVE	FAIRHOPE	AL	36532	\$504.25	4/17/2015
1009282-111028513	1013510	117080716	9650 HWY 98 #8	FAIRHOPE	AL	36532	\$517.99	4/20/2015
1021984-123156016	1003174	103061358	9650 US HWY 98 LOT 10	FAIRHOPE	AL	36532	\$20.00	4/20/2015
1013406-117066190	1020526	120047609	PO BOX 657	FAIRHOPE	AL	36533	\$190.33	4/20/2015
1017402-119006546	1006068	109021375	PO BOX 27	FAIRHOPE	AL	36533	\$981.35	4/21/2015
1018686-119257133	1012026	115343114	13889 STYX RIVER RD	STAPLETON	AL	36578	\$14.72	4/22/2015
1015475-117622505	1009107	110458754	PO BOX 804	SUMMERDALE	AL	36580	\$404.90	4/27/2015
1009097-110023802	1006892	110018919	1320 BUENA VISTA BLVD	PANAMA CITY	FL	32401	\$510.45	4/27/2015
1004978-104106619	1008536	110018126	21081 BISHOP RD APT 1	FAIRHOPE	AL	36532	\$905.83	4/29/2015
1004700-104105243	1023155	124002297	PO BOX 216	MONTROSE	AL	36559	\$50.19	4/29/2015
1005329-104154802	1023154	124002298	PO BOX 216	MONTROSE	AL	36559	\$10.92	4/29/2015
1009134-110047583	1015476	117611134	21400 US HWY 181 LOT 10	FAIRHOPE	AL	36532	\$93.29	5/1/2015
1001273-102045886	1003173	103065516	9650 US HWY 98 LOT 10	FAIRHOPE	AL	36532	\$125.19	5/4/2015
1011912-115312578	1015475	117622502	21400 COUNTY RD 27 LOT 12	FAIRHOPE	AL	36532	\$232.11	5/4/2015
1014422-117325729	1013929	117104508	114 SPRING PARK DR	FAIRHOPE	AL	36532	\$493.89	5/4/2015
1013692-117458805	1013234	117045707	9556 COUNTY RD 34 LOT 4	FAIRHOPE	AL	36532	\$361.91	5/6/2015
1001526-102042322	1013756	117125485	199 SPRINGRUN APT 124	FAIRHOPE	AL	36532	\$476.41	5/7/2015
1014343-117325635	1004623	104126906	PO BOX 5089	GULF SHORES	AL	36547	\$250.94	5/7/2015
1001056-101088008	1014780	117425695	257 HEMINGWAY LOOP	FOLEY	AL	36535	(\$6.53)	5/8/2015
1001752-102046514	1002356	103066580	14632 GREENO RD #C	FAIRHOPE	AL	36532	\$110.45	5/8/2015
1003729-103061538	1016345	117745891	9697 CAMBERWELL DR	FAIRHOPE	AL	36532	\$45.78	5/11/2015
1008941-110095834	1002115	102055608	8680 S PROVIDENCE DR	NINEVEH	IN	46164	\$13.33	5/11/2015
1013214-117040862	1016216	117611215	3009 IRA YOUNG DRIVE	TEMPLE	TX	76504	\$45.67	5/11/2015
1013947-117189531	1017123	119000328	PO BOX 24	FAIRHOPE	AL	36533	\$248.81	5/12/2015
1009183-110092830	1015755	117659803	402 MELBOURNE DR	ENTERPRISE	AL	36330	\$200.70	5/12/2015
1013759-117126636	1018915	119569820	9980 BAY MEADOWS RD	FAIRHOPE	AL	36532	\$73.39	5/12/2015
1009099-110096711	1013230	117040284	9556 COUNTY RD 34 #1	FAIRHOPE	AL	36532	\$96.38	5/14/2015
1015698-117621542	1020974	120068564	19270 SCENIC HWY 98	FAIRHOPE	AL	36532	\$1,383.20	5/14/2015
1012610-116055461	1001367	102040500	135 GREENBAY DR	DAPHNE	AL	36526	(\$32.31)	5/15/2015
1013696-117455606	1007948	110015961	224 S LAWRENCE ST	MOBILE	AL	36602	(\$9.08)	5/18/2015
1005964-108028453	1016142	117376007	11339 CAYE FALLS ST	FAIRHOPE	AL	36532	\$14.15	5/22/2015
1014767-117377051	1013573	117095484	200 AUTUMN DR #2B	FAIRHOPE	AL	36532	\$664.45	5/26/2015
1012533-116156480	1015973	117040876	7802 DIAMOND OAK DR	TEXAS CITY	TX	77598	\$23.78	5/26/2015
1017058-118104001	1004261	104006726	208 FAIRHOPE AVE APT 9	FAIRHOPE	AL	36532	\$99.56	5/27/2015
1011580-115259123	1009173	110095915	901 GAYFER AVE APT 1025	FAIRHOPE	AL	36532	\$95.35	5/27/2015
1014846-117857404	1017067	118103112	PO BOX 190081	MOBILE	AL	36619	\$81.64	5/27/2015
1023727-125901192	1001526	102042322	26 W GUNN ST	NOXAPATER	MS	39346	\$151.21	5/29/2015
1004258-104568005	1002805	103065261	16962 LEA CIRCLE	FAIRHOPE	AL	36532	\$79.88	5/29/2015
1001733-102045134	1003663	103065525	P O BOX 2500	ORANGE BEACH	AL	36561	\$172.12	6/2/2015
1011661-115256904	1013216	117040839	9556 COUNTY RD 34 #11	FAIRHOPE	AL	36532	\$398.23	6/3/2015
1017683-119000995	1001746	102042375	2708 AVENUE P 1/2	GALVESTON	TX	77550	\$27.80	6/4/2015
1020974-120068564	1018498	119003584	82 PLANTATION PT RD #192	FAIRHOPE	AL	36532	\$107.29	6/4/2015
1006330-109425602	1019013	119258928	11151 MOFFETT RD	WILMER	AL	36587	\$93.78	6/4/2015
1001836-102050125	1021375	121056701	PO BOX 391	POINT CLEAR	AL	36564	\$51.13	6/4/2015
1004654-104104143	1009163	110092766	901 GAYFER AVE #1014	FAIRHOPE	AL	36532	\$107.23	6/5/2015
1001196-102040420	1018477	119005785	18172 SECTION ST #2701	FAIRHOPE	AL	36532	\$99.81	6/8/2015
1004988-104106418	1024192	125863505	2725 JOHN HAWKINS PKWY	HOOVER	AL	35244	(\$0.64)	6/8/2015
1009024-110095816	1003352	103062253	14499 STATE HWY 181	FAIRHOPE	AL	36532	\$82.48	6/8/2015
1006368-109024085	1003472	103075423	13450 MARLOW CEMETARY RD	SUMMERDALE	AL	36580	\$46.37	6/8/2015
1009484-111025714	1009104	110125521	901 GAYFER AVE APT 625	FAIRHOPE	AL	36532	\$750.33	6/12/2015
1006524-109048520	1008099	110017831	8655 BROOK LN	FAIRHOPE	AL	36532	\$931.43	6/15/2015
1013941-117180071	1007231	110052703	612 FAIRHOPE AVE APT L	FAIRHOPE	AL	36532	\$158.66	6/15/2015
1005362-104106666	1005358	104106670	7320 1ST AVE	LOXLEY	AL	36551	\$60.97	6/15/2015
1006355-109020857	1002133	102035715	54 N CHURCH ST APT 12	FAIRHOPE	AL	36532	\$130.13	6/16/2015
1005558-106023153	1004338	104152610	13357 CATHEDRAL LN	SILVERHILL	AL	36576	\$122.82	6/18/2015
1010762-113048023	1008453	110026533	705 E 5TH ST	BAY MINETTE	AL	36507	\$204.07	6/23/2015
1005206-104107962	1013586	117130616	15551 COUNTY RD 49 #11	SUMMERDALE	AL	36580	\$628.21	6/24/2015
1018916-119568786	1009595	111041014	462 N SECTION ST	FAIRHOPE	AL	36532	\$46.16	6/29/2015
1007783-110017373	1009487	111025627	3487 RIVERBEND COVE	D'IBERVILLE	MS	39540	\$274.64	6/29/2015

City of Fairhope

Write off Customer Terminated balances as of 6/01/2021

Customer Info	Property ID	Customer ID	Address 1	City	State	Zip Code	Total Unpaid	Stop Date
1013786-117127461	1004780	104101678	16190 JUNIPER LN	SUMMERDALE	AL	36580	\$8.78	6/29/2015
1020791-120082541	1024297	125830042	231 MAPLEWOOD LOOP	DAPHNE	AL	36526	\$40.56	6/29/2015
1001398-102040515	1002129	102026533	54 N CHURCH ST #8	FAIRHOPE	AL	36532	\$117.73	6/30/2015
1013940-117180064	1013954	117455605	13455 OLD COUNTY RD 32	SUMMERDALE	AL	36580	\$364.64	6/30/2015
1005374-104125910	1009941	111076424	21950 LAKE FOR BLVD #209	DAPHNE	AL	36526	\$336.23	7/5/2015
1005829-108025466	1010844	114006906	364 S CHURCH ST	FAIRHOPE	AL	36532	\$60.35	7/6/2015
1006821-110023779	1006107	109016518	31 WINTERHAVEN CT	FAIRHOPE	AL	36532	\$368.63	7/6/2015
1005301-104116580	1022967	124003355	28846 WEYBRIDGE DR	WESTLAKE	OH	44145	\$0.20	7/6/2015
1000366-112021503	1013931	117146900	510 LAKE FOREST BLVD	DAPHNE	AL	36526	\$350.74	7/7/2015
1005759-107029237	1005558	106023153	107 S BAYVIEW ST	FAIRHOPE	AL	36532	\$114.79	7/9/2015
1005312-104125542	1009301	111006601	212 ROYAL OAK DR	CHESAPEAKE	VA	23322	(\$9.22)	7/13/2015
1013552-117079139	1009180	110056563	PO BOX 2213	FAIRHOPE	AL	36533	\$200.00	7/13/2015
1009920-111452604	1013233	117040884	8494 COUNTY RD 11	FAIRHOPE	AL	36532	\$82.09	7/14/2015
1017198-119026588	1012610	116055461	816 ARTILLERY RANGE W	SPANISH FT	AL	36527	\$17.25	7/14/2015
1017738-119001369	1013224	117452137	9556 COUNTY RD 34 #17	FAIRHOPE	AL	36532	\$179.58	7/15/2015
1018601-119002322	1004630	104104050	14231 COUNTY RD 32	SUMMERDALE	AL	36580	\$72.86	7/15/2015
1008453-110026533	1013236	117040894	9556 COUNTY RD 34 #6	FAIRHOPE	AL	36532	\$68.59	7/15/2015
1008038-110025421	1013662	117127404	601 BURNS ST #801	CAROL STREAM	IL	60188	\$341.33	7/17/2015
1006374-109023985	1008016	110002000	8555 BUCKINGHAM CT	SPANISH FT	AL	36527	\$55.18	7/20/2015
1017749-119856492	1018983	119199976	20323 COUNTY RD 49	SILVERHILL	AL	36576	\$119.47	7/24/2015
1003910-103067401	1005357	104100208	15871 RED STAR DR LOT 21	SUMMERDALE	AL	36580	\$313.04	7/24/2015
1011085-114018657	1010440	113003011	15 MAGNOLIA BLUFF DR	GAUTIER	MS	39553	\$582.99	7/27/2015
1007201-110047571	1009913	111037450	806 N GREENO RD LOT 3	FAIRHOPE	AL	36532	\$955.06	7/29/2015
1001225-102040474	1010685	113040634	10103 KENLEY WAY	BIRMINGHAM	AL	35242	\$0.27	7/29/2015
1005365-104100512	1004759	104125414	12040 MARGARET DR	SUMMERDALE	AL	36580	\$514.93	7/29/2015
1013753-117126580	1014961	117130553	4781 SUMMERHILL DR	CLARKSTON	MI	48346	\$0.03	7/30/2015
1008558-110025976	1006733	110018001	24872-AJEMISON RD	DAPHNE	AL	36526	\$665.48	7/30/2015
1005674-107048596	1001826	102050912	10647 US HWY 98	FAIRHOPE	AL	36532	\$87.74	7/31/2015
1014846-117857410	1008413	110023845	9505 MOSLEY RD	FAIRHOPE	AL	36532	\$15.67	7/31/2015
1004434-104100304	1005807	108003507	6641 WILLOWBRIDGE DR	FAIRHOPE	AL	36532	\$1,143.86	7/31/2015
1001514-102042293	1022819	124003408	103 LAKE COVE CIR	DAPHNE	AL	36526	\$59.38	7/31/2015
1015052-117130550	1008913	110067583	29919 SAINT SIMON ST	DAPHNE	AL	36526	\$769.93	8/3/2015
1013222-117040897	1016758	117042195	316 BLACKFRIARS ST	FAIRHOPE	AL	36532	\$31.54	8/3/2015
1024019-125256982	1004700	104105243	17811 FOX BRANCH DRIVE	LOXLEY	AL	36551	\$56.44	8/3/2015
1015449-117655234	1010505	113012488	3110 THOMAS AVE	MONTGOMERY	AL	36106	\$232.29	8/3/2015
1007729-110452876	1016676	117046931	10824 SANDY LN	FAIRHOPE	AL	36532	\$219.82	8/3/2015
1017067-118103112	1005973	108125477	259 EQUITY ST	FAIRHOPE	AL	36532	\$140.76	8/3/2015
1012263-116083500	1015953	117040555	30627 PINYON DR	SPANISH FORT	AL	36527	\$270.37	8/3/2015
1008004-110025646	1013463	117652156	3 PIRATES LANE	SPANISH FORT	AL	36527	\$572.42	8/4/2015
1018983-119199976	1005017	104106313	14329 BROOK HOLLOW RD	SUMMERDALE	AL	36580	\$91.95	8/4/2015
1013852-117103157	1013488	117066035	7935 GREENO LN	FAIRHOPE	AL	36532	\$356.98	8/4/2015
1015093-117130559	1012305	116241610	54916 CHAFIN RD	BAY MINETTE	AL	36507	\$432.57	8/5/2015
1007250-110023710	1011491	115324803	27320 MAIN ST	DAPHNE	AL	36526	\$326.23	8/5/2015
1002183-102025412	1003503	103065376	10720 COUNTY RD 32 LOT 12	FAIRHOPE	AL	36532	\$148.92	8/5/2015
1009207-110096700	1017072	118102499	100 RITA AVE	SPANISH FORT	AL	36527	\$105.59	8/5/2015
1008970-110023736	1001665	102050273	592 MARTINSVILLE LP	ATMORE	AL	36502	\$454.01	8/6/2015
1013462-117067400	1005088	104107684	14405 RIVERSIDE DR	FOLEY	AL	36535	\$192.25	8/7/2015
1013791-117185902	1023515	124002930	8355 MYSTIC GREENS WAY	NAPLES	FL	34113	\$0.04	8/7/2015
1013238-117045612	1017198	119026583	6843 TWIN BEECH RD LOT B	FAIRHOPE	AL	36532	\$200.90	8/11/2015
1009151-110095853	1005614	107125407	302 KATHRYN AVE	DECATUR	GA	30030	(\$5.67)	8/12/2015
1001225-102040490	1007551	110021367	PO BOX 6076	BILLOXI	MS	39540	\$4,026.31	8/12/2015
1014051-117250502	1009158	110092790	915 HWY 51 S	GRENADA	MS	38901	\$748.09	8/13/2015
1018615-119002038	1007814	110017376	8137 GAYFER EXT #1101	FAIRHOPE	AL	36532	\$1,086.03	8/13/2015
1021456-121081577	1013561	117086553	198 AUTUMN DR LOT 6	FAIRHOPE	AL	36532	\$1,365.75	8/14/2015
1013950-117186902	1001008	101109067	55 S CHURCH ST #D	FAIRHOPE	AL	36532	\$180.23	8/17/2015
1004359-104125778	1009348	111011455	411 GRAND AVE	FAIRHOPE	AL	36532	\$1,213.49	8/17/2015
1014948-117130033	1009029	110095891	17830 BALDWIN FARMS PL	ROBERTSDALE	AL	36567	\$182.37	8/18/2015
1004433-104155604	1000385	115137818	67 CARNWATH CT	EDISON	NJ	08817	(\$0.46)	8/18/2015
1009702-111037606	1013230	117040298	9556 COUNTY RD 34 LOT 1	FAIRHOPE	AL	36532	\$61.68	8/18/2015
1005774-107125471	1017683	119000973	19439 INGLESIDE	FAIRHOPE	AL	36532	\$25.07	8/20/2015
1013528-117086547	1005372	104100456	15888 BROOKWAY LOT 39	SUMMERDALE	AL	36580	\$61.28	8/20/2015
1015449-117655233	1005675	107049560	207 S MOBILE ST APT 212	FAIRHOPE	AL	36532	\$755.19	8/24/2015

City of Fairhope

Write off Customer Terminated balances as of 6/01/2021

Customer Info	Property ID	Customer ID	Address 1	City	State	Zip Code	Total Unpaid	Stop Date
1004444-104110533	1021207	121030908	6641 WILLOWBRIDGE DR	FAIRHOPE	AL	36532	\$414.77	8/25/2015
1004813-104101680	1013942	117189059	11 BURLINGTON DR	FAIRHOPE	AL	36532	\$103.32	8/28/2015
1017190-119000526	1009035	110045915	901 GAYFER AVE APT 227	FAIRHOPE	AL	36532	\$650.83	8/31/2015
1000627-124001617	1015749	117611173	215 BELL COURT	CHICKASAW	AL	36611	\$26.74	8/31/2015
1014916-117625451	1013222	117040905	9556 COUNTY RD 34 LOT 15	FAIRHOPE	AL	36532	\$75.11	9/1/2015
1008652-110030105	1005776	107014720	117 FELS AVE	FAIRHOPE	AL	36532	\$1,409.90	9/1/2015
1018078-119548703	1015176	117620114	11564 LISA COURT	FAIRHOPE	AL	36532	\$26.45	9/1/2015
1013929-117104503	1001873	102050184	13649 GRIFFIN LN	FAIRHOPE	AL	36532	\$150.63	9/2/2015
1000484-119000259	1003496	103015961	P O BOX 1002	POINT CLEAR	AL	36564	\$142.25	9/2/2015
1016238-117625407	1006554	109055427	16927 STATE HWY 181	FAIRHOPE	AL	36532	\$112.56	9/3/2015
1013552-117126471	1001775	102050996	10090 HWY 98	FAIRHOPE	AL	36532	\$1,093.76	9/3/2015
1024051-125000613	1005587	106021126	PO BOX 2082	FAIRHOPE	AL	36533	\$53.66	9/4/2015
1010505-113012488	1001836	102050125	10936 HWY 98	FAIRHOPE	AL	36532	\$434.09	9/4/2015
1016208-117611023	1011398	115137840	6995 PINEHILL RD	DAPHNE	AL	36526	\$55.11	9/4/2015
1013770-117126555	1015542	117610947	10255 DUNSFORD DR	LONE TREE	CO	80124	\$83.30	9/8/2015
1017102-119236594	1015038	117137453	500 WESTCHASE CT N	FAIRHOPE	AL	36532	\$1,033.60	9/8/2015
1013533-117085480	1011503	115118247	25405 LAKESIDE TERRACE	LOXLEY	AL	36551	\$7.16	9/8/2015
1013553-117079112	1006873	110028467	7 N GRAND BLVD	FAIRHOPE	AL	36532	\$312.89	9/9/2015
1009314-111026589	1013541	117080160	198 AUTUMN DR #54	FAIRHOPE	AL	36532	\$2,195.29	9/9/2015
1013547-117079137	1013552	117079139	198 AUTUMN DR LOT 12	FAIRHOPE	AL	36532	\$1,313.26	9/9/2015
1006391-109046580	1011064	114028470	24466 GEMSTONE DR	LOXLEY	AL	36551	\$336.00	9/9/2015
1005848-108012607	1003413	103062517	12000 LAVENDER LANE	FAIRHOPE	AL	36532	(\$7.20)	9/10/2015
1007232-110047974	1011216	114014125	514 DYSON ST	FAIRHOPE	AL	36532	\$720.84	9/11/2015
1006107-109016518	1015728	117611179	12575 CLAY CITY RD UNIT B	FAIRHOPE	AL	36532	\$201.21	9/11/2015
1023565-124088506	1020974	120068566	8111 MCGOWIN DR	FAIRHOPE	AL	36532	\$478.70	9/11/2015
1009922-111258606	1016119	117375172	22969 RIVER RD S	DAPHNE	AL	36526	\$48.23	9/14/2015
1011643-115291451	1001687	102050278	13846 KELLER RD	FAIRHOPE	AL	36532	\$14.04	9/15/2015
1013228-117045939	1009121	110095916	576 MORRISON FARM RD	TROUTMAN	NC	28166	\$623.46	9/15/2015
1009136-110092502	1013562	117086554	2621 S JUNIPER	FOLEY	AL	36535	\$140.68	9/17/2015
1013234-117045702	1008413	110023949	9505 MOSLEY RD	FAIRHOPE	AL	36532	\$8.78	9/18/2015
1013515-117080181	1016719	117042185	1503 MCMILLAN AVE	BREWTON	AL	36426	\$119.66	9/18/2015
1015055-117136523	1001761	102012541	9650 US HWY 98 LOT 9	FAIRHOPE	AL	36532	\$136.66	9/21/2015
1017824-119258941	1013292	117452136	8160 COUNTY RD 64 #911	DAPHNE	AL	36526	\$175.56	9/21/2015
1008362-110023967	1003756	103456981	12144 MEADOW RD LOT 8	FAIRHOPE	AL	36532	\$587.64	9/21/2015
1017700-119003848	1005513	105023625	552 MORPHY AVE	FAIRHOPE	AL	36532	(\$1.22)	9/22/2015
1013093-116195680	1016455	117782357	PO BOX 680933	PRATTVILLE	AL	36068	\$114.13	9/29/2015
1006772-110025786	1004339	104152808	25391 PATTERSON RD	ROBERTSDALE	AL	36567	\$2.69	9/30/2015
1006358-109024090	1015710	117612511	10880 GAYFER RD EXT APT E	FAIRHOPE	AL	36532	\$28.07	9/30/2015
1006744-110125464	1019132	119257172	1132 GOLF VIEW WOODS	RUSKIN	FL	33573	\$141.25	10/1/2015
1017683-119000973	1003770	103063297	12144 MEADOW RD LOT 19	FAIRHOPE	AL	36532	\$350.33	10/2/2015
1008320-110014350	1018654	119002352	5221 BURMA ROAD W	MOBILE	AL	36693	\$199.23	10/6/2015
1010782-113049858	1013462	117067400	2206 COX RD	RICHMOND	VA	23294	\$25.99	10/7/2015
1013231-117045924	1015696	117611132	104 CRESTVIEW CIR	DAPHNE	AL	36526	\$295.55	10/8/2015
1002137-102030871	1015488	117611001	21310 STATE HWY 181 #26	FAIRHOPE	AL	36532	\$181.95	10/8/2015
1015454-117611166	1017681	119571423	PO BOX 1675	FAIRHOPE	AL	36533	\$38.26	10/12/2015
1013548-117079111	1017694	119001341	227 BIG OAK LN	BRENT	AL	35034	\$32.98	10/13/2015
1018555-119002174	1017700	119003710	18957 BRACY LANE	FAIRHOPE	AL	36532	\$987.40	10/13/2015
1006623-109085471	1017183	119123609	6655 TWIN BEECH RD	FAIRHOPE	AL	36532	\$263.67	10/13/2015
1016355-117782340	1017734	119236516	626 MIDDLE ST	FAIRHOPE	AL	36532	\$189.19	10/13/2015
1016354-117782341	1003721	103070558	11950 COUNTY RD 32 LOT 10	FAIRHOPE	AL	36532	\$100.75	10/14/2015
1019150-119005325	1012948	116600494	31185 BLAKELEY WAY	SPANISH FORT	AL	36527	\$118.59	10/14/2015
1008553-110025624	1021041	121004656	PO BOX 1141	FAIRHOPE	AL	36533	\$353.41	10/14/2015
1012537-116123002	1012903	116184445	9200 CEDAR CT	SPANISH FORT	AL	36527	\$28.12	10/14/2015
1015444-117611269	1012460	116132541	30 CAISSON TRACE	SPANISH FORT	AL	36527	\$123.63	10/14/2015
1013560-117079218	1013705	117125623	201 SPRING RUN DR APT 50	FAIRHOPE	AL	36532	\$512.56	10/15/2015
1002548-103054874	1015698	117621544	10672-A GAYFER RD EXT	FAIRHOPE	AL	36532	\$186.08	10/15/2015
1010467-113026591	1011792	115312179	140 SILVERWOOD ST	MOBILE	AL	36607	\$491.67	10/15/2015
1018458-119566981	1009410	111013345	244 MORRIS ST	BESSEMER	AL	35022	\$90.92	10/16/2015
1005359-104125485	1013781	117126469	199 SPRING RUN APT 146	FAIRHOPE	AL	36532	\$200.15	10/16/2015
1013551-117079106	1005341	104152696	15840 RED STAR DR LOT 12	SUMMERDALE	AL	36580	\$33.33	10/16/2015
1002814-103060065	1009148	110092732	901 GAYFER AVE APT 822	FAIRHOPE	AL	36532	\$596.46	10/16/2015
1002329-103065460	1009257	111056999	3725 S IMPORT WAY	AURORA	CO	80014	\$944.15	10/19/2015

City of Fairhope

Write off Customer Terminated balances as of 6/01/2021

Customer Info	Property ID	Customer ID	Address 1	City	State	Zip Code	Total Unpaid	Stop Date
1021254-121085478	1009152	110009535	1720 PLEASANT RD	DAPHNE	AL	36526	\$648.18	10/26/2015
1011491-115324803	1014660	117350601	13881 DOUGLAS WAY	FOLEY	AL	36535	\$14.04	10/28/2015
1009148-110092732	1009295	111006228	10252 MISSION TRACE #13	FAIRHOPE	AL	36532	\$6.15	11/2/2015
1011600-115021543	1004094	103024628	312 FAIRHOPE AVE	FAIRHOPE	AL	36532	\$322.27	11/2/2015
1004555-104105201	1001330	102040357	82 PLANTATION POINTE	FAIRHOPE	AL	36532	\$150.15	11/2/2015
1005358-104106684	1008147	110782158	9129 GAYFER RD EXT	FAIRHOPE	AL	36532	\$2,302.91	11/3/2015
1017875-119003446	1001759	102046513	9650 US HWY 98 #11	FAIRHOPE	AL	36532	\$87.03	11/3/2015
1011600-115021545	1009614	111048510	8894 LAKE VIEW DR	FAIRHOPE	AL	36532	\$233.48	11/3/2015
1000398-115295870	1007057	110018105	14251 STATE HWY 104 #34	SILVERHILL	AL	36576	\$1,295.31	11/4/2015
1007586-110025750	1006984	110019238	722 GAYFER AVE	FAIRHOPE	AL	36532	\$1,436.93	11/4/2015
1017205-119856002	1008571	110235145	207 LEE STREET	FAIRHOPE	AL	36532	\$418.89	11/4/2015
1021053-119856002	1016056	117856324	18710 HIGHLAND DR	FAIRHOPE	AL	36532	(\$1.35)	11/4/2015
1005472-105012518	1022320	124021552	7190 ECOR DECHENE CT	FAIRHOPE	AL	36533	\$241.24	11/4/2015
1006149-109016737	1009915	111075846	806 N GREENO LOT 4	FAIRHOPE	AL	36532	\$97.50	11/5/2015
1007798-110017878	1001354	102040499	1616 WORTHY RD	ALEX CITY	AL	35010	\$119.93	11/5/2015
1014660-117350601	1011214	114025633	514 DYSON ST	FAIRHOPE	AL	36532	\$799.20	11/6/2015
1005216-104110021	1007966	110015900	9 HOFFREN DR	FAIRHOPE	AL	36532	\$35.47	11/6/2015
1021747-122050276	1016355	117782340	324 LEE RD 849	OPELIKA	AL	36804	\$0.39	11/6/2015
1004592-104103627	1016354	117782341	324 LEE RD 849	OPELIKA	AL	36804	\$129.72	11/6/2015
1000441-117080120	1003702	103063992	14895 COUNTY RD 48	FAIRHOPE	AL	36532	\$405.38	11/6/2015
1010927-107002407	1013533	117085476	198 AUTUMN DR LOT 26	FAIRHOPE	AL	36532	\$1,278.80	11/6/2015
1012026-115343114	1008539	110093056	21081 BISHOP RD #2	FAIRHOPE	AL	36532	\$139.17	11/9/2015
1007821-110017983	1000877	101059570	1126 FAY ROAD	KEMAH	TX	77535	\$213.02	11/9/2015
1003470-103061488	1018877	119005475	215 KEYBURG RD	GLENNCO	AL	35905	(\$7.96)	11/9/2015
1011633-115285615	1005718	107452894	210 S MOBILE ST APT 7	FAIRHOPE	AL	36532	\$308.92	11/12/2015
1006036-109014402	1006537	109057007	105 1/2 MERSHON ST	FAIRHOPE	AL	36532	\$356.45	11/17/2015
1015963-117040685	1015437	117611002	10203 MISSION TRACE LOT 9	FAIRHOPE	AL	36532	\$31.73	11/17/2015
1011007-114013489	1008624	110015300	3 PORCH PLACE WAY	FAIRHOPE	AL	36532	\$886.45	11/17/2015
1006983-110023799	1009125	110093057	9600 COUNTY RD 34	FAIRHOPE	AL	36532	\$158.89	11/19/2015
1019365-119005792	1015568	117610973	2063 HIGHWAY 13	PHIL CAMPBELL	AL	35581	\$133.30	11/20/2015
1004066-103018080	1006821	110023779	11738 BALSAM COURT	SPANISH FORT	AL	36527	\$53.37	11/20/2015
1023155-124002297	1001733	102045135	9650 US HWY 98 LOT 20	FAIRHOPE	AL	36532	\$229.97	11/23/2015
1023154-124002298	1013222	117040918	19000 OAK ROAD W #02101	GULF SHORES	AL	36542	\$27.14	11/24/2015
1013617-117080150	1021974	123256901	829 2ND AVE	PLEASANT GRV	AL	35127	\$95.20	11/24/2015
1015018-117125633	1023731	125956482	9559 CANTERBURY CT	DAPHNE	AL	36526	\$33.69	11/25/2015
1004338-104152610	1004491	104125633	18790 COUNTY RD 9	SILVERHILL	AL	36576	\$64.59	12/1/2015
1004780-104101678	1015695	117855477	108 APPAMATOX DR	DAPHNE	AL	36526	\$1,319.83	12/1/2015
1021975-123156900	1017847	119254738	16427 COUNTY RD 3	FAIRHOPE	AL	36532	\$100.96	12/1/2015
1017338-119257164	1005346	104100251	15796 RED STAR DR LOT 45	SUMMERDALE	AL	36580	\$125.26	12/1/2015
1001329-102040274	1005596	106125607	251 SINBURY DR N	WORTHINGTON	OH	43805	\$757.66	12/2/2015
1022819-124003408	1008573	110026604	27642 HIGHWAY 98 APT 537	DAPHNE	AL	36526	\$221.61	12/2/2015
1013551-117079061	1016423	117782249	9526 CHARIOT AVE	FAIRHOPE	AL	36532	\$274.67	12/2/2015
1008991-110090451	1013225	117610987	9556 COUNTY RD 34 LOT 18	FAIRHOPE	AL	36532	\$140.51	12/2/2015
1008251-110025440	1005329	104154803	7292A ROSCOE RD	GULF SHORES	AL	36542	\$105.39	12/3/2015
1009754-111035466	1015308	117256997	PO BOX 803	BRINKLEY	AR	72021	(\$0.57)	12/3/2015
1012659-116182503	1001228	102040980	11339 COUNTY RD 1	FAIRHOPE	AL	36532	\$30.35	12/3/2015
1024300-125830045	1010110	111017586	10407 US HWY 31 #395	SPANISH FORT	AL	36527	\$791.31	12/4/2015
1005583-106023668	1010661	113031718	8760 COUNTY RD 64	DAPHNE	AL	36526	\$33.12	12/5/2015
1009183-110092785	1009690	111026610	PO BOX 1287	FAIRHOPE	AL	36533	(\$0.47)	12/7/2015
1002329-103066530	1015475	117622505	21400 ST HWY 181 LOT 12	FAIRHOPE	AL	36532	\$273.96	12/7/2015
1004266-104126596	1009484	111025714	24138 GEMSTONE DR	LOXLEY	AL	36551	\$1,114.16	12/7/2015
1021044-121045877	1018870	119003183	19626 THOMPSON HALL RD #8	FAIRHOPE	AL	36532	\$163.43	12/8/2015
1007642-110025779	1018863	119254141	2126 S 7TH ST	OCEAN SPRINGS	MS	39564	\$184.07	12/8/2015
1015015-117236580	1018093	119125600	9104 MORPHY AVE LOT 10	FAIRHOPE	AL	36532	\$241.76	12/8/2015
1008409-110025854	1017665	119213603	7470 TWIN BEECH RD #A	FAIRHOPE	AL	36532	\$258.03	12/8/2015
1014969-117130374	1017107	119003829	18653 TWIN BEECH RD	FAIRHOPE	AL	36532	\$246.86	12/8/2015
1015500-117611214	1018694	119257061	985 WHITTIER ST	FAIRHOPE	AL	36532	\$185.44	12/8/2015
1009092-110091720	1017415	119000787	PO BOX 364	POINT CLEAR	AL	36564	\$46.88	12/8/2015
1018446-119256405	1017595	119001709	7915 TWIN BEECH RD	FAIRHOPE	AL	36532	\$276.33	12/8/2015
1014962-117135245	1018677	119003791	PO BOX 1951	FAIRHOPE	AL	36533	\$606.52	12/9/2015
1003770-103063297	1013510	117080717	26538 LOXLEY HEIGHTS RD	LOXLEY	AL	36551	\$302.01	12/10/2015
1005122-104125611	1018545	119257039	121 D'ESTRAHAN	FAIRHOPE	AL	36532	\$517.45	12/11/2015

City of Fairhope

Write off Customer Terminated balances as of 6/01/2021

Customer Info	Property ID	Customer ID	Address 1	City	State	Zip Code	Total Unpaid	Stop Date
1009920-111452600	1016758	117042202	316 BLACKFRIARS ST	FAIRHOPE	AL	36532	\$110.87	12/11/2015
1000289-110019078	1002814	103060065	251 N QUAIL TRAIL	CLARKSVILLE	GA	30523	\$14.22	12/11/2015
1008581-110095836	1006703	117135406	56 BERGLIN ST	FAIRHOPE	AL	36532	\$674.26	12/14/2015
1007949-110025653	1004171	104002150	205 FAIRHOPE AVE #C	FAIRHOPE	AL	36532	\$243.84	12/14/2015
1001686-102050952	1009918	111069868	806 N GREENO RD LOT 7	FAIRHOPE	AL	36532	\$404.92	12/14/2015
1023769-125901045	1015477	117626517	21400 STATE HWY 181 LOT 8	FAIRHOPE	AL	36532	\$125.34	12/15/2015
1002858-103060795	1004699	104104514	640 RIDGEWOOD DR	FAIRHOPPE	AL	36532	\$121.18	12/16/2015
1001554-102055702	1006740	110025861	805 HORN LANE	FAIRHOPE	AL	36532	\$756.51	12/17/2015
1014789-117425161	1006149	109016737	PO BOX 608	FAIRHOPE	AL	36533	\$731.41	12/17/2015
1009171-110097502	1013523	117085488	198 AUTUMN DR LOT 48	FAIRHOPE	AL	36532	\$763.14	12/18/2015
1014840-117402389	1015442	117610475	10252 MISSION TRACE	FAIRHOPE	AL	36532	\$28.49	12/18/2015
1007130-110025660	1019141	119005941	10315 LONGLEAF LN	FAIRHOPE	AL	36532	\$585.93	12/21/2015
1009131-110024592	1005990	109002036	10966 HILTON LN	FAIRHOPE	AL	36532	\$204.24	12/21/2015
1006084-109016571	1010615	113038457	4950 TUFTS RD	MOBILE	AL	36619	\$303.48	12/21/2015
1001756-102047500	1009092	110091720	901 GAYFER AVE #514	FAIRHOPE	AL	36532	\$102.01	12/30/2015
1017750-119002478	1006309	109023690	7341 KIRKMAN LANE	FAIRHOPE	AL	36532	\$515.41	1/4/2016
1011503-115118247	1009913	111037452	701 SOUTH JUNIPER ST #59	FOLEY	AL	36535	\$490.28	1/4/2016
1017178-119254792	1017747	119855601	19265 B YOUNG ST	FAIRHOPE	AL	36532	\$33.04	1/5/2016
1005581-106023680	1017738	119001369	19108 DENTON LANE	FAIRHOPE	AL	36533	\$245.41	1/6/2016
1000858-101052363	1007798	110017878	333 KNOLLWOOD AVE	FAIRHOPE	AL	36532	\$259.80	1/6/2016
1009151-110095846	1006248	109026639	7695 LLOYD LANE	FAIRHOPE	AL	36532	\$237.43	1/7/2016
1023761-125900000	1015315	117856473	9820 MILTON JONES RD	DAPHNE	AL	36526	\$77.45	1/8/2016
1005513-105023625	1013844	117103298	440 SADIE DR	MATTHEWS	NC	28105	\$45.36	1/8/2016
1005042-104106628	1008562	110096571	5279 E PERDIDO	ORANGE BCH	AL	36561	\$33.97	1/11/2016
1005794-107251301	1001086	101077405	311 S SECTION ST	FAIRHOPE	AL	36532	\$66.75	1/11/2016
1015749-117611173	1006300	109045215	113 FERNWOOD CIRCLE	DAPHNE	AL	36526	\$200.32	1/11/2016
1008540-110012549	1009136	110092502	901 GAYFER AVE APT 815	FAIRHOPE	AL	36532	\$694.82	1/12/2016
1021974-123251200	1004759	104125424	12040 MARGARET DR	SUMMERDALE	AL	36580	\$1,980.60	1/13/2016
1018476-119567483	1005829	108025466	256 LIBERTY ST	FAIRHOPE	AL	36532	\$708.68	1/13/2016
1015280-117856936	1001741	102042352	9650 US HWY 98 LOT 26	FAIRHOPE	AL	36532	\$100.85	1/13/2016
1000062-102050289	1004555	104105201	13320 ETTA SMITH RD	SUMMERDALE	AL	36580	\$379.15	1/14/2016
1006832-110025551	1005122	104125611	3892 GOLDEN ACRES CIR	CRESTVIEW	FL	32539	\$57.81	1/14/2016
1015696-117611101	1004635	104021305	14300 COUNTY RD 32	SUMMERDALE	AL	36580	\$282.25	1/14/2016
1006208-109022301	1013541	117080163	6383 HENSHAW RD	FAIRHOPE	AL	36532	\$77.25	1/19/2016
1009915-111075846	1009282	111028514	417 FAIRWOOD BLVD	FAIRHOPE	AL	36532	\$953.03	1/19/2016
1014834-117610927	1004684	104104407	13494 PENDIX RD B	SUMMERDALE	AL	36580	\$136.12	1/20/2016
1008667-110023603	1005359	104125519	PO BOX 802	SILVERHILL	AL	36576	\$92.25	1/20/2016
1013912-117025805	1004498	104125761	18562 COUNTY RD 9 LOT B	SILVERHILL	AL	36576	\$54.93	1/21/2016
1009202-110095803	1005586	106023673	107 S MOBILE ST C-2	FAIRHOPE	AL	36532	\$803.74	1/22/2016
1024191-125830043	1020590	120047948	2001 KIRBY DR STE-811	HOUSTON	TX	77019	\$22.51	1/22/2016
1001479-102042203	1004444	104110533	13699 MEADOW RIDGE LN	SILVERHILL	AL	36576	\$274.67	1/24/2016
1019187-119004334	1013282	117040261	1414 BERKSHIRE DR	BRANDON	FL	33511	\$248.01	1/25/2016
1022050-123135501	1006748	110004028	PO BOX 1362	FAIRHOPE	AL	36533	\$1,430.48	1/26/2016
1000877-101059570	1000281	110004040	PO BOX 1362	FAIRHOPE	AL	36533	\$608.75	1/26/2016
1009145-110092795	1009145	110092798	10860 DANNE LN	ELBERTA	AL	36530	\$2,104.20	1/26/2016
1015480-117610748	1011578	115265875	30990 STANTON RD	SPANISH FORT	AL	36527	\$165.49	1/27/2016
1009095-110096354	1017551	119001002	19840 BUDS LANE	FAIRHOPE	AL	36532	\$31.92	1/29/2016
1012016-115362003	1013222	117040927	322 COUNTY RD 528	SELMA	AL	36703	\$9.15	1/29/2016
1009922-111258600	1011433	115147008	27243 PARKER LN	DAPHNE	AL	36526	\$1,736.83	1/29/2016
1006203-109452600	1019843	119568006	250 CARSON OAKS LN	SANTA ROSA	FL	32459	\$213.92	2/1/2016
1015710-117612511	1004681	104101208	14340 COUNTY RD 9	FOLEY	AL	36535	\$36.73	2/1/2016
1001759-102046513	1005366	104125904	21950 8TH ST	SILVERHILL	AL	36576	\$56.98	2/1/2016
1005066-104106848	1002129	102026534	12475 B MARY ANN BEACH RD	FAIRHOPE	AL	36532	\$390.28	2/1/2016
1013553-117085604	1017007	118089750	5756 CLARK CIR W	SATSUMA	AL	36572	\$171.22	2/2/2016
1011784-115312598	1001234	102040371	100 NELSON FARM RD	Lk PROVIDENCE	LA	71254	(\$1.50)	2/2/2016
1002012-102050954	1020791	120082541	19502 LIBERTY RD	FAIRHOPE	AL	36532	\$126.40	2/2/2016
1013516-117126617	1005499	105952802	565 STIMPSON AVE	FAIRHOPE	AL	36532	\$790.56	2/2/2016
1017681-119571423	1024295	125830050	25067 JERNIGAN ST	DAPHNE	AL	36526	\$248.82	2/2/2016
1013235-117040930	1018628	119001870	129 CLUB DR	FAIRHOPE	AL	36532	\$1,866.30	2/2/2016
1009090-110236581	1005312	104125542	24319 HAYNES CT	ROBERTSDALE	AL	36567	\$150.07	2/4/2016
1012504-116159002	1014840	117402353	19027 COUNTY RD 33 #6	FAIRHOPE	AL	36532	\$52.43	2/4/2016
1017847-119254738	1009529	111012550	103 FAIRHOPE CT #9	FAIRHOPE	AL	36532	\$1,069.45	2/5/2016

City of Fairhope

Write off Customer Terminated balances as of 6/01/2021

Customer Info	Property ID	Customer ID	Address 1	City	State	Zip Code	Total Unpaid	Stop Date
1003524-103065130	1019584	119005601	104 HOMESTEAD APT 11	FAIRHOPE	AL	36532	\$81.33	2/5/2016
1010868-114006507	1006374	109023985	755 NORTHPROP AVE	FAIRHOPE	AL	36532	\$92.22	2/8/2016
1024059-125000630	1016661	117042006	PO BOX 491	DAPHNE	AL	36526	\$595.81	2/9/2016
1003702-103063992	1013236	117040917	9556 COUNTY RD 34 #6	FAIRHOPE	AL	36532	\$161.12	2/10/2016
1009256-111006913	1018530	119574816	500 ISLAND COURT	IRVING	TX	75061	\$36.35	2/10/2016
1003195-103060364	1006537	109057008	210 SILVERSMITH ST	FAIRHOPE	AL	36532	\$69.61	2/11/2016
1004092-103024628	1004262	104256916	208 FAIRHOPE AVE APT 19	FAIRHOPE	AL	36532	\$405.54	2/11/2016
1004094-103024628	1009104	110125525	26174 COUNTY RD 20	ELBERTA	AL	36530	\$348.32	2/15/2016
1013234-117045706	1022111	124125721	7625 PARKER RD LOT 68	FAIRHOPE	AL	36532	\$377.83	2/15/2016
1015974-117045929	1008108	110095883	21159 MEADOWBROOK DR	FAIRHOPE	AL	36532	\$652.55	2/15/2016
1013783-117059865	1007514	110016184	507 NICHOLS AVE	FAIRHOPE	AL	36532	\$1,079.45	2/16/2016
1004630-104104050	1004020	103009515	420 FAIRHOPE AVE	FAIRHOPE	AL	36532	\$1,320.77	2/16/2016
1004921-104106532	1001756	102047501	9650 HWY 98 LOT 13	FAIRHOPE	AL	36532	\$459.59	2/17/2016
1018064-119123652	1015928	117040467	162 VIVIAN LOOP	FAIRHOPE	AL	36532	\$323.66	2/19/2016
1014496-117325416	1009366	111237455	134 ANDERSON RD	TROY	AL	36079	\$464.41	2/19/2016
1010611-113030827	1005364	104100495	15979 RED STAR LOT 30	SUMMERDALE	AL	36580	\$128.12	2/19/2016
1000463-117130135	1023838	125890041	10777 GRANT'S RD	FAIRHOPE	AL	36532	\$84.28	2/23/2016
1013463-117652155	1013682	117126593	701 IROQUOIS ST	CHICKASAW	AL	36611	\$80.14	2/23/2016
1013463-117652157	1021042	121004659	PO BOX 191	POINT CLEAR	AL	36564	\$176.75	2/23/2016
1020952-120090631	1009282	111028515	417 FAIRWOOD BLVD	FAIRHOPE	AL	36532	\$83.33	2/23/2016
1015847-21095	1002094	102050901	10715 COUNTY RD 24 LOT 3	FAIRHOPE	AL	36532	\$83.04	2/23/2016
1013705-117125601	1013536	117854610	198 AUTUMN DR LOT 22	FAIRHOPE	AL	36532	\$287.94	2/23/2016
1012203-116002001	1014496	117325416	20210 RIVER MILL DR	FAIRHOPE	AL	36532	\$161.22	2/25/2016
1023579-124089744	1011099	114020915	20 TEEKS CROSSING WAY	SENOIA	GA	30276	\$517.52	2/26/2016
1009152-110009536	1017599	119213650	13029 LYMON LN	FOLEY	AL	36535	\$13.75	2/29/2016
1005357-104100278	1010838	114025709	6152 HOWELLS FERRY RD	MOBILE	AL	36618	\$270.62	2/29/2016
1016222-117611231	1007317	110048160	119 ASHLEY DR	FAIRHOPE	AL	36532	\$367.67	3/1/2016
1001864-102050209	1005838	108025691	306 LIBERTY STREET	FAIRHOPE	AL	36532	\$285.88	3/1/2016
1018526-119001788	1007201	110047571	PO BOX 65	DOLPH	AR	72528	\$201.21	3/1/2016
1004154-104165202	1014365	117326608	PO BOX 735	FAIRHOPE	AL	36533	\$165.08	3/3/2016
1013368-117059100	1009200	110025455	2545 EAST JOSHUA LN	FLAGSTAFF	AZ	86001	\$264.57	3/3/2016
1015437-117611002	1008538	110025541	21081 BISHOP RD #4	FAIRHOPE	AL	36532	\$219.07	3/4/2016
1013682-117126637	1015472	117610453	21400 STATE HWY 181 # 7	FAIRHOPE	AL	36532	\$9.15	3/4/2016
1013518-117080111	1012509	116182548	603 SPANISH MAIN	SPANISH FORT	AL	36527	\$62.52	3/7/2016
1014286-117782309	1009920	111452605	1379 RADGEWOOD	MOBILE	AL	36608	\$156.58	3/8/2016
1009023-110091315	1015006	117095219	P.O. BOX 1528	FAIRHOPE	AL	36533	\$88.52	3/8/2016
1003769-103061292	1004434	104100304	P O BOX 413	DAPHNE	AL	36526	\$83.92	3/8/2016
1011391-115137851	1008548	110096595	24294 HARVESTR DR	LOXLEY	AL	36551	\$448.19	3/8/2016
1013235-117040867	1009100	110093056	27642 US HWY 98 #332	DAPHNE	AL	36526	\$155.43	3/8/2016
1013375-117059965	1003470	103061493	1101 CAROLINE AVE	DAPHNE	AL	36526	\$80.79	3/9/2016
1003720-103065463	1013655	117854789	201 SPRINGRUN DR APT 23	FAIRHOPE	AL	36532	\$233.04	3/10/2016
1015469-117610691	1009207	110096700	901 GAYFER AVE #1312	FAIRHOPE	AL	36532	\$1,133.64	3/11/2016
1013222-117040918	1017804	119259630	6870 FOLEY BCH EXP #1424	ORANGE BCH	AL	36561	\$42.28	3/14/2016
1017842-119257023	1009013	110096780	901 GAYFER AVE APT 123	FAIRHOPE	AL	36532	\$910.16	3/14/2016
1005366-104125908	1017761	119256810	7684 TWIN BEECH RD #1201	FAIRHOPE	AL	36532	\$81.76	3/16/2016
1006193-109021606	1018916	119568789	17533 EASTVIEW LP	FOLEY	AL	36535	\$312.16	3/17/2016
1008190-110014085	1003726	103060664	16965 RIVER PARK RD	FAIRHOPE	AL	36532	\$331.89	3/17/2016
1015019-117130517	1017674	119001030	7341 TWIN BEECH RD	FAIRHOPE	AL	36532	\$167.53	3/18/2016
1018637-119004340	1018942	119003432	9655 DERBY LANE	FAIRHOPE	AL	36532	\$86.21	3/25/2016
1009926-111452135	1013317	117058594	19270 S GREENO RD LOT 59	FAIRHOPE	AL	36532	\$24.80	3/28/2016
1004635-104021303	1012489	116175484	508 GENERAL MAURY DR	SPANISH FT	AL	36527	\$289.68	3/28/2016
1008070-110025862	1009941	111076426	656 VOLANTA AVE	FAIRHOPE	AL	36532	\$1,015.86	3/28/2016
1000920-101031123	1013941	117180071	11 FRIDAY LANE	NEEDHAM	AL	36915	\$673.35	3/28/2016
1006848-110125474	1018085	119564230	102 BAYVIEW DR	DAPHNE	AL	36526	\$36.11	3/30/2016
1003496-103015961	1014836	117402388	19027 COUNTY RD 33 LOT 14	FAIRHOPE	AL	36532	\$108.66	3/30/2016
1013705-117125623	1006145	109016789	4690 BLFRETH JOHNSON RD	BIRMINGHAM	AL	35215	\$8.85	3/31/2016
1016176-117611120	1006853	110023877	1003 KINGSBURY AVE	BIRMINGHAM	AL	35213	\$280.64	3/31/2016
1004674-104104365	1002769	103652825	17405 ABINGDON LN	FAIRHOPE	AL	36532	\$9.99	3/31/2016
1004759-104125414	1004497	104125768	13265 JIMA LANE A	SILVERHILL	AL	36576	\$53.94	4/1/2016
1009907-111065007	1012001	115312589	2109 PARKWAY PLACE	INGLESIDE	TX	78362	\$101.79	4/1/2016
1013775-117125625	1009123	110125524	23437 COUNTY RD 38	SUMMERDALE	AL	36580	\$262.33	4/1/2016
1003503-103065376	1001746	102042380	P O BOX 671	FAIRHOPE	AL	36564	\$33.27	4/1/2016

City of Fairhope

Write off Customer Terminated balances as of 6/01/2021

Customer Info	Property ID	Customer ID	Address 1	City	State	Zip Code	Total Unpaid	Stop Date
1013560-117079219	1007102	110036529	715 FAIRHOPE AVE	FAIRHOPE	AL	36532	\$830.96	4/4/2016
1019282-119004811	1001056	101088008	202 GASTON AVE	FAIRHOPE	AL	36532	\$821.34	4/4/2016
1009918-111069872	1017749	119856495	19265 YOUNG ST	FAIRHOPE	AL	36532	\$62.01	4/4/2016
1010661-113031718	1007250	110023859	19290 SCENIC HWY 98	FAIRHOPE	AL	36532	\$378.38	4/4/2016
1010963-114025417	1018458	119566981	PO BOX 182	FAIRHOPE	AL	36533	\$162.74	4/5/2016
1013721-117126625	1006716	110003650	657 MORPHY AVE	FAIRHOPE	AL	36532	\$1,177.75	4/5/2016
1015218-117620106	1006524	109048523	508 PINE STREET	DAPHNE	AL	36526	\$96.87	4/5/2016
1000385-115137818	1014193	117265720	109 CONTI COURT	FAIRHOPE	AL	36532	(\$68.83)	4/6/2016
1013562-117086554	1009121	110095928	1412 US HWY 98	DAPHNE	AL	36526	\$214.39	4/8/2016
1013562-117086556	1014418	117305374	560 PINE HILL RD	JEMISON	AL	35085	\$55.52	4/8/2016
1013954-117455605	1011562	115252532	30483 SPANISH LANE	SPANISH FORT	AL	36527	\$28.50	4/11/2016
1023737-125901255	1009112	110099561	782 SERPENTINE DRIVE	FAIRHOPE	AL	36532	\$32.78	4/11/2016
1008673-110254717	1007729	110452876	109 PINETOP CIR W	FAIRHOPE	AL	36532	\$154.82	4/11/2016
1013568-117089506	1014846	117857406	19027 COUNTY RD 33 LOT 2	FAIRHOPE	AL	36532	\$2.97	4/12/2016
1009075-110092469	1015281	117856922	24001 WEATHERBEE PARK DR	DAPHNE	AL	36526	\$51.71	4/12/2016
1005584-106026597	1017209	119000769	6968 TWIN BEECH RD	FAIRHOPE	AL	36532	\$307.60	4/13/2016
1005372-104100456	1009034	110092660	361 SATSUMA ST	FAIRHOPE	AL	36532	\$106.00	4/13/2016
1016216-117611215	1014616	117327405	10825 COUNTY RD 48	FAIRHOPE	AL	36532	\$377.48	4/14/2016
1002329-103065465	1013239	117040895	16331 COUNTY RD 54	LOXLEY	AL	36551	\$18.13	4/14/2016
1003773-103625902	1009172	110092286	901 GAYFER AVE #1011	FAIRHOPE	AL	36532	\$715.35	4/15/2016
1007029-110018415	1006355	109020857	7323 NEW ERA RD	FAIRHOPE	AL	36532	\$342.84	4/15/2016
1013682-117126593	1016047	117857402	18901 HIGHLAND DR	FAIRHOPE	AL	36532	\$5.87	4/15/2016
1017144-119005731	1005341	104152697	15840 RED STAR DR LOT 12	SUMMERDALE	AL	36580	\$95.70	4/18/2016
1004020-103009515	1011580	115259123	30952 STANTON RD	SPANISH FORT	AL	36527	\$166.07	4/18/2016
1004020-103009520	1021991	123156982	119 WINDSOR CT	DAPHNE	AL	36526	\$0.04	4/18/2016
1011433-115147008	1005114	104125733	13937 FISH RIVER ACRES CR	FOLEY	AL	36535	\$63.14	4/18/2016
1000528-121021368	1008570	110014701	21844 WEST SIDE LOOP	SILVERHILL	AL	36576	\$592.34	4/20/2016
1015433-117610524	1022339	124513608	7078 WINDMERE PLACE	FAIRHOPE	AL	36532	\$299.87	4/20/2016
1022357-124023014	1018991	119198007	19092 HILTON LANE	FAIRHOPE	AL	36532	\$75.79	4/21/2016
1002174-102054121	1009151	110095853	9683 WINDMILL RD	FAIRHOPE	AL	36532	\$145.24	4/22/2016
1002176-102054602	1015447	117625508	1013 PICKETT ST	DAPHNE	AL	36526	\$27.09	4/25/2016
1013722-119004774	1006358	109024088	7296 NEW ERA DR #B	FAIRHOPE	AL	36532	\$237.75	4/27/2016
1014237-117265674	1005336	104106689	15885 HWY 59 LOT 17	FOLEY	AL	36535	\$123.99	4/29/2016
1006232-109026582	1007801	110017865	912 VAN AVE # 321	DAPHNE	AL	36526	\$298.70	5/2/2016
1005360-104106691	1015469	117610691	P O BOX 1243	FAIRHOPE	AL	36533	\$271.47	5/2/2016
1008042-110256907	1003759	103066568	7924 PARK PLACE DR N	MOBILE	AL	36608	\$27.54	5/2/2016
1017742-119258691	1006754	110005124	751 MORPHY AVE	FAIRHOPE	AL	36532	\$358.72	5/3/2016
1017846-119259809	1005334	104106008	15914 RED STAR DR LOT 6	SUMMERDALE	AL	36580	\$28.68	5/3/2016
1016108-117375161	1015064	117130570	18163 EUREKA DR	FOLEY	AL	36535	\$205.50	5/3/2016
1009086-110091497	1005999	109054511	65 S SCHOOL ST	FAIRHOPE	AL	36532	\$1,078.82	5/6/2016
1009085-110098493	1003172	103060808	10255 COUNTY RD 32 LOT 5	FAIRHOPE	AL	36532	\$9.15	5/6/2016
1009073-110452142	1021700	122050295	3412 8TH AVE S	BIRMINGHAM	AL	35222	(\$1.99)	5/9/2016
1006530-109050065	1013779	117125694	26549 HADLEY LN	LOXLEY	AL	36551	\$182.12	5/9/2016
1003708-103065264	1012016	115362004	37730 HWY 59 #B	BAY MINETTE	AL	36507	\$6.88	5/10/2016
1013811-117120742	1006208	109022301	603 MIDDLE ST	FAIRHOPE	AL	36532	\$411.53	5/11/2016
1022566-124002290	1022065	123008009	3721 PEPPER RIDGE DR	MOBILE	AL	36693	\$19.57	5/11/2016
1005361-104102667	1002308	103061682	15655 S GREENO RD	FAIRHOPE	AL	36532	\$98.35	5/13/2016
1006601-109068501	1006180	109020724	P O BOX 89	FAIRHOPE	AL	36533	\$271.08	5/16/2016
1015176-117620114	1004654	104104143	4650 WASHINGTON BLVD #307	ARLINGTON	VA	22201	\$177.48	5/16/2016
1022558-124003346	1002452	103066203	7532 RABBIT RUN #A	FAIRHOPE	AL	36532	\$84.98	5/16/2016
1005340-104100458	1004153	104001534	P.O. BOX 1154	FAIRHOPE	AL	36533	\$383.24	5/17/2016
1017193-119000525	1005365	104100512	8841 HILLSIDE CIR E	FOLEY	AL	36535	\$318.68	5/18/2016
1013777-117125561	1005374	104125910	21738 COUNTY RD 32	SUMMERDALE	AL	36580	\$58.41	5/19/2016
1003773-103626903	1015444	117611269	1411 MAPLE DR	DAPHNE	AL	36526	\$51.66	5/20/2016
1015443-117610486	1009085	110098493	8552 GARDEN CIR APT D	FAIRHOPE	AL	36532	\$230.46	5/20/2016
1015698-117621544	1013216	117040913	9556 COUNTY RD 34 #11	FAIRHOPE	AL	36532	\$27.63	5/24/2016
1007600-110125490	1009167	110098785	901 GAYFER AVE APT 1012	FAIRHOPE	AL	36532	\$2,554.90	5/24/2016
1009050-110125511	1009023	110091315	901 GAYFER AVE APT 118	FAIRHOPE	AL	36532	\$728.43	5/24/2016
1020707-120057001	1022140	124003271	22864 US HWY 98	FAIRHOPE	AL	36532	\$112.17	5/25/2016
1009151-110095941	1010364	112046909	810 FOREST DR	FAIRHOPE	AL	36532	\$144.95	5/25/2016
1000517-120094615	1001761	102012543	13150 DALE LANE LOT 12	FOLEY	AL	36535	\$48.20	5/27/2016
1018877-119005475	1002310	103065323	PO BOX 904	MAGNOLIA SPGS	AL	36555	\$52.04	5/27/2016

City of Fairhope

Write off Customer Terminated balances as of 6/01/2021

Customer Info	Property ID	Customer ID	Address 1	City	State	Zip Code	Total Unpaid	Stop Date
1020658-120051523	1013742	117526331	199 SPRING RUN SPT 102	FAIRHOPE	AL	36532	\$313.71	5/27/2016
1010086-111013191	1007218	110048524	10 CALL ST	FOLEY	AL	36536	\$71.33	5/27/2016
1011428-115145508	1009674	111046982	16608 KEENEY DR E	FAIRHOPE	AL	36532	\$94.95	6/1/2016
1009070-110025864	1018082	119259864	9104 MORPHY AVE #14	FAIRHOPE	AL	36532	\$0.67	6/1/2016
1017749-119856495	1008208	110096730	24104 HARVESTER DRIVE	LOXLEY	AL	36551	\$214.74	6/1/2016
1010853-114006000	1006330	109425601	7272 KIRKMAN LN	FAIRHOPE	AL	36532	\$642.17	6/2/2016
1011099-114020915	1018426	119003832	16690 COUNTY RD 3	FAIRHOPE	AL	36532	\$466.71	6/3/2016
1009112-110099563	1021689	122050039	PO BOX 216	MONTROSE	AL	36559	\$596.52	6/3/2016
1012509-116182548	1021982	123154400	P O BOX 1236	LOXLEY	AL	36551	\$155.15	6/6/2016
1017665-119213603	1013223	117040855	18080 RICHMOND ST	ROBERTSDALE	AL	36567	\$22.72	6/7/2016
1010856-114026646	1005973	108125479	259 EQUITY ST	FAIRHOPE	AL	36532	\$153.95	6/8/2016
1009047-110092829	1002611	103063302	16948 HEARTLAND CIRCLE	ROBERTSDALE	AL	36567	\$72.64	6/9/2016
1009958-111017176	1000864	101058901	407 AZALEA ST	FAIRHOPE	AL	36532	\$1,028.62	6/9/2016
1006748-110004028	1005366	104125908	18722 COUNTY RD 68	LOXLEY	AL	36551	\$143.77	6/15/2016
1000281-110004040	1013697	117100102	201 SPRINGRUN APT 47	FAIRHOPE	AL	36532	\$375.41	6/15/2016
1021981-123154317	1009146	110096785	50 16TH ST #3	TUSCALOOSA	AL	35401	\$57.36	6/16/2016
1021041-121004656	1008038	110025421	20765 BISHOP RD APT 119	FAIRHOPE	AL	36532	\$7.34	6/17/2016
1000052-102045617	1008558	110025976	8545 SOUTHWOOD CT B	FAIRHOPE	AL	36532	\$216.07	6/17/2016
1000995-101125466	1013228	117045939	9556 COUNTY RD 34 LOT 20	FAIRHOPE	AL	36532	\$63.14	6/17/2016
1000996-101126900	1020949	120090637	10 N SECTION ST #169	FAIRHOPE	AL	36532	\$504.84	6/17/2016
1013531-117855472	1006311	109024089	7341 KIRKMAN LANE	FAIRHOPE	AL	36532	\$163.37	6/17/2016
1008070-110025850	1002164	102003017	18592 GREENO RD	FAIRHOPE	AL	36532	\$357.62	6/20/2016
1005341-104152695	1014846	117857407	19027 COUNTY RD 33 LOT 6	FAIRHOPE	AL	36532	\$28.68	6/20/2016
1008073-110018084	1017774	119254650	8097 N LIMA RD	YOUNGSTOWN	OH	44514	\$2.80	6/20/2016
1001720-102042171	1013552	117126471	198 AUTUMN DR #12	FAIRHOPE	AL	36532	\$828.65	6/21/2016
1015450-117625891	1011092	114019800	3 POPE COURT	FAIRHOPE	AL	36532	\$1,955.56	6/22/2016
1024021-125008560	1024300	125830045	1007 RIVER POINTE DR	ALBANY	GA	31701	\$31.26	6/23/2016
1009056-110026544	1017826	119266503	12401 COPPER WOOD DR	FOLEY	AL	36535	\$235.38	6/27/2016
1018495-119002495	1022369	124152600	26831 CANAL RD STE 8	ORANGE BEACH	AL	36561	\$604.39	6/27/2016
1021696-122050299	1007824	110017966	952 SUMMERTON DR	FOLEY	AL	36535	\$365.89	6/27/2016
1021042-121004659	1017196	119256959	6843 TWIN BEECH LOT A	FAIRHOPE	AL	36532	\$142.95	6/28/2016
1006358-109024088	1010611	113030827	2255 DOUBLETOP ROAD	JAMESTOWN	TN	38556	\$44.14	6/28/2016
1015476-117611048	1004621	104125705	9061 ALPINE CT	SPANISH FORT	AL	36527	\$61.99	6/29/2016
1013530-117085692	1013133	117045263	1601 EAGLE DR	CANTONEMENT	FL	32533	\$9.15	6/30/2016
1006333-109020856	1009095	110096357	14549 SILVER OAKS LOOP	SILVERHILL	AL	36576	\$336.57	6/30/2016
1004982-104106392	1016942	118014305	14935 MAJESTIC OAKS DR	STAPLETON	AL	36578	(\$0.03)	7/1/2016
1009919-111069863	1006247	109023686	7711 LLOYD LN	FAIRHOPE	AL	36532	\$174.11	7/1/2016
1015814-117652485	1003729	103061538	16918 RIVER PARK RD	FAIRHOPE	AL	36532	\$57.39	7/1/2016
1011273-114036252	1001398	102040515	10137 CANAL CIRCLE	FAIRHOPE	AL	36532	\$9.15	7/1/2016
1006538-109065497	1011784	115312598	888 MANOO PLACE	DIAMONDHEAD	MS	39525	\$24.89	7/1/2016
1013747-117279602	1008380	110023941	P O BOX 9851	MOBILE	AL	36691	\$49.24	7/5/2016
1005300-104125624	1009257	111057008	553 JAN DRIVE	FAIRHOPE	AL	36532	\$916.07	7/5/2016
1009366-111237457	1014789	117425161	19520 COUNTY RD 33	FAIRHOPE	AL	36532	\$58.01	7/5/2016
1013225-117610959	1009918	111069872	1130 MARLEEN ST	HOUSTON	TX	77034	\$273.21	7/5/2016
1018568-119002132	1009075	110092469	9975 UNIVERSITY PKWY	PENSACOLA	FL	32514	\$54.63	7/5/2016
1001665-102050273	1013789	117325608	27670 US HWY 98 APT 65	DAPHNE	AL	36526	\$237.35	7/6/2016
1007207-110047564	1009331	111028572	710 S MOBILE ST #35	FAIRHOPE	AL	36532	\$160.86	7/6/2016
1018980-119125401	1009097	110023863	901 GAYFER AVE APT 528	FAIRHOPE	AL	36532	\$709.60	7/6/2016
1009921-111075494	1008864	110062793	728 RIDGEWAY CIRCLE	HOOVER	AL	35226	\$631.71	7/6/2016
1006368-109024091	1004447	104110530	19053 MEADOW CREST LN #33	SILVERHILL	AL	36576	\$53.94	7/8/2016
1002356-103066580	1018364	119002308	4136 FISCHER WAY	ATLANTA	GA	30341	\$41.35	7/8/2016
1009921-111075493	1016222	117611231	415 ELLINGTON AVE	FAIRHOPE	AL	36532	\$161.07	7/11/2016
1013793-117126618	1004271	104007002	208 FAIRHOPE AVE APT 4	FAIRHOPE	AL	36532	\$144.82	7/11/2016
1014482-117305446	1016102	117375483	20303 CADENA CREEK AVE	FAIRHOPE	AL	36532	\$171.57	7/12/2016
1011321-114125603	1013955	117786543	512 PARKWOOD AVE	DAPHNE	AL	36526	\$539.40	7/12/2016
1005332-104106522	1009508	111046033	408 FORESTER AVE	FAIRHOPE	AL	36532	\$7.29	7/14/2016
1004975-104125363	1012510	116180601	4737 CHESTER HARRIS RD	WOODLAWN	TN	37191	\$72.35	7/15/2016
1001674-102041180	1001417	102050529	10180 CANAL CIRCLE	FAIRHOPE	AL	36532	\$17.90	7/18/2016
1015469-117610683	1015577	117611200	9599 PLEASANT RD	DAPHNE	AL	36526	\$135.12	7/18/2016
1009783-111027473	1009148	110092746	23877 LIMERICK LANE	DAPHNE	AL	36526	\$108.29	7/18/2016
1005943-108036533	1009096	110025919	200 SUMMERFIELD CT	FOLEY	AL	36535	\$40.55	7/20/2016
1012001-115312563	1020052	119568970	3730 WESCOTT WAY	ATLANTA	GA	30319	\$113.66	7/20/2016

City of Fairhope

Write off Customer Terminated balances as of 6/01/2021

Customer Info	Property ID	Customer ID	Address 1	City	State	Zip Code	Total Unpaid	Stop Date
1015052-117130248	1001118	101062150	415 S SECTION ST	FAIRHOPE	AL	36532	\$980.52	7/22/2016
1005499-105952802	1013791	117185904	199 SPRING RUN RD APT 134	FAIRHOPE	AL	36532	\$160.66	7/25/2016
1020804-120076521	1009330	111026553	PO BOX 175	MONTROSE	AL	36559	\$105.53	7/27/2016
1019202-119005047	1000984	101125692	4 YACHT CLUB DR #70	DAPHNE	AL	36526	\$411.12	7/27/2016
1004267-104256982	1013272	117040901	8066-A MANLEY RD	FAIRHOPE	AL	36532	\$13.53	7/29/2016
1009918-111069856	1009180	110056567	901 GAYFER AVE #1113	FAIRHOPE	AL	36532	\$221.03	7/29/2016
1021035-121004560	1013438	117067482	1006 E 6TH ST	BAY MINETTE	AL	36507	\$418.23	8/1/2016
1007784-110017416	1013768	110096723	7684 TWIN BEECH ROAD #601	FAIRHOPE	AL	36532	\$154.54	8/1/2016
1017825-119257130	1011085	114018657	1500 NW 18TH STE 103	PORTLAND	OR	97209	\$89.82	8/1/2016
1022065-123008009	1006848	110125484	812 FAIRHOPE AVE	FAIRHOPE	AL	36532	\$175.53	8/1/2016
1006311-109024093	1008484	110014066	19825 QUAIL CREEK DR	FAIRHOPE	AL	36532	\$1,072.74	8/2/2016
1002397-103065537	1019360	119000879	9916 WINDMILL RD #14	FAIRHOPE	AL	36532	\$89.35	8/2/2016
1013686-117126611	1003737	103061234	5220 MOUNTAIN PASS RD	SOUTHSIDE	AL	35907	\$42.47	8/2/2016
1004623-104126906	1008362	110023967	13560 SW COUNTY ROAD 484	DUNNELLO	FL	34432	\$47.54	8/2/2016
1006570-109057305	1004717	104104770	12895 HONEY RD EXT	SUMMERDALE	AL	36580	\$24.08	8/2/2016
1003756-103456981	1009913	111037454	11745 WALKER RD	IRVINGTON	AL	36544	\$451.28	8/3/2016
1009310-111008508	1003331	103065334	9870 NIX LANE	FAIRHOPE	AL	36532	(\$5.78)	8/4/2016
1006106-109016528	1006937	110019024	751 MICHIGAN AVE	FAIRHOPE	AL	36532	\$590.93	8/5/2016
1008549-110018004	1009035	110045919	19948 COUNTY RD 13 #16	FAIRHOPE	AL	36532	\$191.87	8/8/2016
1015571-117611145	1009117	110098498	400 PARK AVE #1102	FOLEY	AL	36535	\$124.59	8/8/2016
1009508-111046033	1006368	109024085	7248 NEW ERA #B	FAIRHOPE	AL	36532	\$420.10	8/8/2016
1023305-124002980	1009151	110095941	901 GAYFER AVE #921	FAIRHOPE	AL	36532	\$876.15	8/8/2016
1009366-111237453	1017205	119856001	18924 DENTON LN #9	FAIRHOPE	AL	36532	\$101.46	8/9/2016
1009282-111028515	1016238	117625407	116 PETZ AVE	FAIRHOPE	AL	36532	\$292.81	8/10/2016
1014457-117375175	1012504	116159002	5 LANCERS LANE	SPANISH FORT	AL	36527	\$31.41	8/11/2016
1021076-121008508	1009013	110096794	2663 HOLLEY BROOK DR	MOBILE	AL	36605	\$669.40	8/12/2016
1007100-110022655	1009131	110024592	22631 COLONIAL PKWY #230	KATY	TX	77449	\$332.47	8/12/2016
1009251-111007028	1004092	103024628	312 FAIRHOPE AVE	FAIRHOPE	AL	36532	\$569.50	8/12/2016
1009069-110023952	1009058	110014942	901 GAYFER AVE #321	FAIRHOPE	AL	36532	\$147.90	8/15/2016
1013562-117086558	1006248	109026640	PO BOX 534	POINT CLEAR	AL	36564	\$65.45	8/15/2016
1013586-117130616	1019964	119568741	10 N SECTION SR #155	FAIRHOPE	AL	36532	\$373.32	8/15/2016
1006159-109026595	1006665	109066585	PO BOX 1760	FAIRHOPE	AL	36533	\$202.12	8/15/2016
1001746-102042380	1013236	117040931	9556 COUNTY RD 34 #6	FAIRHOPE	AL	36532	\$48.21	8/16/2016
1017072-118102499	1011420	115137763	7563 WHISPERING PINES RD	DAPHNE	AL	36526	\$9.81	8/16/2016
1013844-117103298	1000523	121125690	PO BOX 471	POINT CLEAR	AL	36564	\$204.63	8/16/2016
1015500-117611212	1021981	123154317	118 WINDSOR DR	DAPHNE	AL	36526	\$81.55	8/17/2016
1001354-102040499	1009405	111013311	418 ROSA AVE	FAIRHOPE	AL	36532	\$1,067.03	8/18/2016
1010314-112021505	1013233	117040922	9556 COUNTY RD 34 LOT 3	FAIRHOPE	AL	36532	\$26.88	8/18/2016
1000236-109016447	1006623	109085476	9471 TWIN BEECH RD	FAIRHOPE	AL	36532	\$545.18	8/18/2016
1003385-103061223	1013603	117081133	633 COGSWELL AVE APT A	PELL CITY	AL	35125	\$248.74	8/19/2016
1010610-113056989	1017973	119524697	904 CLARK AVE #1-106	BAY MINETTE	AL	36507	\$48.80	8/19/2016
1009129-110023979	1009783	111027473	28233 BAY BRANCH DR	DAPHNE	AL	36526	\$641.08	8/19/2016
1011064-114028470	1002344	103063318	30173 A OSPREY LN	ROBERTSDALE	AL	36567	\$17.19	8/23/2016
1009127-110085003	1005587	106021135	133 LAKE FRONT DR APT 403	DAPHNE	AL	36526	\$543.18	8/23/2016
1017107-119003829	1012243	116042501	7241 HAMPSHIRE DR	CEDAR RAPIDS	IA	52402	\$9.81	8/23/2016
1006536-109057484	1003497	103062816	10720 COUNTY RD 32 LOT 8	FAIRHOPE	AL	36532	\$160.98	8/24/2016
1008866-110065878	1013218	117054875	17257-A COUNTY RD 9	SUMMERDALE	AL	36580	\$39.01	8/25/2016
1005358-104106670	1021646	122004504	7299 HELTON DR	FOLEY	AL	36535	\$73.80	8/25/2016
1016119-117375172	1003486	103066656	8508 COUNTY RD 24	FAIRHOPE	AL	36532	\$36.29	8/26/2016
1003995-103025703	1021184	121030730	PO BOX 286	POINT CLEAR	AL	36564	\$176.86	8/26/2016
1000248-109024058	1005329	104154805	15972 RED STAR DR LOT 1	SUMMERDALE	AL	36580	\$145.88	8/29/2016
1013220-117040545	1003470	103061581	14185 COUNTY RD 13	FAIRHOPE	AL	36532	\$89.84	8/30/2016
1001868-102055698	1014906	117090504	12609 CLAY CITY RD	FAIRHOPE	AL	36532	\$169.74	8/30/2016
1013533-117085476	1004329	104100514	26831 CANAL RD STE 8	ORANGE BEACH	AL	36561	\$378.45	8/31/2016
1013941-117180068	1002820	103060199	9008 ZELDA ST	PENSACOLA	FL	32514	\$9.15	8/31/2016
1009013-110096750	1009047	110092829	901 GAYFER AVE #324	FAIRHOPE	AL	36532	\$472.21	8/31/2016
1001743-102042382	1006083	109016499	34 WINTERHAVEN COURT	FAIRHOPE	AL	36532	\$652.07	9/1/2016
1018531-119567804	1018085	119564231	9104 MORPHY AVE #24	FAIRHOPE	AL	36532	\$64.21	9/1/2016
1008624-110015300	1017683	119000995	7216 TWIN BEECH RD	FAIRHOPE	AL	36532	\$482.48	9/7/2016
1001330-102040357	1021076	121008508	16894 SCENIC HWY 98	FAIRHOPE	AL	36532	\$692.49	9/7/2016
1002160-102052372	1018898	119006082	9531 BAY MEADOWS DR	FAIRHOPE	AL	36532	\$197.61	9/8/2016
1002805-103065261	1006332	109016012	7419 NEW ERA RD	FAIRHOPE	AL	36532	\$259.19	9/8/2016

City of Fairhope

Write off Customer Terminated balances as of 6/01/2021

Customer Info	Property ID	Customer ID	Address 1	City	State	Zip Code	Total Unpaid	Stop Date
1009825-111048500	1017711	119257143	7118 TWIN BEECH RD	FAIRHOPE	AL	36532	\$106.26	9/8/2016
1006733-110018001	1013775	117125625	830 US HWY 98 APT 117	DAPHNE	AL	36526	\$6.32	9/9/2016
1008548-110096595	1023896	125930337	P O BOX 7319	SPANISH FORT	AL	36577	\$751.96	9/9/2016
1005482-105010037	1017768	119268743	1317 HARDWOOD DR W	GULF SHORES	AL	36542	\$26.56	9/12/2016
1014136-117268000	1009192	110095810	901 GAYFER AVE APT 1221	FAIRHOPE	AL	36532	\$1,238.25	9/12/2016
1013659-117452806	1013238	117045612	4804 WOODRIDGE COURT	ROCKFORD	IL	61108	\$45.48	9/12/2016
1000644-125862022	1019351	119255466	82 PLANTATION POINTE #294	FAIRHOPE	AL	36532	\$481.60	9/13/2016
1009513-111016814	1017802	119207482	1061 VALLEY VIEW CT	MOBILE	AL	36695	\$81.76	9/13/2016
1024295-125830050	1004074	103063074	PO BOX 397	SILVERHILL	AL	36576	\$637.57	9/14/2016
1009095-110096357	1004479	104100125	20110 COUNTY RD 49	SILVERHILL	AL	36576	(\$5.78)	9/14/2016
1004992-104106662	1017144	119005739	19114 WILSON LANE	FAIRHOPE	AL	36532	\$592.08	9/15/2016
1009145-110092798	1002566	103061476	1602 TEALWOOD COURT	KELLER	TX	76248	(\$2.46)	9/16/2016
1013488-117066035	1023761	125900000	9613 SHERWOOD CT	DAPHNE	AL	36526	\$103.81	9/19/2016
1005857-108030049	1023727	125901192	525 SUBLETT RD	HICKMAN	KY	42050	\$25.09	9/20/2016
1006919-110025712	1005361	104102665	25014 CO RD LOT 56	ELBERTA	AL	36530	\$117.63	9/21/2016
1003759-103066568	1007608	110017923	P O BOX 139	ALMA	CO	80420	\$21.89	9/22/2016
1003663-103065525	1010108	111025451	829 N SECTION ST	FAIRHOPE	AL	36532	\$639.45	9/23/2016
1002308-103061655	1012454	116125400	17 CAISSON TRACE	SPANISH FT	AL	36527	\$225.40	9/26/2016
1013057-116500239	1009129	110023979	901 GAYFER AVE #727	FAIRHOPE	AL	36532	\$676.62	9/26/2016
1005241-104110504	1015486	117625432	31065 STATE HWY 225 #203	SPANISH FORT	AL	36527	\$39.01	9/26/2016
1005346-104100238	1001668	102052059	PO BOX 1141	FAIRHOPE	AL	36532	\$142.86	9/28/2016
1017198-119026583	1005348	104125767	15784 RED STAR DR LOT 46	SUMMERDALE	AL	36580	\$230.92	9/30/2016
1005990-109002035	1013681	117854723	PO BOX 157	FAIRHOPE	AL	36532	\$99.65	9/30/2016
1014650-117315060	1017811	119256929	13494 B PENDIX RD	SUMMERDALE	AL	36580	\$159.93	10/3/2016
1016423-117782249	1013557	117589602	198 AUTUMN DR #58	FAIRHOPE	AL	36532	\$131.48	10/3/2016
1013230-117040298	1009092	110091738	901 GAYFER AVE #514	FAIRHOPE	AL	36532	\$376.22	10/4/2016
1018456-119256392	1005759	107029237	PO BOX 403	FAIRHOPE	AL	36533	\$609.21	10/4/2016
1024019-125256981	1002858	103060795	10210 WOODMERE DR	FAIRHOPE	AL	36532	\$157.37	10/4/2016
1021991-123156982	1003469	103061429	204 GOLF TERRACE	DAPHNE	AL	36526	\$27.32	10/4/2016
1013784-117125578	1007232	110047977	220 1/2 VALLEY RD	CHICKASAW	AL	36611	\$311.14	10/5/2016
1016676-117046931	1008673	110254717	11593 E SALMON DR	FLORAL CITY	FL	34436	\$493.90	10/5/2016
1006211-109025685	1009491	111026548	418 VOLANTA AVE	FAIRHOPE	AL	36532	\$677.10	10/7/2016
1018277-119006505	1011175	114017897	22781 HILLWOOD RD	FAIRHOPE	AL	36532	\$620.86	10/10/2016
1013239-117040895	1013854	117122231	1497 ZENNER DRIVE	COLUMBUS	OH	43207	\$132.72	10/10/2016
1004271-104007002	1006832	110025551	803 PROSPECT AVE	FAIRHOPE	AL	36532	\$514.35	10/10/2016
1015640-117625437	1013779	117125695	2665 HAMPTON PARK CIRCLE	FOLEY	AL	36535	\$360.55	10/11/2016
1009915-111075845	1013562	117086556	198 AUTUMN DR LOT 6	FAIRHOPE	AL	36532	\$391.23	10/14/2016
1013333-117058470	1000905	101045807	135 LAKE FRONT DR	DAPHNE	AL	36526	\$171.45	10/14/2016
1016761-117047251	1014767	117377051	19940 COUNTRY RD 33	FAIRHOPE	AL	36532	\$44.08	10/18/2016
1009094-110095876	1015640	117625437	200 PALMER DR F3	DAPHNE	AL	36526	\$9.39	10/18/2016
1018686-119254827	1001982	102050668	158 VIVIAN LOOP	FAIRHOPE	AL	36532	\$35.85	10/18/2016
1013536-117854620	1013551	117079106	1017 MULBERRY ST	WATERLOO	IA	50703	\$318.89	10/20/2016
1015577-117611200	1008652	110030105	8281 GAYFER RD EXT #1B	FAIRHOPE	AL	36532	\$416.51	10/24/2016
1009128-110095794	1009365	111017016	702 N SECTION ST	FAIRHOPE	AL	36532	\$3,990.24	10/26/2016
1005973-108125477	1015447	117625513	10208 MISSION TRACE	FAIRHOPE	AL	36532	\$103.36	10/27/2016
1002098-102057023	1009080	110095471	901 GAYFER AVE APT 412	FAIRHOPE	AL	36532	\$370.23	10/28/2016
1007843-110017109	1011007	114013489	602 S CHURCH ST	FAIRHOPE	AL	36532	\$434.65	10/28/2016
1005333-104106579	1009461	111015119	512 VOLANTA AVE	FAIRHOPE	AL	36532	\$431.07	10/28/2016
1008070-110025802	1013679	117125558	18924 DENTON LN	FAIRHOPE	AL	36532	\$811.82	10/31/2016
1021529-121085474	1018335	119002374	30429 LONNIE BLVD	WESTLAND	MI	48185	\$31.68	10/31/2016
1005334-104106004	1017201	119255764	6843 TWIN BEECH RD #E	FAIRHOPE	AL	36532	\$225.61	10/31/2016
1013222-117040935	1003772	103061162	PO BOX 162	ALICEVILLE	AL	35442	\$39.01	11/1/2016
1011255-114026514	1009069	110023952	1009 27TH ST	NICEVILLE	FL	32578	\$66.42	11/1/2016
1009104-110125527	1013285	117056982	19070 GREENO RD	FAIRHOPE	AL	36532	\$112.52	11/3/2016
1009022-110045898	1013533	117085480	198 AUTUMN DR LOT 26	FAIRHOPE	AL	36532	\$585.91	11/3/2016
1017747-119855602	1001554	102055702	12690 DOMINION DR	FAIRHOPE	AL	36532	\$44.56	11/3/2016
1005347-104125736	1022047	123132004	117 RIDGEWOOD DR	DAPHNE	AL	36526	\$78.39	11/3/2016
1020526-120047609	1001250	102045113	26214 POLLARD RD	DAPHNE	AL	36526	(\$0.71)	11/4/2016
1013423-117066274	1015470	117610705	21400 STATE HWY 181 #3	FAIRHOPE	AL	36532	\$82.66	11/4/2016
1009015-110045897	1010856	114026645	246 BURGUNDY AVE	FAIRHOPE	AL	36532	\$106.46	11/5/2016
1019521-119004917	1003720	103065468	11950 COUNTY RD 32 LOT 7	FAIRHOPE	AL	36532	\$10.08	11/7/2016
1012903-116184445	1005848	108012607	110 FAIRHOPE AVE #3	FAIRHOPE	AL	36532	\$621.88	11/7/2016

City of Fairhope

Write off Customer Terminated balances as of 6/01/2021

Customer Info	Property ID	Customer ID	Address 1	City	State	Zip Code	Total Unpaid	Stop Date
1005019-104126618	1014967	117130598	1001 CAROLINE AVE	DAPHNE	AL	36526	\$289.09	11/8/2016
1015080-117126624	1017601	119001722	19092 HILTON LN	FAIRHOPE	AL	36532	\$552.61	11/10/2016
1016992-118065421	1007808	110018162	1909 HIGH VALLEY CT #206	LAS VEGAS	NV	89128	\$356.10	11/10/2016
1020052-119568970	1005472	105012518	1025 E CANAL DR	GULF SHORES	AL	36542	\$495.04	11/10/2016
1005646-107028503	1013222	117040935	9556 COUNTY RD 34 #15	FAIRHOPE	AL	36532	\$282.67	11/10/2016
1009123-110125518	1004017	103009533	411 A JOHNSON AVE	FAIRHOPE	AL	36532	\$387.19	11/10/2016
1013216-117040839	1013517	117080129	198 AUTUMN DR LOT 37	FAIRHOPE	AL	36532	\$419.36	11/16/2016
1016336-117785504	1012086	115313136	13630 WHITE LN	STAPLETON	AL	36578	\$77.52	11/16/2016
1006623-109085476	1015847	21095	P O BOX 1661	FAIRHOPE	AL	36533	\$268.69	11/16/2016
1021612-122006003	1005857	108030049	P O BOX 3212	ORANGE BEACH	AL	36561	\$711.13	11/16/2016
1018472-119866901	1014846	117857409	19027 COUNTY RD 33 LOT 17	FAIRHOPE	AL	36532	\$62.56	11/17/2016
1009613-111044215	1006071	109016486	509 NICHOLS AVE UNIT A	FAIRHOPE	AL	36532	\$113.80	11/17/2016
1002452-103066203	1006257	109026862	7940 GREENO LN	FAIRHOPE	AL	36532	\$3,395.33	11/17/2016
1015525-117611126	1017205	119856002	18924 DENTON LN #9	FAIRHOPE	AL	36532	\$36.11	11/17/2016
1005114-104125733	1000877	101065281	7 AZALEA COURT	FAIRHOPE	AL	36532	\$1,087.69	11/18/2016
1017748-119858903	1024191	125830043	7012 JANE ELIZABETH DR SE	OWENS X RDS	AL	35763	\$34.69	11/18/2016
1001746-102042351	1001743	102042382	18924 DENTON LN #9	FAIRHOPE	AL	36532	\$39.01	11/18/2016
1017687-119000908	1005355	104100346	19600 OBRIEN AVE	ROBERTSDALE	AL	36567	(\$5.78)	11/18/2016
1008126-110026641	1010987	114013207	16533 DANNE RD	FAIRHOPE	AL	36532	\$131.62	11/21/2016
1003499-103061585	1008038	110025426	20765 BISHOP RD APT 119	FAIRHOPE	AL	36532	\$138.71	11/21/2016
1022008-123159632	1017198	119026588	2112 MCMILLIAN AVE 2D	BAY MINETTE	AL	36507	\$54.95	11/23/2016
1005300-104125614	1022998	124526910	10081 ROSEWOOD LN	DAPHNE	AL	36526	\$32.03	11/29/2016
1017201-119255746	1005349	104125721	15772 RED STAR DR #47	SUMMERDALE	AL	36580	\$78.06	11/29/2016
1013531-117856908	1006036	109014402	612 MAXWELL AVE	DAPHNE	AL	36526	\$322.47	11/29/2016
1017001-118066590	1016943	118014503	837 HICKMAN AVE E	KINSTON	AL	36453	\$580.96	11/30/2016
1012460-116132541	1014616	117327406	10825 COUNTY RD 48	FAIRHOPE	AL	36532	\$96.33	11/30/2016
1000864-101058901	1011428	115145508	28260 US HWY 98	DAPHNE	AL	36526	\$65.39	11/30/2016
1017678-119257108	1002346	103065531	14782 S GREENO RD #11	FAIRHOPE	AL	36532	\$39.01	12/2/2016
1019718-119006027	1008572	110025979	8564 GARDEN CIR APT 2	FAIRHOPE	AL	36532	\$204.12	12/2/2016
1016676-117046925	1014895	117601015	3332 MAIN ST APT 3	SPRINGFIELD	OR	97478	\$257.37	12/5/2016
1005364-104100495	1009183	110092830	300 SAINT CHARLES CT	FAIRHOPE	AL	36532	\$374.70	12/5/2016
1009161-110023695	1013536	117854616	198 AUTUMN DR #22	FAIRHOPE	AL	36532	\$864.61	12/6/2016
1007626-110025913	1024254	125863254	25 S LAFAYETTE ST	MOBILE	AL	36604	\$176.54	12/6/2016
1017026-118100204	1013235	117040930	9556 COUNTY RD 34 LOT 5	FAIRHOPE	AL	36532	\$37.65	12/6/2016
1009146-110096670	1017846	119259809	8552 GARDEN CIRCLE APT D	FAIRHOPE	AL	36532	\$94.56	12/7/2016
1015064-117130570	1018530	119574818	107 BRENTWOOD DR	DAPHNE	AL	36526	\$63.00	12/7/2016
1023932-125932168	1006765	110005403	691 CHEROKEE AVE SE	ATLANTA	GA	30315	\$11.06	12/13/2016
1017416-119001183	1007731	110018119	108 HOMESTEAD VLG # 4	FAIRHOPE	AL	36532	\$316.75	12/13/2016
1021039-121015800	1008124	110023719	11880 COUNTY RD 48	FAIRHOPE	AL	36532	\$849.55	12/14/2016
1003596-103065394	1017178	119254792	PO BOX 1857	FAIRHOPE	AL	36533	\$117.12	12/14/2016
1001733-102045135	1006772	110025786	991 TRABUCO CIR	COSTA MESA	CA	92627	\$375.27	12/15/2016
1012233-116036506	1003464	103062729	158108 A GREENO RD	FAIRHOPE	AL	36532	\$135.24	12/15/2016
1009125-110093057	1012303	116241209	38134 SALEM AVE	ZEPHYR HILLS	FL	33541	(\$4.02)	12/19/2016
1008647-110036524	1007048	110017116	50 SPRING RUN DR APT 206	FAIRHOPE	AL	36532	\$240.08	12/21/2016
1006300-109045215	1017764	119257132	7684 TWIN BEECH RD #1206	FAIRHOPE	AL	36532	\$2.80	12/22/2016
1009340-111026612	1007821	110017983	8132 GAYFER RD EXT #1001	FAIRHOPE	AL	36532	\$260.80	12/22/2016
1002094-102050901	1009907	111065007	16051 NORTH AVE	SILVERHILL	AL	36576	(\$7.85)	12/22/2016
1000984-101125692	1008540	110012562	21081 BISHOP RD APT 3	FAIRHOPE	AL	36532	\$431.50	12/27/2016
1010575-113026852	1007760	110452881	P O BOX 70233	MOBILE	AL	36670	\$3,782.46	12/27/2016
1017761-119256810	1009060	110092763	1640 HIGHROCK RD	HAYDEN	AL	35079	\$142.67	12/27/2016
1013697-117100102	1000976	101028460	70 S SECTION ST UNIT 1	FAIRHOPE	AL	36532	\$215.63	12/28/2016
1009920-111452602	1008111	110017830	21165 MEADOWBROOK DR	FAIRHOPE	AL	36532	\$77.47	12/29/2016
1015448-117655232	1007846	110017395	16740 LOWER LAC CT	BAY MINETTE	AL	36507	\$98.72	12/29/2016
1004950-104106539	1003227	103063285	26594 DEAN CT S	DAPHNE	AL	36526	\$46.78	12/29/2016
1004567-104103528	1016103	117452002	21548 LAKEBREEZE	STCLAIRE SHS	MI	48082	\$121.89	12/30/2016
1018082-119259864	1009023	110091325	1212 NEWMAN'S TRAIL	HENDERSONVILLE	TN	37075	\$86.49	1/3/2017
1009034-110092660	1014154	117266994	P O BOX 2912	GULF SHORES	AL	36547	\$154.55	1/3/2017
1000009-101104009	1004759	104125426	19510 HUNTING CLUB RD	SEMINOLE	AL	36574	\$72.41	1/3/2017
1009461-111015119	1010927	107002407	203 NICHOLS AVE	FAIRHOPE	AL	36532	\$9.30	1/3/2017
1006330-109425601	1009112	110099563	13626 LITEWOOD DR	HUDSON	FL	34669	\$396.42	1/3/2017
1014952-117137801	1004327	104100515	13366 CATHEDRAL LANE	SILVERHILL	AL	36576	\$68.87	1/3/2017
1000828-101053608	1013244	117040926	108 NORTHGATE DR	LOXLEY	AL	36551	(\$5.78)	1/4/2017

City of Fairhope

Write off Customer Terminated balances as of 6/01/2021

Customer Info	Property ID	Customer ID	Address 1	City	State	Zip Code	Total Unpaid	Stop Date
1020974-120068566	1003241	103063042	16405 GAINESWOOD DR S	FAIRHOPE	AL	36532	\$37.16	1/4/2017
1013699-117115803	1005364	104200495	15979 RED STAR DR LOT 30	SUMMERDALE	AL	36580	\$243.91	1/4/2017
1013578-117090070	1005358	104106684	5120 REED ST	FORT WAYNE	IN	46806	\$235.12	1/4/2017
1015750-117611150	1010770	113056990	406 GRAND AVE	FAIRHOPE	AL	36532	\$112.54	1/4/2017
1017105-119257408	1020974	120068567	960 DAUPHIN ST	MOBILE	AL	36604	\$245.23	1/4/2017
1009171-110097495	1007279	110095866	103 RONFORTH ST	FAIRHOPE	AL	36532	\$1,394.97	1/5/2017
1009365-111017016	1018040	119003782	20386 COUNTY RD 13	FAIRHOPE	AL	36532	\$14.22	1/5/2017
1013236-117040917	1005798	108059742	163 GASTON AVE	FAIRHOPE	AL	36532	\$462.90	1/9/2017
1013940-117180062	1012244	116045804	2265 TANGLEWOOD CIR NE	ATLANTA	GA	30345	\$99.30	1/10/2017
1007250-110023859	1005361	104102667	60 FOURTH ST	PARRISH	AL	35580	\$9.15	1/11/2017
1020975-120075486	1000920	101031123	308 GASTON AVE	FAIRHOPE	AL	36532	\$216.09	1/13/2017
1018851-119003496	1023932	125932168	19648 ADAMS DR	SUMMERDALE	AL	36580	\$116.38	1/13/2017
1014773-117378450	1023579	124089744	6780 S WINDING BROOK DR	FAIRHOPE	AL	36532	\$103.20	1/17/2017
1001672-102055700	1006570	109057305	613 JOHNSON AVE	FAIRHOPE	AL	36532	\$11.76	1/17/2017
1004021-103011019	1003499	103061585	25764 PONDEROSSA FARM RD	ROBERTSDALE	AL	36567	\$9.15	1/18/2017
1015098-117782363	1023792	125930290	7985 DEERWOOD DR	DAPHNE	AL	36526	\$1,616.30	1/19/2017
1024297-125830042	1013559	117126639	413 JACOBEE CT	BAY MINETTE	AL	36507	\$569.39	1/19/2017
1004674-104104362	1001273	102045886	10918 COUNTY RD 1	FAIRHOPE	AL	36532	\$90.58	1/20/2017
1008636-110052401	1005964	108028453	3109 W BERWICK	CLAREMORE	OK	74017	\$819.53	1/20/2017
1015953-117040568	1015752	117626593	20901 LAWRENCE RD #3	FAIRHOPE	AL	36532	\$57.39	1/24/2017
1014840-117402353	1017810	119257230	782 SERPENTINE DR	FAIRHOPE	AL	36532	\$112.12	1/24/2017
1017089-119459862	1013216	117040941	9556 COUNTY RD 34 LOT 11	FAIRHOPE	AL	36532	\$21.99	1/24/2017
1012233-116036505	1017824	119258941	7684 TWIN BEECH RD #405	FAIRHOPE	AL	36532	\$2.80	1/30/2017
1004463-104102700	1008993	110090453	215 JEFF DAVIS ST	FAIRHOPE	AL	36532	\$589.96	1/30/2017
1009257-111056999	1013759	117126636	27559 CLAIBORNE CIRCLE	DAPHNE	AL	36526	\$43.52	1/31/2017
1013929-117104508	1013619	117040797	10 COTTAGE DR	FAIRHOPE	AL	36532	\$182.88	1/31/2017
1013529-117079119	1009918	111069874	806 N GREENO RD LOT 7	FAIRHOPE	AL	36532	\$669.32	2/1/2017
1019246-119564817	1005991	109025463	401 N MOBILE	FAIRHOPE	AL	36532	\$184.55	2/1/2017
1008572-110025979	1009608	111044502	309 GAYFER COURT #A	FAIRHOPE	AL	36532	\$297.94	2/1/2017
1018694-119257061	1015421	117782108	21747 ST HWY 181	FAIRHOPE	AL	36532	(\$5.78)	2/1/2017
1009151-110009578	1009913	111037456	806 N GREENO RD LOT 3	FAIRHOPE	AL	36532	\$316.02	2/1/2017
1010108-111025451	1013747	117279602	199 SPRING RUN APT 103	FAIRHOPE	AL	36532	\$392.49	2/1/2017
1005506-105000319	1013859	117103187	950 SPRINGRUN DR APT 26	FAIRHOPE	AL	36532	\$112.72	2/1/2017
1005547-106008507	1013685	117156902	201 SPRINGRUN DR APT 30	FAIRHOPE	AL	36532	\$1,049.07	2/2/2017
1011398-115137840	1014136	117268000	904 OAK HILL RD	POPLARVILLE	MS	39470	\$18.86	2/2/2017
1012585-116181409	1004267	104256992	7904 ST CHARLES APT A2	NEW ORLEANS	LA	70118	\$157.25	2/3/2017
1015521-117625497	1000862	101046988	114 GEORGIA AVE	DAPHNE	AL	36526	\$151.65	2/6/2017
1001741-102042352	1018568	119002132	729 TRUXTON ST	FAIRHOPE	AL	36532	\$600.97	2/6/2017
1004019-103025462	1006159	109026595	19758 STATE HWY 181	FAIRHOPE	AL	36532	\$757.80	2/6/2017
1024333-125930176	1018555	119002174	103 WHITNEY CT	FORT MILL	SC	29715	\$2,787.63	2/8/2017
1023563-124002075	1013093	116195680	10687 CREST HAVEN DR	SPANISH FT	AL	36527	\$9.81	2/11/2017
1000890-101059611	1018204	119200508	18512 UPPER COLUMBAS RD	GORDO	AL	35466	\$341.84	2/13/2017
1004327-104100515	1016343	117785645	5799 SOUTHLAND DR # 5303	MOBILE	AL	36693	\$49.87	2/13/2017
1000976-101028460	1021991	123156983	119 WINDSOR CT	DAPHNE	AL	36526	\$128.02	2/13/2017
1000854-101055315	1007279	110095952	5608 PARK ST	SATSUMA	AL	36572	\$97.00	2/13/2017
1001162-101061033	1021640	122006500	PO BOX 1437	FAIRHOPE	AL	36533	\$0.03	2/13/2017
1012473-116119514	1002325	103066549	8862 US HWY 98	FAIRHOPE	AL	36532	\$137.63	2/16/2017
1012244-116045804	1003766	103070858	901 GAYFER AVE APT 1112	FAIRHOPE	AL	36532	\$241.19	2/17/2017
1004635-104021305	1015953	117040568	198 PEMBERTON LOOP	FAIRHOPE	AL	36532	\$380.15	2/17/2017
1019225-119237851	1007229	110017028	20489 STATE HWY 181	FAIRHOPE	AL	36532	\$45.19	2/18/2017
1003056-103072307	1019718	119006027	7550 NEW ALBANY CONDIT RD	NEW ALBANY	OH	43054	\$784.84	2/20/2017
1014846-117857407	1015226	124089746	6780 SOUTH WINDING BROOK	MONTROSE	AL	36532	\$144.77	2/20/2017
1022155-124001838	1004359	104125778	P O BOX 798	SEQUATCHIE	TN	37374	\$0.44	2/21/2017
1007689-110023241	1019248	119004688	450 PARK AVE #702	FOLEY	AL	36535	\$649.99	2/22/2017
1003673-103064051	1017783	119257200	16155 PINE GROVE RD EXT S	BAY MINETTE	AL	36507	\$2.80	2/23/2017
1013259-117040791	1018320	119125000	130 KEMPER LN	FAIRHOPE	AL	36532	\$58.02	2/24/2017
1004964-104106365	1006231	109026593	PO BOX 8214	MOSS POINT	MS	39562	\$828.82	2/24/2017
1009106-110096007	1008180	110020769	20934 NOBLEMAN DR	FAIRHOPE	AL	36532	\$218.93	2/24/2017
1016047-117857402	1000491	119004152	10955 QUINLEY RD	BAY MINETTE	AL	36507	\$165.92	3/1/2017
1014906-117090502	1013536	117854620	198 AUTUMN DR #22	FAIRHOPE	AL	36532	\$184.31	3/2/2017
1009057-110092622	1004988	104106418	12992 HOPPER RD	SUMMERDALE	AL	36580	\$14.22	3/3/2017
1013607-117081092	1005581	106023680	3122 W 21ST CT	PANAMA CTY	FL	32405	\$131.44	3/6/2017

City of Fairhope

Write off Customer Terminated balances as of 6/01/2021

Customer Info	Property ID	Customer ID	Address 1	City	State	Zip Code	Total Unpaid	Stop Date
1021199-121035402	1002329	103065465	5505 SAEGERT CT	KILLEEN	TX	76541	\$27.32	3/6/2017
1022967-124003355	1009086	110091497	26920 POLLARD RD #816	DAPHNE	AL	36526	\$207.77	3/6/2017
1009140-110095424	1017160	119000370	1160 S MCCORD RD APT X3	HOLLAND	OH	43528	\$284.63	3/7/2017
1000175-104125750	1013228	117045945	9556 COUNTY RD 34 #20	FAIRHOPE	AL	36532	\$68.87	3/9/2017
1003352-103062253	1003475	103063036	11830 MALLARD LN	FAIRHOPE	AL	36532	(\$1.40)	3/9/2017
1017599-119213650	1009121	110095940	2017 JESSICA WAY	NAVARRE	FL	32566	\$335.82	3/9/2017
1008993-110090453	1010615	113034580	3125 JIM BUSBY RD	THEODORE	AL	36582	\$545.48	3/10/2017
1014418-117305374	1021282	121029716	23755 HWY 59 N	ROBERTSDALE	AL	36567	\$568.72	3/10/2017
1009913-111037452	1002814	103060145	16869 LEA CIRCLE	FAIRHOPE	AL	36532	\$462.88	3/13/2017
1009610-111044513	1015089	117130632	812 CRYSTAL WELLS COURT S	FAIRHOPE	AL	36532	\$359.49	3/13/2017
1018664-119066537	1010495	113012025	103 PIER AVE	FAIRHOPE	AL	36532	\$908.16	3/14/2017
1017567-119256954	1009192	110095822	23710 PORTWOOD LN	ZACHARY	LA	70791	\$175.07	3/14/2017
1004278-104006565	1008574	110025534	8552 GARDEN CIRCLE APT B	FAIRHOPE	AL	36532	\$184.12	3/14/2017
1006181-109058206	1006630	109071003	508 MORPHY AVE	FAIRHOPE	AL	36532	\$42.89	3/15/2017
1003472-103075423	1022875	124001427	70 WASHINGTON SQ	SALEM	MA	01970	\$746.89	3/16/2017
1013219-117045907	1005337	104106633	207 POWELL AVE	BAY MINNETTE	AL	36507	\$137.18	3/16/2017
1023467-124002823	1012585	116181408	1 SOLDIERS ROUTE	SPANISH FORT	AL	36527	\$2.11	3/16/2017
1009121-110095916	1001427	102040494	5798 RIVIERA DR	MILTON	FL	32583	\$39.01	3/20/2017
1015447-117625505	1013852	117103157	P O BOX 730	GRAND BAY	AL	36541	\$241.72	3/20/2017
1006716-110003650	1005477	105012603	521 EQUALITY AVE	FAIRHOPE	AL	36532	\$499.20	3/22/2017
1006857-110015140	1006315	109025640	7277 KIRKMAN LANE	FAIRHOPE	AL	36532	\$417.45	3/23/2017
1003172-103060808	1006334	109020855	7301 KIRKMAN LANE #C	FAIRHOPE	AL	36532	\$709.21	3/23/2017
1001775-102050988	1019327	119005053	3730 SAND POINT WAY NE	SEATTLE	WA	98105	\$9.27	3/24/2017
1002129-102026534	1018838	119003203	19767 CARDNIAL DR LOT 27	FAIRHOPE	AL	36532	\$106.84	3/24/2017
1013587-117125565	1000850	101059620	517 S STREET	BEDFORD	IN	47421	\$462.83	3/24/2017
1024305-125869742	1013368	117059100	9851 COUNTY RD 11	FAIRHOPE	AL	36532	\$214.82	3/28/2017
1015485-117625452	1006211	109025685	918 BAY AVE	MOBILE	AL	36505	\$354.41	3/28/2017
1003759-103066561	1003478	103065228	8830 COUNTY RD 24	FAIRHOPE	AL	36532	\$65.27	3/30/2017
1014193-117265720	1022016	123081003	160 COUNTRY CLUB DR	DAPHNE	AL	36526	\$25.37	3/31/2017
1017700-119003710	1015757	117611281	20861 LAWRENCE RD	FAIRHOPE	AL	36532	\$70.53	3/31/2017
1013498-117065801	1005943	108036533	22519 MAIN ST	FAIRHOPE	AL	36532	\$93.37	3/31/2017
1010284-112018510	1005482	105010037	516 EQUALITY AVE	FAIRHOPE	AL	36532	(\$70.77)	3/31/2017
1022999-124526911	1003056	103072307	P O BOX 9753	MOBILE	AL	36691	(\$1.66)	3/31/2017
1015456-117611098	1009398	111013485	PO BOX 683	FAIRHOPE	AL	36532	\$174.52	4/3/2017
1005359-104125519	1005364	104125911	8405 BELEW DR	MCKINNEY	TX	75071	\$29.15	4/3/2017
1013536-117854610	1004335	104100501	13233 CATHEDRAL LANE	SILVERHILL	AL	36576	\$65.23	4/3/2017
1005817-108012365	1009825	111048514	108 OAKWOOD AVE	FAIRHOPE	AL	36532	\$178.25	4/3/2017
1014918-117125585	1014948	117130033	500 JACKSON ST #904	DAPHNE	AL	36526	\$182.97	4/3/2017
1015435-117610468	1013562	117086558	198 AUTUMN DR LOT 6	FAIRHOPE	AL	36532	\$317.37	4/3/2017
1011612-115285400	1007622	110018157	108 HOMESTEAD APT 21	FAIRHOPE	AL	36532	\$51.04	4/3/2017
1006878-110015144	1013681	117854728	17830 BALDWIN FARMS #511	ROBERTSDALE	AL	36567	\$187.53	4/4/2017
1006333-109020858	1004843	104105880	14761 COUNTY RD 9	SUMMERDALE	AL	36580	\$57.87	4/4/2017
1013748-117120750	1000533	121079500	16903 BRIGDOOR TRI	GULF SHORES	AL	36542	\$14.22	4/4/2017
1001275-102041031	1013590	117081047	43 COTTAGE DR	FAIRHOPE	AL	36532	\$76.64	4/4/2017
1001982-102050668	1003496	103015962	10720 COUNTY RD 32 LOT 6	FAIRHOPE	AL	36532	\$7.35	4/5/2017
1015610-117621300	1007373	110050418	561 FAIRHOPE AVE	FAIRHOPE	AL	36532	\$22.81	4/5/2017
1013225-117610987	1001749	102042385	PO BOX 207	FAIRHOPE	AL	36533	\$33.62	4/5/2017
1012213-116011205	1020975	120075486	24143 LIMERICK LN	DAPHNE	AL	36526	\$315.81	4/5/2017
1016661-117042006	1013234	117045709	9556 COUNTY RD 34 LOT 4	FAIRHOPE	AL	36532	\$311.85	4/6/2017
1009180-110056563	1012610	116055463	816 ARTILLERY RANGE W	SPANISH FT	AL	36527	\$200.88	4/7/2017
1016455-117782360	1012746	116185480	P O BOX 4698	LOGAN	UT	84323	(\$9.81)	4/7/2017
1008940-110068451	1008641	110125507	8281 GAYFER RD EXT #4A	FAIRHOPE	AL	36532	\$14.52	4/10/2017
1001734-102042397	1008912	110069862	8295A MORPHY AVE	FAIRHOPE	AL	36532	\$190.91	4/10/2017
1005329-104154805	1011404	115137820	28189 SEVENTH AVE	DAPHNE	AL	36526	(\$226.93)	4/10/2017
1023577-124087417	1009207	110096722	20637 BLUEBERRY LN	FAIRHOPE	AL	36532	\$335.79	4/10/2017
1007517-110025469	1001714	102042158	10739 SOUTHERN RIDGE DR	KEITHVILLE	LA	71047	\$68.87	4/12/2017
1004236-104006505	1001661	102050937	13856 COUNTY RD 13 UNIT A	FAIRHOPE	AL	36532	\$290.95	4/12/2017
1004017-103009533	1021976	123154508	110 WINDSOR DR	DAPHNE	AL	36526	\$117.56	4/12/2017
1023896-125930337	1009020	110096584	138 APPOMATOX DR	DAPHNE	AL	36526	\$1,531.14	4/12/2017
1006537-109057010	1005352	104106534	15825 RED STAR DR BOX 17	SUMMERDALE	AL	36580	(\$5.78)	4/13/2017
1004171-104002150	1021696	122050299	P O BOX 247	SEMMES	AL	36575	\$327.90	4/14/2017
1017183-119123609	1010610	113056989	2304 MAIN ST	DAPHNE	AL	36526	\$125.45	4/14/2017

City of Fairhope

Write off Customer Terminated balances as of 6/01/2021

Customer Info	Property ID	Customer ID	Address 1	City	State	Zip Code	Total Unpaid	Stop Date
1008981-110098756	1008538	110025553	13157 MORIAH DR	SUMMERDALE	AL	36580	\$266.05	4/14/2017
1001875-102038451	1007376	110055693	15 S SUMMIT	FAIRHOPE	AL	36532	(\$0.36)	4/17/2017
1005355-104100346	1019529	119004611	7133 DENVER DR	BILOXI	MS	39532	\$1,260.27	4/17/2017
1001336-102041120	1012600	116055557	2459 RICHARD AVE	MOBILE	AL	36606	\$29.57	4/17/2017
1023515-124002930	1015525	117611126	11433 WARRIE CREEK ALLEY	FAIRHOPE	AL	36532	\$127.20	4/17/2017
1012070-115370401	1001665	102050588	9201 COUNTY RD 11	FAIRHOPE	AL	36532	\$259.66	4/18/2017
1005312-104125535	1005374	104125913	15830 BROOK WAY DR LOT 44	SUMMERDALE	AL	36580	\$198.60	4/18/2017
1003413-103062517	1015201	117620085	21806 LINN RIDGE DR	FAIRHOPE	AL	36532	\$141.18	4/18/2017
1010440-113003011	1005357	104100278	15830 BROOKWAY LOT 44	SUMMERDALE	AL	36580	\$60.45	4/18/2017
1008208-110096730	1009104	110125527	605 S DOBSON AVE #24	BAY MINETTE	AL	36507	\$162.88	4/19/2017
1016455-117782357	1006537	109057010	256 LIBERTY ST	FAIRHOPE	AL	36532	\$983.19	4/19/2017
1017415-119000787	1017993	119003980	P O BOX 175	FAIRHOPE	AL	36532	\$149.34	4/20/2017
1017216-119001044	1016455	117782360	PO BOX 2213	FAIRHOPE	AL	36532	\$157.16	4/20/2017
1014166-117265486	1004692	104102111	16457 COUNTY RD 9	SUMMERDALE	AL	36580	\$105.64	4/21/2017
1015486-117625432	1009910	111065211	22108 HILL N DALE DR W	SILVER HILL	AL	36576	\$28.94	4/21/2017
1001665-102050139	1009909	111065261	22108 HILL N DALE DR W	SILVER HILL	AL	36576	\$299.76	4/21/2017
1024344-125930088	1005200	104107903	16182 ZENITH DR	LOXLEY	AL	36551	\$14.22	4/21/2017
1003464-103062729	1004813	104101680	15619 COUNTY RD 9	SUMMERDALE	AL	36580	\$765.73	4/21/2017
1017734-119236516	1005360	104106691	19580 CORAL LN	ROBERTSDALE	AL	36567	\$78.07	4/21/2017
1016719-117042185	1005371	104125911	2020 FIELDSTONE PKWY#900	FRANKLIN	TN	37069	\$14.22	4/22/2017
1013542-117079502	1005373	104125909	15876 BROOK WAY DR LOT 40	SUMMERDALE	AL	36580	\$207.04	4/24/2017
1011600-115021542	1005561	106021541	3 POPE CT	FAIRHOPE	AL	36532	\$47.96	4/24/2017
1009060-110092763	1005560	106023664	3 POPE CT	FAIRHOPE	AL	36532	\$207.98	4/24/2017
1008038-110025426	1018081	119004335	9104 MORPHY AVE LOT 15	FAIRHOPE	AL	36532	\$3.05	4/25/2017
1000905-101045807	1012921	116181591	11 SAILORS COVE	SPANISH FT	AL	36527	\$179.28	4/25/2017
1001228-102040980	1014650	117315060	11633 COUNTY RD 48	FAIRHOPE	AL	36532	\$294.04	4/25/2017
1013918-117104079	1008080	110017940	101 CHATHAM LOOP	DAPHNE	AL	36526	\$74.72	4/26/2017
1012466-116452870	1015018	117125633	133 LAKEFRONT DR #3004	DAPHNE	AL	36526	\$245.45	4/27/2017
1010838-114025709	1002817	103065386	16915 LEA CIRCLE	FAIRHOPE	AL	36532	\$7.35	4/28/2017
1013742-117526331	1002563	103065453	314 STAVE MILL RD	FAIRHOPE	AL	36532	\$48.76	4/28/2017
1013547-117079123	1001249	102045114	PO BOX 2252	GULF SHORES	AL	36547	\$38.00	5/1/2017
1018987-119256965	1014420	117325502	301 S JUPITER RD #811	ALLEN	TX	75002	\$63.26	5/1/2017
1006665-109066585	1015280	117856936	113 BRIAR HILL WAY	TROY	AL	36079	\$1.26	5/1/2017
1013236-117040894	1003596	103065394	12226 MYRTLE ST	FAIRHOPE	AL	36532	\$44.87	5/1/2017
1005973-108125410	1019150	119005325	P O BOX 454	FAIRHOPE	AL	36533	\$503.65	5/2/2017
1021976-123154508	1013682	117126637	179 BAYVIEW DR	DAPHNE	AL	36526	\$714.29	5/2/2017
1009918-111069868	1007233	110017028	20489 STATE HWY 181	FAIRHOPE	AL	36532	\$80.44	5/2/2017
1013542-117079505	1017937	119003163	20029 LEA BROOK PLACE	FAIRHOPE	AL	36532	\$123.73	5/3/2017
1004773-104155261	1004973	104106678	12934 COVENTRY CT	SUMMERDALE	AL	36580	\$7.35	5/4/2017
1005346-104100251	1007374	110050415	559 FAIRHOPE AVE #1	FAIRHOPE	AL	36532	\$0.01	5/4/2017
1018530-119574816	1015555	117611297	10220 GAYFER RD EXT	FAIRHOPE	AL	36532	\$55.44	5/5/2017
1010668-113032560	1013718	117135493	201 SPRING RUN APT 38	FAIRHOPE	AL	36532	\$393.18	5/8/2017
1006937-110019024	1013463	117652157	P O BOX 190610	MOBILE	AL	36619	\$3.50	5/8/2017
1006922-110019062	1020044	119826954	P O BOX 915	ORANGE BEACH	AL	36561	\$139.32	5/9/2017
1000977-101009549	1006180	109020731	20800 BLUEBERRY LN	FAIRHOPE	AL	36532	\$367.58	5/9/2017
1008940-110068450	1022010	123162502	550 STUART ST	DAPHNE	AL	36526	\$1,551.61	5/10/2017
1008901-110067605	1015098	117782363	20025 WALLACE LN	ROBERTSDALE	AL	36567	\$31.61	5/10/2017
1023769-125901182	1009134	110047583	901 GAYFER AVE #811	FAIRHOPE	AL	36532	\$582.33	5/11/2017
1020949-120090637	1013220	117040545	9556 COUNTY RD 34 LOT 13	FAIRHOPE	AL	36532	\$99.44	5/11/2017
1007056-110016992	1011548	115229564	7601 DOUGLAS ST	SPANISH FORT	AL	36527	\$201.76	5/12/2017
1015491-117610553	1014834	117610927	19096 FAIRGROUND RD # F-4	ROBERTSDALE	AL	36567	\$698.34	5/12/2017
1012293-116625409	1011391	115137851	7499 PINE HILL RD	DAPHNE	AL	36526	\$196.91	5/12/2017
1012293-116625412	1009754	111035468	10825 COUNTY RD 48	FAIRHOPE	AL	36532-45	\$648.00	5/14/2017
1020972-120069852	1016046	117856163	3000 TOWN CENTER AVE #335	SPANISH FORT	AL	36527	\$33.32	5/18/2017
1008673-110254693	1015500	117611214	11751 RED BARN RD	FAIRHOPE	AL	36532	\$9.86	5/18/2017
1011578-115265875	1008969	110024009	205 PATRICIAN ST	FAIRHOPE	AL	36532	\$786.67	5/21/2017
1008574-110025534	1015443	117610486	10252 MISSION TRACE #13	FAIRHOPE	AL	36532	\$63.79	5/21/2017
1021974-123256901	1021053	119856002	656 NICHOLS AVE	FAIRHOPE	AL	36532	\$81.58	5/23/2017
1005357-104100208	1017067	118103116	12462 SQUIRREL DR	SPANISH FT	AL	36527	\$11.91	5/25/2017
1009614-111048510	1015537	117611090	300 FAIRHOPE AVE SUITE B	FAIRHOPE	AL	36532	\$79.63	5/25/2017
1006311-109024089	1012420	116632541	27121 BIT AND SPUR DR	DAPHNE	AL	36526	\$40.11	5/30/2017
1006331-109023705	1016403	117784755	11047 MOCKINGBIRD LANE	FAIRHOPE	AL	36532	\$23.10	5/30/2017

City of Fairhope

Write off Customer Terminated balances as of 6/01/2021

Customer Info	Property ID	Customer ID	Address 1	City	State	Zip Code	Total Unpaid	Stop Date
1011677-115326908	1009926	111452135	806 N GREENO RD LOT 17	FAIRHOPE	AL	36532	\$297.75	5/31/2017
1004705-104101306	1014847	117402380	19027 COUNTY RD 33 #3	FAIRHOPE	AL	36532	\$88.66	6/1/2017
1005357-104100203	1012016	115362005	13440 RYLAND ST	STAPLETON	AL	36578	\$63.54	6/1/2017
1005990-109002036	1017692	119236500	19076 BELL RD	FAIRHOPE	AL	36532	\$4.85	6/1/2017
1003496-103015963	1001514	102042293	914 CADILAC AVE	DAUPHIN ISLAND	AL	36528	\$11.73	6/1/2017
1021022-121004642	1006665	109066588	29150 LAKE FOREST BLVD	DAPHNE	AL	36526	\$321.67	6/6/2017
1001956-102050346	1017567	119256954	P O BOX 1117	ORANGE BEACH	AL	36561	\$10.30	6/6/2017
1000999-101109062	1001554	102055718	18326 S SECTION ST	FAIRHOPE	AL	36532	\$224.67	6/7/2017
1004978-104107856	1017102	119236594	6109 HENSHAW RD	FAIRHOPE	AL	36532	\$74.45	6/7/2017
1003726-103060664	1005964	108028454	254 GEORGE ST	FAIRHOPE	AL	36532	\$386.67	6/8/2017
1009020-110096584	1002779	103652947	P O BOX 1667	FAIRHOPE	AL	36532	\$29.15	6/8/2017
1003469-103061429	1002160	102052372	719 HIGHWAY 27	WHITWELL	TN	37397	\$160.39	6/8/2017
1009916-111075844	1001753	102045618	PO BOX 725	MAGNOLIA SPRG	AL	36555	\$169.17	6/13/2017
1002455-103066567	1014343	117325635	P O BOX 158	FAIRHOPE	AL	36533	\$125.78	6/14/2017
1018628-119001870	1018148	119003925	29150 LK FOREST BLVD #301	DAPHNE	AL	36526	\$143.83	6/15/2017
1018086-119006072	1003503	103065379	10720 COUNTY RD 32 LOT 12	FAIRHOPE	AL	36532	\$59.76	6/19/2017
1009184-110098474	1021442	121082500	1814 GRISSTONE CT	ATLANTA	GA	30307	\$36.45	6/19/2017
1003721-103070557	1004020	103009520	7396 KIRKMAN LN	FAIRHOPE	AL	36532	\$1,454.08	6/20/2017
1005036-104106703	1007832	110018201	8132 GAYFER RD EXT #1401	FAIRHOPE	AL	36532	\$427.99	6/22/2017
1014616-117327402	1018052	119452104	9040 MORPHY AVE LOT 11	FAIRHOPE	AL	36532	\$413.21	6/27/2017
1005846-108025473	1005973	108125410	259 EQUITY ST	FAIRHOPE	AL	36532	\$694.24	6/27/2017
1003502-103061104	1016176	117611120	8955 LAKE VIEW DR	FAIRHOPE	AL	36532	\$79.73	7/5/2017
1013859-117103187	1022999	124526911	133 SANDY SHOAL LOOP	FAIRHOPE	AL	36532	\$149.58	7/6/2017
1008912-110069854	1015015	117023581	412 BELLE CHASE COURT S	FAIRHOPE	AL	36532	\$1,899.24	7/9/2017
1013234-117045704	1008070	110025862	10664 DUNMORE DR	DAPHNE	AL	36526	\$592.34	7/10/2017
1001162-101061025	1009071	110092841	50 S CHURCH ST UNIT 13	FAIRHOPE	AL	36532	\$131.48	7/11/2017
1006334-109020855	1006332	109016015	PO BOX 974	FAIRHOPE	AL	36532	\$186.70	7/12/2017
1004483-104103002	1004236	104006505	9356 COUNTY RD 24	FAIRHOPE	AL	36532	\$417.14	7/14/2017
1015082-117130299	1006475	109026830	394 S INGLESIDE ST	FAIRHOPE	AL	36532	\$125.55	7/16/2017
1012303-116241209	1018476	119567483	18678 FOUNDERS DR	FAIRHOPE	AL	36532	\$306.72	7/17/2017
1000483-119003762	1022050	123135501	1137 PARLANGE DR	BATON ROUGE	LA	70806	\$158.32	7/17/2017
1007229-110017028	1004242	104126608	PO BOX 256	MONTROSE	AL	36559	\$8.22	7/19/2017
1007233-110017028	1014518	117325465	20371 NORTHWOOD ST	FAIRHOPE	AL	36532	\$204.54	7/25/2017
1021697-122058960	1002142	102030790	54 N CHURCH ST APT 21	FAIRHOPE	AL	36532	\$183.32	7/27/2017
1010990-114028453	1004262	104256921	715 RIVER RT	MAGNOLIA SPRINGS	AL	36555	\$454.03	7/28/2017
1017144-119005725	1010962	112012006	211 PINECREST AVE	FAIRHOPE	AL	36532	\$395.69	7/31/2017
1001306-102040495	1011600	115021545	30729 WALLING RD	SPANISH FORT	AL	36527	\$3.58	7/31/2017
1017774-119254650	1005584	106026597	12654 ALABAMA ST UNIT F6	ELBERTA	AL	36530-26	\$33.34	8/1/2017
1004279-104006758	1010314	112021505	302 N SUMMIT ST	FAIRHOPE	AL	36532	\$618.96	8/1/2017
1015953-117040555	1014418	117305385	4884 HILARITA CIRCLE	PACE	FL	32570	\$93.78	8/6/2017
1009481-111025490	1005340	104100497	10340 S JUNIPER ST LOT 21	FOLEY	AL	36535-92	\$74.84	8/9/2017
1006730-110004038	1004154	104165202	5 N CHURCH ST #D	FAIRHOPE	AL	36532	\$40.17	8/10/2017
1011370-115135529	1005393	105035827	58 N SECTION ST	FAIRHOPE	AL	36532	\$874.29	8/11/2017
1017190-119000843	1022002	123159604	215 ALPINE ST	MOBILE	AL	36611-24	\$84.15	8/24/2017
1013662-117127404	1021568	121070805	PO BOX 843	POINT CLEAR	AL	36564	\$11.49	8/29/2017
1011250-114023676	1003493	103060990	10720 COUNTY RD 32 #3	FAIRHOPE	AL	36532	\$76.92	9/4/2017
1005759-107027450	1014838	117425872	9104 MORPHY AVE LOT 9	FAIRHOPE	AL	36532-36	\$27.11	9/5/2017
1017687-119001380	1005362	104106666	15943 RED STAR DR LOT 27	SUMMERDALE	AL	36580	\$64.36	9/5/2017
1004836-104155697	1005506	105000319	455 MAGNOLIA AVE	FAIRHOPE	AL	36532	\$393.10	9/8/2017
1004674-104104364	1010730	113034831	11 FRIDAY LANE	NEEDHAM	AL	36915	\$7.87	9/12/2017
1001611-102050943	1018698	119003030	21333 STATE HWY 181	FAIRHOPE	AL	36532	\$62.18	9/15/2017
1013655-117854785	1015925	117045882	273 COUNTRY LANE	MOBILE	AL	36608	\$23.05	9/17/2017
1006524-109048523	1004247	104251620	19 S SUMMIT ST APT 1	FAIRHOPE	AL	36532	\$64.88	9/26/2017
1018530-119574818	1011255	114026514	PO BOX 22	POINT CLEAR	AL	36564	\$1,031.88	10/1/2017
1008538-110025553	1020185	119258929	P O BOX 1241	FAIRHOPE	AL	36533	\$229.94	10/5/2017
1011792-115312179	1004674	104104365	19132 HOUSTON AVE	FAIRHOPE	AL	36532	\$114.87	10/9/2017
1009913-111037454	1010074	111017475	848 SEACLIFF DR	FAIRHOPE	AL	36532	\$461.04	10/15/2017
1005361-104102658	1010071	111017523	848 SEA CLIFF DRIVE	FAIRHOPE	AL	36532	\$395.03	10/15/2017
1007556-110025784	1010073	111017525	848 SEACLIFF DRIVE	FAIRHOPE	AL	36532	\$474.94	10/15/2017
1006848-110125484	1000828	101053608	650 GAYFER AVE	FAIRHOPE	AL	36532	\$67.99	10/15/2017
1022127-124000050	1006068	109021379	351 S SCHOOL ST	FAIRHOPE	AL	36532	\$403.00	10/16/2017
1009934-111078540	1006498	109031501	367 YOUNG ST	FAIRHOPE	AL	36532	\$430.81	10/20/2017

City of Fairhope

Write off Customer Terminated balances as of 6/01/2021

Customer Info	Property ID	Customer ID	Address 1	City	State	Zip Code	Total Unpaid	Stop Date
1020976-120068466	1007819	110017943	110 GARDENIA ST	P C BEACH	FL	32407	\$75.23	10/23/2017
1000558-123004005	1001349	102056489	PO DRAWER 1004	FAIRHOPE	AL	36533	\$127.85	11/9/2017
1010871-114006423	1000248	109024058	319 MYRTLE AVE	FOLEY	AL	36535	\$32.72	11/14/2017
1001118-101062150	1001734	102042397	9650 HWY 98 LOT 21	FAIRHOPE	AL	36532	\$11.73	11/14/2017
1009148-110092746	1006368	109024091	7248 B NEW ERA RD	FAIRHOPE	AL	36532	\$506.45	11/17/2017
1009343-111029587	1020632	120052155	24375 US HWY 98	FAIRHOPE	AL	36532	\$23.22	11/30/2017
1013779-117125694	1002098	102057029	10715 COUNTY RD 24 LOT 2	FAIRHOPE	AL	36532	\$31.26	12/5/2017
1015226-124089746	1005175	104107837	32468 STATE HIGHWAY 59	LOXLEY	AL	36551	\$29.24	12/8/2017
1017160-119000370	1009366	111237457	406 MILLER AVE	FAIRHOPE	AL	36532	\$63.03	12/28/2017
1021375-121056701	1012651	116190529	5 RANGER RD	SPANISH FORT	AL	36527	\$56.78	1/2/2018
1006071-109016436	1014840	117402389	9104 MORPHY AVE LOT 8	FAIRHOPE	AL	36532	\$17.92	1/28/2018
1019278-119004751	1014873	117400055	22678 CANAL RD #7	ORANGE BEACH	AL	36561	\$29.39	2/6/2018
1007622-110018157	1019285	119004820		FAIRHOPE	AL	36532	\$1,378.61	2/8/2018
1009912-111066587	1011433	115147009	28850 HWY 98 SUITE 200	DAPHNE	AL	36526	\$87.17	2/27/2018
1006733-110017999	1005348	104125775	15784 RED STAR DR LOT 46	SUMMERDALE	AL	36580	\$101.05	3/1/2018
1000401-115298742	1018086	119006072	9104 MORPHY AVE 25	FAIRHOPE	AL	36532	\$560.51	3/1/2018
1003723-103061288	1004019	103025462	418 FAIRHOPE AVE	FAIRHOPE	AL	36532	\$793.11	3/6/2018
1013681-117854723	1005297	104110222	18183 ALICE LN	SUMMERDALE	AL	36580	\$335.76	3/9/2018
1018915-119569820	1003976	103061568	12215 COUNTY RD 32	FAIRHOPE	AL	36532	\$338.87	3/14/2018
1010770-113056990	1002349	103063359	14782 S GREENO RD LOT 4	FAIRHOPE	AL	36532	\$37.65	3/19/2018
1007218-110048524	1009056	110026544	901 GAYFER AVE #327	FAIRHOPE	AL	36532	\$117.46	3/26/2018
1010925-114026620	1023563	124002075	650 GAYFER AVENUE	FAIRHOPE	AL	36532	\$23.22	3/29/2018
1004153-104001534	1006330	109425602	7409 NEW ERA DR	FAIRHOPE	AL	36532	\$1,201.54	4/26/2018
1009105-110254699	1001754	102045624	9650 US HWY 98 LOT 15	FAIRHOPE	AL	36532	\$9.15	5/8/2018
1021580-121067503	1013548	117079111	15160 STATE HIGHWAY 104	SILVERHILL	AL	36576	\$955.58	6/5/2018
1013619-117040797	1012091	115398011	37730 STATE HWY 59, UNIT B	BAY MINETTE	AL	36507	\$342.25	6/8/2018
1004717-104104770	1014846	117857410	19027 COUNTY RD 33 LOT 2	FAIRHOPE	AL	36532	\$1.04	6/10/2018
1010615-113038457	1014836	117402390	19027 COUNTY RD 33 #14	FAIRHOPE	AL	36532	\$29.39	7/2/2018
1005184-104152608	1006358	109024090	PO BOX 594	FAIRHOPE	AL	36533	\$157.28	7/6/2018
1009032-110096744	1017678	119257108	198 AUTUMN DR LOT 24	FAIRHOPE	AL	36532	\$129.23	7/17/2018
1009100-110093066	1017416	119001183	PO BOX 371	POINT CLEAR	AL	36564	\$14.93	7/17/2018
1000258-109057322	1017190	119000843	PO BOX 755	FAIRHOPE	AL	36533	\$49.58	7/18/2018
1002133-102035715	1018087	119574810	9104 MORPHY AVE LOT 26	FAIRHOPE	AL	36532	\$29.00	7/20/2018
1009305-111255600	1006229	109053008	18963 MALONE RD	FAIRHOPE	AL	36532	\$201.28	7/23/2018
1004836-104155695	1018983	119199977	9625 TWIN BEECH RD #3	FAIRHOPE	AL	36532	\$147.22	7/24/2018
1001775-102050996	1017700	119003848	19206 BELL RD	FAIRHOPE	AL	36532	\$377.25	7/24/2018
1004479-104100125	1023565	124088506	515 MAIN ST	DAPHNE	AL	36526	\$170.68	7/26/2018
1006596-109062500	1003497	103062823	198 AUTUMN DR #21	FAIRHOPE	AL	36532	\$7.35	8/24/2018
1009754-111035468	1003496	103015963	10720 COUNTY RD 32 #6	FAIRHOPE	AL	36532	\$27.35	8/27/2018
1017686-119000925	1005113	104125552	654 SUNRISE CIRCLE	PELL CITY	AL	35125-38	\$98.73	8/29/2018
1017595-119001709	1015435	117610468	10193 MISSION TRACE	FAIRHOPE	AL	36532	\$43.84	9/13/2018
1009104-110125521	1006248	109026635	7661 LLOYDS LANE	FAIRHOPE	AL	36532	\$98.73	9/14/2018
1021763-122050347	1006248	109026635	7695 LLOYD LANE	FAIRHOPE	AL	36532	\$142.18	9/14/2018
1000540-122056405	1012314	116240103	2 LEE CIRCLE	SPANISH FORT	AL	36527	\$115.47	10/3/2018
1008040-110026582	1015521	117625497	20900 HWY 181	FAIRHOPE	AL	36532	\$14.54	10/17/2018
1002325-103066549	1003768	103070857	12144 MEADOW RD #24	FAIRHOPE	AL	36532	\$72.80	12/11/2018
1005696-107045261	1006367	109042265	510 1/2 ERA DR	FAIRHOPE	AL	36532	\$267.71	1/24/2019
1020974-120068567	1006311	109024093	656 NICHOLS ST	FAIRHOPE	AL	36532	\$68.87	1/24/2019
1010176-111055841	1017148	119000385	PO BOX 1531	POINT CLEAR	AL	36564	\$186.98	3/13/2019
1015106-117782346	1017153	119000462	6435 ROMIE HARRIS LANE	FAIRHOPE	AL	36532	\$107.73	3/13/2019
1015537-117611090	1018851	119003496	19704 THOMPSON HALL RD#18	FAIRHOPE	AL	36532	\$36.09	3/14/2019
1022047-123132004	1023577	124087417	2019 MARKERT BLVD SE	CEDAR RAPIDS	IA	52403	\$38.94	4/3/2019
1000473-117782000	1003385	103061223	14052 PECAN LANE	FAIRHOPE	AL	36532	\$42.03	4/18/2019
1014947-117138744	1017686	119000925	18932 BRACY LN	FAIRHOPE	AL	36532	\$383.70	6/13/2019
1006734-110017990	1007250	110023710	PO BOX 1333	DAPHNE	AL	36526	\$341.45	7/24/2019
1008540-110012547	1007837	110017858	8132 GAYFER RD EXT #1501	FAIRHOPE	AL	36532	\$442.38	8/9/2019
1013567-117125534	1009920	111452607	25089 POMPANO DR	ELBERTA	AL	36530	\$79.29	9/10/2019

\$614,485.95 Totals

\$201,141.19 2016-2019