

**City of Fairhope**

**Bid 005-21 Fairhope Docks Bulkhead Repairs - FEMA 4563**

**CITY of FAIRHOPE  
FAIRHOPE, ALABAMA**

## ADVERTISEMENT

Sealed Proposals will be received by the City of Fairhope of Baldwin County, Alabama, in the City of Fairhope offices, 555 South Section St. Fairhope, Alabama, until 10:00 A.M. Tuesday, April 20, 2021 then publicly opened thereafter, for furnishing all labor and materials, and performing all work required by the City of Fairhope and described as follows:

### **Bid 005-21 Fairhope Docks Bulkhead Repairs – FEMA 4563**

The project will consist of labor, equipment, and material necessary to rebuild, reinforce and/or repair City-owned bulkheads, piers and docks at the City's Marina on Fly Creek damaged by Hurricane Sally (DR-4563-AL) on September 16, 2020. One hundred and twenty (120) calendar days are allowed for the construction of the project.

Plans, Drawings and Specifications are on file and may be viewed in the Purchasing Department of the City of Fairhope, Alabama, located at 555 S. Section Street. Copies may be obtained from the City of Fairhope, at no cost to the Contractor. Bid advertisement, addenda and other related documents will be posted on the City of Fairhope website [www.fairhopeal.gov](http://www.fairhopeal.gov). Questions or comments pertaining to this bid must be presented in writing and sent as e-mail to the attention of the Purchasing Manager, Dee Dee Brandt, P.O. Drawer 429, 555 South Section St., Fairhope, AL 36532, e-mail: [deedeeb@fairhopeal.gov](mailto:deedeeb@fairhopeal.gov), no later than seven (7) days prior to the bid opening or will be forever waived.

All Bids must be on blank bid forms provided in the Bid documents. Bids shall be accompanied by a BID SECURITY equal to 5% (percent) of the bid price, but in no event more than \$50,000.00. BID SECURITY shall be in the form of a Bid Bond signed by a Bonding company authorized to do business in the State of Alabama, or a Cashier's Check payable to the City of Fairhope. NO BID SECURITY is required on bids less than \$10,000.00.

A **Performance Bond** in the form and terms approved by the City of Fairhope in an amount not less than the sum of the bid will be required at the signing of the CONTRACT, and in addition, a **Labor and Materials Bond** in the form and terms approved by the City of Fairhope in an amount not less than fifty percent (50%) of the CONTRACT price insuring payment for all labor and materials.

### **A non-mandatory pre-bid meeting will be held at the Public Works Building, 555 S. Section Street, Fairhope, AL, Tuesday, April 13, 2021 at 9:00 a.m.**

The City of Fairhope is an Equal Opportunity Employer and requires that all contractors comply with the Equal Employment Opportunity laws and the provisions of the Contract documents in this regard. The CITY also encourages and supports the utilization of Minority Business Enterprises on this and all public bids.

All bids, with their guarantee when required), must be enclosed in a sealed, opaque envelope, clearly identified on the outside as "**Sealed Bid**" with **Bid Name, Bid Number, City of Fairhope's name and address, and the Bidder's name, address, and General Contractor's License Number (Mandatory by State law)**. Each bid must be in a separate envelope. Bids made out in pencil will not be accepted. Failure to observe the instructions contained herein will constitute grounds for rejection of your bid. The CITY reserves the right to accept or reject all bids, or any portions thereof, and to waive informalities, and to furnish any item of material or work to change the amount of the **CONTRACT**, whichever is in the best interest of the City of Fairhope.

The **CONTRACTOR** must furnish to the City of Fairhope at the time of the signing of the **CONTRACT**, a Certificate of Insurance coverage as provided in the contract documents which will include Comprehensive Insurance, Contractor's Automobile, and where applicable, Owner's Protective Liability insurance, Subcontractor's Public Liability and Property Damage Insurance. The company that is awarded the bid must have Workman's Compensation Insurance on all of its employees if work is to be performed on City of Fairhope premises. General Liability Insurance, specifying coverage, must be maintained to hold the City of Fairhope harmless in the event of an accident. See bid packet for details.

No bids will be considered unless the Bidder, whether resident or non-resident of Alabama, is properly qualified to submit a bid for this type of work in accordance with all applicable laws of the State of Alabama. Where applicable, this shall include evidence of holding a current license from the Alabama Licensing Board for General Contractors, Montgomery, Alabama, as required by Chapter 8, Title 34, of the Code of Alabama, 1975. In addition, the awarded vendor, if a non-resident of the State, and if a corporation, shall show evidence of having qualified with the Secretary of State to do business in the State of Alabama, <http://sos.alabama.gov/business-entities>. Awarded Bidder must have a current business license or purchase a business license with the City of Fairhope prior to work performed. No bids shall be withdrawn for the period of thirty (30) days after the opening of bids without the consent of the City of Fairhope, Baldwin County, Alabama. Once completed, a tabulation of the responsive and responsible bids will be available for public viewing by visiting the following web address: [www.fairhopeal.gov](http://www.fairhopeal.gov).

**Project: FD 4563-DR**  
**REPAIRS TO EXISTING BULKHEADS, PIERS & DOCKS**  
**DAMAGE DUE TO HC SALLY (DR-4563-AL)**  
**SCOPE OF WORK**

This work shall include furnishing all labor, equipment, materials and all incidentals necessary to rebuild, reinforce and/or repair City-owned bulkheads, piers and docks at the City's Marina on Fly Creek damaged by Hurricane Sally (DR-4563-AL) on September 16, 2020. Work includes but is not limited to: replacement/driving of wooden piles, bulkhead boards, whalers, repair and/or replacement of pile caps (beams), stringers, decking, railings, steps, fishing docks, covered piers and all other marina infrastructure at Fairhope Docks. Materials and workmanship shall be per the enclosed plans and specifications. Some work will involve field investigation and "design build" prior to repair. All proposed field modifications and "design builds" shall be reviewed and approved by the Public Works Director prior to Contractors initiation of work.

# FAIRHOPE DOCKS - DR-4563-AL

## BULKHEAD REPAIR PROJECT

### FLY CREEK - MOBILE BAY - CITY OF FAIRHOPE

APRIL 2021



**INDEX TO SHEETS**

<u>SHEET</u>	<u>DESCRIPTION</u>
1	Title
2	Overall Plan and Layout
3	Type "A" Bulkhead Repair @ Covered Slips
4	Type "B" Bulkhead Repair Plan
5	Type "C" Bulkhead Repair Plan & Details
6	Typical Bulkhead Repair Plan & details

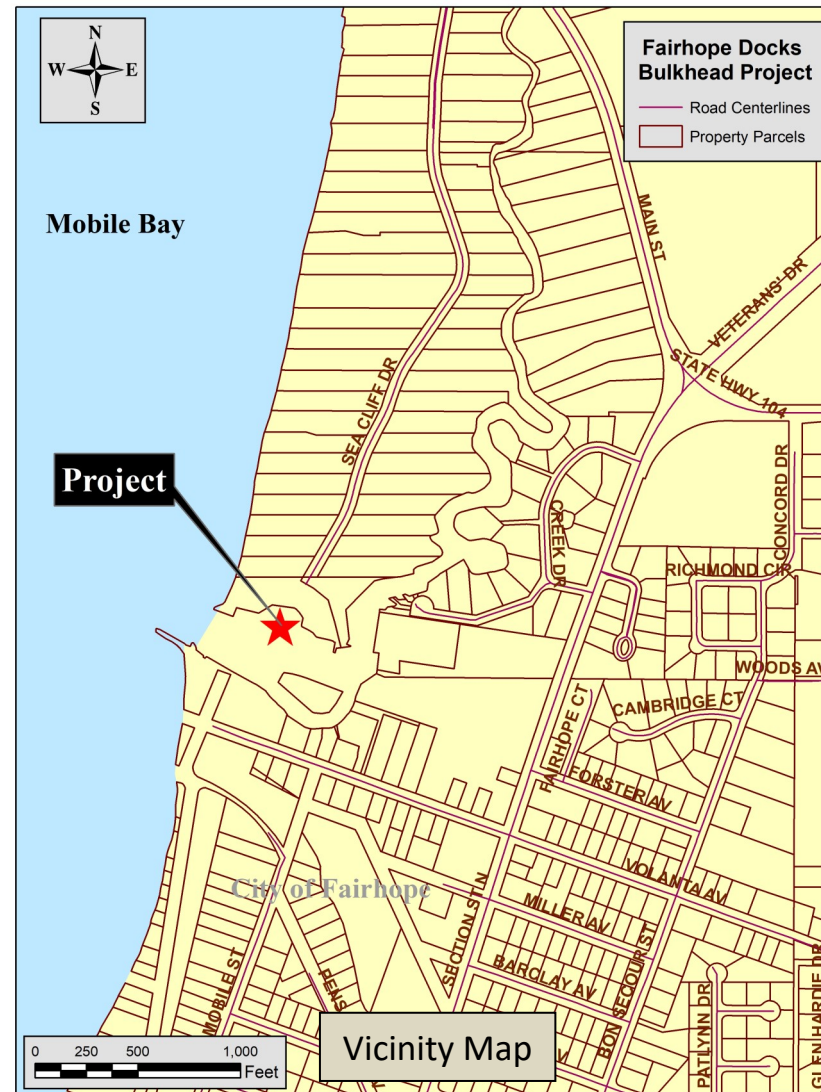

**MAYOR**

Sherry Sullivan

**CITY COUNCIL**

Kevin G. Boone

Corey Martin

Jack Burrell, ACOMO

Jimmy Conyers

Jay Robinson

**DIRECTOR OF PUBLIC WORKS**

Richard D. Johnson, PE

**CITY CLERK**

Lisa A. Hanks, MMC

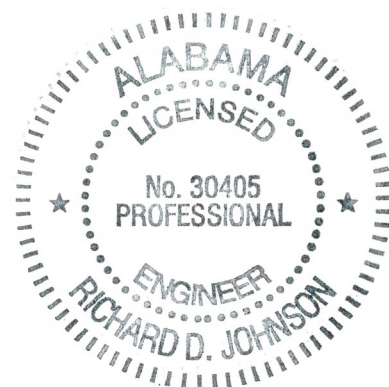

*Richard D. Johnson*

Richard D. Johnson  
AL. REG. NO. 30405  
Project Management

03-29-2021  
Date

**Project: FD 4365-DR  
Bid Set Drawings**

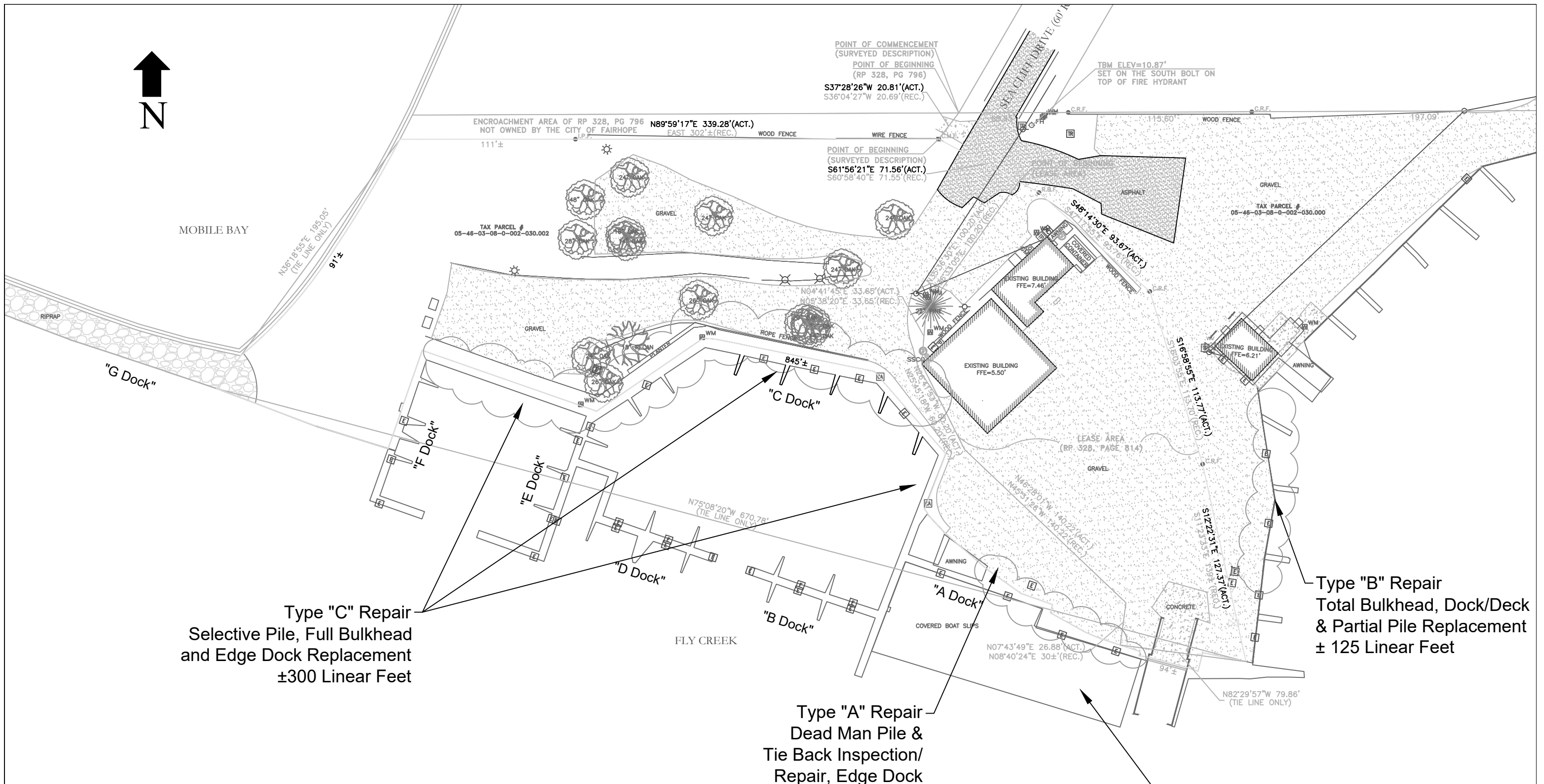

Type "C" Repair  
 Selective Pile, Full Bulkhead  
 and Edge Dock Replacement  
 ±300 Linear Feet

Type "A" Repair  
 Dead Man Pile &  
 Tie Back Inspection/  
 Repair, Edge Dock  
 Repair ± 125 Linear Feet

Type "B" Repair  
 Total Bulkhead, Dock/Deck  
 & Partial Pile Replacement  
 ± 125 Linear Feet

Covered Slips - See  
 Plan Detail

## FAIRHOPE DOCKS - BULKHEAD PA REPAIR PROJECT

Prepared By:	R.D. Johnson, PE	City of Fairhope
Date:	9/29/2020	Scale: 1" = 60'
Project No.:	FD 4365-DR	Sheet: 2 of 6

## FAIRHOPE DOCKS - BULKHEAD REPAIR HC SALLY - FEMA 4365-DR PLAN VIEW

# FAIRHOPE DOCKS - BULKHEAD PA REPAIR PROJECT

Prepared By:	R.D. Johnson, PE	City of Fairhope
Date: 9/30/2020	Repair A Details	Scale: N.T.S.
Project No.:	FD 4365-DR	Page: 3 of 6

## TYPE "A" REPAIR AT DOCK "A" COVERED DOCKS REPAIR DETAILS

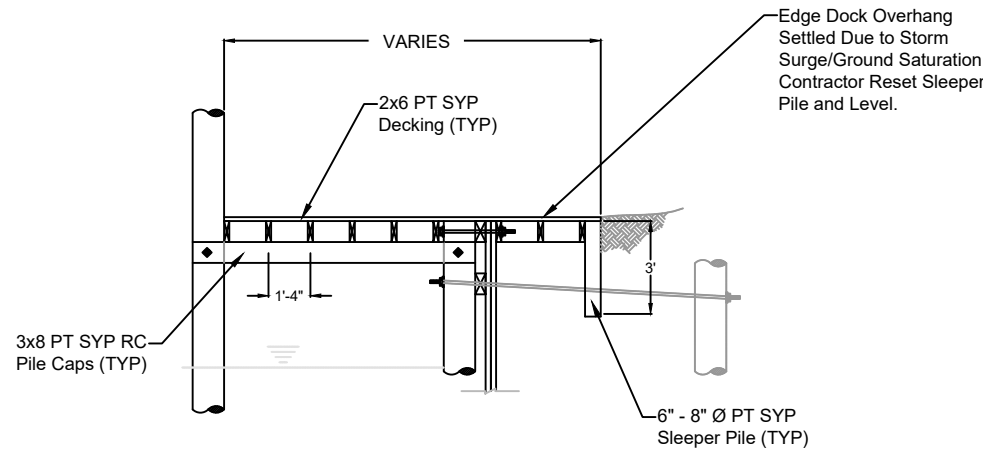

3  
03
TYPICAL EDGE DOCK AT  
COVERED BOAT SLIPS

### Type "A" Bulkhead Repair Notes:

1. The demolition, removal and disposal of all structures, docks, piers, piles, bulkheads and incidental materials shall be a subsidiary obligation of the unit price of the new construction.
2. All bulkhead boards, walers, top caps, etc. shall be replaced with new materials and hardware
3. Condition of bulkhead and deadman piles are unknown
4. Once piles are exposed they shall be evaluated for structural integrity. Piles to remain and piles to be replaced shall be by consensus of the Public Works Director, Marina Manager and Contractor.
5. Quantities are estimated on a 66% replacement rate.
6. Clean suitable backfill meeting the Red Soils Ordinance of the City of Fairhope shall be used behind repaired bulkhead. Fill material and proper compaction shall be a subsidiary obligation of the unit price of the new construction.
7. Surface material shall be 2" compacted of B -Base, R-Base, Slag or other clean material approved by the owner. Aggregate surfacing shall be a subsidiary obligation of the unit price of the new construction.

### GENERAL NOTES:

1. All wood shall be Pressure Treated (2.5 CCA), Southern Yellow Pine - Walers 4"x8" Rough Cut & Bulkhead boards 2"x8" Rough Cut.
2. Piling Penetration: Bulkhead Piles - a minimum of 20 feet below the finish elevation of the shown datum. Dead Man Piles - a minimum of 19 feet below the finish elevation of the shown datum.
3. All piles shall be mechanically driven - no jetting of piles. Pile trench may be excavated to waterline.
4. Dead Man Pile tops shall be cut off a minimum of 6" below finished grade. Backfill and grade to Elevation 0'-0".
5. Bulkhead Boards (2" rough cut dimensional) shall be fastened using #10 x 4-in Countersinking-Head Stainless Steel Screws - minimum 2 screws per connection point.
6. Bulkhead boards shall be driven to a minimum tip elevation of -16'-0" - preferably to pile tip depth of elevation -20'-0" or refusal depth, whichever comes first.
7. All through bolts or threaded rod fastening through piles shall be  $\frac{3}{4}$ " Ø hot dipped galvanized steal with  $2\frac{1}{2}$ " X  $2\frac{1}{2}$ " X  $\frac{1}{4}$ " hot dipped galvanized plate washers at each connection point.
8. Subsurface conditions are unknown. All "mucking out" or subsurface debris removal shall be a subsidiary obligation of the unit cost of the bulkhead retaining wall system.
9. All work proposed should match dimensions and geometric's of existing structure(s). Any areas of conflict should be addressed with the Director of Public Works prior to work.
10. All new and repair work shall be conducted and completed without damage to the existing pair structures and the existing pile bulkheads.
11. In Situ field conditions may require geometric adjustments of piles and bulkhead face lengths - contractor shall be allowed to make adjustments in the field with review and approval of the Director of Public Works.

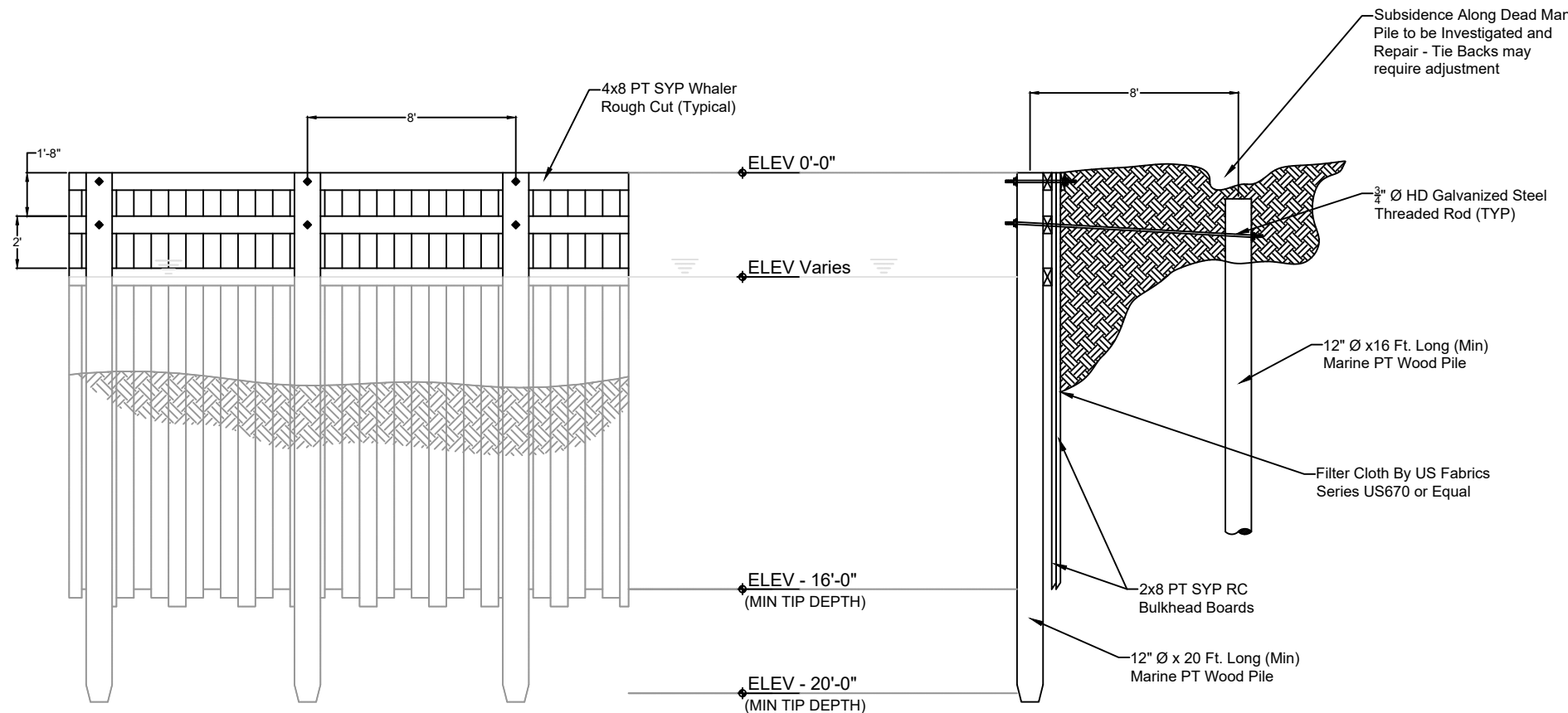

2  
03
TYPICAL BULKHEAD ELEVATION

1  
03
TYPICAL BULKHEAD CROSS SECTION

# FAIRHOPE DOCKS - BULKHEAD PA REPAIR PROJECT

Prepared By:	R.D. Johnson, PE	City of Fairhope
Date: 9/30/2020	Repair B Detail	Scale: N.T.S.
Project No.:	FD 4365-DR	Page: 4 of 6

## TYPE "B" BULKHEAD REPAIR PLAN VIEW

**GENERAL NOTES:**

1. All wood shall be Pressure Treated (2.5 CCA), Southern Yellow Pine - Whalers 4"x8" Rough Cut & Bulkhead boards 2"x8" Rough Cut.
2. Piling Penetration: Bulkhead Piles - a minimum of 20 feet below the finish elevation of the shown datum. Dead Man Piles - a minimum of 19 feet below the finish elevation of the shown datum.
3. All piles shall be mechanically driven - no jetting of piles. Pile trench may be excavated to waterline.
4. Dead Man Pile tops shall be cut off a minimum of 6" below finished grade. Backfill and grade to Elevation 0'-0".
5. Bulkhead Boards (2" rough cut dimensional) shall be fastened using #10 x 4-in Countersinking-Head Stainless Steel Screws - minimum 2 screws per connection point.
6. Bulkhead boards shall be driven to a minimum tip elevation of -16'-0" - preferably to pile tip depth of elevation -20'-0" or refusal depth, whichever comes first.
7. All through bolts or threaded rod fastening through piles shall be 3/4" Ø hot dipped galvanized steel with 2 1/2 X 2 1/2 X 1/4 hot dipped galvanized plate washers at each connection point.
8. Subsurface conditions are unknown. All "mucking out" or subsurface debris removal shall be a subsidiary obligation of the unit cost of the bulkhead retaining wall system.
9. All work proposed should match dimensions and geometric's of existing structure(s). Any areas of conflict should be addressed with the Director of Public Works prior to work.
10. All new and repair work shall be conducted and completed without damage to the existing pair structures and the existing pile bulkheads.
11. In Situ field conditions may require geometric adjustments of piles and bulkhead face lengths - contractor shall be allowed to make adjustments in the field with review and approval of the Director of Public Works.

**Type "B" Bulkhead Repair Notes:**

1. The demolition, removal and disposal of all structures, docks, piers, piles, bulkheads and incidental materials shall be a subsidiary obligation of the unit price of the new construction.
2. All bulkhead boards, whalers, top caps, etc. shall be replaced with new materials and hardware.
3. Condition of bulkhead and deadman piles are unknown.
4. Once piles are exposed they shall be evaluated for structural integrity. Piles to remain and piles to be replaced shall be by consensus of the Public Works Director, Marina Manager and Contractor.
5. Quantities are estimated on a 66% replacement rate.
6. Clean suitable backfill meeting the Red Soils Ordinance of the City of Fairhope shall be used behind repaired bulkhead. Fill material and proper compaction shall be a subsidiary obligation of the unit price of the new construction.
7. Surface material shall be 2" compacted of B-Base, R-Base, Slag or other clean material approved by the owner. Aggregate surfacing shall be a subsidiary obligation of the unit price of the new construction.

**Water and Electrical Notes:**

1. Contractor shall maintain existing water & electrical during construction with minimal interruption.
2. City shall coordinate with contractor to install new electrical conduit and junction boxes for future service.
3. City shall coordinate with contractor to install new water service conduit (valve off and/or capped) for future service.

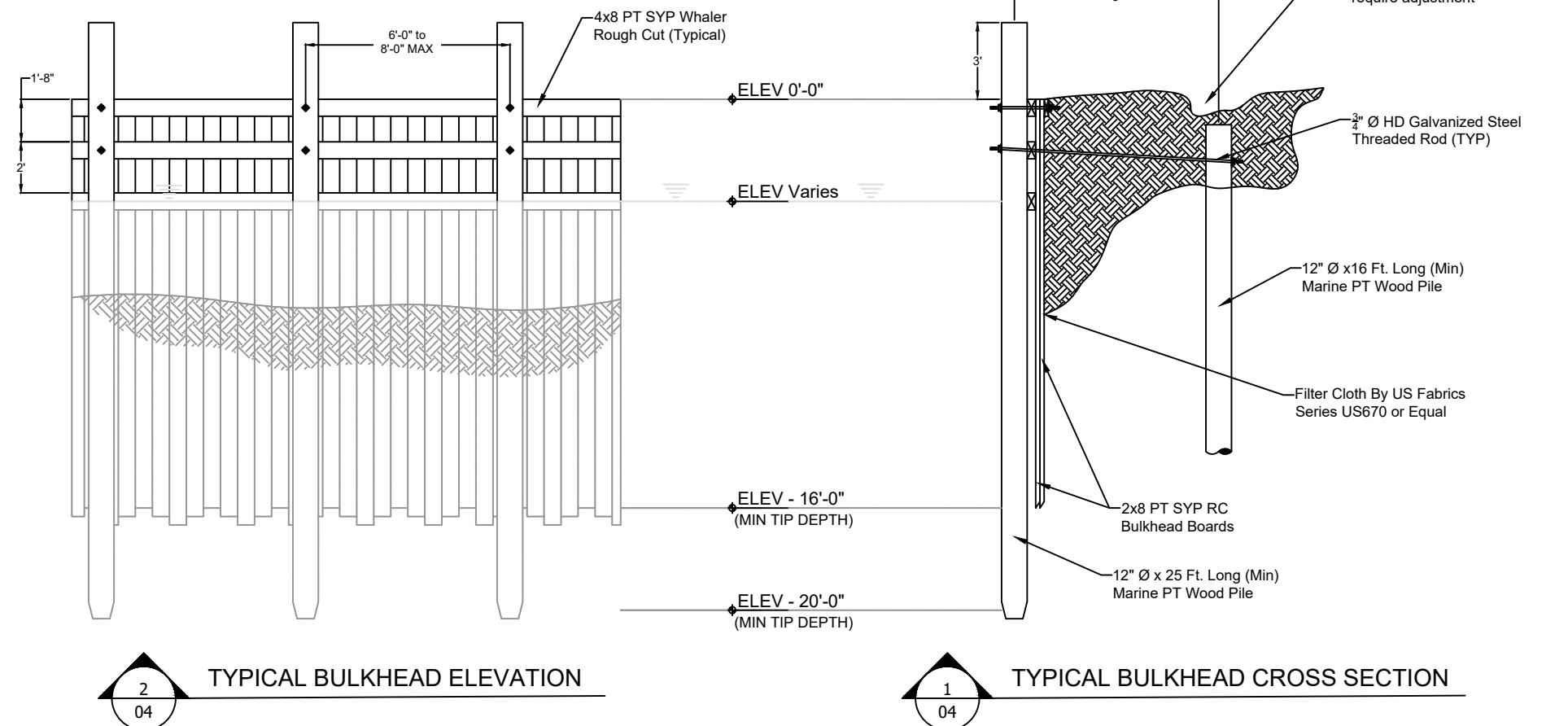
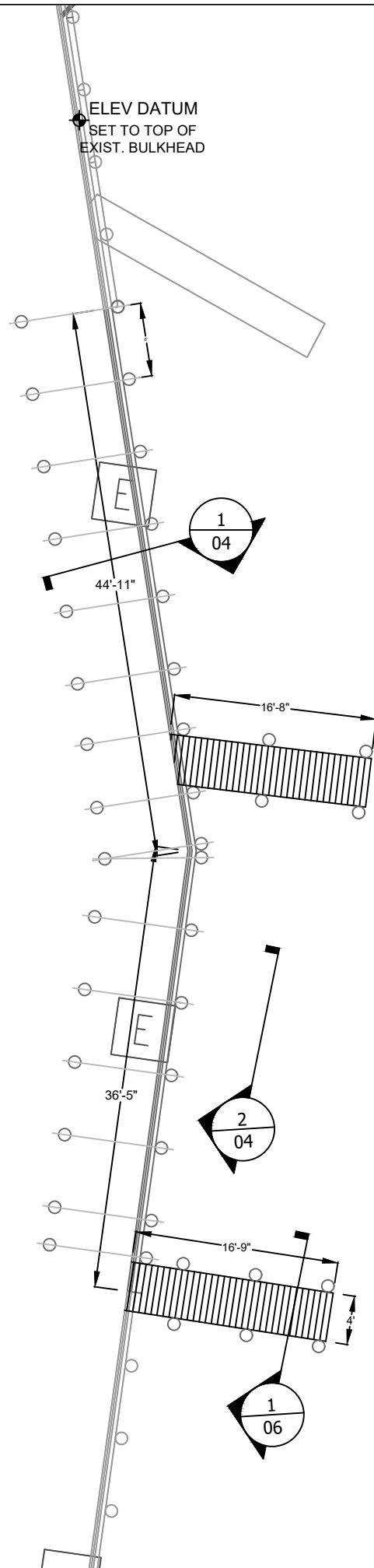

# FAIRHOPE DOCKS - BULKHEAD PA REPAIR PROJECT

Prepared By:	R.D. Johnson, PE	City of Fairhope
Date: 9/30/2020	Repair C Details	Scale: N.T.S.
Project No.:	FD 4365-DR	Page: 5 of 6

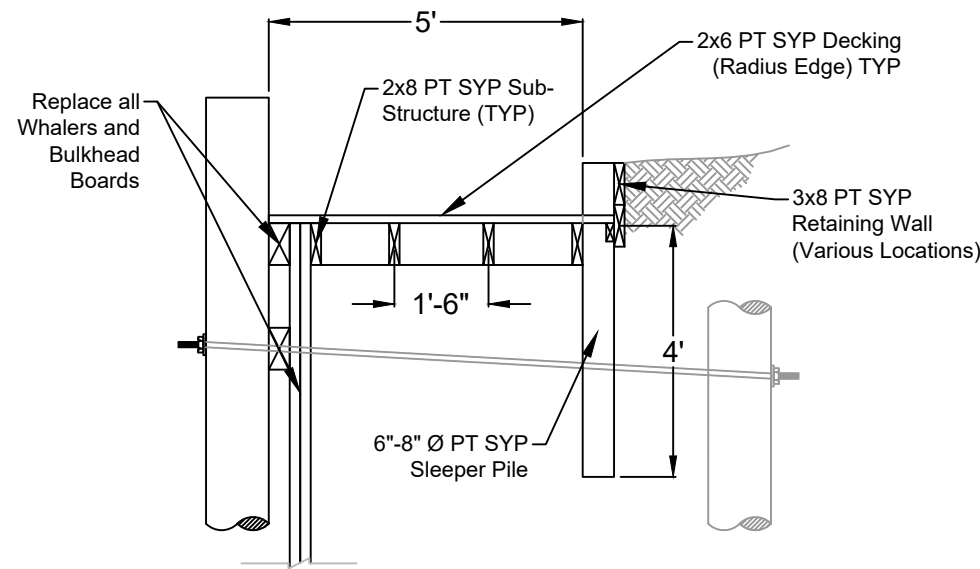

1  
05
**BULKHEAD EDGE DOCK  
CROSS SECTION**

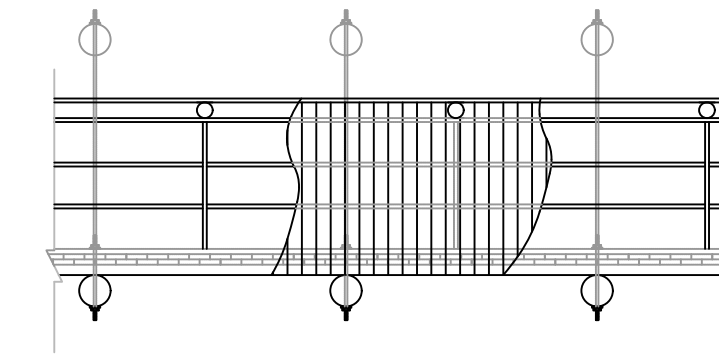

2  
05
**BULKHEAD EDGE DOCK  
PLAN VIEW**

**Type "C" Bulkhead Edge Dock Repair Notes:**

1. It is the intention of this repair to replace all damage to bulkhead (batter boards, whalers, top caps, edge docks and damage pilings) with new materials and hardware. Quantities assume 100% bulkhead and 66% pile replacement.
2. The demolition, removal and disposal of all structures, docks, piers, piles, bulkheads and incidental materials shall be a subsidiary obligation of the unit price of the new construction.
3. Approximately 300 L.F. of the Edge Dock to be replaced with new substructure and decking.
4. There is 1500 SF of Edge Dock - the unit price shall include demolition, removal, disposal, installation of new sleeper piles, substructure, retaining boards, 2x6 radius edge decking and all required hardware as a subsidiary obligation of the bid unit price.
5. Details are assumed typical. Once old edge dock and substructure is removed, contractor and engineer can finalize reconstruction details and design.

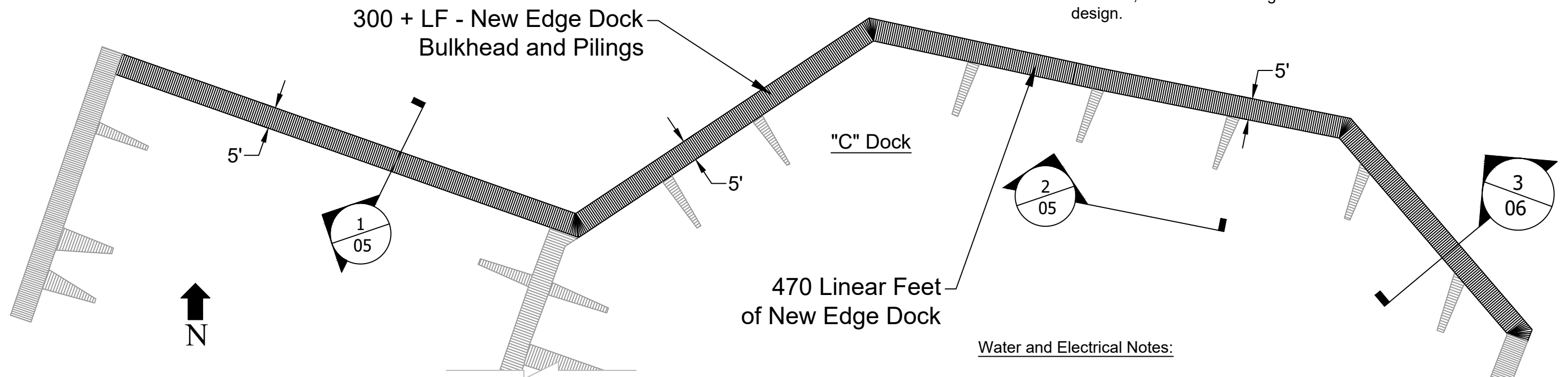

**TYPE "C" REPAIR  
EDGE DOCK & BULKHEAD AT INNER HARBOR  
PLAN VIEW**

**Water and Electrical Notes:**

1. Contractor shall maintain existing water & electrical during construction with minimal interruption.
2. City shall coordinate with contractor to install new electrical conduit and junction boxes for future service.
3. City shall coordinate with contractor to install new water service conduit (valve off and/or capped) for future service.



# FAIRHOPE DOCKS - BULKHEAD PA REPAIR PROJECT

Prepared By:	R.D. Johnson, PE	City of Fairhope
Date:	9/30/2020	General Details
Project No.:	FD 4365-DR	Scale: N.T.S.
		Page: 6 of 6

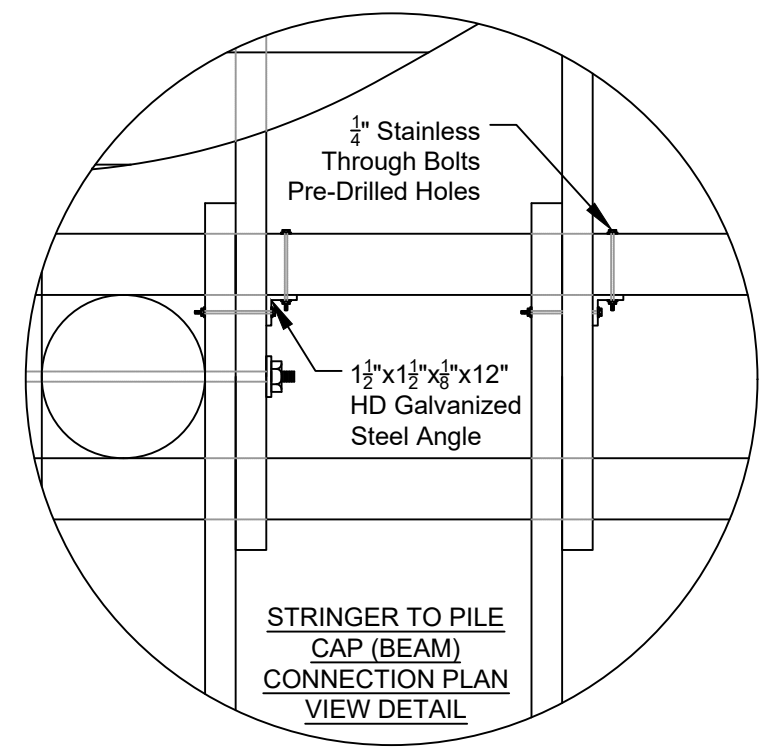
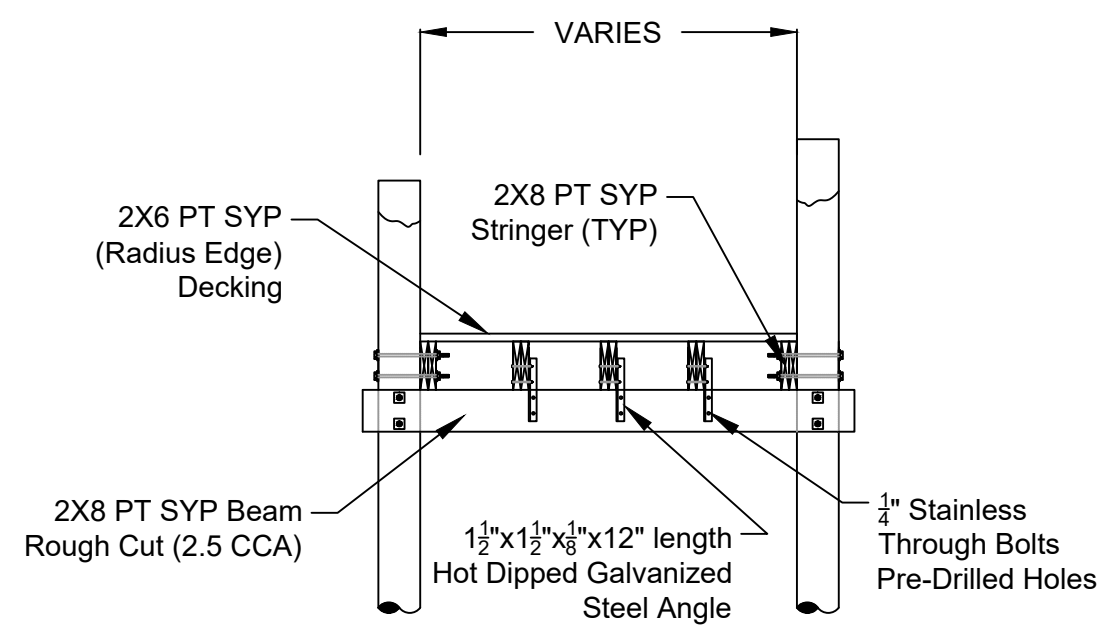

**1**  
 06  
**TYPICAL PIER CROSS SECTION**

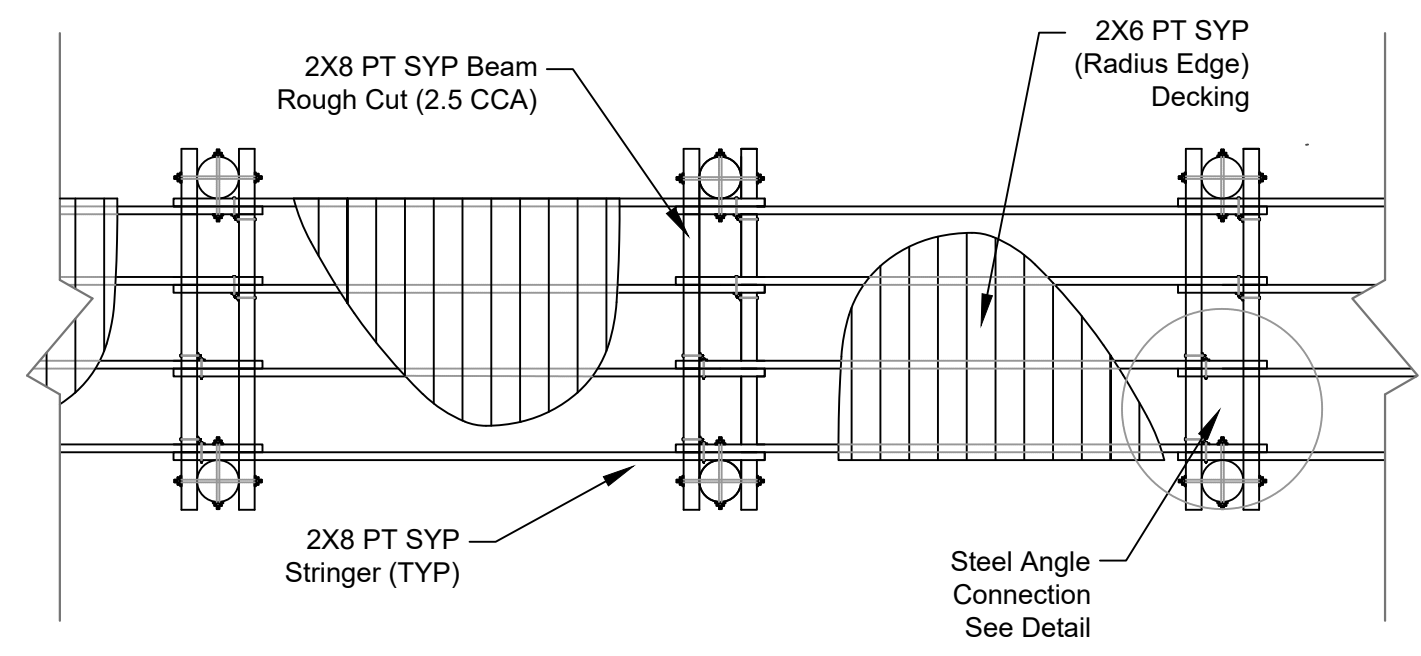

**2**  
 06  
**TYPICAL PIER PLAN VIEW**

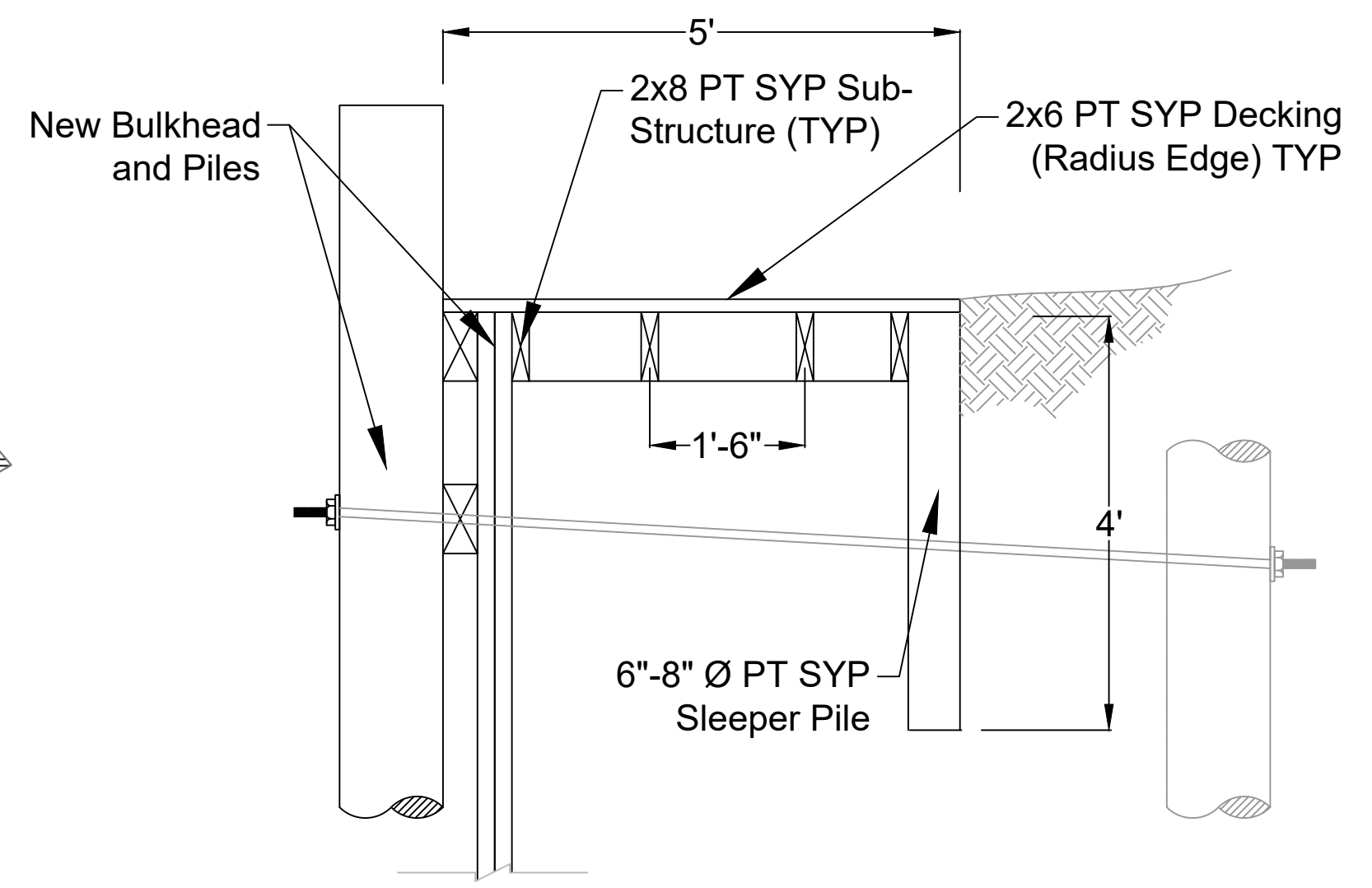

## **GENERAL CONDITIONS, SPECIAL PROVISIONS and SUPPLEMENTAL SPECIFICATIONS**

1. **SAFETY AND HEALTH REGULATIONS FOR CONSTRUCTION:** The Contractor shall comply with the Department of Labor Safety and Health Regulations for construction promulgated under the Occupational Safety and Health Act of 1970 (PL-596) and under Section 107 of the Contract Work Hours and Safety Standards Act (PL-91-54).

The contractor alone shall be responsible for the safety, efficiency, and adequacy of his plant, appliances, and methods, and for any damage which may result from their failure or their improper construction, maintenance, or operations.

2. **DEPARTMENT OF TRANSPORTATION SPECIFICATIONS:** It is the intent of the Public Works Director to construct the within described improvements, where applicable, in accordance with the State of Alabama Highway Department Standard Specifications for Highway Construction, most current edition. Said specifications shall be hereafter referred to as the Highway Department Specifications.

All provisions enumerated in the Highway Department Specifications shall be complied with, except as otherwise revised herein. Where certain modifications in said specifications appear in these specifications, only the modifications apply; otherwise, the standard specifications apply.

In said specifications where the words State of Alabama, Governor, State Highway Department, Director, etc., appear, substitute the Owner. Where the word Engineer appears, it shall mean Public Works Director. Where the words Testing Laboratory and/or Laboratory appear, it shall mean the particular Testing Laboratory retained by the Owner for this work.

3. **DEPARTMENT OF TRANSPORTATION DRAWINGS:** Where State of Alabama Department of Transportation Alabama Standard Drawings are applicable for the work required, they shall be considered as part of the plans, and copies of required drawings will be afforded the Contractor for construction purposes.
4. **PROJECT SITE:** The Contractor shall keep the project site clean at all times. No loose dirt, or stockpiles shall be left in areas other than those areas approved by the Public Works Director. The Public Works Director may require the Contractor to clean up any portion of the Project as he deems necessary. Construction & Demolition (C&D) must be cleaned up daily.
5. **MATERIALS:** The Contractor agrees to comply with, and to require the compliance of all subcontractors with the provisions of Act #876 of the Legislature of Alabama, adopted on September 8, 1961, requiring purchase of materials and supplies and products for the project which are manufactured, mined, processed, or otherwise produced in the United States or its territories if the same are available at reasonable prices; and the Contractor further agrees and stipulates to pay to the Owner a sum to be determined and fixed by the Owner in an amount not less than five hundred (\$500.00) dollars nor more than twenty (20%) percent of the gross amount of the Contract in the event he or any subcontractor breach this agreement to use domestic products.
6. **REPAIRS TO EXISTING BULKHEADS, PIERS & DOCKS:** This work shall include furnishing all labor, equipment, materials and all incidentals necessary to rebuild, reinforce and/or repair City-owned bulkheads, piers and docks at the City's Marina on Fly Creek damaged by Hurricane Sally (DR-4563-AL) on September 16, 2020. Work includes but is not limited to: replacement/driving of wooden piles, bulkhead boards, whalers, repair and/or replacement of pile caps (beams), stringers, decking, railings, steps, fishing docks, covered piers and all other marina infrastructure at Fairhope Docks. Materials and workmanship shall be per the enclosed plans and specifications. Some work will involve field investigation and "design build" prior to repair. All proposed field modifications and "design builds" shall be reviewed and approved by the Public Works Director prior to Contractors initiation of work.

## **GENERAL CONDITIONS, SPECIAL PROVISIONS and SUPPLEMENTAL SPECIFICATIONS**

7. **PUBLIC CONVENIENCE:** No attempt is made to restrict work hours of the Contractor's operations, but he is reminded that it will be necessary to arrange his work schedule to provide the least inconvenience to the public and individual residents. The Contractor shall take extra precaution to insure that traffic is protected by the use of, but not limited to, flashing signs and barrels. No direct payment will be made for any of the work described in this section.
8. **EROSION CONTROL:** Immediately prior to any clearing and grubbing or any excavation which could disturb the soils, the Contractor shall install the erosion control items in locations as required by the nature of the work performed. The provide Erosion Control Plan shall be considered the minimum requirement for the project.

The Contractor will be responsible for identifying and installing erosion control in areas where erosion may be encountered during construction of the project. The Contractor shall take all necessary precautions to insure that the construction of the project and the erosion/sediment from the project are adequately controlled and do not damage streams or adjacent property.

The erosion control items installed shall be maintained by the Contractor throughout the course of the project. The City of Fairhope's Environmental Programs Manager shall be the final authority for corrective action, remediation, requirement of additional BMP's and all other directives required for erosion/sediment control.

9. **UNDERGROUND UTILITIES AND SERVICES:** Existing utilities, mailboxes, signs and minor obstructions are not shown on the plans. Their presence, and the required removal and the resetting thereof shall be considered incidental to the overall project and the cost for the work noted above shall be included in the overall "lump sum" price for the project (no separate payment).

The Contractor is solely responsible for the locating all existing Utilities and Services. Failure of the Contractor to locate any utility does not justify additional payment to the Contractor if said utility is damaged. The Contractor must notify the utility companies involved prior to starting construction and shall make every effort not to damage any utilities. If utilities are damaged by the Contractor, the Contractor must pay all expenses incurred in the repair at no cost to the Owner or his representatives.

10. **PROVISIONS REQUIRED BY LAW DEEMED INSERTED:** Each and every provision of law and clause required by law to be inserted in this contract shall be deemed to be inserted herein and the contract shall be read and enforced as though it were included herein, and if through mistake or otherwise any such provision is not inserted, or is not correctly inserted, then upon the application of either party the contract shall forthwith be physically amended to make such insertion or correction.
11. **PROTECTION OF LIVES AND HEALTH:** "The Contractor shall exercise proper precaution at all times for the protection of persons and property and shall be responsible for all damages to persons or property, either on or off the site, which occur as a result of his prosecution of the work. The safety provisions of applicable laws and building and construction codes, in addition to specific safety and health regulations described by Chapter XIII, Bureau of Labor Standards, Department of Labor, Part 1518, Safety and Health Regulations for Construction, as outlined in the Federal Register, Volume 36, No. 75, Saturday, April 17, 1971. Title 29 - LABOR, shall be observed and the Contractor shall take or cause to be taken, such additional safety and health measures as the Contracting Authority may determine to be reasonably necessary."
12. **PUBLIC WORKS DIRECTOR'S AUTHORITY:** The Public Works Director shall give all orders and directions contemplated under this contract and specifications, relative to the execution of the

## **GENERAL CONDITIONS, SPECIAL PROVISIONS and SUPPLEMENTAL SPECIFICATIONS**

work. The Public Works Director shall determine the amount, quality, acceptability, and fitness of the several kinds of work and materials which are to be paid for under this contract and shall decide all questions which may arise in relation to said work and the construction thereof. The Public Works Director's estimates and decisions shall be final and conclusive, except as herein otherwise expressly provided. In case any question shall arise between the parties hereto relative to said contract or specifications, the determination or decision of the Public Works Director's shall be a condition precedent to the right of the Contractor to receive any money or payment for work under this contract affected in any manner or to any extent by such question.

The Public Works Director shall decide the meaning and intent of any portion of the specifications and of any plans or drawings where the same may be found obscure or be in dispute. Any differences or conflicts in regard to their work which may arise between the Contractor under this contract and other Contractors performing work for the Owner shall be adjusted and determined by the Public Works Director.

13. **USE OF PREMISES AND REMOVAL OF DEBRIS:** The Contractor expressly undertakes at his own expense:
  - a. to take every precaution against injuries to persons or damage to property;
  - b. to store his apparatus, materials, supplies and equipment in such orderly fashion at the site of the work as will not unduly interfere with the progress of his work or the work of any other contractors;
  - c. to place upon the work or any part thereof only such loads as are consistent with the safety of that portion of the work; materials, and debris caused by his operations, to the end that at all times the site of the work shall present a neat, orderly and workmanlike appearance;
  - d. before final payment to remove all surplus material, false-work, temporary structures, including foundations thereof, plant of any description and debris of every nature resulting from his operations, and to put the site in a neat, orderly condition;
  - e. to affect all cutting, fitting or patching of his work required to make the same to conform to the plans and specifications and, except with the consent of the Public Works Director, not to cut or otherwise alter the work of any other Contractor.
  - f. The removal and proper disposal of all construction and demolition (C&D) debris is the contractor's responsibility. The cost of such removal and disposal shall be a subsidiary obligation of the related works unit costs.
  
14. **INSURANCE:** The Contractor shall not commence work under this contract until he has obtained all the insurance required under the terms of this contract.
  
15. **STATE OF ALABAMA GENERAL CONTRACTOR LICENSE:** Any proposed bidder for this project must possess and maintain a valid Alabama General Contractor (GC) License to qualify to submit bids in the state of Alabama (Code of Alabama; Section 34-8-8). The license must be maintained and valid throughout the contract period. The prime contractor may receive bids from unlicensed subcontractors; however the subcontractor must be licensed before beginning work (Code of Alabama; Section 34-8-7). A copy of all GC Licenses must be provided by the Pre-Construction Conference.
  
16. **CITY OF FAIRHOPE BUSINESS LICENSE:** The Contractor shall not commence work under this contract until he has obtained a City of Fairhope Business License. The license must be maintained and valid throughout the contract period. A copy of the Business License must be provided by the Pre-Construction Conference.
  
17. **MATERIALS, SERVICES AND FACILITIES:**
  - a. It is understood that except as otherwise specifically stated in the Contract Documents, the Contractor shall provide and pay for all materials, labor, tools, equipment, water, light,

## **GENERAL CONDITIONS, SPECIAL PROVISIONS and SUPPLEMENTAL SPECIFICATIONS**

power, transportation, supervision, temporary construction of every nature, and all other services and facilities of every nature whatsoever necessary to execute, complete and deliver the work within the specified time.

- b. Any work necessary to be performed after regular working hours, on Sundays or Legal Holidays, shall be performed without additional expense to the Owner.

18. **CONTRACTOR'S TITLE TO MATERIALS:** No materials or supplies for the work shall be purchased by the Contractor or by any Subcontractor subject to any chattel mortgage or under a conditional sale contract or other agreement by which an interest is retained by the seller. The Contractor warrants that he has good title to all materials and supplies used by him in the work, free from all liens, claims or encumbrances.

19. **INSPECTION AND TESTING OF MATERIALS:**

- a. All materials and equipment used in the construction of the project shall be subject to adequate inspection and testing in accordance with accepted standards. The laboratory or inspection agency shall be selected by the Owner. The Owner will pay for all laboratory inspection service direct, and not as a part of the contract.
- b. Materials of construction, particularly those upon which the strength and durability of the structure may depend, shall be subject to inspection and testing to establish conformance with specification and suitability for uses intended.

20. **QUANTITIES AND PAYMENTS:** Quantities provided are best estimates and may vary with field conditions. Contractor should field verify prior to bidding. Payment will be made on actual measured quantities of work/materials performed. Mobilization/demobilization shall be quantified and separately paid. All required demolition, removal, transport and disposal of existing infrastructure shall be a subsidiary obligation of the quoted unit prices in the aggregate. Only three-monthly pay requests will be entertained: monthly payment and at substantial completion. Release of retainage will occur after final acceptance and complete project closeout (30 days post advertisement). A 5% of 50% of the project total retainage will be applied to the project.

21. **CONTRACT TIME:** Contract time for this project shall be one hundred & twenty (120) Calendar days from the Notice to Proceed date.

22. **MATERIAL SPECIFICATIONS:**

- a. Piles:
  - i. Minimum Diameter (Large end of taper 12", small end of taper 8")
  - ii. Pressure Treated 2.5 pcf CCA
  - iii. Piling Penetration Shall be the Greater of: 10' Penetration into ground or 2/3 total length of pile. Contractor is to Determine the Length of Piling Needed To Meet This Requirement.
  - iv. For new piles with exposed tops - Top of Piling Shall Be Sanded Smooth and Edges Rounded 1/4"
- b. Dimensional Lumber:
  - i. No. 1, Pressure Treated (2.5 pcf CCA), Southern Yellow Pine
  - ii. Deck Boards and Rail Caps shall be No. 1, Pressure Treated (2.5 pcf CCA), Southern Yellow Pine with Radius Edge
- c. Rough Cut Lumber (Pile Caps (Beams)
  - i. No. 1, Pressure Treated (2.5 pcf CCA), Southern Yellow Pine
- d. Bulkhead Boards and Whalers - All wood shall be Pressure Treated (2.5 CCA), Southern Yellow Pine
  - i. Whalers 4"x8" Rough Cut
  - ii. Bulkhead boards 2"x8" Rough Cut
- e. Fasteners & Hardware:

## **GENERAL CONDITIONS, SPECIAL PROVISIONS and SUPPLEMENTAL SPECIFICATIONS**

- i. Deck Screws - #10 x 3.5-in Countersinking-Head Stainless Steel (Type 304 or 316) Deck Screws - minimum 2 screws per stringer and/or connection point.
- ii. Through Bolts (fastening pile caps (beams) and stringers to piles) - 5/8" Ø hot dipped galvanized steel with 2 1/2 X 2 1/2 X 1/4 hot dipped galvanized plate washers.
- iii. Stringer to Pile Cap (Beam) Fastener - 1 1/2" X 1 1/2" X 1/8" X 12" length Hot Dipped Galvanized Steel Angle with 1/4" Ø Stainless Through Bolts into Pre-Drilled Holes.
- iv. Bulkhead Boards (2" rough cut dimensional) shall be fastened using #10 x 4-in Countersinking-Head Stainless Steel Screws - minimum 2 screws per connection point.
- v. Whalers to Bulkhead Boards - 1/4" x 8" Strong-Tie SDS Heavy-Duty Connector Screw - Double-Barrier Coating – one per connection point
- vi. Nails – No nails shall be used for final mechanical connection. Nails may be used for temporary shoring and setting of structure. Any nails used must be compliant for use with treated wood in a saltwater/air environment.

23. **FAILURE TO COMPLETE WORK WITHIN CONTRACT TIME:** Should the Contractor, or in case of default, the surety, fail to complete the work within the time stipulated in the contract or the adjusted time as granted under the provisions of this contract, a deduction for each calendar day that any work shall remain uncompleted, an amount of **\$250.00 (two-hundred and fifty and no/100)** shall be deducted from any monies due the Contractor on monthly estimates. Any adjustments due to approved time extensions or overruns in the contract amount will be made on the monthly, semi-final or final estimate as may be appropriate. Liquidated damages assessed as provided in these Specifications is not a penalty, but is intended to compensate the City for increased time in administering the contract, supervision, inspection and management, particularly that management and inspection which requires maintaining normal field project management forces for a longer time on any construction operation or phase than originally contemplated when the contract period was agreed upon in the contract. Permitting the Contractor to continue and finish the work or any part of it after the time fixed for its completion, or after the date to which the time for completion may have been extended, will in no way operate as a waiver on the part of the City of any of its rights under the contract.

## SECTION 2

### GENERAL DEFINITIONS

Where hereinafter used in these PROJECT SPECIFICATIONS the following definitions shall apply:

2-01 Owner. The term "Owner" or "City" shall refer to:  
CITY OF FAIRHOPE  
FAIRHOPE, ALABAMA

2-02 Bidder. The term "Bidder" shall refer to the person, partnership, firm or corporation submitting a Proposal to Contract with the Owner for the work put forth in these PROJECT SPECIFICATIONS.

2-03 Contractor. The term "Contractor" shall refer to the successful Bidder, the person, partnership, firm or corporation contracting with the Owner to perform and complete the work put forth in these PROJECT SPECIFICATIONS.

2-04 Project. The term "Project" shall refer to the work put forth in these PROJECT SPECIFICATIONS.

2-05 Approved. The term "Approved" shall refer to the City's approval, in writing, or by his duly authorized delegate or representative thereunto authorized by the City, in writing.

2-06 Completion Of Construction: The term "Completion of Construction" shall refer to the full performance by the Contractor of the Contractor's obligations under the Contract and all amendments and revisions thereof except the Contractor's obligations in respect to Release of Liens and Certificate of Contractor under Section 4 Paragraph 33 and 34 of these PROJECT SPECIFICATIONS.

2-07 Completion Of The Project. The term "Completion of the Project" shall refer to the full performance by the Contractor of the Contractor's obligations under the Contract and all amendments and revisions thereof.

2-08 Certificate Of Completion. The term "Certificate of Completion" shall refer to a written certificate signed by the City and approved, in writing, by the Owner and shall be the sole and conclusive evidence as to the date of Completion of Construction and as to the fact of Completion of the Project.

## SECTION 3

### NOTICE AND INSTRUCTIONS TO BIDDERS

3-01 Sealed Proposals for performing construction prescribed in the Fairhope Docks Bulkhead Repairs - FEMA 4563 will be received by the Owner on or before December 15, 2020, at 10:00, Local Time in the City of Fairhope Public Utilities Office, at 555 South Section Street, Fairhope, Alabama 36532, at which time and place the proposals will be publicly opened and read. Any Proposal received subsequent to the time specified will not be considered and will be promptly returned to the Bidder unopened.

3-02 Description of Projects. The Project will consist of supplying and paying for all labor, equipment, tools, transportation, supervision and other means to perform the work put forth in these PROJECT

SPECIFICATIONS. The project is generally described as: **Fairhope Docks Bulkhead Repairs - FEMA 4563**

The Project is located in Baldwin County, in the State of Alabama, all as more fully described in these PROJECT SPECIFICATIONS.

3-03 Obtaining and Transferring PROJECT SPECIFICATIONS. The PROJECT SPECIFICATIONS together with all necessary documents for bidders may be obtained, for the purpose of compiling bids only, from the City of Fairhope, 555 South Section Street, Fairhope, AL 36532.

The Bidder may, during the bidding period, be advised by bulletins (which term includes addenda to the specifications) of additions, deletions, or alterations in any of the documents forming a part of this Contract. All such changes shall be included in the work covered by the bid and shall become a part of this contract. The Bidder shall state in his bid the number and title of all bulletins which he has received.

3-04 Familiarity with Conditions. Prior to the submission of the Proposal the Bidder shall make and shall be deemed to have made a careful examination of the site of the Project and of the PROJECT SPECIFICATIONS, and forms of Contractor's Proposal and Contractor's Bond on file with the Owner, and shall become informed as to the location and nature of the proposed construction, the transportation facilities, the kind and character of soil and terrain to be encountered, the kind of facilities required before and during the construction of the Project, general local conditions and all other matters that may affect the cost and the time of completion of the Project.

3-05 Work on Energized Lines. Not applicable.

3-06 Owner Furnished Materials. See Construction Notes on Drawing E1.

3-07 The Owner Represents. All funds necessary for prompt payment for construction of the Project will be available.

3-08 Bidder's Qualifications. A Bidder who has not already completed similar electrical construction contracts shall file with the City the Bidder's Qualifications, on forms supplied by the City, at least ten (10) days in advance of the scheduled bid opening. No Bidder's Qualifications form will be required of a prospective Bidder who, to the knowledge of the Owner, has already completed such work, unless, prior to the issuance by the Owner or City to such Bidder of a set of PROJECT SPECIFICATIONS bearing a serial number, the City shall in writing notify such Bidder to submit the Bidder's Qualifications. A bid will not be considered from a Bidder required to submit Bidder's Qualifications who has not been notified by the City prior to the bid opening that such Bidder's Qualifications are satisfactory to the Owner. Questions, if any, concerning the sufficiency of such prior work performed by a prospective Bidder or the necessity for filing Bidder's Qualifications forms shall be raised by the Bidder at least ten (10) days prior to the time herein specified for filing the Bidder's Qualifications; questions relating to completed Bidder's Qualifications forms shall be resolved prior to the scheduled bid opening.

3-09 Alternate Designs. Not applicable.

3-10 Bidder's Experience. In estimating the least cost to the Owner as one of the factors in deciding the acceptance of the Proposal, the Owner will consider, in addition to the bid prices of the construction, the experience and responsibility of the Bidder.

3-11 The Time for Completion of Construction of the Project shall be as specified by the City in Section 4 Paragraph 7a.

3-12 Minor Irregularities. The Owner reserves the right to waive minor irregularities or minor errors in any Proposal, if it appears to the Owner that such irregularities or errors were made through inadvertence. Any such irregularities or errors so waived must be corrected on the Proposal in which they occur prior to the acceptance thereof by the Owner.

3-13 Manner of Submitting Proposals. Proposal and all supporting instruments must be submitted on the forms furnished by the City and must be delivered in a sealed envelope addressed to the Owner. The name and address of the Bidder, its License Number if a License Number is required by the State, and the date and hour of the opening of bids must appear on the envelope in which the Proposal is submitted. Proposals must be filled in with ink or typewritten. No alterations or interlineations will be permitted, unless made before submission, and initialed and dated.

3-14 Bid Bond. Each Proposal must be accompanied by a Bid Bond in the form attached or a Certified Check



on a Bank that is a member of the Federal Deposit Insurance Corporation, payable to the order of the Owner, in an amount equal to ten percent (10%) of the maximum bid price, but not to exceed \$10,000.00. Each Bidder agrees, provided its Proposal is one of the three low Proposals, that by filing its Proposal together with such Bid Bond or Check in consideration of the Owner's receiving and considering such Proposal, said Proposal shall be firm and binding upon each such Bidder, and such Bid Bond or Check shall be held by the Owner until a Proposal is accepted and a satisfactory Contractor's Bond is furnished by the successful Bidder, or for a period not to exceed sixty (60) days from the date herein before set for the opening of Proposals, whichever period shall be the shorter. If such Proposal is not one of the three low Proposals the Bid Bond or Check will be returned in each instance within a period of ten (10) days to the Bidder furnishing same.

3-15 Contractor's Bond. The successful Bidder will be required to execute two additional counterparts of the Proposal and to furnish a Contractor's Bond in triplicate in the form attached hereto with sureties listed by the United States Treasury Department as Acceptable Sureties, in a penal sum not less than the contract price.

3-16 Failure to Furnish Contractor's Bond. Should the successful Bidder fail or refuse to execute such counterparts or to furnish a Contractor's Bond within ten (10) days after written notification of the acceptance of the Proposal by the Owner, the Bidder will be considered to have abandoned the Proposal. In such event, the Owner shall be entitled (a) to enforce the Bid Bond in accordance with its terms, or (b) if a Certified Check has been delivered with the Proposal, to retain from the proceeds of the Certified Check the difference (not exceeding the amount of the Certified Check) between the amount of the Proposal and such larger amount for which the Owner may in good faith contract with another party to construct the Project. The term "successful Bidder" shall be deemed to include any Bidder whose Proposal is accepted after another Bidder has previously refused or has been unable to execute the counterparts or to furnish a satisfactory Contractor's Bond.

3-17 Owner's Right to Reject Bids. The Owner reserves the right to reject any and all bids when such rejection is in the interest of the Owner; to reject the bid of a Bidder who has previously failed to perform properly or complete on time jobs of a similar nature; and to reject the bid of a Bidder who is not, in the opinion of the Owner, in a position to perform the Contract.

3-18 Contract is Entire Agreement. The Contract to be affected by the acceptance of the Proposal shall be deemed to include the entire agreement between the parties thereto, and the Bidder shall not claim any modification thereof resulting from any representation or promise made at any time by any officer, agent or employee of the Owner or by any other person.

3-19 Awarding the Contract. The Owner will make the award as soon as practicable to the lowest responsible Bidder, price and other factors considered, provided it is reasonable, and it is to the best interest of the Owner.

Whenever applicable, equalizing elements or factors whether or not specifically mentioned or provided therein, such as transportation or inspection costs or any other element or factor in addition to that of price which would affect the total cost to the Owner will be taken into consideration in comparing bids for award of the Contract.

Should the Owner, for legal reasons, be unable to execute a binding Contract with the successful Bidder within sixty (60) days from date set for bid opening, the Bidder may withdraw his bid. Bids may be withdrawn on written or telegraphic request received from Bidders prior to the time fixed for opening.

## SECTION 4

## Supplemental GENERAL CLAUSES

4-01 General Conditions. The contract includes the accepted Proposal and the PROJECT SPECIFICATIONS, of which the Proposal is a part. Two or more copies of the Contract shall be signed by both parties and one signed copy retained by each party.

The intent of these documents is to include all material, labor and services of every kind necessary for the proper execution of the work and the terms and conditions of payment thereof.

The documents are to be considered as one and whatever is called for by any one of the documents shall be as binding as if called for by all.

This Contract and the drawings and specifications referred to herein contemplate a finished piece of work of such character and quality as is described in these PROJECT SPECIFICATIONS and is reasonably inferable from them. The Contractor, recognizing the impossibility of producing drawings and specifications with perfect accuracy, agrees that this submitted price for the work hereunder includes sufficient money allowance to make his work complete and operable to fit in with the work of any subcontractors, and the Owner and in compliance with good practice and the ordinances, codes, and regulations of all bodies or persons having Governmental authority over it. The Contractor agrees that inadvertent discrepancies or omissions, or the failure to show details or to repeat on any drawings the figures or notes given on another shall not be the cause for additional charges or claims.

The Owner retains the right to let other contracts in connection with the Project and the Contractor shall properly cooperate with any such other contractors.

4-02 Material and Equipment Schedule. All material for installation on this project will be supplied by Contractor, except as noted in Section 3-06.

4-03 Checking Contractor's Drawings. Unless otherwise specified, not less than three (3) copies of all Contractor's drawings shall be submitted to the City at the proper time so as to prevent delays in delivery of materials. The drawings shall be submitted in the order in which materials are needed at the site without necessarily waiting for completion of all drawings before submitting part of them for approval.

4-04 Owner-Furnished Materials. See Section 3-06.

4-05 Approval of Alternate Materials. The City may approve materials, construction and equipment other than those named or described if he believes that they are in accordance with the Construction Specifications and are desirable, but no such approval shall be valid unless in writing. Alternate proposals or requests for approval, fully describing the work or materials and stating any difference in price will be given consideration, but without any obligations, expressed or implied on the part of the

City to change the named requirements of the Construction Specifications. All requests for approval, including those for material or work not definitely specified or shown on the drawings or called for in the Construction Specifications, shall be made in writing to the City.

4-06 Right-Of-Way Clearing. None required.

4-07 Time and Manner of Construction.

- a. The Contractor agrees to commence construction of the Project on a date (hereinafter called the "Commencement Date") which shall be determined by the City after notice to the Contractor, in writing, of acceptance of the Proposal by the Owner and notice, in writing, from the Owner that sufficient materials to warrant commencement and continuation of construction, but in no event will the Commencement Date be later than fifteen (15) calendar days after the date of executed contract by the Owner. The Contractor further agrees to prosecute diligently and to complete construction in strict accordance with the PROJECT SPECIFICATIONS within 30 days. Provided however, that the Contractor will not be required to perform any construction on such days when, in the judgment of the City, snow, rain or wind, or the results of snow, rain or frost make it impracticable to perform any operation of construction. To the extent of the time lost due to the conditions described herein and approved in writing by the City, the time of completion set out above will be extended if the Contractor makes a written request therefore to the Owner as provided in Subsection "b" of this Paragraph.
- b. Liquidated Damages: Time is the essence of the Contract. Any delay in the completion of the Work as provided for in the Contract Documents will cause inconvenience to the public and loss and damage to the Owner in interest, and in additional administrative, inspection and supervision charges.

Therefore, a time charge equal to TWO HUNDRED FIFTY DOLLARS (**\$250.00**) per day will be made against the Contractor for the entire period that any part of the Work remains uncompleted after the time specified THIRTY (30) days for the completion of the Work as provided in the Contract Documents, the amount of which shall be deducted by the Owner from the Final Estimate, and shall be retained by the Owner out of money's otherwise due the Contractor in the Final Payment, not as a penalty, but as liquidated damages sustained, it being mutually understood and agreed between the parties hereto that such amount is reasonable as liquidated damages.

- c. The time for Completion of Construction shall be extended for the period of any reasonable delay which is due exclusively to causes beyond the control and without the fault of the Contractor, including Acts of God, fires, floods, and acts or omissions of the Owner with respect to matters for which the

Owner is solely responsible. Provided, however, that no such extension of time for completion shall be granted the Contractor unless within ten (10) days after the happening of any event relied upon by the Contractor for such an extension of time the Contractor shall have made a request therefor in writing to the Owner, and provided further that no delay in such time of completion or in the progress of the work which results from any of the above causes except acts or omissions of the Owner, shall result in any liability on the part of the Owner.

- d. The sequence of construction shall be as set forth below, the numbers or names being the designations of extensions or areas (hereinafter called the "Segments") corresponding to the numbers or names shown on the maps attached hereto, or if no Segments are set forth below, the sequence of construction shall be as determined by the Contractor, subject to the approval of the City.
- e. The Owner, acting through the City, may from time to time during the progress of the construction of the Project make such changes, additions to or subtractions from the Construction Specifications and Drawings, Materials and/or sequence of construction provided for in the previous paragraph as conditions may warrant. Provided however, that if any change in the construction to be done shall require an extension of time, a reasonable extension will be granted if the Contractor shall make a written request therefore to the Owner within ten (10) days after any such change is made. And provided further, that if the cost to the Contractor of construction of the project shall be materially increased by any such change or addition, the Owner shall pay the Contractor for the reasonable cost thereof in accordance with a Construction Contract Amendment signed by the Owner and the Contractor, but no claims for additional compensation for any such change or addition will be considered unless the Contractor shall have made a written request therefore to the Owner prior to the commencement of work in connection with such change or addition.
- f. The Contractor will not perform any work hereunder on Sundays without the Owner's approval. The time for completion specified in subsection "a" of this Paragraph shall not be affected in any way by inclusion of this subsection nor by the Owner's consent or lack of consent to Sunday work hereunder.

4-08 Owner Supervision. The work shall be subject at all times to the supervision and direction of the Owner and of his authorized assistants. To prevent disputes and litigations, it is mutually agreed that the City in all cases shall determine the amount or quantity of the various kinds of work and workmanship to be paid for under this Contract, and he shall decide all questions which may arise relative to the performance of the work covered by the Contract and any doubt as to the meaning of the Construction Specifications and Drawings, and any obscurity or discrepancy as to their wording and intent will be final and binding on both parties to this Contract. The City may amend or

correct any errors or omissions in the Construction Specifications and Drawings when such amendments or corrections are necessary to make definite the intent indicated by a reasonable interpretation of the Contract requirements.

#### 4-09 Supervision and Inspection.

- a. The Contractor shall cause the construction work on the Project to receive constant supervision by a competent superintendent (hereinafter called the "Superintendent") who shall be present at all times during working hours where construction is being carried on. The Contractor shall also employ, in connection with the construction of the Project, capable, experienced and reliable foremen and such skilled workmen as may be required for the various classes of work to be performed. Directions and instructions given to the superintendent shall be binding upon the Contractor.
- b. The Owner reserves the right to require the removal from the Project of any employee of the Contractor if in the judgment of the Owner such removal shall be necessary in order to protect the interest of the Owner. The Owner or the Supervisor, if any, shall have the right to require the Contractor to increase the number of its employees and to increase or change the amount or kind of tools and equipment if at any time the progress of the work shall be unsatisfactory to the Owner or Supervisor; but the failure of the Owner or Supervisor to give any such directions shall not relieve the Contractor of its obligations to complete the work within the time and in the manner specified in these PROJECT SPECIFICATIONS.
- c. The manner of construction of the Project shall be subject to the inspection and approval of the Owner. The Owner shall have the right to inspect all payrolls and other data and records of the Contractor and of any Subcontractor, relevant to the construction of the Project. The Contractor shall provide all reasonable facilities necessary for such inspection and tests and shall maintain an office at the site of the Project, with telephone service where obtainable and at least one office employee to whom directions and instructions of the Owner may be delivered. Delivery of such directions or instructions, in writing, to the employee of the Contractor at such office shall constitute delivery to the Contractor. The Contractor shall have an authorized agent accompany the City when final inspection is made and, if requested by the Owner, when any other inspection is made.
- d. In the event that the Owner shall determine that the construction contains or may contain numerous defects, it shall be the duty of the Contractor and the Contractor's surety or sureties to have an inspection made by an City, approved by the Owner, for the purpose of determining the exact nature, extent and location of such defects.
- e. The City may recommend to the Owner that the Contractor suspend the work wholly or in part for such period or periods as the City may deem

necessary due to unsuitable weather or such other conditions as are considered unfavorable for the satisfactory prosecution of the work or because of the failure of the Contractor to comply with any of the provisions of the Contract. Provided, however, that the Contractor shall not suspend work pursuant to this provision without written authority from the Owner so to do. The time of completion hereinabove set forth shall be increased by the number of days of any such suspension, except when such suspension is due to the failure of the Contractor to comply with any of the provisions of this Contract. In the event that work is suspended by the Contractor with the consent of the Owner, the Contractor, before resuming work, shall give the Owner at least twenty-four (24) hours notice thereof, in writing.

#### 4-10 Defective Materials and Workmanship.

- a. The acceptance of any workmanship by the Owner shall not preclude the subsequent rejection thereof if such workmanship shall be found to be defective after installation, and any such workmanship found defective before final acceptance of the construction shall be remedied by and at the expense of the Contractor. Any such condemned work shall be immediately remedied by the Contractor at Contractor's expense. The Contractor shall not be entitled to any payment hereunder so long as any defective workmanship in respect to the Project, of which the Contractor shall have had notice, shall not have been remedied, as the case may be.
- b. Notwithstanding any certificate which may have been given by the Owner, if any workmanship which does not comply with the requirements of this Contract shall be discovered within one (1) year after completion of Construction of the Project, the Contractor shall remedy after notice, in writing, of the existence thereof shall have been given by the Owner. If the Contractor shall be called upon to remedy defective workmanship as herein provided, the Owner, if so requested by the Contractor, shall de-energize that section of the Project involved in such work. In the event of failure by the Contractor so to do, the Owner may remedy such defective workmanship and in such event the Contractor shall pay to the Owner the cost and expense thereof.

4-11 Patent Infringement. The Contractor shall save harmless and indemnify the Owner from any and all claims, suits and proceedings for the infringement of any patent or patents covering any materials or equipment used in construction of the Project.

4-12 Permits for Explosives. Not applicable.

4-13 Laws, Codes, Rules, Etc. The Contractor shall give all notices and comply with all laws, ordinances, rules and regulations bearing on the conduct of work. If the Contractor shall observe that the Construction Specifications and Drawings are at variance therewith, he shall promptly notify the Owner, in writing, and any necessary changes shall be adjusted as provided in the Contract for changes (Section 4-07 hereof). If the

Contractor performs any work knowing it to be contrary to such laws, ordinances, rules and regulations and without written notice to the Owner, he shall bear all costs arising therefrom. Where work required by the Construction Specifications and Drawings is more than the amount required by said laws, ordinances, rules and regulations, such work shall be as shown or specified. All work shall conform to the codes, rules and regulations of the National Board of Fire Underwriters, Public Corporations and other having jurisdiction. All necessary permits and licenses shall be provided by the Contractor, including City License.

4-14 Examinations of Premises. The Contractor is held to have previously examined the premises and to be satisfied as to the condition under which he will be obliged to operate in performing his part of the work or that will in any manner effect the work under this Contract.

4-15 Contractor's Measurements. Before ordering any material or doing any work, the Contractor shall take or verify all measurements from the property line or reference points as may be required for the proper fitting of his work to other adjoining work. The Contractor shall be responsible for the correctness of his figures and satisfactorily correct without charge any work which does not fit and furnish new work if necessary. No extra charges will be allowed on account of minor differences between actual dimensions and measurements indicated on the drawings; any difference which may be found shall be submitted to the City for his consideration before proceeding with the work.

4-16 Information from City. Dimensions and other information, whether on the Drawings or in the Construction Specifications or other documents or given orally, concerning lot sizes, ground elevations, present obstructions on or near the site, the position of tracts, etc., and the nature of the ground, have been obtained from sources which the City believes to be reliable but the accuracy of such information is not guaranteed. The information is furnished solely for the accommodation of the Contractor and the use of such dimensions and other information is made at the Contractor's own risk.

4-17 Decision of Disputed Questions. To prevent all disputed questions and litigations, it is further agreed by both parties hereto that the City shall in all cases determine the amount and quantity or the classification of the several kinds of work which is to be paid for under this agreement and he shall decide all questions which may arise, relative to the execution of this agreement, and his decision shall be final and binding on both parties.

4-18 Arbitration. Any disagreement arising out of this Contract or for the breach thereof, shall be submitted to arbitration and this agreement shall be specifically enforceable under the prevailing arbitration law, and judgment upon the award rendered may be entered in the highest court of the forum, State or Federal, have jurisdiction. It is mutually agreed that the decision of the arbitrators shall be a condition precedent to any right of legal action that either party may have against the other.

The parties may agree upon one arbitrator, otherwise there shall be three (3), one named in writing by each party of this Contract within five (5) days after notice of arbitration is served by either party upon the other; and a third arbitrator selected by these two

arbitrators within five (5) days thereafter. No one shall serve as an arbitrator who is in any way financially interested in this Contract or in the affairs of either party hereto.

4-19 Franchise and Rights-Of-Way. Not applicable.

4-20 Assignment. The Contractor shall not assign this Contract or any part hereof, or any monies due or to become due hereunder, without the approval of the Owner and without the consent of the surety unless the surety has waived its right to notice of assignment.

4-21 Subcontracting. No part of this Contract shall be sublet without the approval of the Owner. The Contractor shall be as fully responsible to the Owner for the acts and omissions of his subcontractor as he is for the acts and omissions of persons directly employed by himself.

The Contractor shall not be allowed to subcontract any appreciable part of said Contract without requiring a Contractor's Bond from the subcontractor indemnifying the Contractor and the Owner.

The Contractor must submit, with bid, a list of all subcontractors to be utilized in the construction of this project, along with a description of specific work to be performed by each said subcontractor.

4-22 Protection to Persons and Property. The Contractor shall at all times take all reasonable precautions for the safety of employees on the work and of the public, and shall comply with all applicable provisions of Federal, State and Municipal safety laws and building and construction codes, as well as the safety rules and regulations of the Owner. All machinery and equipment and other physical hazards shall be guarded in accordance with the "Manual of Accident Prevention in Construction" of the Associated General Contractors of America unless such instructions are incompatible with Federal, State or Municipal laws or regulations.

The following provisions shall not limit the generality of the above requirements:

- a. The Contractor shall at no time and under no circumstance cause or permit any employee of the Contractor to perform any work upon energized lines, or upon poles carrying energized lines, unless otherwise specified in the Notice and Instructions to Bidders.
- b. The Contractor shall so conduct the construction of the Project as to cause the least possible obstruction of Public Highways.
- c. The Contractor shall provide and maintain all such watchmen, guard lights and other protection for the public as may be required by applicable statutes, ordinances and regulations or by local conditions.
- d. The Contractor shall do all things necessary or expedient properly to protect any and all parallel, converging and intersecting lines, joint line poles,



highways and any and all property of others from damage, and in the event that any such parallel, converging and intersecting lines, joint line poles, highways or other property are damaged in course of the construction of the Project the Contractor shall at its own expense restore any or all of such damaged property immediately to as good a state as before such damage occurred.

- e. The Project, from the commencement of work to completion or to such earlier date or dates when the Owner may take possession and control in whole or in part as hereinafter provided, shall be under the charge and control of the Contractor and during such period of control by the Contractor all risks in connection with the construction of the Project and the materials to be used therein shall be borne by the Contractor. The Contractor shall make good and fully repair all injuries and damages to the Project or any portion thereof under the control of the Contractor by reason of any act of God or other casualty or cause whether or not the same shall have occurred by reason of the Contractor's negligence. The Contractor shall hold the Owner harmless from any and all claims for injuries to persons or for damage to property happening by reason of any negligence on the part of the Contractor or any of the Contractor's agents or employees during the control by the Contractor of the Project or any part thereof.
- f. Any and all excess earth, rock, debris, underbrush and other useless material shall be removed by the Contractor from the site of the Project as rapidly as practicable as the work progresses.
- g. Upon violation by the Contractor of any of the provisions of this section, after written notice of such violation given to the Contractor by the City or the Owner, the Contractor shall immediately correct such violation. Upon failure of the Contractor so to do the Owner may correct such violations at the Contractor's expense; provided, however, that the Owner may, if it deems it necessary or advisable, correct such violation at the Contractor's expense without such prior notice to the Contractor.
- h. The Contractor shall submit to the Owner weekly reports, in duplicate, of all accidents giving such data as may be prescribed by the Owner.

## 4-23 Contractor's Insurance.

### **City of Fairhope INSURANCE REQUIREMENTS**

#### **4.-23-0 INSURANCE REQUIREMENTS**

Awarded Contractor, at its sole expense, shall obtain and maintain in full force the following insurance to protect the Contractor and the City of Fairhope at limits and coverages specified herein. The City of Fairhope will be listed as an additional insured under the Contractor's General Liability insurance and automobile liability insurance policies, and all other applicable policies and certificates of insurance. These limits and coverages specified are the minimum to be maintained and are not intended to represent the correct insurance needed to fully and adequately protect the awarded Bidder.

**4-23-01** All insurance will be provided by insurers by admitted carriers in the State of Alabama, shall have a minimum A.M. Best rating of A-VII and must be acceptable to the CITY. Self-insured plans and/or group funds not having an A.M. Best rating must be submitted to the CITY for prior approval.

#### **4-23-02 NO WORK IS TO BE PERFORMED UNTIL PROOF OF COMPLIANCE WITH THE INSURANCE REQUIREMENTS HAS BEEN RECEIVED BY THE CITY.**

#### **4-23-03 Worker's Compensation and Employer's Liability**

Part One:	Statutory Benefits as required by the State of Alabama		
Part Two:	Employer's Liability	\$1,000,000	each accident
		\$1,000,000	each employee
		\$1,000,000	Policy Limit

#### **4.-23-04 U.S. Longshoreman & Harbor Workers Act (USL&H)**

Required if contract involves work near a navigable waterway that may be subject to the USL&H law.

#### **4-23-05 Maritime Endorsement (Jones Act)**

Endorsement required if contract involves the use of a Vessel. Or include coverage for "Master Member or Crew" under "Protection and Indemnity" coverage (P&I) unless crew is covered under

Workers Compensation.

Bodily injury by accident	\$1,000,000	each accident
Bodily injury by disease	\$1,000,000	aggregate

#### **4.-23-06 Commercial General Liability**

Coverage on an Occurrence from with a combined single limit of (Bodily Injury and Property Damage combined as follows:

Each occurrence	\$1,000,000
Personal and Advertising Injury	\$1,000,000
Products/Completed Operation Aggregate	\$2,000,000
General Aggregate	\$2,000,000

Coverage to include:

- Premises and operations
- Personal injury and Advertising Injury
- Products/completed operations
- Independent Contractors
- Blanket Contractual Liability
  - Explosion, Collapse and Underground hazards
- Broad Form Property Damage
- Railroad Protective Liability Insurance if work involves construction, demolition, or maintenance operations on or within 50 feet of a railroad.

#### **4-23-07 Automobile Liability**

Covering all owned, non-owned and hired vehicles with a limit of no less than \$1,000,000

combined single limit of Bodily injury and property damage per occurrence.

**4-23-08**      **Certificates of Insurance**

A Certificate of Insurance evidencing the above minimum requirements must be provided to and accepted by the CITY PRIOR to commencement of any work on the contract. Each policy shall be endorsed to provide ten (10) days written notice of cancellation to the CITY.

**4-23-09** The Contractor shall require certificates of insurance from sub-Contractors. Sub-Contractors will carry limits of insurance equal to or greater than those carried by the Contractor. These certificates shall evidence waivers of subrogation in favor of the Contractor and the CITY, and shall be made available to the CITY upon request.

C.      Property Insurance

CONTRACTOR shall purchase and maintain property insurance upon the Work at the Site in the amount of the full replacement cost thereof. This insurance shall:

1. include the interests of OWNER, CONTRACTOR, Subcontractors, CITY, CITY'S Consultants and any other individuals or entities identified in the Supplementary Conditions, and the officers, directors, partners, employees, agents and other consultants and subcontractors of any of them each of whom is deemed to have an insurable interest and shall be listed as an insured or additional insured;
2. be written on a Builder's Risk "all-risk" or open peril or special causes of loss policy form that shall at least include insurance for physical loss and damage to the Work, temporary buildings, falsework, and materials and equipment in transit and shall insure against at least the following perils or causes of loss: fire, lightning, extended coverage, theft, vandalism and malicious mischief, earthquake, collapse, debris removal, demolition occasioned by enforcement of Laws and Regulations, water damage, and such other perils or causes of loss as may be specifically required by the Supplementary Conditions.
3. include expenses incurred in the repair or replacement of any insured property (including but not limited to fees and charges of City);
4. cover materials and equipment stored at the Site or at another location that was agreed to in writing by OWNER prior to being incorporated in the Work, provided that such materials and equipment have been included in an Application for Payment recommended by CITY; and
5. allow for partial utilization of the Work by OWNER;
6. include testing and startup; and
7. be maintained in effect until final payment is made unless otherwise agreed to in writing by OWNER, CONTRACTOR and CITY with 30 days written notice to each other additional insured to whom a certificate of insurance has been issued.

D. Waiver of Rights

1. OWNER and CONTRACTOR intend that all policies purchased in accordance with paragraph 4.23 will protect OWNER, CONTRACTOR, Subcontractors, and CITY to be listed as **insureds or additional insureds** (and the officers, directors, partners, employees, agents, and other consultants and subcontractors of each and any of them) in such policies and will provide primary coverage for all losses and damages caused by the perils or causes of loss covered thereby. All such policies shall contain provisions to the effect that in the event of payment of any loss or damage the insurers will have no rights of recovery against any of the insureds or additional insureds thereunder. OWNER and CONTRACTOR waive all rights against each other and their respective officers, directors, partners, employees, agents, and other consultants and subcontractors of each and any of them for all losses and damages caused by, arising out of or resulting from any of the perils or causes of loss covered by such policies and any other property insurance applicable to the Work; and, in addition, waive all such rights against Subcontractors, and CITY to be listed as insureds or additional insureds (and the officers, directors, partners, employees, agents, and other consultants and subcontractors of each and any of them) under such policies for losses and damages so caused. None of the above waivers shall extend to the rights that any party making such waiver may have to the proceeds of insurance held by OWNER as trustee or otherwise payable under any policy so issued.
2. OWNER waives all rights against CONTRACTOR, Subcontractors, CITY, CITY's Consultants, and the officers, directors, partners, employees, agents, and other consultants and subcontractors of each and any of them for:
  - a. loss due to business interruption, loss of use, or other consequential loss extending beyond direct physical loss or damage to OWNER's property or the Work caused by, arising out of, or resulting from fire or other peril whether or not insured by OWNER; and
  - b. loss or damage to the completed Project or part thereof caused by, arising out of, or resulting from fire or other insured peril or cause of loss covered by any property insurance maintained on the completed Project or part thereof by OWNER during partial utilization, after Substantial Completion, or after final payment.
3. Any insurance policy maintained by OWNER covering any loss, damage or consequential loss shall contain provisions to the effect that in the event of payment of any such loss, damage, or consequential loss, the insurers will have no rights of recovery against CONTRACTOR, Subcontractors, CITY, or CITY's Consultants and the officers, directors, partners, employees, agents, and other consultants and subcontractors of each and any of them.

E. Use of Site and Other Areas

1. Limitation on Use of Site and Other Areas

- a. CONTRACTOR shall confine construction equipment, the storage of materials and equipment, and the operations of workers to the Site and other areas permitted by Laws and Regulations, and shall not unreasonably encumber the Site and other areas with construction equipment or other materials or equipment. CONTRACTOR shall assume full responsibility for any damage to any such land or area, or to the owner or occupant thereof, or of any adjacent land or areas resulting from the performance of the Work.
  - b. Should any claim be made by any such owner or occupant because of the performance of the Work, CONTRACTOR shall promptly settle with such other party by negotiation or otherwise resolve the claim by arbitration or other dispute resolution proceeding or at law.
  - c. To the fullest extent permitted by Laws and Regulations, CONTRACTOR shall indemnify and hold harmless OWNER, CITY, and the officers, directors, partners, employees, agents, and other consultants of each and any of them from and against all claims, costs, losses, and damages (including but not limited to all fees and charges of City attorneys, and other professionals and all court or arbitration or other dispute resolution costs) arising out of or relating to any claim or action, legal or equitable, brought by any such owner or occupant against OWNER, CITY, or any other party indemnified hereunder to the extent caused by or based upon Contractor's performance of the Work.
2. Removal of Debris During Performance of the Work: During the progress of the Work CONTRACTOR shall keep the Site and other areas free from accumulations of waste materials, rubbish, and other debris. Removal and disposal of such waste materials, rubbish, and other debris shall conform to applicable Laws and Regulations.
3. Cleaning: Prior to Substantial Completion of the Work CONTRACTOR shall clean the Site and make it ready for utilization by OWNER. At the completion of the Work CONTRACTOR shall remove from the Site all tools, appliances, construction equipment and machinery, and surplus materials and shall restore to original condition all property not designated for alteration by the Contract Documents.
4. Loading Structures: CONTRACTOR shall not load nor permit any part of any structure to be loaded in any manner that will endanger the structure, nor shall CONTRACTOR subject any part of the Work or adjacent property to stresses or pressures that will endanger it.

## F. Indemnification

1. To the fullest extent permitted by Laws and Regulations, CONTRACTOR shall indemnify and hold harmless OWNER, CITY, CITY's Consultants, and the officers, directors, partners, employees, agents, and other consultants and subcontractors of each and any of them from and against all claims, costs, losses, and damages (including but not limited to all fees and charges of City attorneys, and other professionals and all court or arbitration or other dispute resolution costs) arising out of or relating to the performance of the Work, provided that any such claim, cost, loss, or damage:
  - a. is attributable to bodily injury, sickness, disease, or death, or to injury to or destruction of tangible property (other than the Work itself), including the loss of use resulting therefrom; and
  - b. is caused in whole or in part by any negligent act or omission of CONTRACTOR, any Subcontractor, any Supplier, or any individual or entity directly or indirectly employed by any of them to perform any of the Work or anyone for whose acts any of them may be liable, regardless of whether or not caused in part by any negligence or omission of an individual or entity indemnified hereunder or whether liability is imposed upon such indemnified party by Laws and Regulations regardless of the negligence of any such individual or entity.
2. In any and all claims against OWNER or CITY or any of their respective consultants, agents, officers, directors, partners, or employees by any employee (or the survivor or personal representative of such employee) of CONTRACTOR, any Subcontractor, any Supplier, or any individual or entity directly or indirectly employed by any of them to perform any of the Work, or anyone for whose acts any of them may be liable, the indemnification obligation under paragraph F.1. shall not be limited in any way by any limitation on the amount or type of damages, compensation, or benefits payable by or for CONTRACTOR or any such Subcontractor, Supplier, or other individual or entity under workers' compensation acts, disability benefit acts, or other employee benefit acts.
3. The indemnification obligations of CONTRACTOR under paragraph F.1. shall not extend to the liability of CITY Consultants or to the officers, directors, partners, employees, agents, and other consultants and subcontractors of each and any of them arising out of:
  - a. the preparation or approval of, or the failure to prepare or approve, maps, Drawings, opinions, reports, surveys, Change Orders, designs, or Specifications; or
  - b. giving directions or instructions, or failing to give them, if that is the primary cause of the injury or damage.

4-24 Equal Employment Opportunity. During the performance of this Contract the Contractor agrees as follows:

- a. The Contractor will not discriminate against any employee or applicant for employment because of race, creed, color or national origin. The Contractor will take affirmative action to ensure that applicants are employed and that employees are treated during employment, without regard to their race, creed, color or national origin. Such action shall include, but not be limited to, the following: employment, upgrading, demotion or transfer; recruitment or recruitment advertising; layoff or termination; rates of pay or other forms of compensation; and selection for training, including apprenticeship. The Contractor agrees to post in conspicuous places, available to employees and applicants for employment, notices to be provided setting forth the provisions of this nondiscrimination clause.
- b. The Contractor will, in all solicitations or advertisements for employees placed by or on behalf of the Contractor, state that all qualified applicants will receive consideration for employment without regard to race, creed, color or national origin.
- c. The Contractor will send to each labor union or representative of workers with which he has a collective bargaining agreement or other contract or understanding, a notice to be provided advising the labor union or workers' representative of the Contractor's commitments under Section 202 of Executive Order No. 11246 of September 24, 1965 and shall post copies of the notice in conspicuous places available to employees and applicants for employment.
- d. The Contractor will comply with all provisions of Executive Order No. 11246 of September 24, 1965 and of the rules, regulations and relevant orders of the Secretary of Labor.
- e. The Contractor will furnish all information and reports required by Executive Order No. 11246 of September 24, 1965, and by the rules, regulations and orders of the Secretary of Labor, or pursuant thereto and will permit access to his books, records and accounts by the Department of Housing and Urban Development and the Secretary of Labor for purposes of investigation to ascertain compliance with such rules, regulations and orders.
- f. In the event of the Contractor's noncompliance with the nondiscrimination clauses of this Contract or with any of such rules, regulations or orders, this Contract may be canceled, terminated or suspended in whole or in part and the Contractor may be declared ineligible for further Government contracts or Federally-assisted construction contracts, in accordance with procedures authorized in Executive Order No. 11246 of September 24, 1965, and such other sanctions may be imposed and remedies invoked as provided in Executive Order No. 11246 of September 24, 1965, or by rule, regulation or order of the Secretary of Labor or as otherwise provided by law.

- g. The Contractor will include the provisions of (a) through (g) in every subcontract or purchase order unless exempted by rules, regulations or orders of the Secretary of Labor issued pursuant to Section 204 of Executive Order No. 11246 of September 24, 1965, so that such provisions will be binding upon each Subcontractor or vendor. The Contractor will take such action with respect to any Subcontractor or purchase order as the Department of Housing and Urban Development may direct as a means of enforcing such provisions, including sanctions for noncompliance. Provided, however, that in the event the Contractor becomes involved in, or is threatened with, litigation with a Subcontractor or vendor as a result of such direction by the Department of Housing and Urban Development, the Contractor may request the United States to enter into such litigation to protect the interests of the United States.

4-25 Partial Payments. Provided the City receives an Estimate Of Work Performed by the 1st day of each calendar month, then no later than the 23rd day of each such calendar month, the Owner will make partial payment to the Contractor on the basis of a duly certified approved estimate of the work performed during the preceding calendar month by the Contractor, but the Owner will retain 5% of the amount of each such estimate, until final completion and acceptance of all work covered by this Contract.

The Contractor shall pay: (1) for all transportation and utility services according to the rules and regulations of the agency involved, (2) for all tools and other material/equipment, to the extent of 95% of the cost thereof, not later than the 30th day following the completion of that part of the work in or on which such tools and equipment are used and (3) to each of his Subcontractors, not later than the 5th day following each payment to the Contractor, the respective amounts allowed the Contractor on account of the work performed by his Subcontractors, to the extent of each Subcontractor's interest therein, and the bond executed by the Contractor shall indemnify the Owner against any liability thereof.

4-2 6 Owner's Right to Withhold Payments. The Owner may withhold or, on account of subsequently discovered evidence, nullify the whole or a part of any certificate to such extent as may be necessary to protect it from loss on account of:

- a. Defective work not remedied.
- b. Claims filed or reasonable evidence indicating probable filing of claims.
- c. Failure of Contractor to make payments properly to its Subcontractors or for material or labor.
- d. A reasonable doubt that the Contract can be completed for the balance then unpaid.

4-27 Energizing the Project. Prior to Completion of the project the Owner, upon written notice to the Contractor, may test the construction thereof by temporarily energizing any



portion or portions thereof. During the period of such test the portion or portions of the Project so energized shall be considered as within the possession and control of the owner. Upon written notice to the Contractor by the Owner of the completion of such test and upon de-energizing the lines involved therein, said portion or portions of the project shall be considered as returned to the possession and control of the Contractor.

4-28 Release of Liens and Certificate of Contractor. (See Sample) Upon the completion by the Contractor of the construction of the Project, but prior to final payment to the Contractor, the Contractor shall deliver to the Owner releases of all liens and of rights to claim any lien, in the form of Paragraph 33 of this section, from all Subcontractors furnishing services for the Project and a certificate in the form of Paragraph 34 of this section to the effect that all labor used on or for the Project has been paid and that all such releases have been submitted to the Owner. Copy from newspaper of advertising completion of project in local newspaper for four (4) consecutive weeks (1day per week) shall also be submitted at this point.

Upon Completion of Construction by the Contractor, the City will prepare a Certificate of Completion. Upon the approval of such certificate by the Owner, the Owner shall make payment to the Contractor of all amounts to which the Contractor shall be entitled thereunder which shall not have been paid; provided, however, that such final payment shall be made not later than ninety (90) days after the date of Completion of Construction of the Project, as specified in the Certificate of Completion, unless withheld because of the fault of the Contractor.

4-29 Completion on Contractor's Default. If default shall be made by the Contractor or by any Subcontractor in the performance of any of the terms of this Proposal, the Owner, without in any manner limiting its legal and equitable remedies in the circumstances, may serve upon the Contractor and the Surety or Sureties upon the Contractor's Bond or Bonds a written notice requiring the Contractor to cause such default to be corrected forthwith. Unless within twenty (20) days after the service of such notice upon the Contractor such default shall be corrected or arrangements for the correction thereof satisfactory to the Owner shall be made by the Contractor or its Surety or Sureties, the Owner may take over the construction of the Project and prosecute the same to completion by Contract or otherwise for the account and at the expense of the Contractor, and the Contractor and its Surety or Sureties shall be liable to the Owner for any cost or expense in excess of the Contract price occasioned thereby. In such event the Owner may take possession of and utilize, in completing the construction of the Project, any materials, tools, supplies, equipment, appliances and plant belonging to the Contractor or any of its Subcontractors, which may be situated at the site of the Project. The Owner in such contingency may exercise any rights, claims or demands which the Contractor may have against third persons in connection with this Contract and for such purpose the Contractor does hereby assign, transfer and set over unto the Owner all such rights, claims and demands.

4-30 Cumulative Remedies. Every right or remedy herein conferred upon or reserved to the Owner shall be cumulative, shall be in addition to every right and remedy now or hereafter existing at law or in equity or by statute and the pursuit of any right or remedy

shall not be construed as an election. Provided, however, that the provisions of Paragraph 31 of this Section shall be the exclusive measure of damages for failure by the Contractor to complete the construction of the Project within the time herein agreed upon.

4-31 Indemnity. The Contractor agrees to save harmless and indemnify the Owner from and against all claims and demands of any person or persons whomsoever, as well as all costs, expenses, damages and attorney's fee for which said Owner may become liable or answerable by reason of any claim or demand of any such person or persons, resulting or arising from the performance of this Contract.

4-32 Venue. The parties agree that in the event that legal action shall be brought by either party against the other relative to any disagreement arising out of this Contract, such legal action shall be brought in a State Court of competent jurisdiction located in Baldwin County, Alabama.

# CITY OF FAIRHOPE

## STANDARD TERMS & CONDITIONS

### 1. ACCEPTANCE OF AGREEMENT

This Agreement contains all terms and conditions agreed upon by the OWNER and Winning bidder. No other agreement, oral or otherwise, regarding the subject matter of this Agreement shall be deemed to exist or to bind either party hereto. The Winning Bidder shall not employ Subcontractors without the express written permission of the OWNER. No waiver, alteration, consent or modification of any of the provisions of the Agreement shall be binding unless in writing and signed by the OWNER and CONTRACTOR. This Agreement shall not be construed against the party or parties preparing it. It shall be construed as if all the parties and each of them jointly prepared this Agreement, and any uncertainty or ambiguity shall not be interpreted against one or more parties.

### 2. ACCEPTANCE OF WORK

The City of Fairhope will be deemed to have accepted the Work after the City of Fairhope agrees the Work is completed by signature on delivery or service tickets. In the event Work furnished under the Contract / Agreement / Purchase Order is found to be defective or does not conform to the intent of the Contract / Agreement / Purchase Order, the awarded vendor shall, after receipt of notice from the City of Fairhope, correct the deficiencies. Failure on the part of the awarded vendor to properly correct the deficiencies within the time period allowed will constitute the City of Fairhope's right to cancel the Contract / Agreement / Purchase Order immediately, upon written notice to the awarded vendor.

### 3. ADDENDA

All Addenda are part of the Contract Documents. Include resultant costs in the Bid. Addenda will be issued by email to all Bidders on record and posted to the City of Fairhope website [www.fairhopeal.gov](http://www.fairhopeal.gov). It is the responsibility of the bidder to verify that all addenda have been received, and to include all signed addenda in the bid submission

### 4. ADDITIONAL ORDERS

Unless it is specifically stated to the contrary in the bid response, the City of Fairhope reserves the option to place additional orders against a contract awarded as a result of this solicitation at the same terms and conditions; to extend the renewal date until a new bid is in place, if it is mutually agreeable.

### 5. APPLICABLE LAW

This Agreement is deemed to be under and shall be governed by and construed according to the laws of the State of Alabama. Any litigation arising out of the Agreement shall be heard in the Courts of Baldwin County, Alabama.

### 6. ASSIGNMENT

The awarded vendor shall not assign the Contract / Agreement /Purchase Order or sublet it as a whole without the express written permission of the City of Fairhope. The awarded vendor shall not assign any payment due them hereunder, without the express written permission of City of Fairhope. The City of Fairhope may assign the Contract / Agreement / Purchase Order, or sublet it as a whole, without the consent of the awarded vendor.

### 7. ASSURANCE OF NON-CONVICTION OF BRIBERY

The bidder hereby declares and affirms that, to its best knowledge, none of its officers, directors, or partners and none of its employees directly involved in obtaining contracts has been convicted of bribery, attempted bribery or conspiracy to bribe under the laws of any state or Federal government.

### 8. AWARD CONSIDERATION

The following factors will be considered in determining the lowest **responsible** bidder: Overall quality, Conformity with specifications both general and specific, Purposes for which materials or services are required, Delivery dates and time required for delivery, Unit acquisition cost, financial ability to meet the contract, previous performance, facilities and equipment, availability of repair parts, experience, delivery promise, terms of payments, compatibility as required, other costs, and other objective and accountable factors which are reasonable.

### 9. AWARD OR REJECTION OF BIDS

The Bid will be awarded to the lowest responsible bidder complying with conditions of the invitation for bids, provided his bid is reasonable and it is in the interest of the City of Fairhope to accept it. The bidder to whom the award is made will be notified at the earliest possible date. The City of Fairhope, however, reserves the right to reject any and all bids and to waive any informality in bids received whenever such rejection or waiver is in the interest to the City of Fairhope.

### 10. BACK ORDERS

If it is necessary to back order any items, the vendor must notify the Purchasing Department and advise as to the expected shipping or delivery date. If this date is not acceptable, the City of Fairhope may seek remedies for default.

### 11. BID AND PERFORMANCE SECURITY

If bid security is required, a bid bond or cashier's check in the amount indicated on the bid cover must accompany the bid and be made payable to The City of Fairhope of Baldwin County, Al. Corporate or certified checks are not acceptable. Bonds must be in a form satisfactory to the City and underwritten by a company licensed to issue bonds in the State of Alabama. If bid security fails to accompany the bid, it shall be deemed unresponsive, unless the Purchasing Manager deems the failure to be non-substantial. All checks will be returned to the bidders after the contract has been Approved. If a performance bond is required, the successful bidder will be notified after the awarding of the contract.

### 12. BRAND NAMES

Reference to brand names and numbers is descriptive, but not restrictive, unless otherwise specified. Bids on equivalent items meeting the standards of quality thereby indicated will be considered, providing the bid clearly describes the article offered and indicates how it differs from the referenced brands. Descriptive literature or manufacturers specifications plus any supplemental information necessary for comparison purposes should be submitted with the bid or the bid on that item may be rejected. Reference to literature submitted with a previous bid or on file with the Division of Purchasing will not satisfy this requirement. The

burden is on the bidder to demonstrate that the item bid is equivalent to the item specified in the ITB. Bids without sufficient documentation to fully support equality, may be considered non-responsive. Reference by the City of Fairhope in the ITB to available existing specifications shall be sufficient to make the terms of such specifications binding on the bidder. Unless the bidder specifies otherwise in its bid, it is understood the bidder is offering a referenced brand item as specified in the ITB or is bidding as specified when no brand is referenced. Failure to examine drawings, specifications and instructions will be at the bidder's risk.

### **13. BUSINESS LICENSE**

The vendor selected to enter into a Contract / Agreement with the City of Fairhope must be licensed to do business in the City of Fairhope prior to commencement of any work under the contract. Delivery of goods or services to the City of Fairhope by Purchase Order have detailed and varied Business License requirements. In all instances that require a business license. Awarded vendor will provide proof of possessing a current City of Fairhope Business License. Prospective bidders will not be required to possess a City of Fairhope Business License prior to award.

### **14. CANCELLATION OF / CONTRACT / AGREEMENT / PURCHASE ORDER / LEASE**

A purchase order can be canceled in whole or in part when awarded vendor fails to deliver or perform as specified. Cancellation of a purchase order can only be made by a written purchase order change (POC) from the City of Fairhope. A term contract, lease or agreement can be canceled by the City of Fairhope, for justifiable cause, or convenience, by written notice.

### **15. CERTIFICATION PURSUANT TO ACT NO. 2006-557**

Alabama law (section 41-4-116, code of Alabama 1975) provides that every bid submitted, and contract executed shall contain a certification that the vendor, CONTRACTOR, and all of its affiliates that make sales for delivery into Alabama or leases for use in Alabama are registered, collecting, and remitting Alabama state and local sales, use, and/or lease tax on all taxable sales and leases into Alabama. By submitting this bid, the bidder is hereby certifying that they are in full compliance with act no. 2006-557, they are not barred from bidding or entering into a contract pursuant to 41-4-116, and acknowledges that the awarding authority may declare the contract void if the certification is false. All corporations must register to do business in Alabama with the Office of the Secretary of State. Their address is:

#### **Office of the Secretary of State**

P.O. Box 5616  
Montgomery, AL 36103  
(334) 242-5324  
Fax: (334) 240-3138

<http://www.sos.state.al.us/index.aspx>

The Foreign Corporation form is online at  
<http://www.sos.state.al.us/downloads/dl1.cfm>.

### **16. COST OF REMEDYING DEFECTS**

All defects, indirect and consequential costs of correcting, removing or replacing any or all of the defective materials or equipment will

be charged against the awarded vendor.

### **17. DELIVERY OF BID**

Bids must be received in the Purchasing Office by the date and time specified on the bid cover. All bids will be accepted until the time and date stated on the bid cover. No bids will be accepted that extend past the time and date on the bid cover. The time of receipt shall be determined by the time clock stamp in the Purchasing Department. Bids submitted by U.S. Mail must be received by the City of Fairhope of Baldwin County, Alabama, in the City of Fairhope offices, 555 South Section St., Fairhope, AL., unless otherwise specified.

### **18. DELIVERY**

The number of calendar days required for delivery after receipt of a purchase order shall be stated in the RFQ / ITB / RFP and /or Purchase Orders. When no time is stated in the document, the time shall be fourteen (14) calendar days after receipt of order. If a shipment is not made within the time period specified, the Purchase Order may be canceled.

### **19. ENVIRONMENTAL REQUIREMENTS**

All products will be clearly labeled for their intended use. Each delivery of product or materials will include a Material Safety Data Sheet (MSDS) for all materials that require an MSDS. All manufacturers/distributors of hazardous substances, including any of the items listed on this bid/quote/ contract and subsequent award must include completed material safety data sheet (MSDS) for each hazardous material. Additionally, each container of hazardous materials must be appropriately labeled with:

- a) The identity of the hazardous material,
- b) Appropriate hazard warnings, and manufacturer, importer, or other responsible party.

### **20. EQUIPMENT DEMONSTRATION**

The City of Fairhope may require equipment/ product materials or service techniques to be demonstrated at a time, date and location to be specified by the City of Fairhope.

### **21. EQUIPMENT ELECTRICAL CERTIFICATION**

All electrical equipment purchased shall conform to, and be identified in, the applicable standard(s), or otherwise be certified as applicable, as of the bid opening date and time, by Underwriters Laboratories, Inc. or other recognized laboratory facility. Bidder must provide satisfactory documentation with returned bid that all such equipment meets the applicable product standard or has otherwise been certified as outlined above. Unless indicated in the bid document, the above certification shall apply to the equipment itself, not the individual components of that equipment.

### **22. ERRORS IN BID**

Bidders are assumed to be informed regarding conditions, requirements and specifications prior to submitting bids. Failure to do so will be at the bidder's risk. Bids already submitted may be withdrawn without penalty prior to bid opening. Errors discovered after the bid opening may not be corrected.

### **23. FORCE MAJEURE**

Neither the City nor the awarded vendor shall be deemed in breach of any contract / Purchase Order or Agreement which may result

from this proposal submission if it is prevented from performing any of the obligations hereunder by reason of Acts of God, acts of the public enemy, acts of superior governmental authority, strikes or labor disputes, floods, riots, rebellion, sabotage, or any similar other unforeseeable causes beyond its control and not due to its fault or negligence. Each party shall notify the other immediately in writing of the cause of such after the beginning period thereof. The awarded vendor may request cancellation and the City of Fairhope may grant the request if performance is prevented by any of the above referenced causes, or other unavoidable circumstances not attributable to the fault or negligence of the vendor. The burden of proof for such relief rests with the vendor. All correspondence pertaining to cancellation of a purchase order or term contract must be addressed to the City of Fairhope Purchasing Manager.

#### **24. HAZARDOUS AND TOXIC SUBSTANCES**

Bidder must comply with all applicable Federal, State, County and City laws, ordinances and regulations relating to hazardous and toxic substances, including such laws, ordinances and regulations pertaining to information hazardous and toxic substances, and as amended from time to time. Bidder shall provide the City of Fairhope with a "Material Safety Data Sheet" for all goods that carry one.

#### **25. INDEMNITY**

Indemnity: The awarded vendor hereby agrees to indemnify and save harmless the City of Fairhope, its officers, agent, and employees, from and against any and all liabilities, claims, demands, damages, fines, fees, expenses, penalties, suits, proceedings, actions and cost of actions, including reasonable attorney's fees for trial and on appeal, of any kind and nature, arising or growing out of, or in any way connected with the performance of this Contract / Agreement / Purchase Order, to the extent caused by a negligent act or omission of the awarded vendor, their agents, servants, employees, Sub-contractors, or others associated with the awarded vendor. The awarded vendor shall be responsible for damage to any equipment excluded from this agreement, or damage or injury caused by any equipment excluded from this agreement, only to the extent that the damage or injury is caused by a negligent act or omission of the awarded vendor, or caused by failure of the awarded vendor's supplied product to perform as specified.

#### **26. INSPECTION**

All materials, workmanship, equipment, and supplies are subject to inspection and test at any source or time. Final inspection, acceptance or rejection will be made at delivery destination. Goods that do not meet specifications will be rejected unless substitutions have been approved by the City of Fairhope. Failure to inspect or to reject upon receipt, however, does not relieve the awarded vendor of liability. When subsequent tests, after receipt, are conducted and when such tests reveal a failure to meet specifications, the City of Fairhope will reject the goods and the awarded vendor shall immediately supply goods meeting specifications or the City of Fairhope may seek damages including but not limited to the testing expense, regardless of whether a part of or all of the goods have been consumed through the testing process. Rejected goods shall be removed by the awarded vendor promptly after rejection, at his expense. If not removed in fourteen (14) calendar days, they may be disposed of at the discretion of the City of Fairhope. Disposal costs will be the awarded vendor's

responsibility.

#### **27. INSPECTION OF PREMISES**

At reasonable times, the City may inspect those areas of the awarded vendor's place of business that are related to the performance of a Contract / Agreement / Purchase Order. If the City makes such an inspection, the awarded vendor must provide reasonable assistance. The City of Fairhope reserves the right on demand and without notice all the vendor's files associated with a subsequent Contract / Agreement / Purchase Order where payments are based on the awarded vendor's record of time, salaries, materials, or actual expenses. This same clause will apply to any sub-contractors assigned to the Contract / Agreement / Purchase Order.

#### **28. INSURANCE**

If a Contract / Agreement / Purchase Order results from this RFQ / ITB / RFP, or other form of solicitation, the awarded vendor shall maintain such insurance as will indemnify and hold harmless the City of Fairhope from Workmen's Compensation and Public Liability claims from property damage and personal injury, including death, which may arise from the awarded vendor's operations under this Contract / Agreement / Purchase Order, or by anyone directly or indirectly employed by him/her.

#### **29. INVITATION TO BID**

Any provisions made in the RFQ / ITB / RFP, or other form of solicitation, supersedes any provisions outlined here in the General Terms and Conditions.

#### **30. INVOICING, DELIVERY, PACKAGING**

Invoices shall be prepared only after ordered materials have been delivered. All invoices must show the purchase order number. Unless otherwise specified in writing, vendors shall not ship any material without an authorized Purchase Order from the City of Fairhope Purchasing Department. All packages delivered must show the purchase order number. The awarded vendor will be required to furnish all materials, equipment and/or service called for at the bid price quoted. In the event the awarded vendor fails to deliver within a reasonable period of time, as determined by the City of Fairhope, the right is reserved to cancel the award and subsequent purchase order and purchase from the next lowest responsible bidder the items needed. The original awarded vendor will be back charged the difference between the original contract price and the price the City of Fairhope has to pay as a result of the failure to perform by the original awarded vendor. All bids will remain firm for acceptance for 60 days from the date of bid opening. Prices shall be net F.O.B., Prepaid and Allow, City of Fairhope chosen site, Baldwin County, Al. The title and risk of loss of the goods will not pass to the City of Fairhope until receipt and acceptance takes place at the F.O.B. point.

#### **31. LABELING**

Individual shipping cartons shall be labeled with the name "City of Fairhope", Purchase Order Number, and where applicable, Contract Number, date of manufacture, batch number, storage requirements, conditions, and recommended shelf life. Bidders are encouraged to offer product packaging with recycled content.

#### **32. LOSS OR DAMAGE IN TRANSIT**

Delivery by a vendor to a common carrier does not constitute

delivery to the City of Fairhope. Any claim for loss or damage incurred during delivery shall be between the vendor and the carrier. The City of Fairhope accepts title only after satisfactory receipt at the delivery point. The City of Fairhope shall note all visible damages on the freight bill and may refuse the damaged goods. The vendor shall make immediate replacement of the damaged merchandise or be subject to damages for breach of contract. If damage is to a small portion of a total shipment and the City of Fairhope will not be inconvenienced because of the shortage, the vendor may be permitted by the Purchasing Manager to deduct the amount of damage or loss from its invoice, in lieu of replacement. Risk of loss during delivery is borne by the vendor until the goods have been accepted by the City of Fairhope, unless otherwise specified in the RFQ / ITB / RFP or other form of solicitation.

### **33. MANDATORY SITE VISIT**

If the RFQ / ITB / RFP or other form of solicitation requires a mandatory site visit, bidders must inspect the site where installation or service is to take place to obtain a full understanding of scope of work outlined therein. Date of site visit will be determined by the City of Fairhope.

### **34 MONITORING OF SERVICES**

Performance of services will be monitored by the requisitioning department and/or the Purchasing Department, and evaluation reports may be filed with the Purchasing Department. Performance not meeting specifications will result in cancellation of Contract / Agreement / Purchase Order and may result in vendor being removed from the vendor list.

### **35. NON-CONFORMING MERCHANDISE**

When merchandise received from the lowest responsible bidder is not in accordance with the purchase order, it will be returned to the bidder, at bidder's expense.

### **36. NON-DISCRIMINATION**

The City of Fairhope is an Equal Opportunity Employer and requires that all CONTRACTORS comply with the Equal Employment Opportunity laws and the provisions of the Contract / Agreement / Purchase Order documents in this regard. The City also encourages and supports the utilization of Minority Business Enterprises on this and all public bids.

### **37. NON-EXCLUSIVE**

Unless otherwise specified, this Contract / Agreement / Purchase Order is considered a non-exclusive Contract / Agreement / Purchase Order between the parties.

### **38. NOTIFICATION AND ACCIDENT REPORTS**

In the event of accidents of any kind, in the performance of a Contract / Agreement / Purchase Order, the awarded vendor shall notify the City of Fairhope immediately and furnish, without delay, copies of all such accident reports to the City of Fairhope. If in the performance of their Work, the awarded vendor fails to immediately report an accident to the City of Fairhope, of which the awarded vendor has knowledge of and which results in a fine levied against the City of Fairhope then the awarded vendor shall be responsible for all fines levied against the City of Fairhope.

### **39. PACKAGING**

All goods must be packaged in new packing containers. Packing that meets the requirements of common carriers is acceptable,

unless otherwise required. A packing slip or invoice must accompany all shipments and must reference the purchase order number. Unless otherwise specified, goods are to be packaged in cartons meeting federal specifications and shipped on non-returnable pallets.

### **40. PATENTS**

Awarded Vendor guarantees that the sale and / or use of goods will not infringe upon any U.S. or foreign patent. Awarded vendor will at his / her own expense, indemnify, protect and save harmless the City of Fairhope, on any patent claims arising from the purchase of goods or services.

### **41. PAYMENT**

Invoices -- Upon completion of service and delivery of materials specified in the applicable purchase order, awarded vendor will submit an invoice and signed delivery ticket to:

City of Fairhope  
Accounts Payable Department  
P.O. Drawer 429  
Fairhope, Al. 36533  
[ap@fairhopeal.gov](mailto:ap@fairhopeal.gov)

All invoices must reference appropriate Purchase Order Numbers  
Payment of Invoice: All invoices received by the City of Fairhope are payable within thirty (30) days from the date of receipt by the City of Fairhope, provided they are approved by the City of Fairhope.

### **42. PAYMENT WITHHELD**

Payment may be withheld until all items have been delivered and all requirements of the Contract / Agreement / Purchase Order have been fulfilled

### **43. PRODUCT TESTING**

Vendor shall incur all cost involved in obtaining an Independent Laboratory Test if the City deems necessary during the term of the Contract / Agreement / Purchase Order. The City of Fairhope reserves the right to request a demonstration of any and all items bid before making the award.

### **44. PERMITS LICENSES AND CERTIFICATES**

The awarded vendor is to procure all permits, licenses, and certificates, or any approvals of plans or specifications as may be required by Federal, State, Local Laws, ordinances, rules, and regulations, for the proper execution and completion of Work covered under the Contract / Agreement / Purchase Order.

### **45. PREPARATION OF BID**

All bids / proposals shall be typewritten or in ink on the form(s) prepared by the City of Fairhope. Bids / proposals prepared in pencil will not be accepted. All bids / proposals must be signed by officials of the corporation or company duly authorized to sign bids / proposals. Any bid / proposal submitted without being signed will automatically be rejected. All corrections or erasures shall be initialed and dated by the person authorized to sign quotations / bids / proposals. If there are discrepancies between unit prices quoted and extensions, the unit price will prevail.

### **46. QUESTIONS / CONTACT**

Commencing with the issuance of the RFQ / ITB / RFP, or other form of solicitation, no vendor or anyone acting on a vendor's behalf, shall make direct or indirect contact with City personnel or undertake any activities or take any action to otherwise promote its quotation / bid / proposal to the City or its personnel. All communications shall be made to the contact identified in the quotation / bid / proposal documents. Violation of this requirement may, at the City's sole and absolute discretion, be grounds for disqualifying a vendor from further consideration.

#### **47. RECEIPT BY CITY OF FAIRHOPE**

If not otherwise stated in the order, the City of Fairhope will be said to have received goods when they have been delivered, unloaded and placed on the agency's dock or if there is no dock, inside an accessible building, and signed for by an authorized City employee. Shipments will be checked against the receiving copy of the Purchase Order. If the purchase order requires grading certificates, USDA Stamps, or any proof of quality, such proof must accompany the shipment.

#### **48. REJECTION OF BIDS**

The City of Fairhope reserves the right to accept or reject any or all bids in whole or in part for any reason, to waive technicalities or informalities, or to advertise for new proposals, if, in the judgment of the awarding authority, the best interest of the City of Fairhope will be promoted thereby. Bidders may be disqualified and rejection of proposals may be recommended for any of (but not limited to) the following causes: Failure to use the bid forms furnished by the City of Fairhope, Lack of signature by an authorized representative on the bid form, Failure to properly complete the bid form and vendor compliance, Evidence of collusion among bidders, unauthorized alteration of the bid form.

#### **50. RIGHT TO AUDIT**

The awarded vendor shall maintain documentation of all work performed. The awarded vendor shall make any and all documentation available to the City of Fairhope at all reasonable times, for inspections and audit by the City of Fairhope, during the entire term of the Contract / Agreement / Purchase Order and for a period of Three (3) years after expiration of the Contract / Agreement / Purchase Order.

#### **51. SAMPLES**

Bidders will not be required to furnish samples at the time of bid opening, unless specifically called for. The City of Fairhope reserves the right to request samples after bid opening to assist in the evaluation of proposals submitted.

#### **52. SAFETY MEASURES**

The awarded vendor shall take all necessary precautions for the safety of the City of Fairhope's and awarded vendor's employees at the Work site, and shall erect and properly maintain at all times, all necessary safeguards for the protection of the workmen and the public. The awarded vendor shall post signs warning against hazards in and around the Work site.

#### **53. SET-UP AND INSTALLATION**

Unless otherwise specified, bid / quotation to include cost of all uncrating, disposal of shipping materials, set-up, testing and initial instruction to agency personnel.

#### **54. SPILL CLEAN UP**

The awarded vendor shall be responsible for spillage caused by their negligence, which occurs during transit or unloading operations. The awarded vendor shall immediately report and clean up any spillage. Upon failure to do so, the awarded vendor shall remain responsible for all actual related costs

#### **55. SUBSTITUTIONS**

Substitutions on a purchase order shall require the approval of the Originating Buyer. The City of Fairhope reserves the right to reject at destination and hold at the vendor's risk and expense any goods supplied by the vendor which do not conform to the specification or description embodied in the order or are inferior in any respect to the good specified. Any good bought by sample which is inferior in quality to the sample submitted by vendor will be rejected. Any goods delivered that do not meet specifications may be returned to the vendor at its expense. When a good is returned, the vendor must make immediate replacement with acceptable merchandise or the City of Fairhope may seek remedies for default.

#### **56. TABULATION**

Bid results are posted on The City of Fairhope's web site: [www.fairhopeal.gov](http://www.fairhopeal.gov). The awarded vendor will be sent a written notification via mail.

#### **57. TAXES**

Prices quoted shall be delivered prices, exclusive of all federal or state excise, sales, and manufacturer's taxes. The City will assume no transportation or handling charges other than specified in the RFQ, ITB, RFP or other form of solicitation. The City is tax exempt by law – Code of Alabama 1975.

#### **58. TERMINATION FOR CONVENIENCE**

Any Contract / Agreement / Purchase Order may be terminated for convenience by the City of Fairhope, in whole or in part, by written notification to the awarded vendor.

#### **59. TERMINATION FOR DEFAULT**

Performance of Work under the Contract / Agreement / Purchase Order Agreement may be terminated by the City of Fairhope, in whole or in part, in writing, whenever the City of Fairhope determines that the awarded vendor has failed to meet the requirements of the Contract / Agreement / Purchase Order.

#### **60. TERMINATION FOR NON-APPROPRIATION**

Termination for Non-appropriation – The continuation of any financial obligation beyond the current fiscal year is subject to and contingent upon sufficient funds being appropriated, budgeted, and otherwise made available by the local source, State Legislature and/or federal sources. The City of Fairhope may terminate any financial obligation, and awarded vendor waives any and all claim(s) for damages, effective immediately upon receipt of written notice (or any date specified therein) if for any reason the City of Fairhope's funding from local, State and/or federal sources is not appropriated, withdrawn or limited.

#### **61. TIME IS OF THE ESSENCE**

The City of Fairhope and awarded vendor agree that time is of the essence in the performance of work called for under this Contract / Agreement / Purchase Order. The awarded vendor agrees that all

work will be accomplished regularly, diligently and uninterrupted at such a rate of progress as will ensure full completion thereof within reasonable time periods.

#### **62. TITLE**

All titles, fees, as well as other charges, are to be paid by awarded vendor. Awarded vendor is to furnish prepaid certificate of title in the name of the City of Fairhope, Title shall change upon acceptance of delivery at the City of Fairhope approved delivery location.

#### **63. VENDOR LIST**

A vendor may be removed from the City of Fairhope's Bidders List if a vendor fails to respond to three (3) consecutive ITB's. A properly submitted "No Bid" is considered as a response and the vendor will receive credit for the response.

#### **64. WARRANTY**

The awarded vendor expressly warrants that all articles, materials, and work offered shall conform to each and every specification, drawing, sample, or other description which is furnished to or adopted by the City of Fairhope, and that it will be fit and sufficient

for the purpose intended, merchantable, of good material and workmanship, and free from defects. The awarded vendor further warrants all items for a period of one year, unless otherwise stated, from the date of acceptance of the items delivered and installed or work completed. All repairs, replacements, or adjustments during the warranty period will be at the awarded vendor's sole expense. Awarded vendor will provide written warranty for all parts and labor for a period of (1) one year commencing from date of written acceptance of delivery by City of Fairhope. Awarded vendor will provide written copies of all other applicable warranties, such as, Manufacturer's warranty. Those warranties, if any, will be in addition to the awarded vendor's warranty, and the terms of which will not be altered by the awarded vendor's warranty.

#### **65. IMMIGRATION LAW**

The CONTRACTOR agrees that it shall comply with all of the requirements of the **Beason-Hammon Alabama Taxpayer and Citizen Protection Act, Act No 2011-535**, Alabama Code (1975) Section 31-13-1, et. Seq., (also known as the Alabama Immigration Act) see Section 31-13-9, and the provisions of said Act, including all penalties for violation thereof, are incorporated herein.



## Alabama Immigration Act Contract Requirements

### 1.0 Background

The **Beason-Hammon Alabama Taxpayer and Citizen Protection Act, Act No 2011-535, as amended by Act No 2012-491, Code of Alabama (1975) Section 31-13-1 through Section 31-13-30** (also known as and hereinafter referred to as “the Alabama Immigration Act”) is applicable to contracts with the City of Fairhope, Alabama. All business entities entering into contracts with the City of Fairhope, Alabama will comply with the Alabama Immigration Act.

### 2.0 Definitions

**ALIEN.** Any person who is not a citizen or national of the United States, as described in 8 U.S.C. § 1101, et seq., and any amendments thereto.

**BUSINESS ENTITY.** Any person or group of persons employing one or more persons performing or engaging in any activity, enterprise, profession, or occupation for gain, benefit, advantage, or livelihood, whether for profit or not for profit. Business entity shall include but not be limited to the following:

- a. Self-employed individuals, business entities filling articles of incorporation, partnerships, limited partnerships, limited liability companies, foreign corporations, foreign limited partnerships, foreign liability companies authorized to transact business in this state, business trusts, and any business entity that registers with the Secretary of State.
- b. Any business entity that possesses a business license, permit, certificate, approval, registration, charter, or similar form of authorization issued by the state, any business entity that is exempt by law from obtaining such a business license, an any business entity that is operating unlawfully without a business license.

**CONTRACTOR.** A person, employer, or business entity that enters into an agreement to perform any service or work or to provide a certain product in exchange for valuable consideration. This definition shall include, but not be limited to, a general contractor, subcontractor, independent contractor, contract employee, project manager, or a recruiting or staffing entity.

**EMPLOYEE.** Any person directed, allowed, or permitted to perform labor or service of any kind by an employer. The employees of an independent contractor working for a business entity shall not be regarded as the employees of the business entity, for the purposes of this chapter. This term does not include any inmate in the legal custody of the state, a county, or a municipality.

**EMPLOYER.** Any person, firm, corporation, partnership, joint stock association, agent, manager, representative, foreman, or other person having control or custody of any employment, place of employment, or of any employee, including any person or entity employing any person for hire within the State of Alabama, including a public employer. This term shall not include the occupant of a household contracting with another person to perform casual domestic labor within the household.

**E-VERIFY.** The electronic verification of federal employment authorization program of the Illegal Immigration Reform and Immigrant Responsibility Act of 1996, P.L. 104-208, Division c, Section 403 (a); 8 U.S.C. §1324(a), and operated by the United States Department of Homeland Security, or its successor program.

**STATE-FUNDED ENTITY.** Any governmental entity of the state or a political subdivision thereof or any other entity that receives any monies from the state or a political subdivision thereof; provided, however, an entity that merely provides a service or a product to any governmental entity of the state or a political subdivision thereof, and receives compensation for the same, shall not be considered a state-funded entity.

**SUBCONTRACTOR.** A person, business entity, or employer who is awarded a portion of an existing contract by a contractor, regardless of its tier.

UNAUTHORIZED ALIEN. An alien who is not authorized to work in the United States as defined in 8 U.S.C. § 1324a (h) (3) .

3.0 Mandatory Clause

All contracts or agreements to which the state, a political subdivision, or state-funded entity are a party shall include the following clause:

***"By signing this contract, the contracting parties affirm, for the duration of the agreement, that they will not violate federal immigration law or knowingly employ, hire for employment, or continue to employ an unauthorized alien within the state of Alabama. Furthermore, a contracting party found to be in violation of this provision shall be deemed in breach of the agreement and shall be responsible for all damages resulting therefrom."***

For purposes of this section, "contract" shall mean a contract awarded by the state, any political subdivision thereof, or any state-funded entity that was competitively bid or would, if entered into by the state or an agency thereof, be required to be submitted to the Contract Review Permanent Legislative Oversight Committee.

4.0 Contracts Involving Business Entity, or Employer

As a condition for the award of any contract, grant, or incentive by the state, any political subdivision thereof, or any state-funded entity to a business entity or employer that employs one or more employees, the business entity or employer shall not knowingly employ, hire for employment, or continue to employ an unauthorized alien within the State of Alabama.

As a condition for the award of any contract, grant, or incentive by the state, any political subdivision thereof, or any state-funded entity to a business entity or employer that employs one or more employees within the state of Alabama, **the business entity or employer shall provide documentation establishing that the business entity or employer is enrolled in the E-Verify program.** During the performance of the contract, the business entity or employer shall participate in the E-Verify program and shall verify every employee that is required to be verified according to the applicable federal rules and regulations.

5.0 Contracts Involving Subcontracting

Any subcontractor on a project paid for by contract, grant, or incentive by the state, any political subdivision thereof, or any state-funded entity shall not knowingly employ, hire for employment, or continue to employ an unauthorized alien within the State of Alabama and shall also enroll in the E-Verify program prior to performing any work on the project. Furthermore, during the performance of the contract, the subcontractor shall participate in the E-Verify program and shall verify every employee that is required to be verified according to the applicable federal rules and regulations. This subsection shall only apply to subcontractors performing work on a project subject to the provisions of this section and not to collateral persons or business entities hired by the subcontractor.

6.0 Proof of E-Verify documentation will be in the form of a copy of the signed Memorandum Of Understanding (MOU) generated upon completion of the E-Verify program.

## **ATTACHMENT B**

### **FEMA FEDERAL CONTRACT PROVISIONS**

#### **A. EQUAL EMPLOYMENT OPPORTUNITY CLAUSE (2 CFR §200.326 Appendix II to Part 200 (C) )**

During the performance of the contract, CONTRACTOR shall comply with the Equal Employment Opportunity Clause (41 CFR 60-1.4(b)):

1. CONTRACTOR will not discriminate against any employee or applicant for employment because of race, color, religion, sex, or national origin. CONTRACTOR will take affirmative action to ensure that applicants are employed, and that employees are treated during employment without regard to their race, color, religion, sex, or national origin. Such action shall include, but not be limited to the following: Employment, upgrading, demotion, or transfer; recruitment or recruitment advertising; layoff or termination; rates of pay or other forms of compensation; and selection for training, including apprenticeship. CONTRACTOR agrees to post in conspicuous places, available to employees and applicants for employment, notices to be provided setting forth the provisions of this nondiscrimination clause.
2. CONTRACTOR will, in all solicitations or advertisements for employees placed by or on behalf of the CONTRACTOR, state that all qualified applicants will receive considerations for employment without regard to race, color, religion, sex, or national origin.
3. CONTRACTOR will send to each labor union or representative of workers with which he has a collective bargaining agreement or other contract or understanding, a notice to be provided advising the said labor union or workers' representatives of the CONTRACTOR's commitments under this section, and shall post copies of the notice in conspicuous places available to employees and applicants for employment.
4. CONTRACTOR will comply with all provisions of Executive Order 11246 of September 24, 1965, and of the rules, regulations, and relevant orders of the Secretary of Labor.
5. CONTRACTOR will furnish all information and reports required by Executive Order 11246 of September 24, 1965, and by rules, regulations, and orders of the Secretary of Labor for purpose of investigation to ascertain compliance with such rules, regulations, and orders.
6. In the event of the CONTRACTOR's noncompliance with the nondiscrimination clauses of this Contract or with any of the said rules, regulations or orders, this contract may be canceled, terminated, or suspended in whole or in part and the CONTRACTOR may be declared ineligible for further Government contracts or federally assisted construction contracts in accordance with procedures authorized in Executive Order 11246 of September 24, 1965, and such other sanctions may be imposed and remedies invoked as provided in Executive Order 11246 of September 24, 1965, or by rule, regulation, or order of the Secretary of Labor, or as otherwise provided by law.
7. CONTRACTOR will include the portion of the sentence immediately preceding paragraph 1 and the provisions of paragraph 1 through 7 in every subcontract or purchase order unless exempted by rules, regulations, or orders of the Secretary of Labor issued pursuant to section 204 of Executive Order 11246 of September 24, 1965, so that such provisions will be binding upon each subcontractor or vendor. The CONTRACTOR will take such action with respect to any subcontract or purchase order as the administering agency may direct as a means of enforcing such provisions, including sanctions for noncompliance: provided, however, that in the event a CONTRACTOR becomes involved in, or is threatened with, litigation with a subcontractor or vendor as a result of such direction by the administering agency the CONTRACTOR may request the United States to enter into such litigation to protect the interest of the United States.

**B. DAVIS-BACON ACT (2 CFR §200.326 Appendix II to Part 200 (D))**

(Not applicable to this Contract; applicable only for prime construction contracts in excess of \$2,000.) CONTRACTOR shall pay wages to laborers and mechanics at a rate not less than those in the attached Davis-Bacon Act Wage Rate Table(s) as made by the Secretary of Labor. CONTRACTOR shall pay wages not less than once per week.

**C. COPELAND "ANTI-KICKBACK" ACT (2 CFR §200.326 Appendix II to Part 200 (D))**

(Not applicable to this Contract; applicable only for prime construction contracts in excess of \$2,000.) CONTRACTOR shall comply with the Copeland "Anti-Kickback" Act (40 U.S.C. §3145), as supplemented by Department of Labor regulations (29 CFR Part 3, "Contractors and Subcontractors on Public Building or Public Work Financed in Whole or in Part by Loans or Grants from the United States"). The Act provides that the CONTRACTOR and COUNTY is prohibited from inducing, by any means, any person employed in the construction, completion, or repair of public work, to give up any part of the compensation to which he or she is otherwise entitled. The COUNTY must report all suspected or reported violations to the appropriate Federal agency.

1. *CONTRACTOR. The CONTRACTOR shall comply with 18 U.S.C. § 874, 40 U.S. C. § 3145, and the requirements of 29 C.F.R. pt. 3 as may be applicable, which are incorporated by reference into this Contract.*
2. *Subcontracts. The CONTRACTOR or subcontractor shall insert in any subcontracts the clause above and such other clauses as the FEMA may by appropriate instructions require, and also a clause requiring the subcontractors to include these clauses in any lower tier subcontracts. The prime CONTRACTOR shall be responsible for the compliance by any subcontractor or lower tier subcontractor with all of these contract clauses.*
3. *Breach. A breach of the contract clause above may be grounds for termination of the Contract, and for debarment as a contractor and subcontractor as provided in 29 C.F.R. §5.12.*

**D. CONTRACT WORK HOURS AND SAFETY STANDARDS ACT (2 CFR §200.326 Appendix II to Part 200 (E)) (40 U.S.C. 3701-3708)**

(Not applicable to the purchases of supplies or materials or articles ordinarily available on the open market, or contracts for transportation or transmission of intelligence.) Contracts in excess of \$100,000 that involve the employment of mechanics or laborers shall comply with 40 U.S.C. 3702 and 3704, as supplemented by Department of Labor regulations (29 CFR Part 5). Under 40 U.S.C. 3702 of the Act, each CONTRACTOR and its subcontractors shall compute the wages of every mechanic and laborer on the basis of a standard workweek of 40 hours. Work in excess of the standard workweek is permissible provided that the worker is compensated at a rate of not less than one and a half times the basic rate of pay for all hours worked in excess of 40 hours in the workweek. The requirements of 40 U.S.C. 3704 are applicable to construction work and provide that no laborer or mechanic must be required to work in surroundings or under working conditions, which are unsanitary, hazardous or dangerous.

**E. RIGHTS TO INVENTIONS MADE UNDER A CONTRACT OR AGREEMENT (2 CFR §200.326 Appendix II to Part 200 (F))**

(Not applicable to this Contract.) If the Federal award meets the definition of "funding agreement" under 37 CFR §401.2 (a) and the recipient or subrecipient wishes to enter into a contract with a small business firm or nonprofit organization regarding the substitution of parties, assignment or performance of experimental, developmental, or research work under that "funding agreement," the recipient or subrecipient must comply with the requirements of 37 CFR Part 401, "Rights to Inventions Made by Nonprofit Organizations and Small Business." Firms under Government Grants, Contracts and Cooperative Agreements," and any implementing regulations issued by the awarding agency.

- F. CLEAN AIR ACT AND FEDERAL WATER POLLUTION CONTROL ACT (2 CFR §200.326 Appendix II to Part 200 (G))**  
CONTRACTOR shall comply with all applicable standards, orders or regulations issued pursuant to the Clean Air Act (42 U.S.C. 7401-7671q.) and the Federal Water Pollution Control Act as amended (33 U.S.C. 1251-1387). Violations must be reported to the Federal awarding agency and the Regional Office of the Environmental Protection Agency (EPA).
- G. DEBARMENT AND SUSPENSION (2 CFR §200.326 Appendix II to Part 200 (H))**  
A contract cannot be awarded to parties listed on the government-wide exclusions in the System for Award Management (SAM), in accordance with the OMB guidelines at 2 CFR 180 that implement Executive Orders 12549 (3 CFR part 1986 Comp., p. 189) and 12689 (3 CFR part 1989 Comp., p. 235), "Debarment and Suspension." The Excluded Parties List System in SAM contains the names of parties debarred, suspended, or otherwise excluded by agencies, as well as parties declared ineligible under statutory or regulatory authority other than Executive Order 12549. The Vendor/CONTRACTOR agrees to comply with the requirements of 2 C.F.R. pt. 180, subpart C and 2 C.F.R. pt. 3000, subpart C while this offer is valid and throughout the period of any contract that may arise from this offer. The Vendor/CONTRACTOR further agrees to include a provision requiring such compliance in its lower tier covered transactions.
- H. PROCUREMENT OF RECOVERED MATERIALS (2 CFR §200.322)**  
CONTRACTOR must comply with Section 6002 of the Solid Waste Disposal Act, as amended by the Resource Conservation and Recovery Act. The requirements of Section 6002 include procuring only items designated in guidelines of the Environmental Protection Agency (EPA) at 40 CFR part 247 that contain the highest percentage of recovered materials practicable, consistent with maintaining a satisfactory level of competition, where the purchase price of the item exceeds \$10,000 or the value of the quantity acquired by the preceding fiscal year exceeded \$10,000; procuring solid waste management services in a manner that maximizes energy and resource recovery; and establishing an affirmative procurement program for procurement of recovered materials identified in the EPA guidelines.
- I. CONTRACTING WITH SMALL AND MINORITY BUSINESSES, WOMEN'S BUSINESS ENTERPRISES, AND LABOR SURPLUS AREA FIRMS (2 CFR §200.321)**  
Should the CONTRACTOR subcontract any of the work under this Contract, CONTRACTOR shall take the following affirmative steps: place qualified small and minority businesses and women's business enterprises on solicitation lists; assure that small and minority businesses, and women's business enterprises are solicited whenever they are potential sources; divide total requirements, when economically feasible, into smaller tasks or quantities to permit maximum participation by small and minority businesses, and women's business enterprises; establish delivery schedules, where the requirement permits, which encourage participation by small and minority businesses, and women's business enterprises; and use the services and assistance, as appropriate, of such organizations as the Small Business Administration and the Minority Business Development Agency of the Department of Commerce. Their websites and contact information can be found at [www.SBA.gov](http://www.SBA.gov) and [www.MBDA.gov](http://www.MBDA.gov).
- J. ENERGY EFFICIENCY AND CONSERVATION**  
CONTRACTOR shall comply with the mandatory standards and policies of the Florida Energy Efficiency and Conservation Act issued in compliance with the Energy Policy and Conservation Act (42 U.S.C. § 6201).

## ***TERMINATION FOR DEFAULT***

The City of Mesquite reserves the right to enforce the performance of this contract in any manner prescribed by law or deemed to be in the best interest of the City in the event of breach or default of this contract. City of Mesquite reserves the right to terminate the **contract** immediately in the event the successful proposer fails to:

- ◆ meet delivery or completion schedules
- ◆ otherwise perform in accordance with the accepted proposal

Breach of contract or default authorizes the City to award to another proposer, purchase elsewhere, and charge the full increase in cost to the defaulting proposer.

## ***NON-PERFORMANCE CONDITION***

If the product or service is not in conformance with the specifications and requirements of the City, the vendor shall redo and complete any work necessary, bring the product or service into compliance at the vendor's expense.

CERTIFICATION REGARDING LOBBYING

The undersigned certifies, to the best of his or her knowledge and belief, that:

(1) No Federal appropriated funds have been paid or will be paid, by or on behalf of the undersigned, to any person for influencing or attempting to influence an officer or employee of any agency, a Member of Congress, an officer or employee of Congress, or an employee of a Member of Congress in connection with the awarding of any Federal grant, the making of any Federal loan, the entering into of any cooperative agreement, and the extension, continuation, renewal, amendment or modification of any Federal contract, grant, loan, or cooperative agreement.

(2) If any funds other than Federal appropriated funds have been paid or will be paid to any person for influencing or attempting to influence an officer or employee of any agency, a Member of Congress, an officer or employee of Congress, or an employee of a Member of Congress in connection with this Federal contract, grant, loan, or cooperative agreement, the undersigned shall complete and submit Standard Form-LLL, "Disclosure of Lobbying Activities," in accordance with its instructions.

(3) The undersigned shall require that the language of this certification be included in the award documents of all sub-awards at all tiers (including subcontracts, sub-grants, and contracts under grants, loans, and cooperative agreements) and that all subrecipients shall certify and disclose accordingly.

This certification is a material representation of fact upon which reliance was placed when this transaction was made or entered into. Submission of this certification is a prerequisite for making or entering into this transaction imposed by section 1352, title 31, United States Code. Any person who fails to file the required certification shall be subject to a civil penalty of not less than \$10,000 and not more than \$100,000 for each such failure.

Organization: \_\_\_\_\_

Street address: \_\_\_\_\_

City, State, Zip: \_\_\_\_\_

CERTIFIED BY:(type or print) \_\_\_\_\_

TITLE: \_\_\_\_\_

\_\_\_\_\_ **(signature)** **(date)**



**PUBLIC WORKS DEPARTMENT**

**BID RESPONSE**

**QUANTITIES FOR CAPITAL**

**REPAIR PROJECTS**

**Project: FD 4365-DR - FAIRHOPE DOCKS - BULKHEAD PA REPAIR PROJECT**

<b>"A DOCK" Type "A" Repairs - Deadman Pile Reset, Edge Dock &amp; Backfill</b>					
ITEM #	DESCRIPTION	UNIT	QTY	UNIT PRICE	ESTIMATE AMOUNT
1	Deadman Piles - Expose, Investigate, Reset and Adjust Tie Backs	LF	125		
2	New Edge Dock Servicing Covered - Reset/Repair Areas Undermined by Storm - PT SYP Construction per Detail - Unit Price includes all hardware, decking & substructure - pile capes, stringers, bracing, etc.	SF	250		
Project Sub-Total:					
3	Mobilization/Demobilization	LS	1		
Sub-Bid Total:					

<b>"B DOCK" Type "B" Repairs - Wood Bulkhead &amp; Boat Docks</b>					
ITEM #	DESCRIPTION	UNIT	QTY	UNIT PRICE	ESTIMATE AMOUNT
1	Bulkhead Piles - 12" x 20-24 Ft. Marine Grade Pressure Treated SYP - Mechanically Driven - Unit Price is in place and includes all equipment, labor, hardware and incidentals required for installation (Full Replacement)	Each	16		
2	Dead Man Piles - 12" x 16-24 Ft. Marine Grade Pressure Treated SYP - Mechanically Driven - Unit Price is in place and includes all equipment, labor, hardware and incidentals required for installation (66% Replacement)	Each	15		
3	Dock Piles - 12" x 16-24 Ft. Marine Grade Pressure Treated SYP - Mechanically Driven - Unit Price is in place and includes all equipment, labor, hardware and incidentals required for installation (Full Replacement)	Each	10		
4	New Bulkhead Wall - Double Course of 2x8x16 (12' minimum length) PT SYP Rough Cut - with triple 4x8 PT SYP RC Whalers, Per Detail - Mechanically Driven - Unit Price is in place and includes all equipment, labor, hardware and incidentals	LF	110		
5	New Dock Servicing "B Dock" - PT SYP Construction per Detail - Unit Price includes all hardware, decking & substructure - pile capes, stringers, bracing, etc.	SF	136		
Project Sub-Total:					
6	Mobilization/Demobilization	LS	1		
Sub-Bid Total:					



<b>"C DOCK" Type "C" Repairs - Total Bulkhead, Edge Dock &amp; Partial Pile Replacement</b>					
ITEM #	DESCRIPTION	UNIT	QTY	UNIT PRICE	ESTIMATE AMOUNT
1	Bulkhead Piles - 12" x 20-24 Ft. Marine Grade Pressure Treated SYP - Mechanically Driven - Unit Price is in place and includes all equipment, labor, hardware and incidentals required for installation (66% Replacement)	Each	33		
2	Dead Man Piles - 12" x 16-24 Ft. Marine Grade Pressure Treated SYP - Mechanically Driven - Unit Price is in place and includes all equipment, labor, hardware and incidentals required for installation (66% Replacement)	Each	33		
3	New Bulkhead Wall - Double Course of 2x8x16 (12' minimum length) PT SYP Rough Cut - with triple 4x8 PT SYP RC Whalers, Per Detail - Mechanically Driven - Unit Price is in place and includes all equipment, labor, hardware and incidentals required for installation	LF	300		
4	4-foot wide Finger Pier (3 Total) - PT SYP Construction per Detail - Unit Price includes all hardware, decking & substructure - pile capes, stringers, bracing, etc.	SF	540		
5	New Edge Dock Servicing Slips - (300 L.F. - 5 Feet Wide) PT SYP Construction per Detail - Unit Price includes all hardware, decking & substructure - pile capes, stringers, bracing, etc.	SF	1500		
Project Sub-Total:					
6	Mobilization/Demobilization	LS	1		
Sub-Bid Total:					

<b>PROJECT BID SUMMARY</b>		
ITEM #	DESCRIPTION	ESTIMATE AMOUNT
"A DOCK"	Type "A" Repairs - Deadman Pile Reset, Edge Dock & Backfill	
"B DOCK"	Type "B" Repairs - Wood Bulkhead & Boat Docks	
"C DOCK"	Type "C" Repairs - Total Bulkhead, Edge Dock & Partial Pile Replacement	
Combined Bid Total:		

WAIVER AND RELEASE OF LIEN  
(SAMPLE)

WHEREAS, the undersigned, \_\_\_\_\_

has furnished to \_\_\_\_\_  
the following:

\_\_\_\_\_ Services Furnished  
for use in the construction of a project belonging to \_\_\_\_\_

\_\_\_\_\_ Name of Borrower  
and designated as, \_\_\_\_\_,

NOW, THEREFORE, the undersigned, \_\_\_\_\_  
Subcontractor

for and in consideration of \$ \_\_\_\_\_

and other good valuable consideration, the receipt whereof is hereby acknowledged, do(es) hereby waive and release any and all liens, or right to or claim of lien, on the above described project and premises, under any law, common or statutory, on account of labor or materials, or both, heretofore or hereafter furnished by the undersigned to or for the account of said Name of Contractor \_\_\_\_\_ for said project.

Given under my (our) hand(s) and seal(s) this \_\_\_\_\_ day of \_\_, 20\_\_\_\_.

\_\_\_\_\_  
Name of Subcontractor

By \_\_\_\_\_  
President, Vice President, Partner or Owner, or, if signed by other than one of foregoing, accompanied by Power of Attorney signed by one of foregoing in favor of the Signer. (Use designation applicable)

CERTIFICATE OF CONTRACTOR (SAMPLE)

\_\_\_\_\_, certifies that he is the  
 \_\_\_\_\_ of \_\_\_\_\_,  
 Title of Office Name of Contractor  
 the Contractor, in a Construction Contract No. \_\_\_\_\_ dated  
 \_\_\_\_\_, 20\_\_\_\_, entered into between the  
 Contractor and \_\_\_\_\_,  
 the Owner, for the construction of a Project which bears the title  
 \_\_\_\_\_,

and that he is authorized to and does make this certificate on behalf of said Contractor in order to induce the Owner to make payment to the Contractor, in accordance with the provisions of the said construction contract.

Undersigned further says that all persons who have furnished labor in connection with said construction, have been paid in full; that the names of Subcontractors that furnished services in connection with such construction and the kind of services so furnished are:

NAME	KIND OF SERVICE
_____	_____
_____	_____
_____	_____
_____	_____

and that the Contractor has delivered to the Owner releases of liens executed by all such Subcontractors.

\_\_\_\_\_  
 Signature

#### 4-35 Supplemental General Clauses.

##### Pre-construction Conference:

The City will schedule a conference after Notice of Award with attendance required of the: Owner and Contractor.

The Agenda will be as follows:

1. Execution of Owner-Contractor Agreement.
2. Submission of executed bonds and insurance certificates.
3. Submission of list of Subcontractors, Schedule of Values, and Progress Schedule.
4. Designation of personnel representing the parties in Contract and the City.
5. Procedures and processing of field decisions, submittals, substitutions, applications for payments, proposal request, Change Orders and Contract closeout procedures.
6. Scheduling.

EXPERIENCE OF BIDDER:

Unless advised by the awarding authority in the Advertisement for Bids that the same is not required, the Bidder submits the following list of at least three clients for whom projects involving construction of similar projects have been performed within the past 5 years.

1.

Name of Client Telephone Number: \_\_\_\_\_

Street Address: \_\_\_\_\_

City / State: \_\_\_\_\_

Facility/Project Size: \_\_\_\_\_

Date of Project Completion: \_\_\_\_\_

Name of City of Record Telephone Number: \_\_\_\_\_

2.

Name of Client Telephone Number: \_\_\_\_\_

Street Address: \_\_\_\_\_

City / State: \_\_\_\_\_

Facility/Project Size: \_\_\_\_\_

Date of Project Completion: \_\_\_\_\_

Name of City of Record Telephone Number: \_\_\_\_\_

3.

Name of Client Telephone Number: \_\_\_\_\_

Street Address: \_\_\_\_\_

City / State: \_\_\_\_\_

Facility/Project Size: \_\_\_\_\_

Date of Completion: \_\_\_\_\_

Name of City of Record Telephone Number: \_\_\_\_\_

SECTION 6

BID BOND

The PRINCIPAL (Bidder's name and address)

The OWNER

City of Fairhope
P.O. Drawer 429
Fairhope, Al 36533

The PROJECT for which the Principal's Bid is submitted: (Project name as it appears in the Bid Documents)

Bid 005-21 Fairhope Docks Bulkhead Repairs - FEMA 4563

KNOW ALL MEN BY THESE PRESENTS, that we, the undersigned Principal and Surety, jointly and severally, hereby bind ourselves, our heirs, executors, administrators, successors, and assigns to the OWNER in the PENAL SUM of five percent (5%) of the amount of the Principal's bid, but in no event more than TEN THOUSAND DOLLARS (\$10,000.00).

THE CONDITION OF THIS OBIGATION is that the Principal has submitted to the OWNER the attached bid, which is incorporated herein by reference, for the Project identified above.

NOW, THEREFORE, if, within the terms of the Bid Document, the OWNER accepts the Principal's bid and the Principal thereafter either:

- (a) executes and delivers a Construction Contract with the required Performance and Payment Bonds (each in the for contained in the Bid Documents and properly completed in accordance with the bid) and delivers evidence of insurance as prescribed in the Bid Documents, or fails to execute and deliver such Construction Contract with such Bonds and evidence of insurance, but pays the OWNER the difference, not to exceed the Penal Sum of this Bond, between the amount of the Principal's Bid and the larger amount for which the OWNER may award a Construction Contract for the same Work to another Bidder, then, this obligation shall be null and void, otherwise it shall remain in full force and effect.

The Surety, for value received, hereby stipulates and agrees that the obligation of the Surety under this Bond shall not in any manner be impaired or affected by any extension of the time within which the OWNER may accept the Principal's bid, and the Surety does hereby waive notice of any such extension.

SIGNED AND SEALED this \_\_\_ day of \_\_\_, 20\_\_.

ATTEST
Principal (Company)
By

Print Name and Title

Surety Company

SURETY
ATTEST

By

Print Name and Title

**ITEM VI**  
**PERFORMANCE BOND**

KNOW ALL MEN: That we \_\_\_\_\_  
(Insert here the name & address of legal title of the Contractor)

hereinafter called the Principal, and \_\_\_\_\_  
(Insert here the name and address of legal title of one or more sureties)

And \_\_\_\_\_

hereinafter called the Surety or Sureties, are held and firmly bound unto the City of Fairhope hereinafter called the OWNER in the sum of \_\_\_\_\_ Dollars (\$ \_\_\_\_\_) for the payment whereof the Principal and the Surety or Sureties bind themselves, their heirs, executors, administrators, successors and assigns, jointly and severally, firmly, by these presents.

WHEREAS, the Principal has, by means of a written agreement, dated \_\_\_/\_\_\_/\_\_\_ entered into a Contract with the OWNER for: **Bid 005-21** which agreement is by reference made a part hereof,

NOW THEREFORE, The conditions of this obligation is such that if the Principal shall faithfully perform the Contract on his part, and satisfy all claims and demands, incurred for the same, and shall fully indemnify and save harmless the OWNER from all cost and damage which he may suffer by reason of failure to do so, and shall reimburse and repay the OWNER all outlay and expense which the OWNER may incur in making good for any such default thence this obligation shall be null and void; otherwise, it shall remain in full force and effect.

PROVIDED, HOWEVER, that no suit, action or proceedings, by reason of any default whatever be brought on his Bond after twelve months from the day on which the final payment under the Contract falls due.

PROVIDED, further, that the said surety or sureties, for value received hereby stipulate and agree that no change, extension of time, or addition to the terms of the Contract or to the work to be performed thereunder of the Specifications thereof shall in any way effect their obligations on this bond, and they do hereby waive notice of any such change, extension of time, alteration or addition to the terms of the contract, or to the work, or to the Specifications.

Witness our hands and seals this \_\_\_\_\_ day of \_\_\_\_\_, 20\_\_\_\_.

**INDIVIDUAL**

\_\_\_\_\_, Doing Business As, \_\_\_\_\_  
(Signature of Individual Bidder) (Business Name)

Business Mailing Address: \_\_\_\_\_  
\_\_\_\_\_  
email \_\_\_\_\_  
phone \_\_\_\_\_

**CORPORATION**

\_\_\_\_\_  
Name of Corporation, Partnership, or Joint Venture  
Business Mailing Address: \_\_\_\_\_  
\_\_\_\_\_  
email \_\_\_\_\_  
phone \_\_\_\_\_

BY: \_\_\_\_\_  
(Signature of Officer Authorized to sign Bids  
and Contracts for the Firm)

\_\_\_\_\_  
(Position or Title)

\_\_\_\_\_  
(General Contractor's License Number)

\_\_\_\_\_  
Foreign Corporation Entity Id (Required of out-of-state-vendors)

Attest:

\_\_\_\_\_  
(Secretary)

\_\_\_\_\_  
(Name of State under the laws of which incorporated)

\_\_\_\_\_  
(Name of Surety)

BY: \_\_\_\_\_  
(Attorney in Fact)



**ITEM VII**  
**LABOR AND MATERIALS BOND**

KNOW ALL MEN BY THESE PRESENTS, that we \_\_\_\_\_ As Principal, and \_\_\_\_\_ as Surety, are held and firmly bound unto said City of Fairhope hereinafter called the Obligee, in the penal sum of \_\_\_\_\_ Dollars (\$ \_\_\_\_\_) lawful money of the United States, for the payment of which sum and truly to be made, we bind ourselves, our heirs, personal representatives, successors and assigns, jointly and severally, firmly by these presents.

WHEREAS, said principal has entered into a certain Contract with said Obligee, dated \_\_\_/\_\_\_/20\_\_\_, (hereinafter called the Contract) for **Bid 005-21**, which Contract and the Specifications for said work shall be deemed a part hereof as fully as if set out herein.

NOW, THEREFORE, THE CONDITION OF THIS OBLIGATION IS SUCH THAT if the said Principal and all subcontractors to whom any portion of the work in said contract is sublet and all assignees of said Principal and of such subcontractors shall promptly make payments to all persons supplying him or them with labor, materials, or supplies for or in the prosecution of the work provided for in such Contract, or any amendment or extension of or addition to said Contract, and for the payment of reasonable attorney's fees incurred by the successful claimant or plaintiffs in suits or claims against the contractor arising out of or in connection with the said contract, then the above obligation shall be void; otherwise to remain in full force and effect.

PROVIDED, HOWEVER, that this bond is subject to the following conditions and limitations.

(a) Any person, firm or corporation that has furnished labor, materials, or supplies for or in the prosecution of the work provided for in said Contract shall have a direct right to action against the Principal and Surety on this bond, which right of action shall be asserted in a proceeding, instituted in the County in which the work provided for in said Contract is to be performed or in any County in which said Principal or Surety does business. Such right of action shall be asserted in a proceeding instituted in the name of the claimant or claimants for his or their use and benefit against the Principal and Surety or either of them (but not later than one year after the final settlement of said Contract falls due) in which action such claim or claims shall be adjusted and judgment rendered thereon.

(b) The Principal and Surety hereby designate and appoint the Mayor of the City of Fairhope or his successor or representative as the agent of each of them to receive and accept services of process or other pleading issued, or filed in any proceeding instituted on this bond and hereby consent that such service shall be the same as personal service on the Principal and/or Surety.

(c) The Surety shall not be liable hereunder for any damages or compensation recoverable under Workmen's Compensation or Employer's Liability Statute.

(d) In no event shall the Surety be liable for a greater sum than the penalty of this bond, or subject to any suit, action or proceeding thereon that is instituted later than one year after the final settlement of said contract.

(e) This Bond is given pursuant to the terms of an Act of the Legislature of the State of Alabama approved February 8, 1935, entitled: "An Act to further provide for Bonds and Contractors on State and other public works and suits thereon".

Witness our hands and seals this \_\_\_\_\_ day of \_\_\_\_\_, 20\_\_\_.

\_\_\_\_\_, Doing Business As, \_\_\_\_\_  
(Signature of Bidder) (Business Name)

Business Mailing Address:

Attest:

\_\_\_\_\_  
(Secretary)

\_\_\_\_\_  
(Name of State under the laws of which incorporated)

\_\_\_\_\_  
(Name of Surety)

BY: \_\_\_\_\_  
(Attorney in Fact)