

**CITY OF FAIRHOPE  
CITY COUNCIL WORK SESSION AGENDA**

**MONDAY, 22 FEBRUARY 2021 – 4:30 P.M. – COUNCIL CHAMBER**

1. Discussion for the FY 2021 Recreational Trails Program Grant
2. Committee Updates
3. Department Head Updates
4. Review of City Council Agenda

**Next Regular Meeting – March 8, 2021 - Same Time and Place**

**RESOLUTION NO. \_\_\_\_\_**

**AUTHORIZING THE SUBMISSION OF AN FY2021  
RECREATIONAL TRAILS PROGRAM GRANT APPLICATION TO THE  
ALABAMA DEPARTMENT OF ECONOMIC AND COMMUNITY AFFAIRS**

WHEREAS, the Alabama Department of Economic and Community Affairs (ADECA) is accepting grant applications for the FY 2021 Recreational Trails Program (RTP) grants; and

WHEREAS, the City of Fairhope has identified a need to construct a multi-use recreational trail, with trailhead facilities, for mountain biking and pedestrian use, located at the northern portion of the Triangle property, just north of Veterans Drive; and

WHEREAS, the total project cost estimate is \$550,000.00 and the City is requesting \$400,000.00 in FY 2021 RTP funds and, if the grant is funded, the City will provide \$150,000.00 (27%) in local matching funds through a cash contribution;

THEREFORE, BE IT RESOLVED BY THE City of Fairhope, IN REGULAR SESSION ASSEMBLED, that by this Resolution the City of Fairhope authorizes submission of a grant application to ADECA requesting an FY 2021 RTP grant and authorizes the Mayor to sign the required grant application documents on behalf of the City.

DULY ADOPTED THIS 22ND DAY OF FEBRUARY, 2021

\_\_\_\_\_  
Jack Burrell, Council President

Attest:

\_\_\_\_\_  
Lisa A. Hanks, MMC  
City Clerk

**Public Works Director Estimated Costs**

**ADECA - The Recreational Trails Program (RTP) - FY2021 FUNDING CYCLE**

**North Triangle Property - New Multi - Use Trails & Sidewalk Project**

Construction Estimate					
Construction of 7920 linear feet (1.5 Miles) of new 8 foot wide Multi-Use Trails, 1220 linear feet of new 6 foot concrete sidewalk, Trail Head Parking, Restrooms and Kiosk					
Item #	Description	Unit	Quantity	Unit Price	Amount
1	Clearing and Grubbing	LS	1	\$25,000.00	\$25,000.00
2	Unclassified Excavation	Yd <sup>3</sup>	940	\$6.00	\$5,640.00
3	Borrow Excavation (A-2-4(0) or A-4(0))	Yd <sup>3</sup>	470	\$12.00	\$5,640.00
4	Crushed Aggregate Base Course, Type A (825A), Plant Mixed, 6" Minimum Compacted Thickness - per SY	SY	7635	\$22.50	\$171,787.50
5	Steel Landscape Edging, hot-rolled, standard flexible carbon steel, Hot-Dipped Galvanized finish, fabricated in sections with stake pockets stamped, 3/16" x 6"	LF	15840	\$5.00	\$79,200.00
6	Concrete Sidewalk, 6-Foot, 3000 PSI, 4" thick (1220 linear feet total)	SY	813	\$26.25	\$21,341.25
7	8' Wooden Bridge Boardwalk (Including all timber, galvanized hardware, anchors and Paint) (509D-000)	LF	120	\$225.00	\$27,000.00
8	Mobilization (600A-000)	LS	1	\$25,000.00	\$25,000.00
9	24" RCP Side Drain (Driveway Culvert)	LF	32	\$65.00	\$2,080.00
10	Slope Concrete Paving (6" HC Parking Apron)	Yd <sup>3</sup>	43	\$45.25	\$1,945.75
11	Sloped Paved Headwalls	Each	2	\$750.00	\$1,500.00
12	Concrete Ribbon Curb - 6" Wide	LF	185	\$15.00	\$2,775.00
13	Asphalt wearing surface - 429A 165 #/sy - 1.5" thick - Driveway - Unit Price includes subbase, base processing and paving	Yd <sup>3</sup>	160	\$62.86	\$10,057.60
14	Bathroom - Men/Women - one W.C. & Lavatory per side - 6 foot covered porch, CMU on slab with wood framed roof structure (Turn Key Price)	Each	1	\$75,000.00	\$75,000.00
15	Trail Head Kiosk and Bicycle Repair Station (Turn Key Price)	Each	1	\$12,500.00	\$12,500.00
16	Topsoil, 4" Compacted Thickness (650A-000)	Yd <sup>3</sup>	82	\$15.25	\$1,250.50
17	Seeding (652A-100)	Acre	0.5	\$750.00	\$375.00
18	Solid Sodding (Centipede) (654A-003)	Yd <sup>2</sup>	1101	\$6.50	\$7,156.50
19	Mulching (656A-010)	Acre	0.5	\$900.00	\$450.00
20	Erosion Control Measures (BMP's)	LS	1	\$12,500.00	\$12,500.00
21	Traffic Control Markings, Class 2, Type A (703A-002)	Ft <sup>2</sup>	144	\$12.50	\$1,800.00
22	Project Contingencies	Each	1	\$10,000.00	\$10,000.00
<b>Estimated Construction Cost</b>					<b>\$499,999.10</b>

Professional Services Calculations					
Item #	Description	Unit	Quantity	Unit Price	Amount
1	Engineering Survey & Design (5.0% of Construction)	Each	1	\$24,999.96	\$24,999.96
2	Material Testing (1.0% of Construction)	Each	1	\$4,999.99	\$4,999.99
3	Engineering - CE&I (4.0% of Construction)	Each	1	\$19,999.96	\$19,999.96
<b>Estimated Professional Service Cost</b>					<b>\$49,999.91</b>

<b>Estimated Total Cost (Including Engineering, Survey, Design, Material Testing and CE&amp;I)</b>					<b>\$549,999.01</b>
--	--	--	--	--	---------------------



**Recreational Trails Grant - North Triangle Property - Overall Trail Layout**

Prepared By:	R.D. Johnson, PE	City of Fairhope
Date:	2/9/2021	Scale: N.T.S.
Project No.:	2021-PWI 008	BOUNDARY

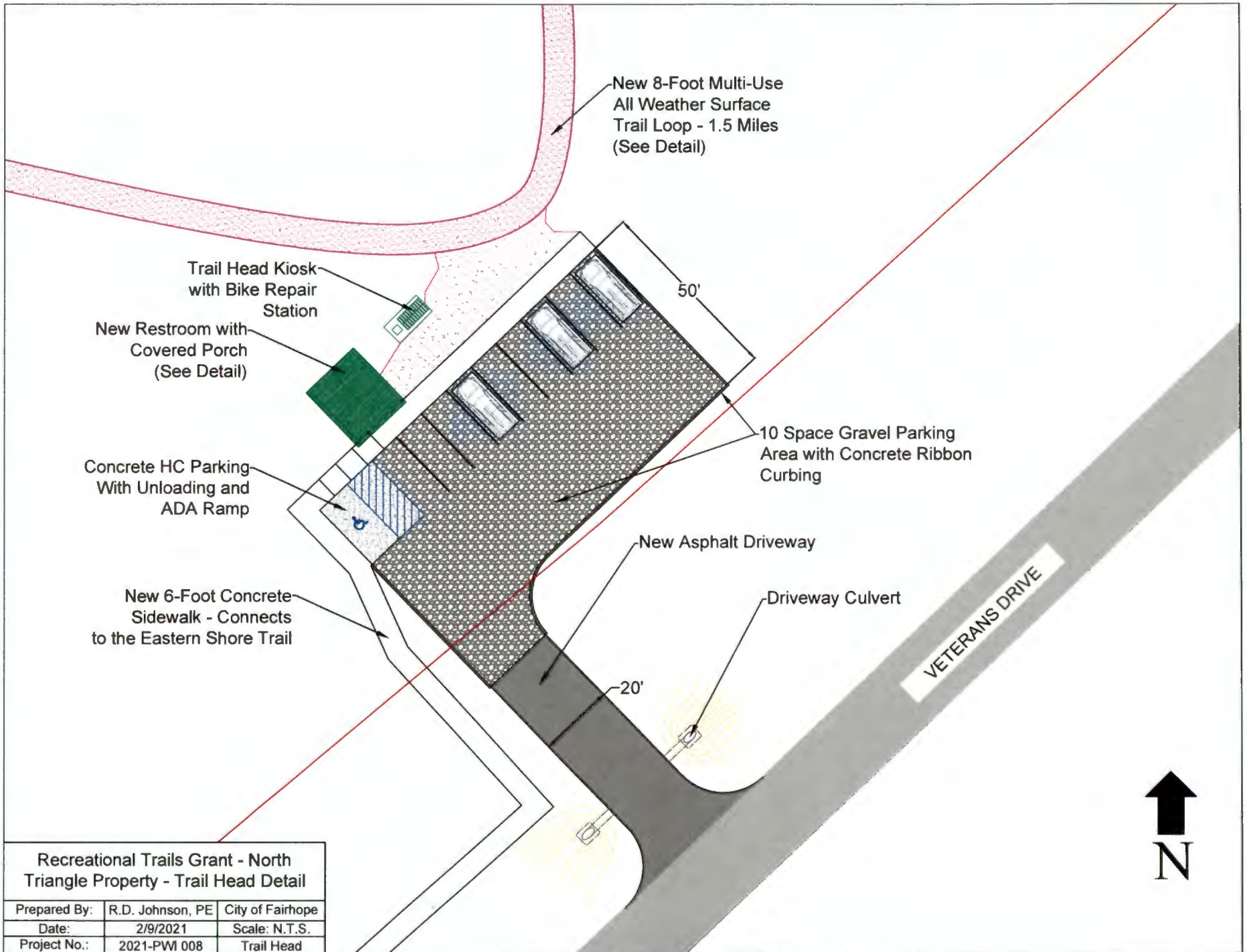

<b>Recreational Trails Grant - North Triangle Property - Trail Head Detail</b>		
Prepared By:	R.D. Johnson, PE	City of Fairhope
Date:	2/9/2021	Scale: N.T.S.
Project No.:	2021-PWI 008	Trail Head

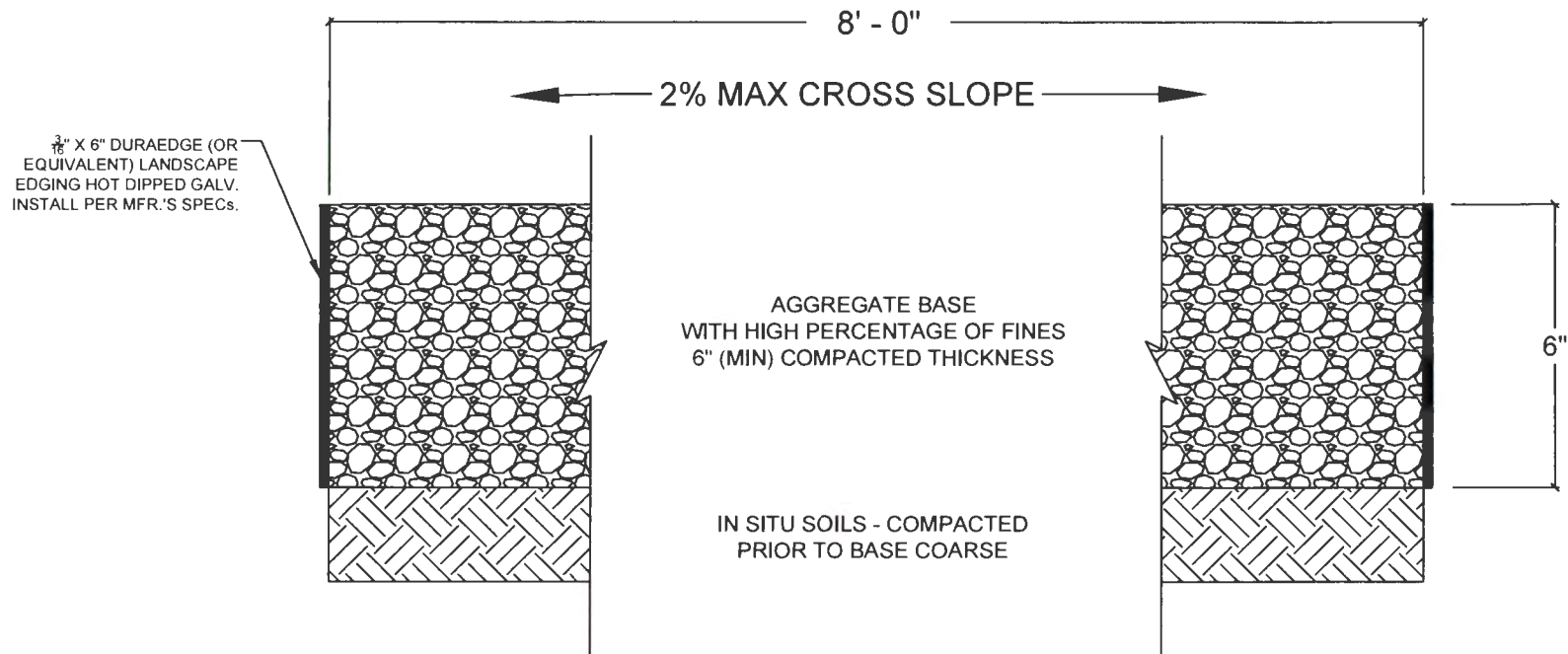

### COMPACTED AGGREGATE TRAIL TYPICAL CROSS SECTION

#### SPECIAL SPECIFICATIONS - COMPACTED AGGREGATE TRAILS

1. DESCRIPTION. Furnish and install aggregate trails and as shown on the plans or as directed.
2. MATERIALS. Provide aggregate base material, necessary subgrade fill material, weed barrier fabric, binding material, and other miscellaneous items as shown on the plans.
3. COLOR. Aggregate Material Color shall be selected by the owner based on aesthetics, price and/or availability.
4. CONSTRUCTION. All materials furnished will be installed as shown on the plans or as directed by the Engineer.
5. Aggregate Base. Place over filter fabric. Remove loose material from the exposed subgrade. Place aggregate in maximum 3 in. deep lifts, wet thoroughly, and let set according to the supplier's instructions.
6. Compact to not less than 90% nor more than 95% of maximum dry density (ASTM D 698) with a roller. Do not use a tamp plate.
7. MEASUREMENT. This item will be measured by Square Yard, complete in place for the project, as shown on the plans.
8. PAYMENT. The work performed and materials furnished in accordance with this item and as provided under "Measurement" will be paid for at the unit price bid of Square Yard for "Aggregate Base". This price is full compensation for furnishing, installing, testing, and for all other materials, labor, tools, equipment, and incidentals.
9. STABILIZER. Aggregate Trail will be installed using TerraKoat EX Stabilizer and Top Coat (or equivalent) - stabilizers shall be used per the manufacturer's directions and application rates. The stabilizers shall be a subsidiary obligation of the Aggregate Base Unit Cost.
10. EDGING. Landscape Edging shall be DuraEdge (or equivalent)  $\frac{3}{8}$ " thick, 6" wide, by 16' length, with 6 stakes (actual coverage 15'-4"), Hot Dipped Galvanized, Comply with ASTM A 569, hot rolled, standard flexible steel.

#### Recreational Trails Grant - North Triangle - Aggregate Trail Details

Prepared By:	R.D. Johnson, PE	City of Fairhope
Date:	2/10/2021	Scale: N.T.S.
Project No.:	2021-PWI 008	Sheet: 3 of 4

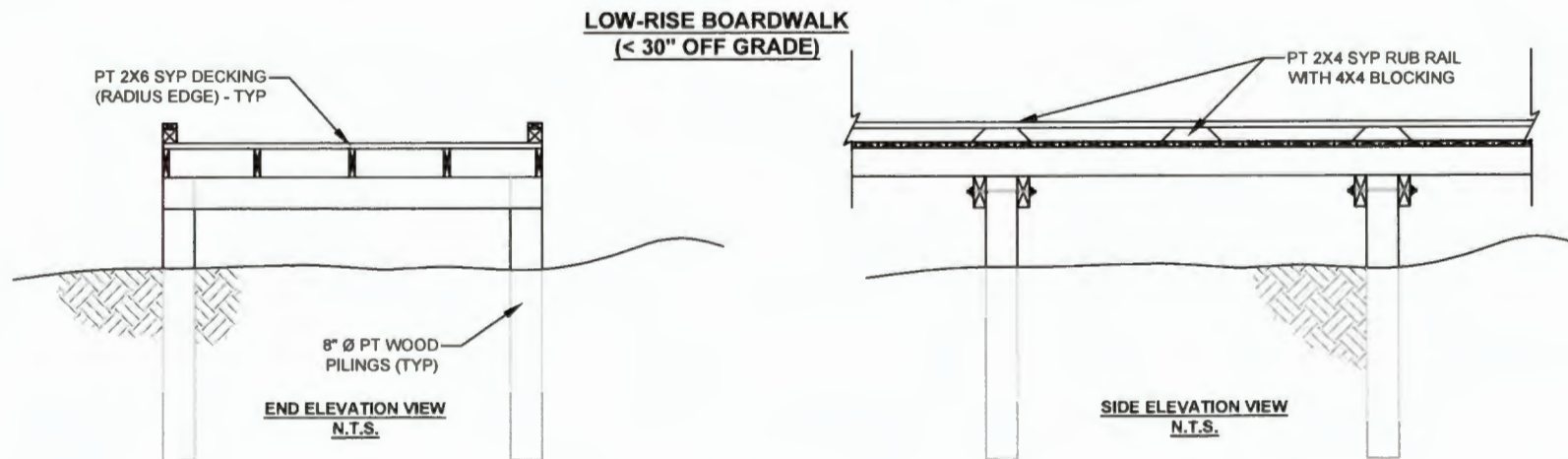
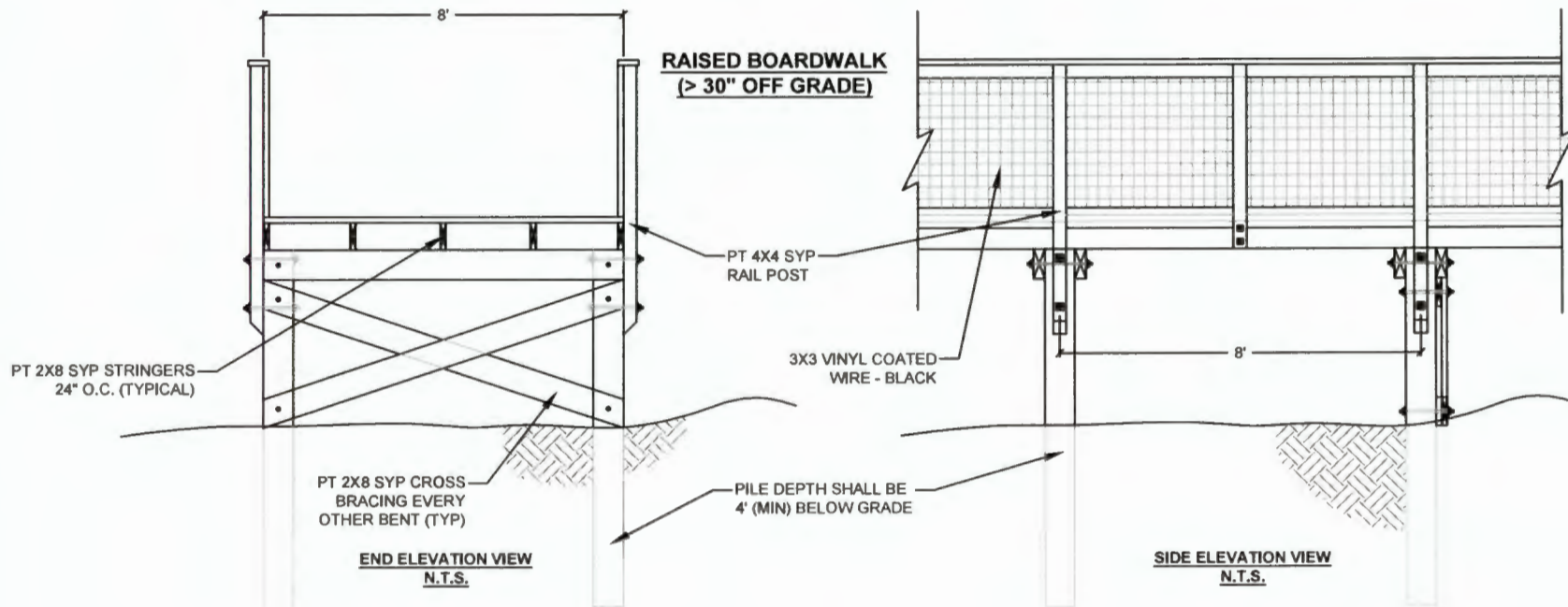

**NOTES:**

1. Boardwalks shall be used in strategic locations to cross drainage ways and other features to allow for their natural function without interference.
2. Boardwalks shall be built with approach and departure ramps that tie into the Decomposed Granite Trails. All boardwalks shall be in full compliance with the Americans With Disabilities Act (ADA).
3. All sections of Boardwalks more than 30' above finished grade shall have handrails as shown, those sections less than 30' off finished grade shall be built with rub rails as shown.

**Recreational Trails Grant - North  
Triangle - Trail Boardwalk Details**

Prepared By:	R.D. Johnson, PE	City of Fairhope
Date:	2/10/2021	Scale: N.T.S.
Project No.:	2021-PWI 008	Sheet: 4 of 4



RTP Bathroom at Trail Head  
Conceptual Drawing



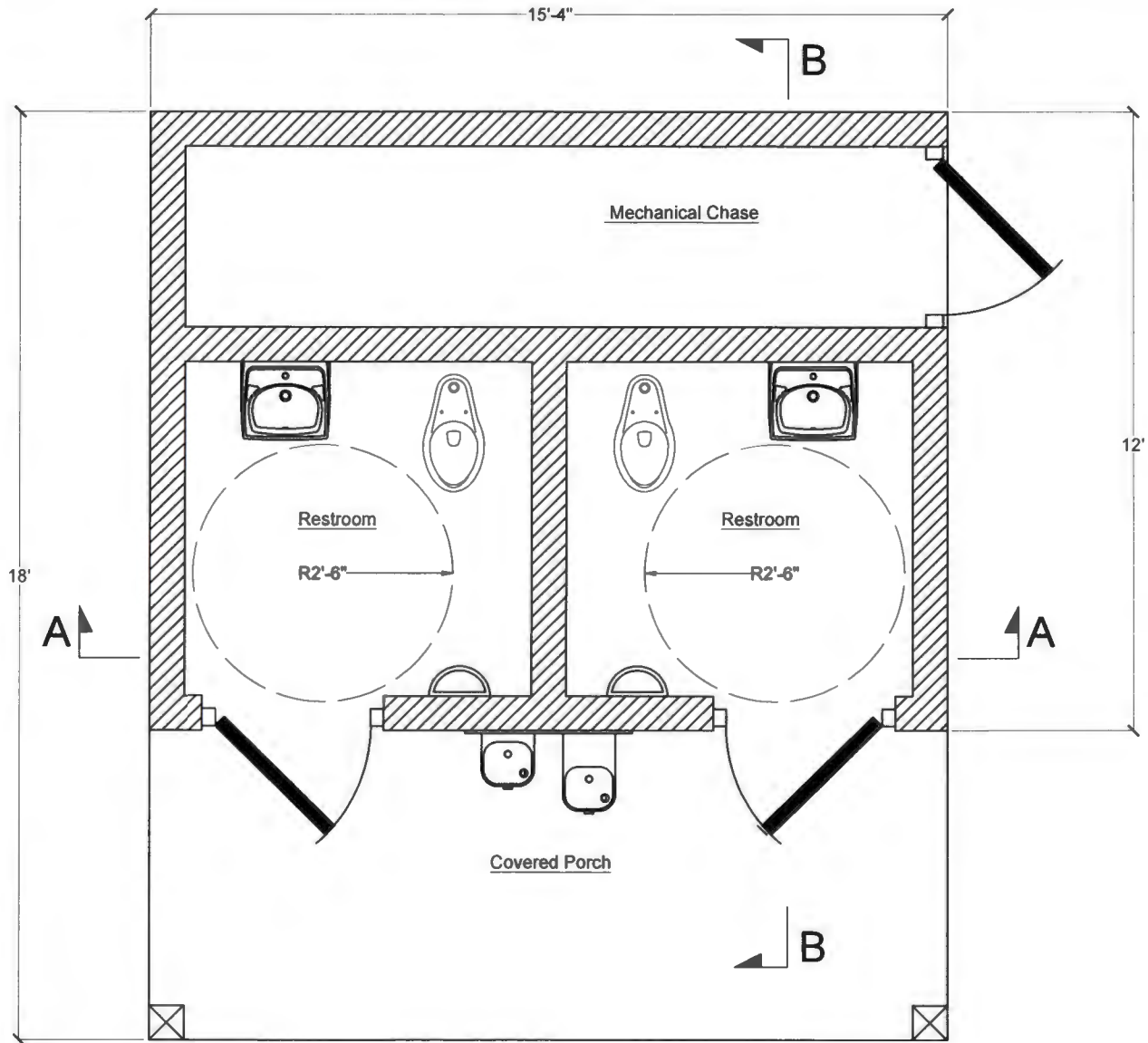

**PLAN VIEW**  
**Grant Application Conceptual Drawing**

**RTP Grant North Triangle - Trailhead Restroom**

City of Daphne - Public Works Department

Dwg: RDJ

Date:02/09/2021

Sheet #: 1 of 3

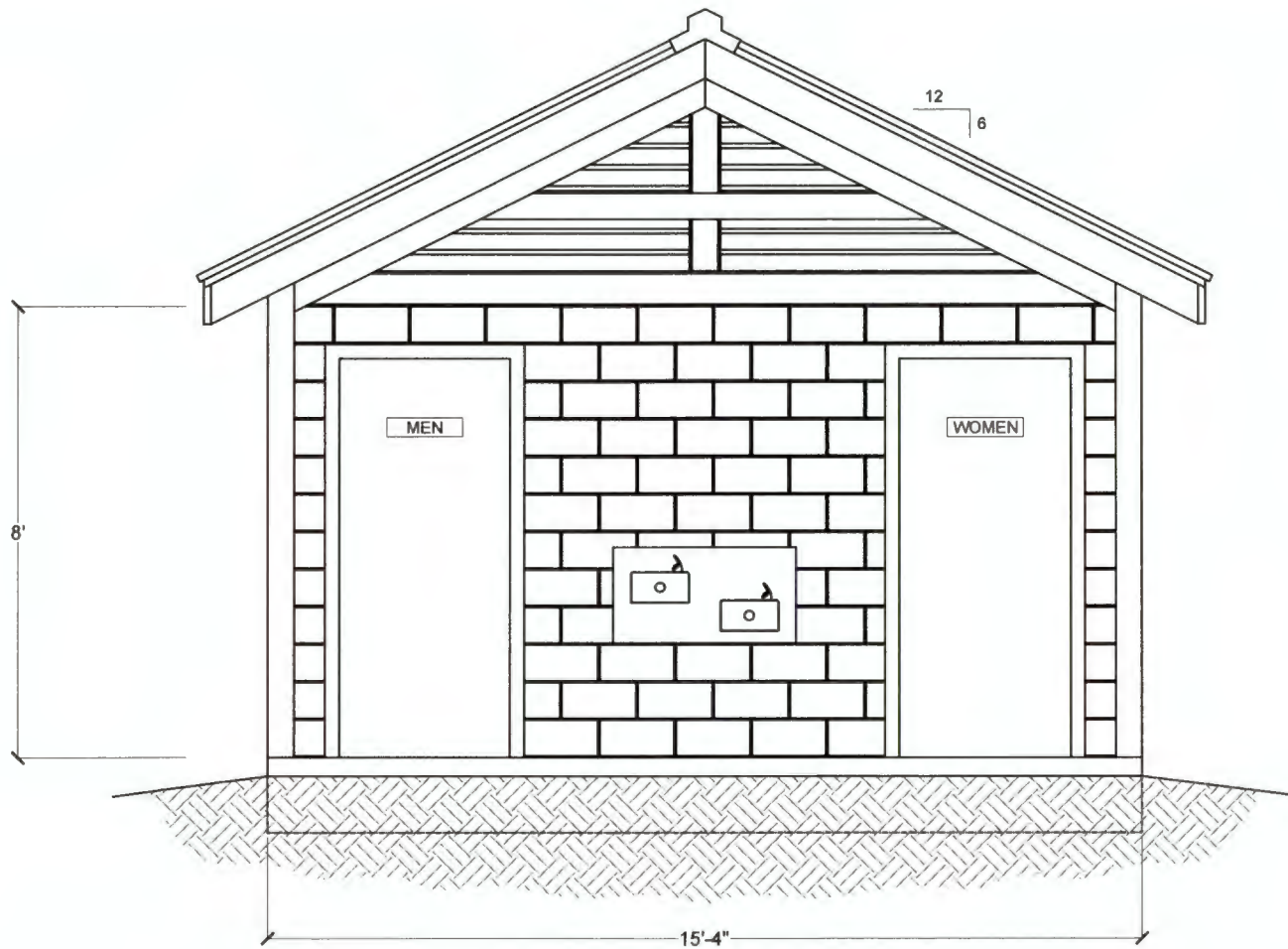

**FRONT ELEVATION VIEW**  
**Grant Application Conceptual Drawing**

<b>RTP Grant North Triangle - Trailhead Restroom</b>		
City of Daphne - Public Works Department		
Dwg: RDJ	Date:02/09/2021	Sheet #: 2 of 3

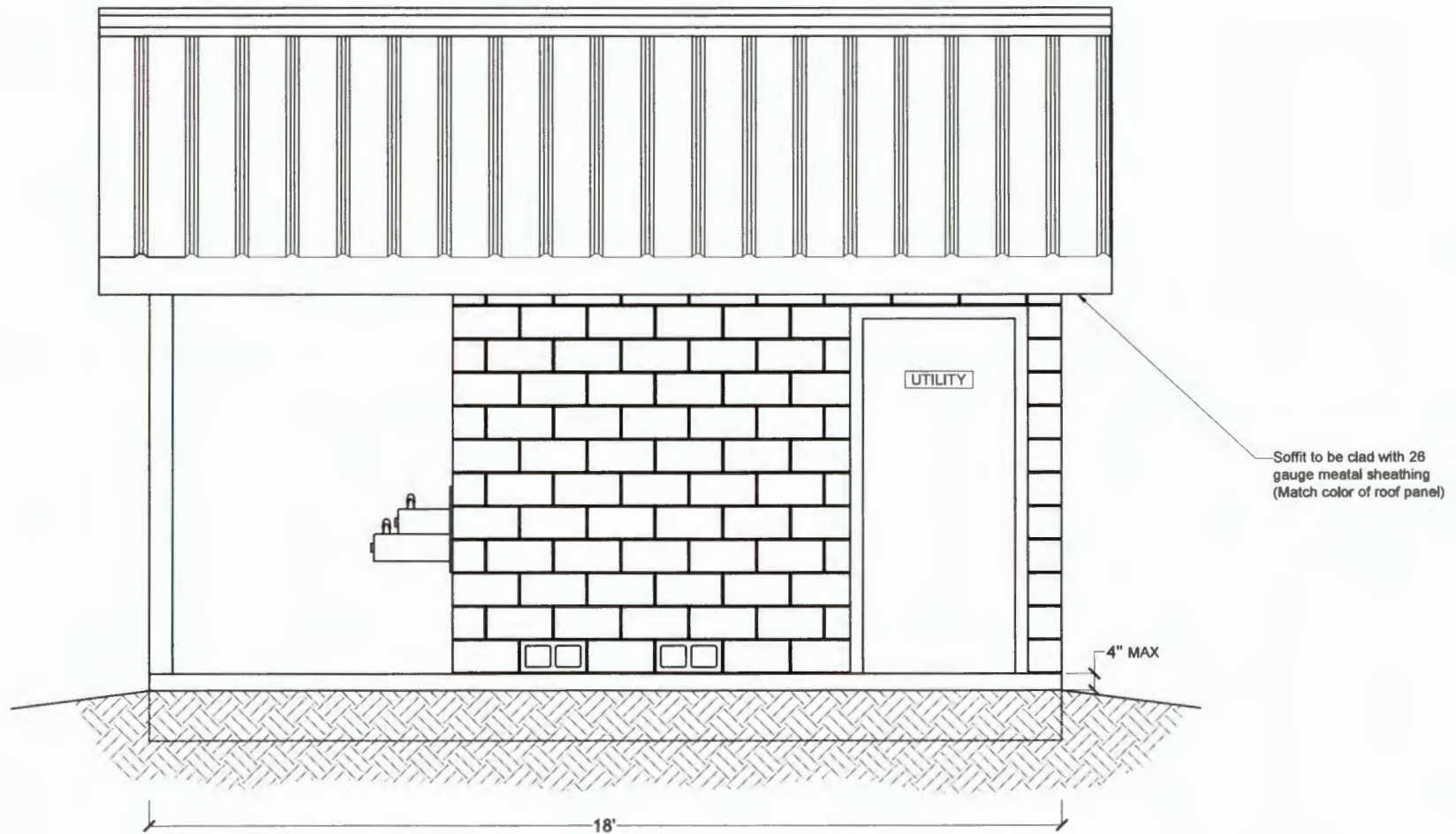

**SIDE ELEVATION VIEW (MECHANICAL ACCESS SIDE)**  
 Grant Application Conceptual Drawing

<b>RTP Grant North Triangle - Trailhead Restroom</b>		
City of Daphne - Public Works Department		
Dwg: RDJ	Date: 02/09/2021	Sheet #: 3 of 3

# KIOSK SCALED DRAWING

Jan. 5, 2009

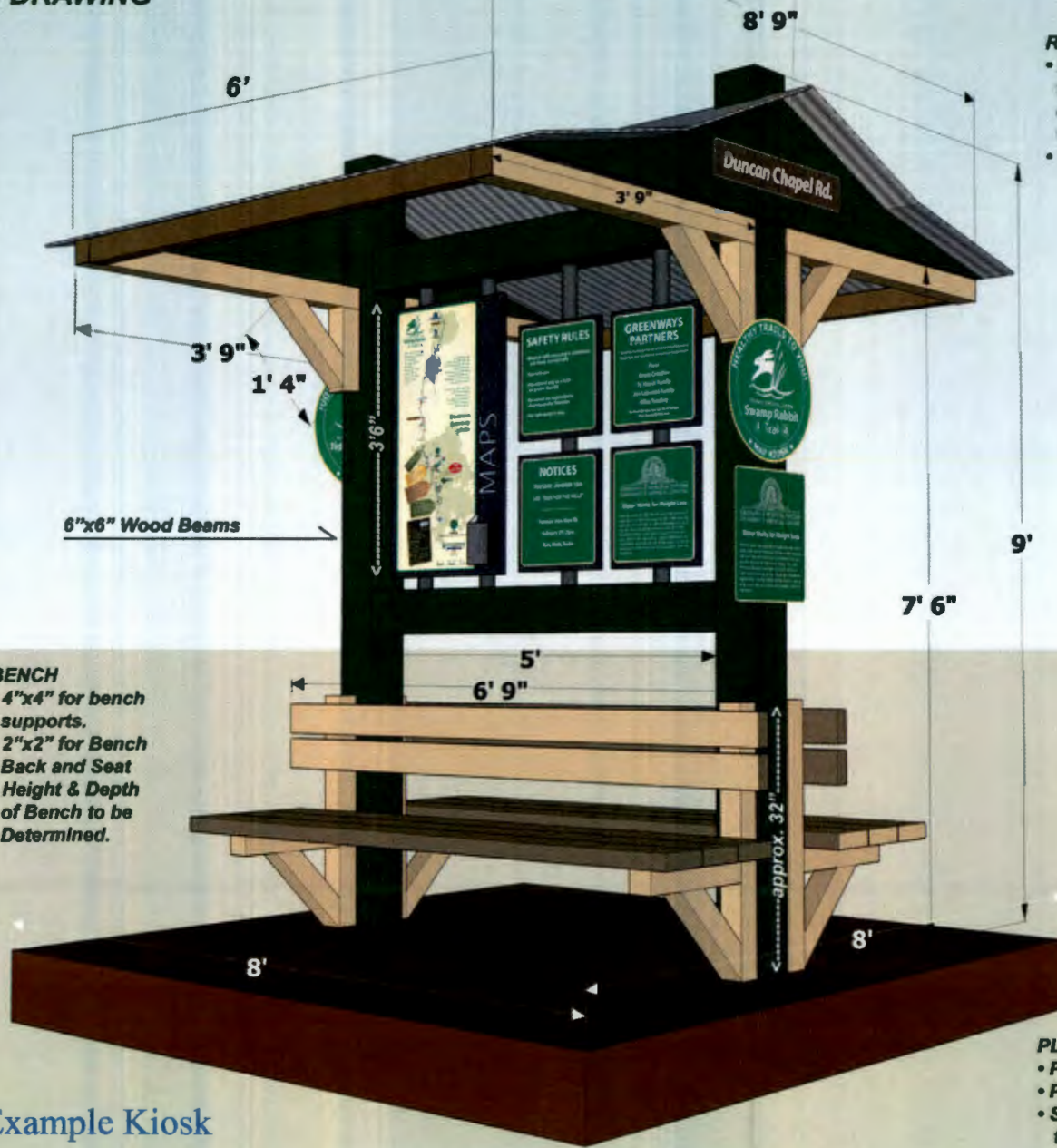

### ROOF:

- Main support beam will extend through roof to give appearance of historic train stations with chimneys.
- Tin Roof



### BENCH

- 4"x4" for bench supports.
- 2"x2" for Bench Back and Seat
- Height & Depth of Bench to be Determined.

### PLATFORM:

- Platform Height 6"-12" inches
- Platform Dimensions 8'x8'
- Slatted wood to allow debris to drop through.

Conceptual Example Kiosk



Patents D680,914 S1 and 9,498,880 B2

## Fixit

The Fixit includes all the tools necessary to perform basic bike repairs and maintenance, from changing a flat to adjusting brakes and derailleurs. The tools are securely attached to the stand with stainless steel cables and tamper-proof fasteners. Hanging the bike from the hanger arms allows the pedals and wheels to spin freely while making adjustments.

Hanger arms accommodate most types of bikes

QR code takes smart phone users to comprehensive bike repair web site

Large surface area for sponsorship, branding, or way-finding signage

Tools are secured with braided stainless steel aircraft cables

Screwdrivers and Allen Wrenches are on swivel connectors for easier use

Includes most commonly used tools for simple bike maintenance

Tamper-resistant fasteners included!

**Tools included:**

- Philips and flat head screwdrivers
- 2.5, 3, 4, 5, 6, 8mm Allen wrenches
- Headset wrench
- Pedal wrench
- 8, 9, 10, 11mm box wrenches
- Tire levers (2)

Add your choice of an Air Kit bike pump (sold separately) to keep your cyclists' tires topped up and ready to roll. The Air Kits feature our new Metal Head™, a sturdy cast aluminum pump head with Presta and Schrader valve compatibility.

*These public bike repair products require occasional maintenance and replacing of parts to remain serviceable.*

## FINISH OPTIONS

### Galvanized



### Stainless



### Powder Coat

White	Black	Light Gray RAL 7042	Deep Red RAL 3003	Yellow RAL 1023
CNH Bright Yellow	Orange RAL 2004	Beige RAL 1001	Iron Gray RAL 7011	Hunter Green RAL 6005
Light Green RAL 6018	Green RAL 6016	Sepia Brown RAL 8014	Bronze	Silver RAL 9007
Dark Purple	Flat Black	Wine Red RAL 3005		

**CITY OF FAIRHOPE  
CITY COUNCIL AGENDA**

**MONDAY, 22 FEBRUARY 2021 - 6:00 P.M. - CITY COUNCIL CHAMBER**

**Invocation and Pledge of Allegiance**

1. Approve minutes of 8 February 2021 Regular City Council Meeting, minutes of 8 February 2021 Work Session, and minutes of 8 February 2021 Agenda Meeting.
2. Report of the Mayor
3. Police Department – Presentation of Awards
4. Public Participation – Agenda Items – (3 minutes maximum)
5. Council Comments
6. **Final Adoption** – Ordinance – Amend Zoning Ordinance No. 1253.  
Zoning Ordinance Amendment
  - Article V, Adding HTD – Highway Transitional District; Article III. Section B. Table 3-1: Use Table adding column for HTD permitted uses; and Article III, Section B. Table 3-2: Dimension Table adding row for HTD. (Introduced at the February 8, 2021 City Council Meeting)
7. **Final Adoption** – Ordinance – Amend Zoning Ordinance No. 1253.  
Request to rezone the property of Seaman Capital, LLC/Dominion Partners from R-1 Low Density Single Family Residential District to Planned Unit Development (PUD). The property generally located at southwest of the intersection of Greeno Road and Volanta Avenue, Fairhope, Alabama. PPIN Numbers: 386193 and 386197. The property to be known as The Reserve at Fairhope PUD. (Introduced at the February 8, 2021 City Council Meeting)
8. **Final Adoption** – An Ordinance amending Ordinance No. 1312 (Section 16); and to repeal and replace Ordinance No. 1468, known as the Towing and Recovery Rotation Ordinance. This is Section 22-56 in the City of Fairhope’s Code of Ordinances.
9. Ordinance – An Ordinance to amend Ordinance No. 1266 and to repeal and replace Ordinance No. 1608. Fairhope Code of Ordinances: Article VI, Garbage and Trash Collection and Disposal, Section 21-75: Rates.
10. Resolution – That the City of Fairhope rescinds the award of RFP PS007-20, Resolution No. 3926-20, upon the request of ADCNR for the purpose of rescoring the proposals due to a discrepancy in the rating criteria; and to utilize the revised rating criteria as outlined in the RFP and approved by ADCNR.
11. Resolution – That the City Council approves the selection of Hope Hicks with Ball, Ball, Matthews & Novak for HR related Consulting Services; and hereby authorizes Mayor Sherry Sullivan to execute the associated contract/engagement letter for an additional \$5,000.00, bringing the total with a not-to-exceed to \$10,000.00.

12. Resolution – That the City of Fairhope authorizes submission of an application to ADECA requesting an FY 2021 Recreational Trails Program (“RTP”) grant and authorizes Mayor Sherry Sullivan to sign the required grant application on behalf of the City to construct a multi-use recreational trail, with trailhead facilities, for mountain biking and pedestrian use, located at the northern portion of the Triangle property, just north of Veterans Drive. Total projected costs estimate is \$500,000.00 (City will provide an estimated \$150,000.00 which is 27% if funded).
13. Resolution – Authorizing Mayor Sherry Sullivan to execute a Contract between the City of Fairhope and Baldwin County Economic Development Alliance for an appropriation of \$15,000.00 to support economic development facilitation within the City of Fairhope.
14. Resolution – Authorizing Mayor Sherry Sullivan to execute a Contract between the City of Fairhope and Care House, Inc. for an appropriation of \$5,000.00 to help with continuing support for children who are victims of sexual and severe physical abuse; and to help with the distribution of the child abuse prevention curriculum.
15. Resolution – Authorizing Mayor Sherry Sullivan to execute a Contract between the City of Fairhope and the Downtown Fairhope Business Association for an appropriation of \$20,000.00 to advertise and promote the City of Fairhope.
16. Resolution – Authorizing Mayor Sherry Sullivan to execute a Contract with the Eastern Shore Art Center for use of City Facilities and for an appropriation of \$20,000.00 for funds to support and sponsor the educational programs through The Art Center’s Academy of Fine Arts.
17. Resolution – Authorizing Mayor Sherry Sullivan to execute a Contract between the City of Fairhope and the Eastern Shore Chamber of Commerce for an appropriation of \$21,000.00 (which includes \$15,000.00 for the Annual Leaders Council Program) to advertise and promote the City of Fairhope.
18. Resolution – Authorizing Mayor Sherry Sullivan to execute a Contract between the City of Fairhope and the Baldwin Pops for an appropriation of \$2,000.00, in-kind services in the amount of \$8,400.00, and resources including personnel, but not security after normal business hours; and provides an exception to the Sign Ordinance by allowing banners for their Citywide events and to be displayed 10 days prior to those events to advertise and promote the City of Fairhope; and to provide free concerts yearly for the residents of Fairhope.
19. Resolution – Authorizing Mayor Sherry Sullivan to execute a Contract between the City of Fairhope and Ecumenical Ministries Incorporated for an appropriation of \$10,000.00 to support the needs of Fairhope residents.
20. Resolution – Authorizing Mayor Sherry Sullivan to execute a Contract between the City of Fairhope and The Fairhope Film Festival for an appropriation of \$6,000.00 to help bring sustained economic growth from the film industry to the Alabama Gulf Coast through its Fairhope Film Festival.



21. Resolution – Authorizing Mayor Sherry Sullivan to execute a Contract between the City of Fairhope and Mobile Bay National Estuary Program for an appropriation of \$15,000.00 to support activities related to Stormwater education and watershed management.
22. Resolution – Authorizing Mayor Sherry Sullivan to execute a Contract between the City of Fairhope and the Fairhope Pirate Booster Club, Inc. for an appropriation of \$10,000.00 to assist in the purchase of three Clorox Total360 disinfectant sprayers to be placed in the Girl’s Fieldhouse, Men’s Fieldhouse, and locker rooms to disinfect the site and equipment; and to approve the use of the Fairhope Civic Center for the Annual Drawdown and Silent Auction (date to be announced) which includes the use of associated rooms as needed, placement of a tent in the parking lot (all rental expenses paid by the Club), and use of the facility’s tables and chairs in the tent.
23. Resolution – Authorizing Mayor Sherry Sullivan to execute a Contract between the City of Fairhope and the Fairhope -Point Clear Rotary Youth Club for an appropriation of \$57,000.00 to help manage and operate the Fairhope-Point Clear Rotary Youth Club facility which includes cleaning supplies.
24. Resolution – Authorizing Mayor Sherry Sullivan to execute a Contract between the City of Fairhope and the Fairhope Educational Enrichment Foundation, Inc. for an appropriation of \$50,000.00 to help with the FEEF STEAM Center to be located at the K-1 Center.
25. Resolution – To Reject all Bids for Municipal Pier Utility Tray Repairs Rebid for the Public Works Department (Bid No. 012-21) pursuant to the Code of Alabama 1975, Section 41-16-57-2(d); and reevaluate project scope.
26. Resolution – That Mayor Sherry Sullivan is hereby authorized to execute a contract for Extension No. 1 of Bid No. 016-20, Sludge Removal Services 2020 for the Sewer Department, with GreenSouth Solutions, LLC for an additional one year, as per the terms and conditions of the original contract. The total bid proposal of \$85.00 per cubic yard, for an estimated annual cost of \$550,000.00.
27. Resolution – That the City of Fairhope approves the procurement for Fly Creek Tree Removal caused by Hurricane Sally (FEMA 4563). The RFQ was sent to forty (40) contractors as well as multiple State agencies for MBE and DEB consideration. The City received five responsive and responsible quotes; and awards the project to Tonsmeire Construction, Inc. in the amount of \$24,602.50.
28. Resolution – That the City of Fairhope approves the procurement for Wooden Pier Repairs damaged by Hurricane Sally (FEMA 4563). RFQ 2021-PWI 006 was sent to twenty-five (25) contractors as well as multiple State agencies for MBE and DEB consideration. The City received two responsive and responsible submissions; and awards the project to Asphalt Services, Inc. in the amount of \$60,119.00. An insurance claim has been filed; and once the claim is done, then FEMA claim will be submitted.
29. Resolution – That the City of Fairhope has voted to purchase a 2021 Dodge Ram 2500 3/4 Ton Crew Cab 4x4 Pickup Truck for the Gas Department; and the type of vehicle needed is on the Alabama State Department of Purchasing bid list and therefore does not have to be let out for bid. The cost will be \$28,208.30.

30. Resolution – That the City of Fairhope has voted to purchase a 2021 Dodge Ram 5500 Diesel Crew Cab and Chassis with dual rear wheels for the Gas Department; and the type of vehicle needed is on the Alabama State Department of Purchasing bid list and therefore does not have to be let out for bid. The cost will be \$50,172.00.
31. Resolution – That the City of Fairhope has voted to purchase a 2021 Utility Body for Dodge Ram 5500 Diesel Crew Cab for the Gas Department; and the type of vehicle needed is on the Alabama State Department of Purchasing bid list and therefore does not have to be let out for bid. The cost will be \$22,371.00.
32. Resolution – That the City of Fairhope has voted to procure a 2021 Caterpillar 303.5 E2 CR-Canopy Mini Excavator with Power Angle for the Water and Sewer Departments; and the item is available for direct procurement through the Sourcewell Contract; and therefore, does not have to be let out for bid. This has been nationally bid through the OMNIA Partners' bid process. The total cost will be \$44,980.00.
33. Resolution – That the City of Fairhope has voted to procure a 2021 Caterpillar 303.5 E2 CR-Canopy Mini Excavator with Power Angle through Sourcewell Contract and Econoline LP0721ITE Trailer through Omnia Partners Contract for the Gas Department; and the items are available for direct procurement through these Contracts. These items have been nationally bid through their bid process; and therefore, do not have to be let out for bid. The total cost will be \$49,996.00.
34. Resolution – That the City of Fairhope has voted to procure a 2021 Petersen Lightning Loader Trash Truck with Dump Body for the Sanitation Department (Public Works); and the item is available for direct procurement through the Sourcewell Contract which has been nationally bid through their bid process; and therefore, does not have to be let out for bid. The total cost will be \$157,134.38.
35. Resolution – That the City of Fairhope approves the procurement for Fairhope Fire Hall Roof damaged by Hurricane Sally (FEMA 4563). This Request for Quotes was sent to eight (8) contractors as well as multiple State agencies for MBE and DEB consideration. The initial request received no quotes, so the City solicited quotes a second time and received one quote; and awards the project to Roof Doctors of Alabama in the amount of \$10,500.00. An insurance claim has been filed; and once the claim is done, then FEMA claim will be submitted.
36. Resolution – That City of Fairhope hereby terminates the Purchase Order (the Contract) between the City of Fairhope and CDW Government, LLC, for the procurement of an IT Consultant for 3-Year Services Contract, due to no compromise could be reached by the attorneys for CDW and City of Fairhope.
37. Resolution – That the City of Fairhope has voted to purchase a 2013 Dodge Ram Flat Crew Cab Dump Truck for the Water Department and the type of vehicle needed is on the Alabama Department of Transportation (ALDOT) surplus equipment list. The total cost not to exceed \$22,957.00.

38. Resolution – That the City of Fairhope has voted to purchase a 2014 Ford Crane Truck for Public Works Department to be used for painting of signs; and the type of vehicle needed is on the Alabama Department of Transportation (ALDOT) surplus equipment list. The total cost not to exceed \$30,000.00.
39. Request – Eastern Shore Optimist Club – Requesting an in-kind donation to use the Fairhope Civic Center for the Dogwood Trail Pageant 2021 and the Delchamps Suite for the Arts and Crafts Reception in 2021.
40. Request - Golf Green Fees and Cart Fees for the Fairhope Educational Enrichment Foundation (“FEEF”) Golf Tournament.
41. Request - Fairhope Arts and Crafts Committee – Requesting permission to reschedule the Fairhope Arts and Crafts Festival for April 30, 2021, May 1, 2021, and May 2, 2021; and all requests (including use of streets) pursuant to the Memorandum of Understanding between the City of Fairhope and the Fairhope Arts and Crafts Festival Foundation.
42. Request – Gene Broadus, Eastern Shore Optimist Club – Requesting permission to hold the Easter Sunrise Service at 6:30 a.m. at the Fairhope Municipal Fountain; and help with traffic and securing the location for pedestrians.
43. Request – Erin Langley, Eastern Shore Repertory Theatre, Inc. - Requesting permission to use Henry George Park from April 29, 2021 through May 9, 2021 for the performance of the classic, “The Wizard of Oz” with performances being held May 6, 2021 through May 8, 2021 with a rain date or possible encore performance on May 9, 2021 (paid in 2020 but cancelled due to COVID; and will use payment for 2021 program); and usage of barricades and to have City employees assist in setup and removal of these. Pursuant to Ordinance No. 1486, ESRT will be responsible for security costs.
44. Application for Special Retail Liquor License – More than 30 day by Kirk Dye for Southern Chill, LLC d/b/a/ as Southern Chill located at 85 N. Bancroft Street, Fairhope, Alabama.
45. Application for a Restaurant Liquor License by David J. Jewett for Malinoisplaytime, LLC d/b/a Café 98, located at 901 Fairhope Avenue, Fairhope, Alabama.
46. Fairhope Environmental Advisory Board - Appointment and Reappointments
47. Board of Adjustments & Appeals – Appointments for Alternate Members
48. Public Participation – (3 minutes maximum)
49. Executive Session – To discuss pending and potential litigation and Section 36-25A-7(a)(4) to discuss security plans, procedures, assessments, measures, or systems, or the security or safety of persons, structures, facilities, or other infrastructures, the public disclosure of which could reasonably be expected to be detrimental to public safety or welfare.
50. Adjourn

**City Council Work Session - 4:30 p.m.  
on Monday, February 22, 2021 – Council Chambers**

**City Council Agenda Meeting - 5:30 p.m.  
on Monday, February 22, 2021 – Council Chambers**

**Next Regular Meeting – Monday, March 8, 2021 - Same Time and Place**

STATE OF ALABAMA                    )(  
  :  
COUNTY OF BALDWIN                )(

The City Council, City of Fairhope, met in regular session at 6:00 p.m., Fairhope Municipal Complex Council Chamber, 161 North Section Street, Fairhope, Alabama 36532, on Monday, 8 February 2021.

Present were Council President Jack Burrell, Councilmembers: Corey Martin, Jimmy Conyers, Robert Brown, and Kevin Boone, Mayor Sherry Sullivan, City Attorney Marcus E. McDowell, and City Clerk Lisa A. Hanks.

There being a quorum present, Council President Burrell called the meeting to order. The invocation was given by Assistant Pastor Andrew Lehman of Redeemer Lutheran Church, and the Pledge of Allegiance was recited. Councilmember Conyers moved to approve minutes of the 25 January 2021, regular meeting; minutes of the 25 January 2021, work session; and minutes of the 25 January 2021, agenda meeting. Seconded by Councilmember Boone, motion passed unanimously by voice vote.

Mayor Sullivan addressed the City Council regarding the following items:

- 1) Recognized two employees for iHealthy: Laura Selby and Ashley Tucker who won \$250.00 for their participation and completion of the first Wellness Challenge;
- 2) Task Force met regarding Nichols Avenue and will be recommending speed table, cross walk, and possibly signals;
- 3) Thanked Thomas Hospital, Police Department, and 3 Circle Church for the COVID-019 vaccine clinic held; and said there would be another clinic on February 27, 2021; and
- 4) Thanked Councilmember Martin and Council President Burrell, other Councilmembers, and Staff for working with Budget, particularly City Treasurer Kim Creech and Finance Manager Jill Cabaniss.

Councilmember Conyers thanked the volunteer members on the Planning Commission and Staff for their work during the six hour Planning Commission meeting.

Council President Burrell stated he had been asked for the City to sponsor a COVID-19 vaccine clinic. He said that hospitals and doctors get the vaccine not the City.

8 February 2021

A Public Hearing was held as advertised on a proposed ordinance to amend Zoning Ordinance No. 1253. Councilmember Conyers introduced in writing an ordinance to amend Article V, Section B. Central Business District. f. Fifty Percent (50%) of the gross floor area on the ground floor of a building in CBD shall be dedicated to commercial use. The Planning Commission gave a favorable recommendation of this ordinance. Council President Burrell read the proposed ordinance.

Planning and Zoning Manager Hunter Simmons briefly explained the proposed ordinance. Council President Burrell questioned single family residents that are already allowed in B-2. Mr. Simmons said mixed-use is where we were focusing on. It was suggested to change the wording to allow single family residents. City Attorney Marcus McDowell and City Clerk Lisa Hanks both said the ordinance would need to be readvertised due to the change would be significant.

Council President Burrell opened the Public Hearing at 6:22 p.m. No one present opposed the proposed ordinance, the Public Hearing closed at 6:22 p.m. City Clerk Hanks explained that the Code of Alabama requires a zoning ordinance to be advertised two consecutive weeks: first publication is the entire ordinance, and the second publication is a synopsis of the ordinance. She stated the public hearing could be held if the meeting is at least 15 days after the last publication.

A Public Hearing was held as advertised on a proposed ordinance to an Ordinance to amend Zoning Ordinance No. 1253. Councilmember Conyers introduced in writing an ordinance to amend Article V, Adding HTD – Highway Transitional District; Article III. Section B. Table 3-1: Use Table adding column for HTD permitted uses; and Article III, Section B. Table 3-2: Dimension Table adding row for HTD. The Planning Commission gave a favorable recommendation of this ordinance. Council President Burrell read the proposed ordinance.

Planning and Zoning Manager Hunter Simmons briefly explained the proposed ordinance.

Council President Burrell opened the Public Hearing at 6:29 p.m. No one present opposed the proposed ordinance, the Public Hearing closed at 6:29 p.m.

Due to lack of a motion for immediate consideration, this ordinance will layover until the February 22, 2021 City Council meeting. Mr. Simmons explained the Use Table pursuant to this ordinance.

8 February 2021

A Public Hearing was held as advertised on a proposed ordinance to amend Zoning Ordinance No. 1253. Councilmember Boone introduced in writing an ordinance to rezone the property of Seaman Capital, LLC/Dominion Partners from R-1 Low Density Single Family Residential District to Planned Unit Development (PUD). The property generally located at southwest of the intersection of Greeno Road and Volanta Avenue, Fairhope, Alabama. PPIN Numbers: 386193 and 386197. The property to be known as The Reserve at Fairhope PUD. The Planning Commission gave a favorable recommendation of this ordinance. Council President Burrell read the proposed ordinance.

Planning and Zoning Manager Hunter Simmons briefly explained the proposed ordinance. Council President Burrell questioned buffer if turn lanes are installed on Volanta. Mr. Simmons replied a buffer would have to remain and there is still 20 feet on their property not on right-of-way. Engineer of Record Trey Jinright said he has been working with the City for over a year on this project. He said they would maintain a 30 foot buffer and added a 20 foot landscape buffer. Mr. Jinright said they made buildings to be comfortable with residential property; and there is significant open space with the PUD.

Council President Burrell opened the Public Hearing at 6:50 p.m.

- 1) Carol Schneider, 113 Orange Street, addressed the City Council and said this development is very important for Fairhope; and will be valuable to the Community. She commented there are only a few places for older residents to live and those are getting crowded.

No one present opposed the proposed ordinance, the Public Hearing closed at 6:51 p.m. Councilmember Boone questioned drainage; and said we had issues once and had to purchase the Cedar property. Mr. Jinright said it drains to the South; and we have ample property for drainage retention. Councilmember Martin questioned infrastructure for the site; and said we must take care of our underlying issues.

Due to lack of a motion for immediate consideration, this ordinance will layover until the February 22, 2021 City Council meeting.

Councilmember Boone moved for final adoption of Ordinance No. 1698, an Ordinance to amend Zoning Ordinance No. 1253 and to rezone the property of Hermitage, LLC, from R-1 Single Family Residential District to Planned Unit Development (PUD). This property is generally located on the west side of Blue Island Avenue between Gayfer Road and Fairhope Avenue, Fairhope, Alabama. PPIN #77742. The property to be known as Hermitage Court. (Introduced at the January 25, 2021 City Council Meeting) Seconded by Councilmember Martin, motion for final adoption passed by the following voice votes: AYE – Burrell, Martin, Conyers, Brown, and Boone. NAY – None.

8 February 2021

Councilmember Boone moved for final adoption of Ordinance No. 1699, an Ordinance to annex Clay G. Spencer, Lee R. Spencer, and Fairhope Single Tax Corporation property located at 20657 Northwood Drive, Fairhope, Alabama. Tax Parcel 46-06-14-0-000-001.813. (Introduced at the January 25, 2021 City Council Meeting) Seconded by Councilmember Conyers, motion for final adoption passed by the following voice votes: AYE – Burrell, Martin, Conyers, Brown, and Boone. NAY – None.

Councilmember Conyers moved for final adoption of Ordinance No. 1700, an Ordinance to annex Parker Road from U. S. Highway 98 easterly approximately 1,373 feet to the end of County maintenance to the corporate limits of the City of Fairhope from Baldwin County Commission. (Introduced at the January 25, 2021 City Council Meeting) Seconded by Councilmember Boone, motion for final adoption passed by the following voice votes: AYE – Burrell, Martin, Conyers, Brown, and Boone. NAY – None.

Councilmember Brown moved for final adoption of Ordinance No. 1701, an Ordinance amending Ordinance No. 611 and to amend and add to Chapter 21, Article V, Gas, Fairhope Code of Ordinances: Meter Deposit, Installation of New Gas Service Fees, Inspection Fees of Gas Installation, and Tampering by Customer and Contractor. (Introduced at the January 25, 2021 City Council Meeting) Seconded by Councilmember Boone, motion for final adoption passed by the following voice votes: AYE – Burrell, Martin, Conyers, Brown, and Boone. NAY – None.

Councilmember Martin introduced in writing an Ordinance amending Ordinance No. 1312 (Section 16); and to repeal and replace Ordinance No. 1468, known as the Towing and Recovery Rotation Ordinance. This is Section 22-56 in the City of Fairhope's Code of Ordinances. Due to lack of a motion for immediate consideration, this ordinance will layover until the February 22, 2021 City Council meeting.

Councilmember Brown introduced in writing, and moved for the adoption of the following resolution, a resolution for the approval of the FY 2020-2021 Budget. The motion was seconded by Councilmember Conyers. Council President Burrell explained the resolution for the budget; and said the budget is a living document. He mentioned the two percent raise for all employees this fiscal year even if an employee has maxed out. Council President Burrell stated in the fourth paragraph that the wording up to the \$2,500,000.00 reduction needs to be without the word "reduction." After further discussion, motion passed unanimously by voice vote.



8 February 2021

**RESOLUTION NO. 3961-21**

**BE IT RESOLVED BY THE GOVERNING BODY OF THE CITY OF FAIRHOPE, ALABAMA**, that the proposed Budget presented and reviewed the 8th day of February 2021, be hereby approved, and adopted for the FY 2020-2021; and

**BE IT FURTHER RESOLVED**, that the Annual Salaries of City Personnel shall be as shown on a list entitled Annual Salaries of All City Personnel and said list filed in the Office of the City Treasurer; and

**BE IT FURTHER RESOLVED** that the City Council hereby authorizes the portion of the Sales and Use Tax revenue that is restricted in the General Fund Debt Pre-Payment Account can be used for General Fund operations up to the \$2,500,000.00 reduction; and

**BE IT FURTHER RESOLVED** that the City Council hereby authorizes the portion of the Sales and Use Tax revenue that is restricted in the Capital Projects Fund (Infrastructure Improvements Special Fund) can be used for General Fund operations up to the \$2,500,000.00; and

**BE IT FURTHER RESOLVED**, that the City Council hereby approves the 2% raise across all Departments: General Government and Utilities including employees capped for this budget; and pay raises for the City of Fairhope (already included in proposed budget) for all full-time and part-time employees who have worked consistently more than 19 hours per week in the past 6 months; and

**BE IT FURTHER RESOLVED**, that all raises and salary changes adopted in the budget will become effective the day of passage.

ADOPTED THIS 8TH DAY OF FEBRUARY, 2021

\_\_\_\_\_  
Jack Burrell, Council President

ATTEST:

\_\_\_\_\_  
Lisa A. Hanks, MMC  
City Clerk

8 February 2021

Councilmember Martin introduced in writing, and moved for the adoption of the following resolution, a resolution that the City Council hereby approves and authorizes the City of Fairhope to execute a Memorandum of Understanding between the Baldwin County Board of Education and the City of Fairhope for Salary Enhancement for Fairhope Coaches with a budgeted amount of \$75,000.00 which shall include all employer fringe benefits associated with the Salary Enhancement as calculated by the Board. Seconded by Councilmember Conyers, motion passed unanimously by voice vote.

**RESOLUTION NO. 3962-21**

**BE IT RESOLVED BY THE GOVERNING BODY OF THE CITY OF FAIRHOPE, ALABAMA,** that the City Council hereby approves and authorizes the City of Fairhope to execute a Memorandum of Understanding between the Baldwin County Board of Education and the City of Fairhope for Salary Enhancement for Fairhope Coaches with a budgeted amount of \$75,000.00 which shall include all employer fringe benefits associated with the Salary Enhancement as calculated by the Board.

Adopted on this 8th day of February, 2021

\_\_\_\_\_  
Jack Burrell, Council President

Attest:

\_\_\_\_\_  
Lisa A. Hanks, MMC  
City Clerk

Councilmember Brown asked if Agenda Item #34 could be addressed now since there were individuals in the audience from the Point Clear Rotary Club that need not wait until the end of the agenda.

Councilmember Martin introduced in writing, and moved for the adoption of the following resolution, a resolution that the Fairhope City Council hereby accepts the Renovation Gift for the Waterfront Butterfly Information Stand from the Point Clear Rotary Club and approves the design as presented. Seconded by Councilmember Conyers, motion passed unanimously by voice vote.

8 February 2021

**RESOLUTION NO. 3963-21**

**BE IT RESOLVED BY THE GOVERNING BODY OF THE CITY OF FAIRHOPE, ALABAMA,** That the Fairhope City Council hereby accepts the Renovation Gift for the Waterfront Butterfly Information Stand from the Point Clear Rotary Club and approves the design as presented.

Adopted on this 8th day of February, 2021

\_\_\_\_\_  
Jack Burrell, Council President

Attest:

\_\_\_\_\_  
Lisa A. Hanks, MMC  
City Clerk

Councilmember Conyers introduced in writing, and moved for the adoption of the following resolution, a resolution that Mayor Sherry Sullivan is hereby authorized to execute a ground lease between the City of Fairhope, Alabama and the Local Food Production Initiative, Inc. d/b/a Fairhope Community Gardens. The parcel is located on the West side of Summit Street, a delineated and fenced portion of the grounds of the K-1 Center. Seconded by Councilmember Martin, motion passed unanimously by voice vote.

**RESOLUTION NO. 3964-21**

**BE IT RESOLVED BY THE GOVERNING BODY OF THE CITY OF FAIRHOPE, ALABAMA,** that Mayor Sherry Sullivan is hereby authorized to execute a ground lease between the City of Fairhope, Alabama and the Local Food Production Initiative, Inc. d/b/a Fairhope Community Gardens. The parcel is located on the West side of Summit Street, a delineated and fenced portion of the grounds of the K-1 Center.

Adopted on this 8th day of February, 2021

\_\_\_\_\_  
Jack Burrell, Council President

Attest:

\_\_\_\_\_  
Lisa A. Hanks, MMC  
City Clerk

8 February 2021

Councilmember Conyers introduced in writing, and moved for the adoption of the following resolution, a resolution that the City of Fairhope hereby approves the services outlined, as presented in the Engagement Letter, to be performed by Hand Arendall Harrison Sale as bond counsel to the Fairhope Airport Authority and the City of Fairhope in connection with the issuance of the proposed Bond Issuance of the Fairhope Airport Authority; and authorizes Mayor Sherry Sullivan to execute same on behalf of the City. Seconded by Councilmember Boone, motion passed unanimously by voice vote.

**RESOLUTION NO. 3965-21**

**BE IT RESOLVED BY THE GOVERNING BODY OF THE CITY OF FAIRHOPE**, That the City of Fairhope hereby approves the services outlined, as presented in the Engagement Letter, to be performed by Hand Arendall Harrison Sale as bond counsel to the Fairhope Airport Authority and the City of Fairhope in connection with the issuance of the proposed Bond Issuance of the Fairhope Airport Authority; and authorizes Mayor Sherry Sullivan to execute same on behalf of the City.

Adopted on this 8th day of February, 2021

---

Jack Burrell, Council President

Attest:

---

Lisa A. Hanks, MMC  
City Clerk

Councilmember Boone introduced in writing, and moved for the adoption of the following resolution, a resolution that the City Council approves the selection of Marissa Thetford Marketing to perform Professional Consulting Services for Fairhope City Sketches Graphics Design Services (RFQ PS007-21); and hereby authorizes Mayor Sherry Sullivan to negotiate a fee schedule and establish a not-to-exceed limit with this firm. Seconded by Councilmember Conyers, motion passed unanimously by voice vote.

8 February 2021

**RESOLUTION NO. 3966-21**

**BE IT RESOLVED BY THE GOVERNING BODY OF THE CITY OF FAIRHOPE, ALABAMA**, That the City Council approves the selection of Marissa Thetford Marketing to perform Professional Consulting Services for Fairhope City Sketches Graphics Design Services (RFQ PS007-21); and hereby authorizes Mayor Sherry Sullivan to negotiate a fee schedule and establish a not-to-exceed limit with this firm.

DULY ADOPTED THIS 8TH DAY OF FEBRUARY, 2021

\_\_\_\_\_  
Jack Burrell, Council President

Attest:

\_\_\_\_\_  
Lisa A. Hanks, MMC  
City Clerk

Councilmember Brown introduced in writing, and moved for the adoption of the following resolution, a resolution that City Council approves Amendment No. 1 to the Contract for Professional Design and CEI Engineering Services with Lieb Engineering Company, Inc. to enlist for Construction Engineering and Inspection (CE&I) Services for Oak Street and Section Street Drainage Improvements at Big Mouth Gully (RFQ PS-005-20) with a cost of \$3,250.00; thereby increasing the original contract total to \$18,845.00. Seconded by Councilmember Boone, motion passed unanimously by voice vote.

**RESOLUTION NO. 3967-21**

**BE IT RESOLVED BY THE GOVERNING BODY OF THE CITY OF FAIRHOPE, ALABAMA**, that City Council approves Amendment No. 1 to the Contract for Professional Design and CEI Engineering Services with Lieb Engineering Company, Inc. to enlist for Construction Engineering and Inspection (CE&I) Services for Oak Street and Section Street Drainage Improvements at Big Mouth Gully (RFQ PS005-20) with a cost of \$3,250.00; thereby increasing the original contract total to \$18,845.00.

Adopted on this 8th day of February, 2021

\_\_\_\_\_  
Jack Burrell, Council President

Attest:

\_\_\_\_\_  
Lisa A. Hanks, MMC  
City Clerk

8 February 2021

Councilmember Brown introduced in writing, and moved for the adoption of the following resolution, a resolution that City Council approves Amendment No. 1 to the Contract for Professional Consultant Services with Magnolia River for (RFQ No. PS015-18), Cast Iron Replacement Program with System Mapping and System Modeling for the Gas Department: Deletion of Item #1: Review the Natural Gas System Maps in the amount of (\$25,000.00) and Item #4: Creation 5-year plan for Cast Iron Replacement in the amount of (\$5,000.00); and by adding Emergency Valve Review in the amount of \$7,500.00. This is a deduction of (\$22,500.00) for the Project. Seconded by Councilmember Conyers, motion passed unanimously by voice vote.

**RESOLUTION NO. 3968-21**

**BE IT RESOLVED BY THE GOVERNING BODY OF THE CITY OF FAIRHOPE, ALABAMA**, that City Council approves Amendment No. 1 to the Contract for Professional Consultant Services with Magnolia River for RFQ No. PS015-18, Cast Iron Replacement Program with System Mapping and System Modeling for the Gas Department: Deletion of Item #1: Review the Natural Gas System Maps in the amount of (\$25,000.00) and Item #4: Creation 5-year plan for Cast Iron Replacement in the amount of (\$5,000.00); and by adding Emergency Valve Review in the amount of \$7,500.00. This is a deduction of (\$22,500.00) for the Project.

Adopted on this 8th day of February, 2021

\_\_\_\_\_  
Jack Burrell, Council President

Attest:

\_\_\_\_\_  
Lisa A. Hanks, MMC  
City Clerk

Councilmember Conyers introduced in writing, and moved for the adoption of the following resolution, a resolution that City Council approves the selection of Ameri'ca Designs, LLC for Professional Artist Consultant Services (RFQ PS008-21) for Mullet Run Fountain Refurbish and Retile Work by the Artist per the recommendation of Community Affairs Director and Water and Sewer Superintendent; and hereby authorizes Mayor Sherry Sullivan to execute a contract with a total cost of \$14,100.00 which is an unbudgeted item. Seconded by Councilmember Martin, motion passed unanimously by voice vote.

8 February 2021

**RESOLUTION NO. 3969-21**

**BE IT RESOLVED BY THE GOVERNING BODY OF THE CITY OF FAIRHOPE, ALABAMA**, that the City Council approves the selection of Ameri'ca Designs, LLC for Professional Artist Consultant Services (RFQ PS008-21) for Mullet Run Fountain Refurbish and Rtile Work by the Artist per the recommendation of Community Affairs Director and Water and Sewer Superintendent; and hereby authorizes Mayor Sherry Sullivan to execute a contract with a total cost of \$14,100.00 which is an unbudgeted item.

DULY ADOPTED THIS 8TH DAY OF FEBRUARY, 2021

\_\_\_\_\_  
Jack Burrell, Council President

Attest:

\_\_\_\_\_  
Lisa A. Hanks, MMC  
City Clerk

Councilmember Brown introduced in writing, and moved for the adoption of the following resolution, a resolution that Mayor Sherry Sullivan is hereby authorized to execute a contract with Stewart Engineering, Inc. to perform On-Call Professional Engineering Services for the Electric Department Projects for a Three (3) Year Agreement (RFQ No. PS005-21), with a not-to-exceed amount of \$25,000.00 per year, for a total contract amount of \$75,000.00. Seconded by Councilmember Martin, motion passed unanimously by voice vote.

**RESOLUTION NO. 3970-21**

**BE IT RESOLVED BY THE GOVERNING BODY OF THE CITY OF FAIRHOPE, ALABAMA**, that Mayor Sherry Sullivan is hereby authorized to execute a contract with Stewart Engineering, Inc. to perform On-Call Professional Engineering Services for the Electric Department Projects for a Three (3) Agreement (RFQ No. PS005-21), with a not-to-exceed amount of \$25,000.00 per year, for a total contract amount of \$75,000.00.

DULY ADOPTED THIS 8TH DAY OF FEBRUARY, 2021

\_\_\_\_\_  
Jack Burrell, Council President

Attest:

\_\_\_\_\_  
Lisa A. Hanks, MMC  
City Clerk

8 February 2021

Councilmember Boone introduced in writing, and moved for the adoption of the following resolution, a resolution that the City Council approves Amendment No. 2 to the Contract and amending Resolution No. 3097-18 for RFQ No. PS014-18, Professional Engineering Services for Sawgrass Consulting, LLC for Wastewater Collection and Transmission System Improvements for Project #1: Church Street Outfall Transmission System for CE&I Services at an estimated cost of \$393,859.98; and authorize the Mayor to execute Amendment No. 2. Seconded by Councilmember Brown, motion passed unanimously by voice vote.

**RESOLUTION NO. 3971-21**

**BE IT RESOLVED BY THE GOVERNING BODY OF THE CITY OF FAIRHOPE, ALABAMA**, that City Council approves Amendment No. 2 to the Contract and amending Resolution No. 3097-18 for RFQ No. PS014-18, Professional Engineering Services for Sawgrass Consulting, LLC for Wastewater Collection and Transmission System Improvements for Project #1: Church Street Outfall Transmission System for CE&I Services at an estimated cost of \$393,859.98; and authorize the Mayor to execute the Contract Amendment.

DULY ADOPTED THIS 8TH DAY OF FEBRUARY, 2021

\_\_\_\_\_  
Jack Burrell, Council President

Attest:

\_\_\_\_\_  
Lisa A. Hanks, MMC  
City Clerk

Councilmember Conyers introduced in writing, and moved for the adoption of the following resolution, a resolution that the Governing Body of the City of Fairhope, Alabama, hereby rejects all bids for Bid No. 006-21 Beverage Vending and Concessions 2021 – Three Year for the Recreation Department (only one Valid Bid was received); and authorizes the Mayor to negotiate a contract with the one bidder, pursuant to the Code of Alabama 1975, Section 39-2-6(b). Seconded by Councilmember Martin, motion passed unanimously by voice vote.

\*

\*



8 February 2021

**RESOLUTION NO. 3972-21**

**BE IT RESOLVED BY THE GOVERNING BODY OF THE CITY OF FAIRHOPE, ALABAMA**, as follows:

[1] That the City of Fairhope did request, receive, and open bids for Beverage Vending and Concessions 2021 – Three Year for the Recreation Department for the Recreation Department (Bid Number 006-21) at 555 South Section Street in the City of Fairhope offices, Fairhope, Alabama.

[2] At the appointed time and place, the bids were opened and tabulated.

[3] After evaluating the bid proposals with the required bid specifications, only one valid bid was received and we request that all bids be rejected for Beverage Vending and Concessions 2021 – Three Year for the Recreation Department Bid No. 006-21; and authorize the Mayor to negotiate a contract with the one bidder, pursuant to the Code of Alabama 1975, Section 39-2-6(b).

Adopted on this 8th day of February, 2021

\_\_\_\_\_  
Jack Burrell, Council President

Attest:

\_\_\_\_\_  
Lisa A. Hanks, MMC  
City Clerk

Councilmember Conyers introduced in writing, and moved for the adoption of the following resolution, a resolution that the Governing Body of the City of Fairhope, Alabama, hereby rejects all bids for Bid No. 013-21 Fairhope Connect Newsletter Printing and Re-Bid with new name of Newsletter and specifications for the Community Affairs Department; and authorizes staff to rebid. Seconded by Councilmember Boone, motion passed unanimously by voice vote.

\*

\*

8 February 2021

**RESOLUTION NO. 3972-21**

**BE IT RESOLVED BY THE GOVERNING BODY OF THE CITY OF FAIRHOPE, ALABAMA**, as follows:

[1] That the City of Fairhope did request, receive, and open bids for Fairhope Connect Newsletter Printing and Re-Bid with new name of Newsletter and specifications for the Community Affairs Department (Bid Number 013-21) at 555 South Section Street in the City of Fairhope offices, Fairhope, Alabama.

[2] At the appointed time and place, the bids were opened and tabulated.

[3] After evaluating the bid proposals with the required bid specifications, we request that all bids be rejected for Bid No. 013-21 Fairhope Connect Newsletter Printing and Re-Bid with new name of Newsletter and specifications for the Community Affairs Department; and authorizes staff to rebid.

Adopted on this 8th day of February, 2021

---

Jack Burrell, Council President

Attest:

---

Lisa A. Hanks, MMC  
City Clerk

Councilmember Conyers introduced in writing, and moved for the adoption of the following resolution, a resolution that Mayor Sherry Sullivan is hereby authorized to execute a contract for Extension No. 1 of Bid No. 020-20, Lift Station Odor Control Chemical for the Sewer Department, with ChemStation Gulf Coast for an additional one year, as per the terms and conditions of the original contract. The total bid proposal of \$5.70 per metered gallon, for an estimated annual cost of \$213,248.40. Seconded by Councilmember Martin, motion passed unanimously by voice vote.

8 February 2021

**RESOLUTION NO. 3974-21**

**BE IT RESOLVED BY THE GOVERNING BODY OF THE CITY OF FAIRHOPE, ALABAMA**, that Mayor Sherry Sullivan is hereby authorized to execute a contract for Extension No. 1 of Bid No. 020-20, Lift Station Odor Control Chemical for the Sewer Department, with ChemStation Gulf Coast for an additional one year, as per the terms and conditions of the original contract. The total bid proposal of \$5.70 per metered gallon, for an estimated annual cost of \$213,248.40.

Adopted on this 8th day of February, 2021

\_\_\_\_\_  
Jack Burrell, Council President

Attest:

\_\_\_\_\_  
Lisa A. Hanks, MMC  
City Clerk

Councilmember Martin introduced in writing, and moved for the adoption of the following resolution, a resolution that the City of Fairhope has voted to purchase Annual Service Agreement for the Dispatch Console for the Fairhope Police Department; from Motorola Solutions, Inc. as Sole Source Distributor; and authorizes procurement based on the option allowed by the Code of Alabama 1975, Section 41-16-51(15). The cost will be \$27,992.42. Seconded by Councilmember Brown, motion passed unanimously by voice vote.

\*

\*

\*

\*

8 February 2021

**RESOLUTION NO. 3975-21**

**BE IT RESOLVED BY THE GOVERNING BODY OF THE CITY OF FAIRHOPE, ALABAMA, as follows:**

[1] That the City of Fairhope has voted to purchase Annual Service Agreement for the Dispatch Console for the Fairhope Police Department; from Motorola Solutions, Inc. as Sole Source Distributor; and authorizes procurement based on the option allowed by the Code of Alabama 1975, Section 41-16-51(15): “Contractual services and purchases of products related to, or having an impact upon, security plans, procedures, assessments, measures, or systems, or the security or safety of persons, structures, facilities, or infrastructures.” The cost will be \$27,992.42.

Adopted on this 8th day of February, 2021

---

Jack Burrell, Council President

Attest:

---

Lisa A. Hanks, MMC  
City Clerk

Councilmember Conyers introduced in writing, and moved for the adoption of the following resolution, a resolution that the City of Fairhope approves the procurement for a Fence located to the South at the Public Works Facility damaged by Hurricane Sally (FEMA 4563). This Request for Quotes was sent to fifteen (15) contractors as well as multiple State agencies for MBE and DEB consideration. The City received three quotes; and awards the project to Consolidated Fence Co. in the amount of \$11,667.00. An insurance claim has been filed; and once the claim is done, then FEMA claim will be submitted. Seconded by Councilmember Martin, motion passed unanimously by voice vote.

\*

\*

8 February 2021

**RESOLUTION NO. 3976-21**

**BE IT RESOLVED BY THE GOVERNING BODY OF THE CITY OF FAIRHOPE, ALABAMA, as follows:**

[1] That the City of Fairhope approves the procurement for a Fence located to the South at the Public Works Facility damaged by Hurricane Sally (FEMA 4563). This Request for Quotes was sent to fifteen (15) contractors as well as multiple State agencies for MBE and DEB consideration. The City received three quotes; and awards the project to Consolidated Fence Co. in the amount of \$11,667.00. An insurance claim has been filed; and once the claim is done, then FEMA claim will be submitted.

Adopted on this 8th day of February, 2021

---

Jack Burrell, Council President

Attest:

---

Lisa A. Hanks, MMC  
City Clerk

Councilmember Conyers introduced in writing, and moved for the adoption of the following resolution, a resolution that the City of Fairhope approves the procurement for Roof Repairs to Various Roofs at the Founders Park damaged by Hurricane Sally (FEMA 4563). This Request for Quotes was sent to eight (8) contractors as well as multiple State agencies for MBE and DEB consideration. The initial request received no quotes, so the City solicited quotes a second time and received one quote; and awards the project to Roof Doctors of Alabama in the amount of \$38,700.00. An insurance claim has been filed; and once the claim is done, then FEMA claim will be submitted. Seconded by Councilmember Boone, motion passed unanimously by voice vote.

\*

\*

8 February 2021

**RESOLUTION NO. 3977-21**

**BE IT RESOLVED BY THE GOVERNING BODY OF THE CITY OF FAIRHOPE, ALABAMA, as follows:**

[1] That the City of Fairhope approves the procurement for Roof Repairs to Various Roofs at the Founders Park damaged by Hurricane Sally (FEMA 4563). This Request for Quotes was sent to eight (8) contractors as well as multiple State agencies for MBE and DEB consideration. The initial request received no quotes, so the City solicited quotes a second time and received one quote; and awards the project to Roof Doctors of Alabama in the amount of \$38,700.00. An insurance claim has been filed; and once the claim is done, then FEMA claim will be submitted.

Adopted on this 8th day of February, 2021

---

Jack Burrell, Council President

Attest:

---

Lisa A. Hanks, MMC  
City Clerk

Councilmember Conyers introduced in writing, and moved for the adoption of the following resolution, a resolution that the City of Fairhope approves the procurement for Roof Repairs to Various Roofs at the Fairhope Recreation Center damaged by Hurricane Sally (FEMA 4563). This Request for Quotes was sent to eight (8) contractors as well as multiple State agencies for MBE and DEB consideration. The initial request received no quotes, so the City solicited quotes a second time and received one quote; and awards the project to Roof Doctors of Alabama in the amount of \$17,550.00. An insurance claim has been filed; and once the claim is done, then FEMA claim will be submitted. Seconded by Councilmember Martin, motion passed unanimously by voice vote.

\*

\*

8 February 2021

**RESOLUTION NO. 3978-21**

**BE IT RESOLVED BY THE GOVERNING BODY OF THE CITY OF FAIRHOPE, ALABAMA, as follows:**

[1] That the City of Fairhope approves the procurement for Roof Repairs to Various Roofs at the Fairhope Recreation Center damaged by Hurricane Sally (FEMA 4563). This Request for Quotes was sent to eight (8) contractors as well as multiple State agencies for MBE and DEB consideration. The initial request received no quotes, so the City solicited quotes a second time and received one quote; and awards the project to Roof Doctors of Alabama in the amount of \$17,550.00. An insurance claim has been filed; and once the claim is done, then FEMA claim will be submitted.

Adopted on this 8th day of February, 2021

---

Jack Burrell, Council President

Attest:

---

Lisa A. Hanks, MMC  
City Clerk

Councilmember Conyers introduced in writing, and moved for the adoption of the following resolution, a resolution that the City of Fairhope has voted to purchase a 2021 Dodge Ram 5500 Diesel Crew Cab and Chassis with dual rear wheels for the Water Department; and the type of vehicle needed is on the Alabama State Department of Purchasing bid list and therefore does not have to be let out for bid. The cost will be \$50,172.00. Seconded by Councilmember Boone, motion passed unanimously by voice vote.

**RESOLUTION NO. 3979-21**

**BE IT RESOLVED BY THE GOVERNING BODY OF THE CITY OF FAIRHOPE, ALABAMA, as follows:**

[1] That the City of Fairhope has voted to purchase a 2021 Dodge Ram 5500 Diesel Crew Cab and Chassis with dual rear wheels for the Water Department; and the type of vehicle needed is on the Alabama State Department of Purchasing bid list and therefore does not have to be let out for bid; and

8 February 2021

[2] The following is the Alabama State Department of Purchasing contract information:

Bid Number: T193-A

2021 Dodge Ram 5500 Diesel      **Cost is \$50,172.00**  
Crew Cab and Chassis

Adopted on this 8th day of February, 2021

---

Jack Burrell, Council President

Attest:

---

Lisa A. Hanks, MMC  
City Clerk

Councilmember Martin introduced in writing, and moved for the adoption of the following resolution, a resolution that the City Council approves and adopts the recommendations for the Community Development Department Restructuring and Reclassification as follows: Reclassify Director of Community Affairs (Grade 28S) to Special Projects & Grant Manager (Grade 26S); and will report to the Mayor; Reclassify Tourism & Events Manager from (Grade 21S) to Director of Community Affairs (Grade 28S); and approves the pay increase included in the 2021 proposed budget; and Approves the Updated uniform Job Descriptions for Director of Community Affairs and Special Projects & Grant Manager. The motion was seconded by Councilmember Boone. Mayor Sullivan stated she agreed with the recommendations. She said Jessica Walker has done a great job with the Restore Act and grants. Mayor Sullivan stated she met with Diane Thomas, Chair of the Personnel Board for these job descriptions and pay grades; and will send to Auburn to put with their study. After further discussion, motion passed unanimously by voice vote.

\*

\*



8 February 2021

**RESOLUTION NO. 3980-21**

**BE IT RESOLVED BY THE GOVERNING BODY OF THE CITY OF FAIRHOPE, ALABAMA,** That the City Council approves and adopts the recommendations for the Community Development Department Restructuring and Reclassification as follows:

- 1) Reclassify Director of Community Affairs (Grade 28S) to Special Projects & Grant Manager (Grade 26S); and will report to the Mayor; and
- 2) Reclassify Tourism & Events Manager from (Grade 21S) to Director of Community Affairs (Grade 28S); and approves the pay increase included in the 2021 proposed budget; and
- 3) Approves the Updated uniform Job Descriptions for Director of Community Affairs and Special Projects & Grant Manager.

ADOPTED THIS 8TH DAY OF FEBRUARY, 2021

---

Jack Burrell, Council President

ATTEST:

---

Lisa A. Hanks, MMC  
City Clerk

Councilmember Boone introduced in writing, and moved for the adoption of the following resolution, a resolution that the City Council approves the revised and updated Job Description for the City Clerk as presented; and approves to move the City Clerk position from (Grade 28S) to (Grade 31S). The motion was seconded by Councilmember Martin. Council President Burrell explained the reason for the resolution. He said that City Clerk Lisa Hanks has done a great job; and has served as President of the Clerk's Association. Council President Burrell commented this will put Ms. Hanks on the same playing field as other Directors. He told Ms. Hanks that he, along with the Councilmembers and Mayor, appreciates her. Councilmember Martin commented she does a good job. After further discussion, motion passed unanimously by voice vote.

\*

\*

8 February 2021

**RESOLUTION NO. 3981-21**

**BE IT RESOLVED BY THE GOVERNING BODY OF THE CITY OF FAIRHOPE, ALABAMA,** That the City Council approves the revised and updated Job Description for the City Clerk as presented; and approves to move the City Clerk position from (Grade 28S) to (Grade 31S).

ADOPTED THIS 8TH DAY OF FEBRUARY, 2021

\_\_\_\_\_  
Jack Burrell, Council President

ATTEST:

\_\_\_\_\_  
Lisa A. Hanks, MMC  
City Clerk

Councilmember Boone introduced in writing, and moved for the adoption of the following resolution, a resolution that the City Council approves the recommendations from the Street and Traffic Control Committee's Task Force for the Twin Beech and Boothe Road Intersection: Lower speed limit between Highway 98 a/k/a Greeno Road and County Road 13 on Twin Beech Road a/k/a County Road 44 from 45 mph to 35 mph; Paint a Crosswalk across Boothe Road and across Twin Beech; and Construct about 100 feet of sidewalk on the southeast corner of intersection with a cost of approximately \$1,500.00. Seconded by Councilmember Brown, motion passed unanimously by voice vote.

**RESOLUTION NO. 3982-21**

**BE IT RESOLVED BY THE GOVERNING BODY OF THE CITY OF FAIRHOPE, ALABAMA,** That the City Council approves the recommendations from the Street and Traffic Control Committee's Task Force for the Twin Beech and Boothe Road Intersection:

- [1] Lower speed limit between Highway 98 a/k/a Greeno Road and County Road 13 on Twin Beech Road a/k/a County Road 44 from 45 mph to 35 mph;
- [2] Paint a Crosswalk across Boothe Road and across Twin Beech;
- [3] Construct about 100 feet of sidewalk on the southeast corner of intersection with a cost of approximately \$1,500.00.

Adopted on this 8th day of February, 2021

\_\_\_\_\_  
Jack Burrell, Council President

Attest:

\_\_\_\_\_  
Lisa A. Hanks, MMC  
City Clerk

8 February 2021

Councilmember Boone moved to approve the 180 day extension by Henry Wise, Owner of Wise Living Real Estate, LLC and Larry Smith, P.E. with S.E. Civil Engineering & Surveying of the Site Plan approval that was granted for the property located at the on 369 S. Mobile Street known as The Pier Street Market Place. The Site Plan was approved on May 28, 2020. Seconded by Councilmember Martin, motion passed unanimously by voice vote.

The following individuals spoke during Public Participation for Non-Agenda Items:

- 1) Dick Schneider, 113 Orange Street, addressed the City Council regarding the items being voted on and not having a comparison from last year; i.e., cost. Council President Burrell replied and gave an example of Agenda Item No. 25. Mr. Schneider said he was requesting cost for last year versus this year. Council President Burrell explained that all of these are discussed in the Work Session and Agenda Meeting.
- 2) Carol Schneider, 113 Orange Street, addressed the City Council regarding the consideration of bringing a little flock of ducks to the Duck Pond area.

Councilmember Martin moved to adjourn the meeting. Seconded by Councilmember Boone, motion passed unanimously by voice vote.

There being no further business to come before the City Council, the meeting was duly adjourned at 8:00 p.m.

---

Jack Burrell, Council President

---

Lisa A. Hanks, MMC  
City Clerk

STATE OF ALABAMA                    ) (  
  :  
COUNTY OF BALDWIN                ) (  
  :

The City Council met in a Work Session  
at 4:30 p.m., Fairhope Municipal Complex Council Chamber,  
161 North Section Street, Fairhope, Alabama 36532,  
on Monday, 8 February 2021.

Present were Council President Jack Burrell, Councilmembers: Corey Martin, Jimmy Conyers, Robert Brown, and Kevin Boone, Mayor Sherry Sullivan, City Attorney Marcus E. McDowell, and City Clerk Lisa A. Hanks.

Council President Burrell called the meeting to order at 4:30 p.m.

The following topics were discussed:

- The first item on the Agenda was the Sanitation Discussions. Public Works Director Richard Johnson addressed the City Council and explained the three scenarios for possibly increases. (See attached handout) Councilmember Conyers suggested a fourth scenarios with all of the cost increase being done at one time; and the need to level funding. Councilmember Martin commented we need to be at market price and cannot continue with a deficit in sanitation. The consensus of the City Council was to go ahead with the cost increase all at once; and the effective date would be April 1, 2021.
- The item on the Agenda was the Fairhope Arts and Crafts Committee regarding the Festival. Jodi Keating and Laura English addressed the City Council and said we will still maintain social distancing, have only Alabama artist, have hand sanitizing stations, and it will be scaled down. Council President Burrell said we must plan for the festival as we have for many events. Councilmember Martin commented the Arts and Crafts Festival is a gathering and not a good idea. He mentioned three family members who passed away recently from COVID-19. Councilmember Martin said adults will not follow the rules. Councilmember Conyers said planning needs to be done, but this will probably not happen. Councilmembers Brown and Boone both agreed that we should hold the Arts and Crafts Festival; and it do not feel comfortable do not show up. Council President Burrell said he was okay with postponing, but may have to pull the plug; and commented the Committee may do this themselves. The consensus of the City Council was to move forward; and to vote on the request at the next meeting.
- Finance Manager Jill Cabaniss addressed the City Council regarding Budget Discussions and answered any questions they had. Mayor Sullivan thanked Council President Burrell and Councilmember Martin for working all day Friday on the budget; and thanked Finance Manager Jill Cabaniss, City Treasurer Kim Creech, and Staff for their hard work on the budget. Council President Burrell thanked Mayor Wilson and Councilmember Martin for working all day Friday too.

Monday, February 8, 2021

Page -2-

Ms. Cabaniss stated there would be a two percent raise for all employees; and explained the new departments, updated sections from greensheets, personnel, and transfers. She said that capital improvements remained the same. Mayor Sullivan commented that the Recreations increase was for ADA improvements and baseball renovations for four fields. Councilmember Brown asked if there was a new thermostat for the Council Chambers.

- Councilmember Boone announced there would be a Harbor Board meeting on Wednesday.
- Council President Burrell gave an update on the Fairhope Airport Authority: RFP for Bond which would increase how soon it would be paid off; hangars to be built and rents need to be reasonable; and rate should be better with the City back the Bond. He said if we back this refinance, it should get the Airport on its feet without the City.
- Gas Superintendent Terry Holman addressed the City Council and gave a project update; and explained his new employees that need to be hired.
- Fire Chief Chris Ellis addressed the City Council and told them the new truck is here and getting ready at Sunbelt. He said it should be ready in two weeks.
- Recreation Director Pat White addressed the City Council and said the replastering has been completed. He said staff will brush to help it cure quicker. Mr. White said the tennis courts have been repaired since Hurricane Sally. He commented there are structural issues with the pool building due to humidity. Mr. White announced High School and Middle School soccer and Varsity baseball begins this week.
- Electric Superintendent Michael Allison addressed the City Council and gave a substation project update and replacing streetlights. The Morphy substation was questioned; and Mr. Allison said the landscaping will be upgraded and aesthetically pleasing.
- Water and Sewer Superintendent Jason Langley addressed the City Council and mentioned his truck was on the agenda tonight; and they begin interviews this week for the new crew. He said his employees are doing a great job; and need to be commended. The SCADA system was discussed.
- Planning and Zoning Manager Hunter Simmons addressed the City Council and mentioned items that will be on the March 1, 2021 Planning Commission meeting. He also mentioned family subdivisions, reduced fees for same, updated site plan review, and charges for legal advertisement.
- Community Affairs Director Jessica Walker addressed the City Council and explained the Fairhope App and how to resolve issues.

Monday, February 8, 2021  
Page -2-

There being no further business to come before the City Council, the meeting was duly adjourned at 5:40 p.m.

---

Jack Burrell, Council President

---

Lisa A. Hanks, MMC  
City Clerk

JURISDICTION NAME	SERVICE & COLLECTION		COST (Monthly Rates)		RECYCLING	COMMENTS
	Garbage	Trash	RESIDENTIAL	COMMERCIAL		
CITY OF DAPHNE	1x Week	1x Week	\$15.40		Suspended Program	3 Months Post Resumption of Recycle \$3.00 Increase to \$18.40
TOWN OF LOXLEY	1x Week	1x Week	\$20.48	\$25.82	NO	ADDITIONAL CONTAINERS \$10.20 MONTHLY
CITY OF ROBERTSDALE	1x Week	1x Week	\$16.00	\$32.50	NO	
CITY OF FOLEY	1x Week	1x Week	\$19.75	\$22.50	YES	
CITY OF SARALAND	2x Week	1x Week	\$20.20		YES	
CITY OF GULF SHORES	1x Week (N OF 2ND AVE)	1x Week	\$16.51		YES	ADDITIONAL CONTAINERS \$15.90 MONTHLY
	2x Week (S OF 2ND AVE)	1x Week	\$21.61		YES	
CITY OF SPANISH FORT	1x Week	Demand Based	\$16.58		YES + \$9.00 MONTHLY	
CITY OF ORANGE BEACH	2x Week	1x Week	\$16.25		YES (Every Other week)	
CITY OF BAY MINETTE	1x Week	1x Week	\$18.50		NO	
Baldwin County	1x Week	Call In - 1 per/month	\$16.00		NO	

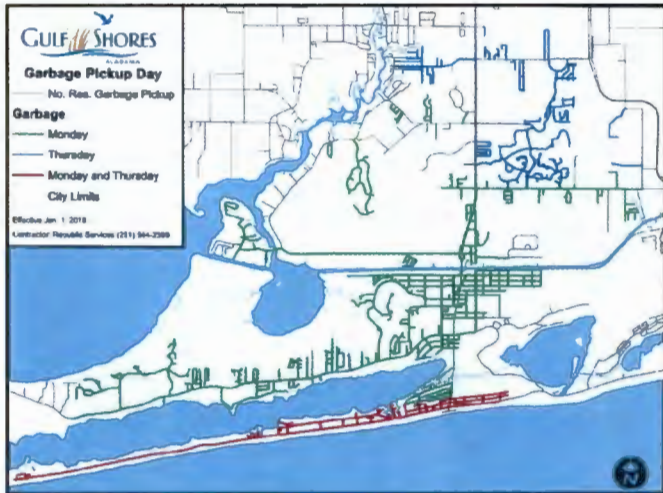

# City Of Fairhope - Solid Waste Account and Customer Data



Using Average Ten (10) Year Customer Growth Rate

2.20%

<b>Customer Information</b>	<b>As Of:</b>	<b>January 1, 2021</b>	
Customer Type	Rate	Count	Monthly Income
Residential Customers @	\$15.80	10255	\$162,029.00
Business Customers @	\$20.26	634	\$12,844.84
HC Customers @	\$20.00	29	\$580.00
<b>Total Customers/Monthly Income =</b>		<b>10918</b>	<b>\$175,453.84</b>

Equivalent Customer Units (ECU) = 11105  
 (Monthly Income/Residential Rate)

<b>Equivalent Customer Billing Units (01/01 of each Calendar Year)</b>							
Year	2021	2022	2023	2024	2025	2026	2027
ECU's	11105	11349	11599	11854	12115	12381	12654
<b>Projected Annual Income based on Residentail Rate x ECU - No Change in Rates</b>							
Income	\$2,105,446.08	\$2,151,765.89	\$2,199,104.74	\$2,247,485.05	\$2,296,929.72	\$2,347,462.17	\$2,399,106.34
Increase	\$0.00	\$46,319.81	\$47,338.85	\$48,380.30	\$49,444.67	\$50,532.45	\$51,644.17
<b>Option #1 - Increase of \$2.20 in year one, followed by \$1.00 per year for Years 2 &amp; 3 - \$4.20 Total</b>							
Year	2021	2022	2023	2024	2025	2026	2027
Rate	\$18.00	\$19.00	\$20.00	\$20.00	\$20.00	\$20.00	\$20.00
Income	\$2,398,609.46	\$2,587,566.58	\$2,783,676.89	\$2,844,917.78	\$2,907,505.97	\$2,971,471.10	\$3,036,843.47
Increase*	\$293,163.38	\$435,800.69	\$584,572.15	\$597,432.73	\$610,576.25	\$624,008.93	\$637,737.13
<b>Option #2 - Increase of \$1.20 in year one, followed by \$1.00 per year for Years 2 , 3 &amp; 4 - \$4.20 Total</b>							
Year	2021	2022	2023	2024	2025	2026	2027
Rate	\$17.00	\$18.00	\$19.00	\$20.00	\$20.00	\$20.00	\$20.00
Income	\$2,265,353.38	\$2,451,378.87	\$2,644,493.05	\$2,844,917.78	\$2,907,505.97	\$2,971,471.10	\$3,036,843.47
Increase*	\$159,907.30	\$299,612.97	\$445,388.30	\$597,432.73	\$610,576.25	\$624,008.93	\$637,737.13

\*Over the income with rates staying the same with no increase



STATE OF ALABAMA            )  
  :  
COUNTY OF BALDWIN        )(

The City Council met in an Agenda Meeting at 5:30 p.m.,  
Fairhope Municipal Complex Council Chamber,  
161 North Section Street, Fairhope, Alabama 36532,  
on Monday, 8 February 2021.

Present were Council President Jack Burrell, Councilmembers: Corey Martin, Jimmy Conyers, Robert Brown, and Kevin Boone, Mayor Sherry Sullivan, City Attorney Marcus E. McDowell, and City Clerk Lisa A. Hanks.

Council President Burrell called the meeting to order at 5:40 p.m. The City Council reviewed and discussed the agenda for their meeting to be held today at 6:00 p.m. Chief Stephanie Hollinghead, Community Affairs Director Jessica Walker, Public Works Director Richard Johnson, Recreation Director Pat White, and Electric Superintendent Michael Allison addressed the City Council and briefly explained their Department's Agenda Items.

There being no further business to come before the City Council, the meeting was duly adjourned at 5:57 p.m.

---

Jack Burrell, Council President

---

Lisa A. Hanks, MMC  
City Clerk

ORDINANCE NO. \_\_\_\_\_

AN ORDINANCE AMENDING ORDINANCE NO. 1253  
KNOWN AS THE ZONING ORDINANCE

The ordinance known as the Zoning Ordinance (No. 1253), adopted 27 June 2005, is changed and altered as described below;

**WHEREAS**, the City of Fairhope Planning Commission directed the Planning Department to prepare amendments to our Zoning Ordinance; and,

**WHEREAS**, the proposed amendments relate to the establishment of the Highway Transitional District; and,

**WHEREAS**, after the appropriate public notice and hearing of ZC 21.02, the Planning Commission of the City of Fairhope, Alabama has forwarded a favorable recommendation;

**NOW THEREFORE, BE IT ORDAINED BY THE CITY COUNCIL OF THE CITY OF FAIRHOPE, ALABAMA;**

1. **THAT**, Article V, be hereby amended to add the following:

**I. HTD - Highway Transitional District**

1. **Intent** - *The special standards listed in this section for the highway transitional district are intended to:*
  - *Provide an alternative to properties along state highways within the City of Fairhope that are beyond the area of influence of the Village Nodes and Commercial Nodes as contemplated by the City of Fairhope Comprehensive Plan.*
  - *Provide development opportunities consistent with the City's vision for commercial corridors to better serve community needs.*
  - *Unlike other districts within this section, the HTD is not an overlay district and does not affect any property owners, other than those who voluntarily apply for rezoning to this district.*
2. **Size** - *Lots shall be a minimum of 20,000 s.f. and under 3 acres.*
3. **Use** - *Uses for the HTD are listed in Table 3-1: Use Table. Rezoning to HTD may be conditioned so that uses permitted on appeal require a site plan.*
4. **Location** - *Eligible lots must have minimum of 100 feet on one side fronting the rights-of-way of U.S Highway 98, Alabama Highway 104, or Alabama Highway 181 and lie within the Corporate Jurisdiction of the City of Fairhope.*
5. **Dimension Standards** -
  - a. *Lot frontage shall be adjacent to the highway.*
  - b. **Setbacks**
    - i. *Front Setback shall be 20'.*
    - ii. *Rear Setback shall be 20'.*
    - iii. *Side setbacks shall be 10'.*
  - c. **Building Height**
    - i. *Maximum Height is 30'.*
    - ii. *A mixed-use building may have a height of 35' if it contains both residential and commercial space. The residential use must make up at least 33% of the total area of the building and be located on the second and/or third floor, and retail or office space must make up at least 50% of the total area of the building and be located on ground and/or second floor.*

- d. *Parking*
  - i. *Parking shall be located behind the front building line.*
- e. *Any freestanding single-use or tenant retail building shall not have a building footprint larger than 8,000 square feet.*
- f. *All lands within twenty (20) feet of the boundaries of U.S. Highway 98, Alabama Highway 104, and Alabama Highway 181 within the corporate limits of the City of Fairhope are required to be reserved by owners or developers of such lands as greenspace and tree protection zones. The required greenspace may include land as required by the front setback.*
  - i. *Where no vegetation, other than grass exists, new landscaping and plantings shall be installed at time of development within the 20-foot strip that meet the requirements of the City of Fairhope Tree Ordinance and receives approval by the City Horticulturist; otherwise the land may be left in its natural state and enhanced with the addition of trees and shrubs.*
- g. *Any future rezoning to HTD may be conditioned so that the goals and intent of the Comprehensive Plan and Article V., Section I.1. of the Zoning Ordinance are achieved.*
- h. *For the purposes of Article IV, Section B.2.b. and the screening requirements of the City of Fairhope Tree Ordinance, the Highway Transitional District shall be considered commercial/business regardless of use.*

2. **THAT**, Article III, Section B. Table 3-1: Use Table, be hereby amended to add a column to read as follows:

*HTD*

*Uses Permitted subject to general ordinance standards and conditions: Single-family, Two-family, Townhouse, Mixed-use, Elementary School, Secondary School, Education Facility, Library, Public Open Space, Common Open Space, General Office, Professional Office, Day Care, and Bed & Breakfast.*

*Uses Permitted subject to special conditions listed in the ordinance: Accessory Dwelling, Home Occupation, and Convenience Store.*

*Uses Permitted only on appeal and subject to special conditions: Multiple-family/Apartment, Place of Worship, Cemetery, Hospital, Community Center or Club, Public Utility, General Merchandise, Outdoor Sales Limited, Garden Center, Convalescent or Nursing Home, Clinic, Outdoor Recreation Facility, Mortuary or Funeral Home, and Limited Manufacturing.*

3. **THAT**, Article III, Section B. Table 3-2: Dimension Table, be hereby amended to add a row to read as follows:

*HTD – See Article V., Section I.*

Ordinance No. \_\_\_\_\_  
Page -3-

**Severability Clause** - if any part, section or subdivision of this ordinance shall be held unconstitutional or invalid for any reason, such holding shall not be construed to invalidate or impair the remainder of this ordinance, which shall continue in full force and effect notwithstanding such holding.

**Effective Date** – This ordinance shall take effect immediately upon its due adoption and publication as required by law.

Adopted and approved this 22nd day of February, 2021.

By: \_\_\_\_\_  
Jack Burrell, Council President

Attest:

By: \_\_\_\_\_  
Lisa A. Hanks, MMC  
City Clerk

Adopted and approved this 22nd day of February, 2021.

By: \_\_\_\_\_  
Sherry Sullivan, Mayor

ORDINANCE NO. \_\_\_\_

AN ORDINANCE AMENDING ORDINANCE NO. 1253  
KNOWN AS THE ZONING ORDINANCE

BE IT ORDAINED BY THE CITY COUNCIL OF THE CITY OF FAIRHOPE, ALABAMA as follows:

The ordinance known as the Zoning Ordinance (No. 1253), adopted 27 June 2005, together with the Zoning Map of the City of Fairhope, be and the same hereby is changed and altered in respect to that certain property described below:

After the appropriate public notice and hearing of the Planning Commission of the City of Fairhope, Alabama has forwarded a **favorable** recommendation,

The property of Seaman Capital, LLC/Dominion Partners generally located southwest of the intersection of Greeno Rd and Volanta Ave, Fairhope, Alabama.

**The Reserve at Fairhope PUD**

**PPIN # 386193 & 386197**

**Legal Description:** (Case number ZC 20.09)

PARCEL A:

COMMENCING AT THE SOUTHEAST CORNER OF FRACTIONAL SECTION 39, TOWNSHIP 6 SOUTH, RANGE 2 EAST, BALDWIN CONTY, ALABAMA; THENCE NORTH 00°04'55" EAST A DISTANCE OF 1320.20 FEET TO A POINT; THENCE NORTH 89°57'54" WEST A DISTANCE OF 660.83 FEET TO A POINT MARKED BY A 4-INCH SQUARE CONCRETE MONUMENT; THENCE NORTH 00°12'06" WEST A DISTANCE OF 659.76 FEET TO A POINT MARKED BY A CONCRETE MONUMENT ACCEPTED AS THE BEING THE SOUTHEAST CORNER OF THE NORTHWEST QUARTER OF THE NORTHEAST QUARTER OF THE SOUTHEAST QUARTER OF SAID FRACTIONAL SECTION 39 FOR THE POINT OF BEGINNING OF THE PROPERTY HEREIN DESCRIBED; THENCE NORTH 03°34'56" WEST A DISTANCE OF 374.46 FEET TO A POINT MARKED BY AN OPEN TOP IRON PIPE; THENCE NORTH 00°42'10" EAST A DISTANCE OF 242.13 FEET TO A POINT MARKED BY AN "X" CHISELED IN THE SIDEWALK ON THE SOUTH MARGIN OF VOLANTA AVENUE; THENCE ALONG SAID SOUTH MARGIN SOUTH 89°42'39" EAST A DISTANCE OF 513.59 FEET TO A POINT MARKED BY A CONCRETE MONUMENT WITH A DISC ON THE WEST MARGIN OF U.S. HIGHWAY 98 (A.K.A. GREENO ROAD); THENCE DEPARTING SAID SOUTH MARGIN AND ALONG SAID WEST MARGIN SOUTH 30°29'55" EAST A DISTANCE OF 65.01 FEET TO A POINT ON A NON-TANGENTIAL 1,881.75' RADIUS CURVE TO THE RIGHT, SAID POINT MARKED BY A CONCRETE MONUMENT WITH A DISC; THENCE ALONG SAID WEST MARGIN AND THE ARC OF SAID CURVE A DISTANCE OF 437.19 FEET (CHORD BEARS SOUTH 07°05'50" EAST, 436.21') TO A POINT MARKED BY A CONCRETE MONUMENT WITH A DISC; THENCE ALONG SAID WEST MARGIN SOUTH 01°25'33" EAST A DISTANCE OF 292.42 FEET TO A POINT MARKED BY A CONCRETE MONUMENT; THENCE ALONG SAID WEST MARGIN SOUTH 00°22'16" EAST A DISTANCE OF 461.88 FEET TO A POINT MARKED BY A CONCRETE MONUMENT WITH A DISC ON THE NORTH MARGIN OF HOYLE AVENUE; THENCE DEPARTING SAID WEST MARGIN AND ALONG SAID NORTH MARGIN NORTH 89°58'22" WEST A DISTANCE OF 258.04 FEET TO A POINT MARKED BY A CAPPED IRON ROD (REBAR); THENCE DEPARTING SAID NORTH MARGIN NORTH 00°13'45" WEST A DISTANCE OF 630.97 FEET TO A POINT MARKED BY AN IRON ROD (REBAR); THENCE SOUTH 89°46'55" WEST A DISTANCE OF 329.75 FEET TO THE POINT OF BEGINNING; CONTAINING 515,824 SQUARE FEET (11.84 ACRES) MORE OR LESS.

PARCEL B:

THE WEST HALF OF THE SOUTHEAST QUARTER OF THE NORTHEAST QUARTER OF THE SOUTHEAST QUARTER, BEING BLOCK 10 OF THE SUBDIVISION OF THE SOUTHEAST QUARTER OF FRACTIONAL SECTION 39, TOWNSHIP 6 SOUTH, RANGE 2 EAST, BALDWIN COUNTY, ALABAMA, MORE PARTICULARLY DESCRIBED AS FOLLOWS:

COMMENCING AT THE SOUTHEAST CORNER OF FRACTIONAL SECTION 39, TOWNSHIP 6 SOUTH, RANGE 2 EAST, BALDWIN COUNTY, ALABAMA; THENCE NORTH 00°04'55" EAST A DISTANCE OF 1320.20 FEET TO A POINT; THENCE NORTH 89°57'54" WEST A DISTANCE OF 660.83 FEET TO A POINT MARKED BY A 4-INCH SQUARE CONCRETE MONUMENT; THENCE NORTH 00°30'13" WEST A DISTANCE OF 29.56 FEET TO A POINT MARKED BY A CAPPED IRON ROD (REBAR) FOR THE POINT OF BEGINNING OF THE PROPERTY HEREIN DESCRIBED; THENCE NORTH 00°11'15" WEST A DISTANCE OF 630.20 FEET TO A POINT MARKED BY A CONCRETE MONUMENT ACCEPTED AS THE BEING THE SOUTHEAST CORNER OF THE NORTHWEST QUARTER OF THE NORTHEAST QUARTER OF THE SOUTHEAST QUARTER OF SAID FRACTIONAL SECTION 39; THENCE NORTH 89°46'55" EAST A DISTANCE OF 329.75 FEET TO A POINT MARKED BY AN IRON ROD (REBAR); THENCE SOUTH 00°13'45" EAST A DISTANCE OF 630.97 FEET TO A POINT MARKED BY A CAPPED IRON ROD (REBAR) ON THE NORTH MARGIN OF HOYLE AVENUE; THENCE ALONG SAID NORTH MARGIN AND THE WESTWARD EXTENSION THEREOF SOUTH 89°54'51" WEST A DISTANCE OF 330.20 FEET TO THE POINT OF BEGINNING; CONTAINING 208,077 SQUARE FEET (4.78 ACRES) MORE OR LESS.

1. **That**, attached as "Exhibit A" is an approved site plan. The property must develop in substantial conformance with the approved site plan and supporting documents. Any substantial deviation from the attached site plan, as determined by the Director of Planning, will require re-approval by the Planning Commission and the City Council of the City of Fairhope, Alabama, as a PUD amendment.
2. **That**, attached as "Exhibit B" is an approved Master Development Plan. The property must develop in substantial conformance with the approved site plan and supporting documents. Any substantial deviation from the attached site plan, as determined by the Director of Planning, will require re-approval by the Planning Commission and the City Council of the City of Fairhope, Alabama, as a PUD amendment.
3. **That**, the following development regulations shall govern:

Lots: There shall be one lot approximately 16.62 acres.

Use: In general, the project is restricted for senior housing. The uses are specifically described within the Site Data Table and Master Development Plan that include:

- |    |  |
|----|--|
| 10 | Duplex Villas consisting of 20 Units Total           |
| 1  | 3-Story Building Consisting of 168 Units to include: |
|    | 32-Memory Care Units                                 |
|    | 32-Assisted Living Units                             |
|    | 84-Independent Living Units                          |

Dimension Standards: Dimensional standards shall follow the layout on the approved site plan.

Building Height: The maximum eave height for the approved 3-story building shall be 34'.

Landscape: Tree Removal and Landscape shall be reviewed by the City of Fairhope Tree Commission.

Ordinance No. \_\_\_\_\_  
Page -3-

Pedestrian Circulation: Sidewalks and trails will be included as shown on the approved site plan. A signalized crosswalk across Volanta Ave will be installed by the developer and coordinated with the City of Fairhope's Public Works Department.

Drainage and Detention: Drainage and detention shall meet the Stormwater Standards in the Fairhope Subdivision Regulations.

Buffers: Buffers shall meet the applicable requirements of all City of Fairhope Regulations.

**The property is hereby rezoned from R-1 Low Density Single Family Residential District to Planned Unit Development (PUD).** This property shall hereafter be lawful to construct on such property any structures permitted by Ordinance No. 1253 and to use said premises for any use permitted or building sought to be erected on said property shall be in compliance with the building laws of the City of Fairhope and that any structure shall be approved by the Building Official of the City of Fairhope and that any structure be erected only in compliance with such laws, including the requirements of Ordinance No. 1253.

**Severability Clause** - if any part, section or subdivision of this ordinance shall be held unconstitutional or invalid for any reason, such holding shall not be construed to invalidate or impair the remainder of this ordinance, which shall continue in full force and effect notwithstanding such holding.

**Effective Date** – This ordinance shall take effect immediately upon its due adoption and publication as required by law.

Adopted and approved this 22nd day of February, 2021.

By: \_\_\_\_\_  
Jack Burrell, Council President

Attest:

By: \_\_\_\_\_  
Lisa A. Hanks, MMC  
City Clerk

Adopted and approved this 22nd day of February, 2021.

By: \_\_\_\_\_  
Sherry Sullivan, Mayor

# City of Fairhope Planning Commission

December 7, 2020



## ZC 20.09 - The Reserve at Fairhope

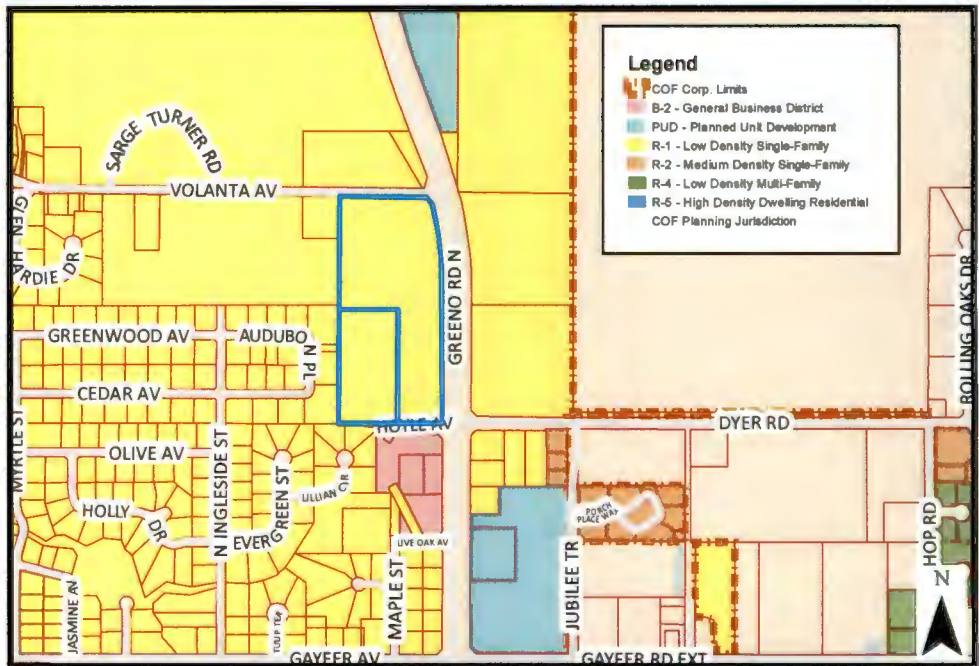
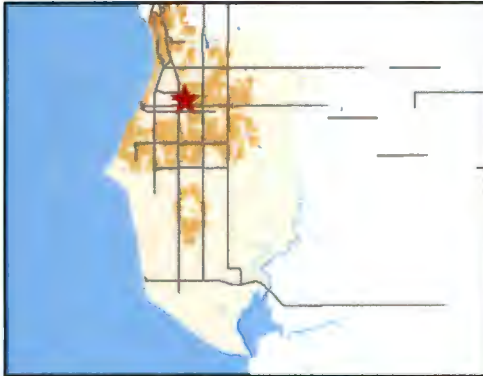

**Project Name:**

The Reserve at Fairhope PUD

**Site Data:**

16.62 Acres

**Project Type:**

168 Unit Senior Living Community

**Jurisdiction:**

Fairhope Planning Jurisdiction

**Zoning District:**

R-1

**PPIN Number:**

386193 & 386197

**General Location:**

SW Intersection of Greeno Rd and Volanta Ave

**Surveyor of Record:**

Hunter Smith, Smith, Clark & Associates

**Engineer of Record:**

Trey Jinright, Jade Consulting, LLC

**Owner / Developer:**

Seaman Capital LLC/Dominion Partners

**School District:**

Fairhope West Elementary School;  
Fairhope Middle and High Schools

**Recommendation:**

Approve w/ Conditions

**Prepared by:**

Hunter Simmons





**Summary of Request:**

The applicant is requesting to rezone the subject property from R-1, Single Family Residential District to PUD, Planned Unit Development. The property is approximately 16.62 acres and is located at the SW intersection of Greeno Rd and Volanta Ave.

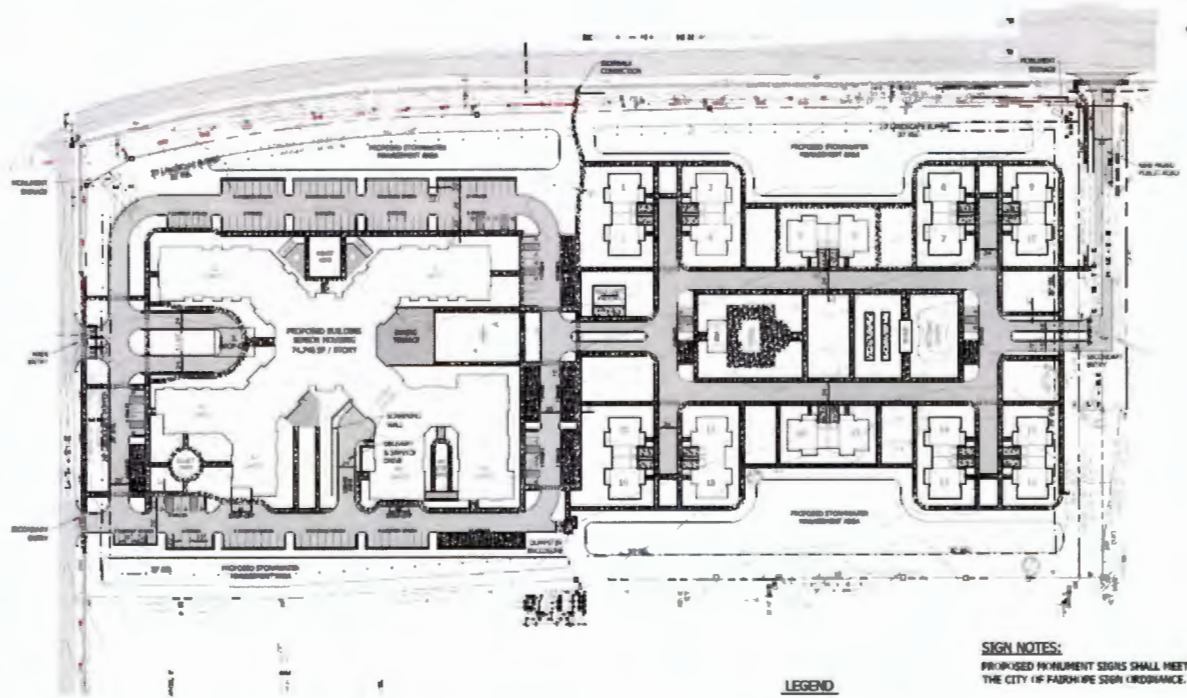

The applicant describes the project as a “senior living community” that “provides varying degrees of care for citizens 55 years of age and older”. The project consists of 168 total units; 104 independent living units, 32 assisted living units, and 32 memory care units. 20 of the independent living units will be patio homes, with the remainder of the units contained in a proposed 3 story, approximately 225,000 s.f. building. Per the site data table, the net density of the project is 12.6 Units/Ac.

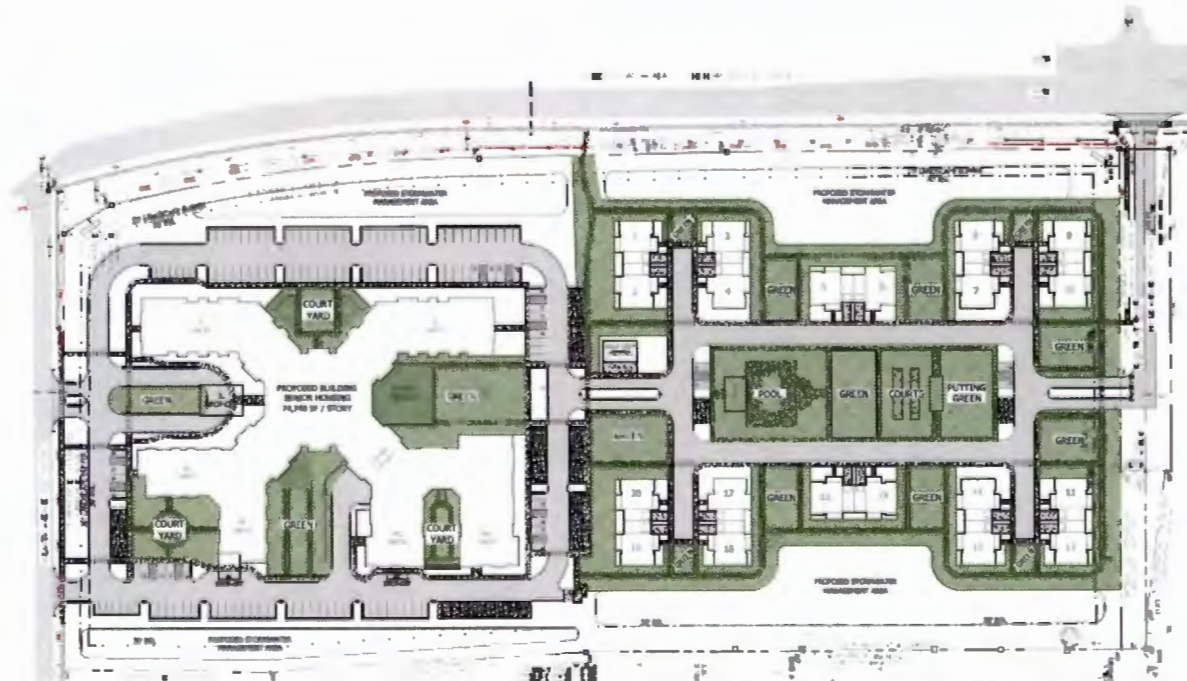

The project proposes over 26% (25% required) of the 16.62 acres as greenspace with amenities that include a pool, courts, a putting green, court yards, as well as “activity trials”. In addition to the greenspace shown in the plan above, a 20’ buffer is providing adjacent to Greeno Rd and Volanta Ave.

**Comments:**

Questions regarding development along Greeno Rd, especially outside of the village centers, have been debated for years. Many properties are zoned R-1 – Single-Family Residential. If R-1 is no longer viable along a state highway, what options are available for these properties? While dense, this proposed project captures the intent of our PUD zoning – it is comprehensively plan, innovative use of the site, offers variety of living opportunities, and makes efficient use of greenspace.

Not all questions will be answered in this review. Traffic, detailed drainage plans, electrical, and sewer services will need to be reviewed in detail. If approved, this project will trigger the Multiple Occupancy Project (MOP) regulations of the City of Fairhope’s Subdivision Regulations. During that review, staff, as well as the Planning Commission will provide a critical review of those technical systems.

***Criteria – The application shall be reviewed based on the following criteria:***

***(1) Compliance with the Comprehensive Plan;***

**Response:**

*Per the Applicant:*

The project complies with the form, function, and design recommendations along Greeno Road found in the City of Fairhope Comprehensive Plan. The proposed land use offers a good transition from more intense commercial uses to the south, the public park uses to the north, and the existing residential uses to the west along Volanta. The project will include pedestrian features and landscape buffers along both Greeno and Volanta. The main building placement was selected to provide the proper accessibility needed for the proposed land use, but not crowd the buffers and pedestrian connection points. The location of Volanta Park across the street from the proposed project also provides a nice way for the elderly to fit into the community by mixing with the youth at the park.

Staff believes the proposed use is a great fit for the subject property. Not only does it align with the goals of the comprehensive plan, but the location geographically links elderly residents with an integral piece of Fairhope’s social infrastructure – Volanta Park.

***(2) Compliance with the standards, goals, and intent of this ordinance;***

**Response:**

The purpose of the PUD District is intended to encourage opportunities for development innovation tailored to a particular site, which while clearly furthering the goals of the comprehensive plan, could not explicitly be established by generally applicable standards or guidelines. The proposed project meets the intent of a PUD.

***(3) The character of the surrounding property, including any pending development activity;***

**Response:** The City of Fairhope’s desire for Greeno Road to become something other than a run-of-the-mill commercial strip is address by the design of the proposed project. While the buildings are setback from the road, ample greenspace is provided to, effectively, create a screen. Prior to an MOP review, staff will request the Tree Commission review the Landscape Plan.

Architectural standards are provided within the Master Development Plan. Below are a few images from the taken from the Master Development Plan.

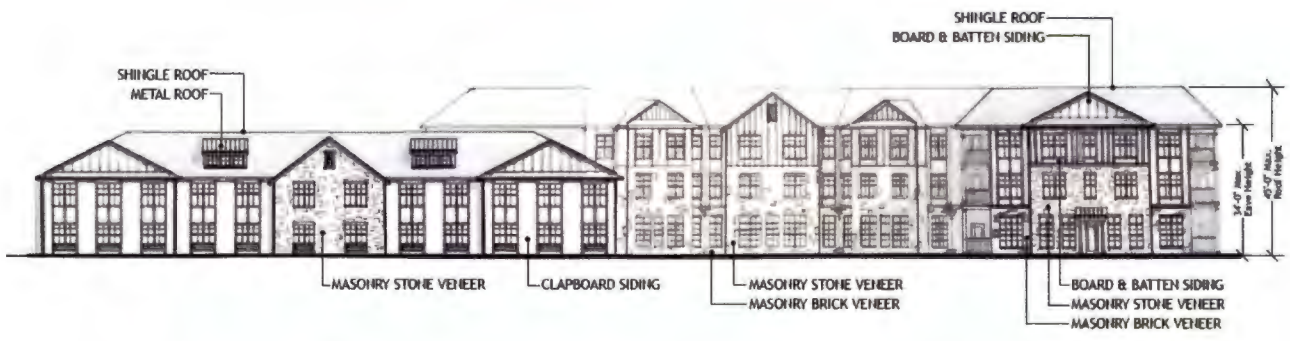
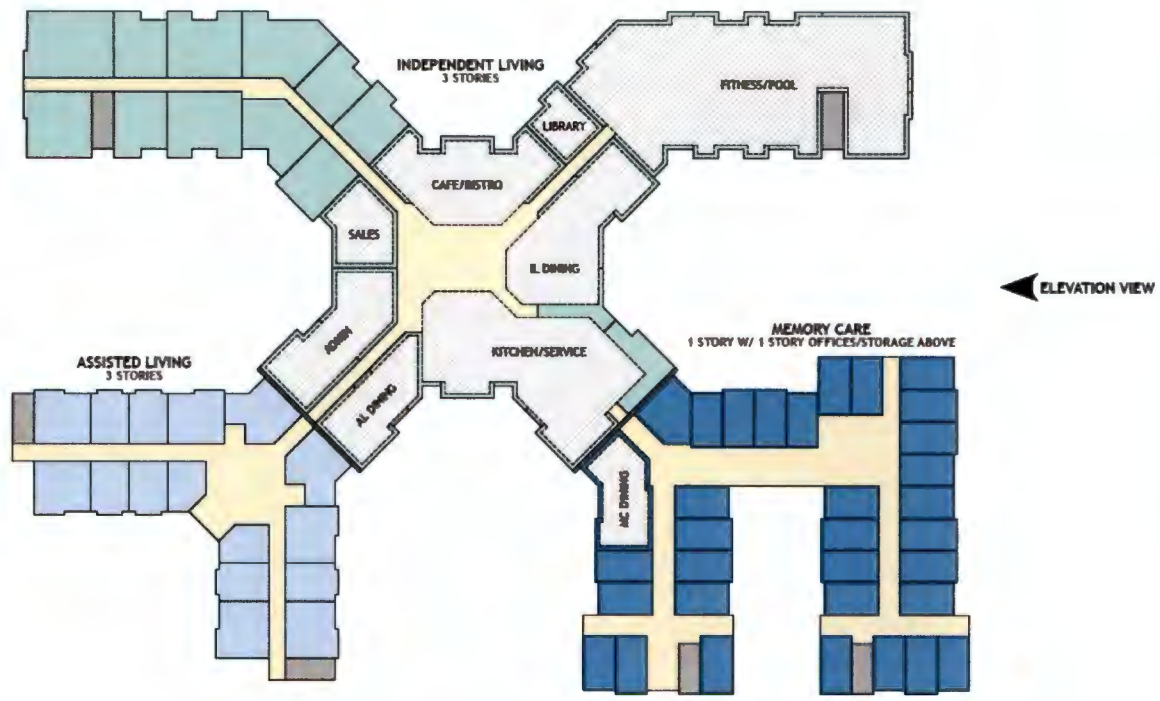

***(4) Adequacy of public infrastructure to support the proposed development;***

**Response:** There are some challenges providing sewer and electrical to the site at the scale needed for this project. Both utility departments, as well as the applicant, are aware of the challenges and working toward a solution. Plans will be presented during MOP review.

***(5) Impacts on natural resources, including existing conditions and ongoing post-development conditions;***

**Response:** A tree inventory/removal plan is included within the packet. Several heritage trees are being preserved. 58 trees are proposed to be removed and replaced with 181 trees.

***(6) Compliance with other laws and regulations of the City;***

**Response:** At the time of development all applicable laws of the City will be applied.

***(7) Compliance with other applicable laws and regulations of other jurisdictions;***

**Response:** At the time of development all applicable laws of the City will be applied.

***(8) Impacts on adjacent property including noise, traffic, visible intrusions, potential physical impacts, and property values; and,***

**Response:** Staff does not anticipate any significant issues relating to these criteria. A traffic study shall be required for all applications that will generate an average daily traffic (ADT) count of 1,000 trips or more, or which will generate 50 trips or more during any peak hour period and will be a requirement during the MOP review.

Internal lighting will not impact adjacent neighbors. Per the Master Development Plan the lighting package shows a 0.0 foot-candle reading around the perimeter of the property.

A wetland delineation report is provided within the Master Development Plan. No jurisdictional wetlands were found on site. During the field inspection, no hydric soil indicators were found, no wetland hydrologic indicators were noted, and it was determined the entire parcel is comprised of uplands.

***(9) Impacts on the surrounding neighborhood including noise, traffic, visible intrusions, potential physical impacts, and property values.***

**Response:** Staff anticipates more pedestrians crossing Volanta Ave to access the Recreation Center/Parks. There is an existing crosswalk south of the subject property, but there are currently no signals. The applicant, at their cost, has agreed to install crosswalk signals, which shall be approved by the City of Fairhope's Public Works Department.

**Staff Recommendation:**

Staff recommends Case: ZC 20.09 *The Reserve at Fairhope* PUD from R-1 to PUD be **Approved with the following conditions:**

1. Tree removal and landscape plans shall be reviewed by the City of Fairhope Tree Commission prior to MOP submission.
2. The proposed signalized crossing shall be coordinated with The City of Fairhope's Public Works Department.
3. Final drainage plans, as well as connectivity to Sewer and Electrical, will be resolved during MOP review.

4. A traffic study and building elevations will be provided for review as part of the M.O.P. application.

**Planning Commission Recommendation:**

Art Dyas made a motion to accept the staff recommendation for **APPROVAL** to the Fairhope City Council to rezone subject properties from R-1 to PUD with the following conditions:

1. Tree removal and landscape plans shall be reviewed by the City of Fairhope Tree Commission prior to/during M.O.P. review.
2. The proposed signalized crossing shall be coordinated with The City of Fairhope's Public Works Department.
3. Final drainage plans, as well as connectivity to Sewer and Electrical, will be resolved prior to/during M.O.P. review.
4. A traffic study and building elevations will be provided for review as part of the M.O.P. application.

Harry Kohler 2<sup>nd</sup> the motion and the motion carried unanimously with the following vote: AYE – Art Dyas, Rebecca Bryant, Harry Kohler, Lee Turner, Hollie MacKellar, Jason Langley, Clarice Hall-Black, and Jimmy Conyers. NAY – none.

GREENO ROAD - AKA U.S. HIGHWAY 98 (160' R.O.W.)

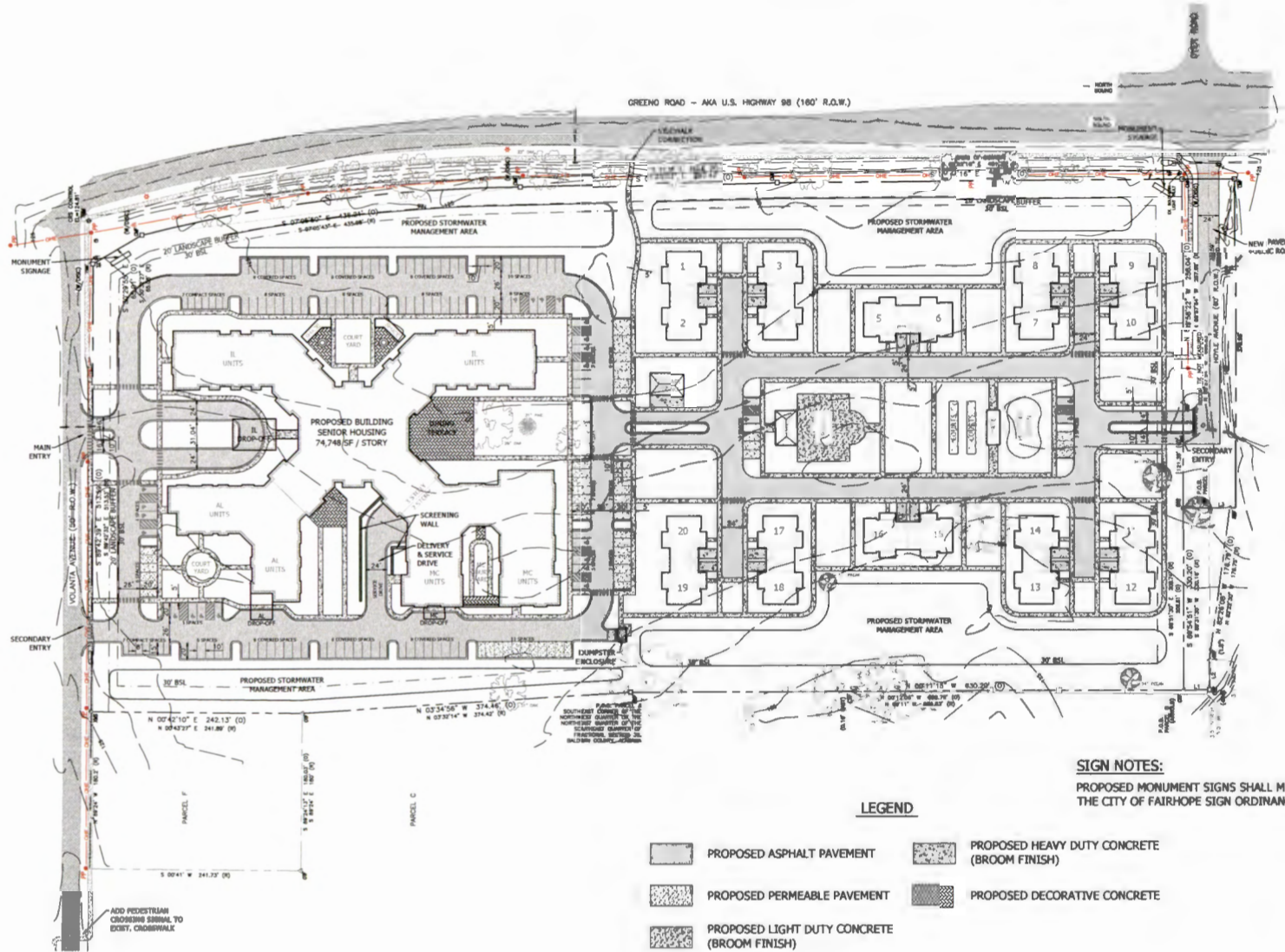

SITE DATA TABLE	
STATE OF ALABAMA COUNTY OF BALDWIN CITY OF FAIRHOPE	
TAX PARCEL ID:	05-46-03-29-0-002-003.001 05-46-03-29-0-002-003.004
PARCEL SIZE:	16.62 AC
EXISTING ZONING:	R-1, LOW DENSITY SINGLE-FAMILY
PROPOSED ZONING:	PUD
PUD ACREAGE:	16.62 AC
<b>FRONT:</b> 30'	
<b>SIDE &amp; STREET SIDE:</b> 30'	
<b>REAR:</b> 30'	
<b>BUILDING HEIGHT:</b> MAX. 3rd FLOOR HEIGHT	
<b>BUILDING COVERAGE:</b> MAX. 20% (3.32 AC)	
<b>IMPERV. COVERAGE (INC. BLDGS):</b> MAX. 40% (7.08 AC)	
<b>SENIOR HOUSING:</b> 148 TOTAL UNITS / 74,748 SF / STORY	
3 STORY - INDEPENDENT LIVING: 84 UNITS (56% OF TOTAL)	
3 STORY - ASSISTED LIVING: 32 UNITS (22% OF TOTAL)	
1 STORY - MEMORY CARE: 32 UNITS (22% OF TOTAL)	
<b>DUPLEX VILLAGES:</b> 20 UNITS / 3,150 SF / UNIT (EXCLUDES GARAGE)	
<b>NET DENSITY:</b> 168 UNITS / 16.62 AC = 12.6 UNIT/AC	
<b>SENIOR HOUSING VEHICLE PARKING:</b> 1 SPACE / 4 BEDS, PLUS 1 SPACE / 4 EMPLOYEES = 34 SPACES (INC. 20 HVC)	
<b>VILLAGES VEHICLE PARKING:</b> 1 SPACE / UNIT = 20 SPACES (INC. 4 HVC)	
<b>SIDEWALK WIDTH:</b> MIN. 5' WIDTH	
<b>PARKING SPACES:</b> 10'x20'	
<b>COMPACT PARKING SPACES:</b> 8'x11'	
<b>DRIVE AISLE (SENIOR HOUSING):</b> 26' WIDE	
<b>DRIVE AISLE (DUPLEX):</b> 34' WIDE	

**SIGN NOTES:**  
PROPOSED MONUMENT SIGNS SHALL MEET THE CITY OF FAIRHOPE SIGN ORDINANCE.

**LEGEND**

- PROPOSED ASPHALT PAVEMENT
- PROPOSED HEAVY DUTY CONCRETE (BROOM FINISH)
- PROPOSED PERMEABLE PAVEMENT
- PROPOSED DECORATIVE CONCRETE
- PROPOSED LIGHT DUTY CONCRETE (BROOM FINISH)

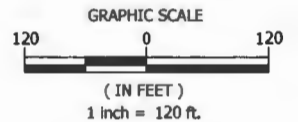

**CONCEPTUAL SITE PLAN**  
THE RESERVE AT FAIRHOPE  
PLANNED UNIT DEVELOPMENT  
GREENO ROAD & VOLANTA AVE:  
FAIRHOPE, AL

**Application For:**

PUD Rezoning Request

For

**The Reserve at Fairhope**

A Planned Unit Development

November 18, 2020

**Applicant:**

**DOMINION**  
— P A R T N E R S —

Dominion Senior Living of Fairhope, LLC  
1200 Corporate Drive | Suite 225  
Birmingham, AL 35242

**Prepared by:**

The logo for JADE CONSULTING features a stylized 'J' and 'A' in blue and green, followed by 'ADE' in large black letters, and 'CONSULTING' in smaller black letters below.

**• DEVELOPMENT ENGINEERS •**

208 Greeno Road North, Suite C  
Post Office Box 1929  
Fairhope, Alabama 36533  
Telephone: 251-928-3443 • Fax: 251-928.3665

**Table of Contents**

Table of Contents ..... 1

List of Appendices ..... 1

Project Team and Contact Information ..... 2

Project Narrative ..... 3

    Independent Living (IL): ..... 3

    Assisted Living (AL): ..... 3

    Memory Care (MC): ..... 3

    Age-in-Place: ..... 4

    Services and Amenities ..... 4

    Site Description: ..... 5

    Employees: ..... 6

    Construction: ..... 6

Architectural Narrative: ..... 6

**List of Appendices**

- Appendix A    Company Profile
  - 1. Articles of Incorporation
- Appendix B    Zoning Application
  - 1. Legal
  - 2. Warranty Deed
  - 3. Owner's Authorization
- Appendix C    Neighborhood Meeting Notice
  - 1. Adjacent Property Owner list
  - 2. Map
  - 3. Certified Mail Receipts
  - 4. Sign-In Sheet
  - 5. Comments Sheets (There were no comment sheets completed)
- Appendix D    Certification of Property Owners
  - 1. List of Property Owner Withing 300'
  - 2. Map
  - 3. 5160 Labels
- Appendix E    Wetland Delineation Report
- Appendix F    11 x 17:
  - 1. Boundary and Topographic Survey
  - 2. Vicinity Map & Underlying Zoning
  - 3. Comparative Zoning Tables
  - 4. Conceptual Site Plan
  - 5. Conceptual Greenspace Plan
  - 6. Architectural Composite Floor Plan
  - 7. Architectural Building Elevation
  - 8. Architectural Rendered Building Elevation
  - 9. Photometric Plan & Lighting Specification
  - 10. Tree Preservation and Removal Plan
  - 11. Landscape Plan



**Project Team and Contact Information**

<p>Developer/Buyer:</p> 	<p><b>Dominion Senior Living of Fairhope, LLC</b>                  1200 Corporate Drive   Suite 225                  Birmingham, AL 35242                  205.776.6086</p> <p>R. Withers Poellnitz  <a href="mailto:wpoellnitz@dpllc.com">wpoellnitz@dpllc.com</a></p>
<p>Owner/Seller:</p>	<p>Seaman Capital LLC                  3 Cherry Hills                  Shoal Creek, AL 35242</p>
<p>Civil Engineer:</p> 	<p><b>JADE Consulting, LLC</b>                  208 N. Greeno Rd., Ste. C                  Fairhope, AL 36532                  (251) 928-3443</p> <p>Perry C. "Trey" Jinright III, P.E., LEED AP  <a href="mailto:tjinright@jadengineers.com">tjinright@jadengineers.com</a></p> <p>Lee Rambo, Designer  <a href="mailto:Lrambo@jadengineers.com">Lrambo@jadengineers.com</a></p> <p>Sherry Ruth, Project Coordinator  <a href="mailto:sruth@jadengineers.com">sruth@jadengineers.com</a></p>
<p>Surveyor:</p> 	<p><b>Smith, Clark &amp; Associates, LLC.</b>                  P.O. Box 7082                  Spanish Fort, AL 36577                  Office: (251) 626-0404</p> <p>Hunter C. Smith, P.L.S.  <a href="mailto:hunter@smithclarkllc.com">hunter@smithclarkllc.com</a></p>
<p>Architect:</p> 	<p><b>Niles Bolton Associates</b>                  3060 Peachtree Rd NW                  Suite 600                  Atlanta, GA 30305                  404.365.7600</p> <p>Teresa Nguyen  <a href="mailto:tnguyen@nilesbolton.com">tnguyen@nilesbolton.com</a></p>
<p>Landscape Architect:</p> 	<p>WAS Design, Inc.                  218 N. Alston St.                  Foley, Alabama 36535                  (251) 948-7181</p> <p>Van Webb  <a href="mailto:vwebb@was-design.com">vwebb@was-design.com</a></p>

**Project Narrative**

The proposed project is a luxury senior living community consisting of 168 total units on approximately 16.62 acres. A "senior living community" is a general term for the different types of housing providing varying degrees of care for seniors 55 years of age and older. In Dominion Partners' previous developments, however, the average age of new residents is approximately 82 years old.

Senior living communities are designed to suit a variety of lifestyles and provide a range of assistance including independent living, assisted living, and specialty care assisted living, commonly known as "memory care." In order to provide a full continuum of care and a true "age in place" community, the proposed project will offer 104 independent living (IL) units, 32 assisted living (AL) units, and 32 memory care (MC) units. As the site plan shows, approximately 50% of the land will be used for 20 IL patio homes on the southern end of the property, and the northern half will hold the "main building" that contains 84 IL residences and the assisted living and memory care residences. All of the units, including the patio homes, will be for rent only and not for sale. Medicare and Medicaid do not provide rental assistance for any category of living in these types of communities. Instead, all of the residents use personal disposable income, applicable long-term care insurance, or wealth to make rental payments each month.

The purpose and intent of senior living is to enable seniors to maintain as much independence, individuality and autonomy as possible, provide them with support and assistance when they need it, and enhance their lifestyle, dignity and joy of life. One of the major benefits offered by luxury senior living communities is an active, socially engaging lifestyle. Engaging in social activities and group events while learning new skills enables seniors to bond with new friends while promoting physical and mental health. Residences available at the property will include three types:

***Independent Living (IL):***

Independent living is specifically designed for more active, self-reliant seniors who desire a maintenance-free lifestyle and the social benefits of living in a community with other seniors. Although most of the seniors who live in an IL setting require little if any assistance or daily care, supportive services are available around the clock and provided in emergency situations. Unlike AL and MC units, IL units do not require a state license to operate.

***Assisted Living (AL):***

Assisted living is offered to seniors who need help with one or more activities of daily living (ADLs) such as medication administration, meal preparation and dining, bathing, dressing, mobility, and toileting. State licensure from the Alabama Department of Public Health is required to provide AL services to appropriate residents and a licensed administrator, certified nurses, and trained staff provide care and assistance.

***Memory Care (MC):***

Memory care is available to residents who require cognitive support due to dementia. The entire memory care residence and outdoor courtyard are secure and monitored to ensure resident safety. State licensure and a Certificate of Need (CON) are required for every memory care resident unit in the project.

As previously stated, a Certificate of Need (CON) is required for every Memory Care bed in the project and must be approved by the State Health Planning and Development Agency (SHPDA). A Letter of Intent (LOI) to apply for the beds has been filed for this project, and there are no other applicants filing in the same "batch" (a batch is what SHPDA calls it when two or more entities are applying for beds at the same time in the same county) for additional beds in Baldwin County. Since no competitors are applying for Memory Care beds in our "batch", the likelihood of receiving the CON for all 32 Memory Care beds very likely. In addition, SHPDA updated the Alabama State Health Plan in May 2020 which added 338 Memory Care beds in Baldwin County alone. To put this in perspective, before the Alabama State Health Plan was updated Baldwin County only had 184 total Memory Care beds. As soon as the property is zoned correctly to develop the Memory Care beds, a formal CON application will be filed. Dominion estimates it will take approximately 120 days from filing a formal application to receiving final approval.

**Age-in-Place:**

Following the age-in-place model, a resident could first move into one of the patio homes, which is typically occupied by the more active senior or couple. When the resident becomes a little less active, has more limited mobility, or simply prefers the more communal atmosphere, he or she may choose to move into one of the IL residences in the main building to be closer to dining, activities, and other amenities. Eventually the resident may require assistance with ADLs, so he or she could move into an AL residence. If cognitive assistance and support are required, the resident could move into one of the MC units. Should one spouse require additional care, the independent spouse will have the comfort and convenience of being nearby in the same community. Trained staff interact with all residents regularly and frequently, developing relationships and trust with them and their families. These relationships help make transitions within the community smoother, more natural, and less stressful for the resident and family.

Architecturally and operationally, senior living communities include a plethora of features that make them truly unique developments. The buildings must be designed and operated for a multitude of uses including residential, healthcare, dining, hospitality, and even a little bit of country club. Due to the complexities of the overall design and operations of a luxury senior living community, the staffing that is required is significant. The staff can be broken into a handful of subgroups:

- Administration – Executive Director and Financial Services
- Marketing – Includes Director of Sales and Marketing and staff
- Resident Services – Resident Services Director, Lifestyle Director, Fitness Coordinator, Transportation, Concierge, Security Officer and other staff employees that help fill the residents' schedule with activities
- Healthcare – Nurses, Med-Techs, and Care Associates
- Dining – Cooks, Servers, and Kitchen Staff
- Environmental Services – Housekeepers and Engineers/Maintenance Techs

**Services and Amenities**

The services and amenities provided in these communities promote wellness, socialization, a high quality of life, convenience, mental stimulation, spiritual expression, artistic exploration, and entertainment in senior-friendly surroundings. Although most of the amenities for this project are located in the main building, all residents, including the cottage residents, are encouraged to use and participate in any of the amenities or services that are offered. Some of the services and amenities available to all residents that will be included in the proposed project include:

- 24-hour emergency response system with on-site monitoring and daily check in
- Access to on-site physical, occupational and speech therapy
- Licensed nurse on-site 24 hours a day, seven days a week for AL and MC
- Innovative lifestyle programming providing social, educational, fun and healthy activities, events and outings
- Scheduled transportation to area shopping and local appointments
- Medication assistance and management for AL and MC
- Luxuriously landscaped and well-appointed outdoor spaces with paved walking paths throughout
- Fitness center with indoor aerobic exercise pool
- Outdoor swimming pool
- Courtyards, village greens, and lawn games
- Patios or balconies in most IL and AL apartments
- Luxury finishes and fixtures

- Weekly cleaning and laundry service
- White-linen upscale and laid-back casual dining experiences
- Salon/Barbershop offering hair styling, manicure and pedicure services
- Movie theater
- Library and computer center
- Concierge service

Due to the varying levels of care and assistance required among the three categories of residents, it is operationally safer and more efficient to design the building with "wings" that cater to the specific needs of each resident in the least restrictive and most beneficial environment. This provides numerous advantages including but not limited to these:

- The MC wing and courtyard are secure and monitored to prohibit residents from wandering
- Nurse stations in the AL and MC wings are optimally located for close proximity to each unit and resident
- Resident drop-off areas are strategically located within sight and easy reach of staff in case the resident needs assistance getting from the car to the facility
- Dining venues are intentionally designed for each wing to provide comfortable and elegant meal experiences
- Outdoor courtyards conducive to the needs of each resident type are situated at easily accessible locations
- In Dominion Partners' previous developments, the central area of the main building is the hub of activity for the community at large, providing features, services and amenities for all residents to enjoy.

***Site Description:***

The location of the subject property is perfect for a senior living community. Easy access to doctors' offices and medical care is important to seniors and senior living communities; with Thomas Hospital approximately 1.25 miles south of the site, medical care is very convenient. The Fairhope Recreation Center at Volanta Park is directly across Volanta Avenue, which is also a convenient feature of the property. This situation is similar to a senior community Dominion developed next to St. Vincent's One Nineteen Health and Wellness Center in Birmingham, AL, that turned out to be a very popular and successful partnership. With a sidewalk on Volanta Avenue and a crosswalk already in place, Dominion expects and encourages the residents to enjoy everything from the indoor walking track to the pickleball courts at the Fairhope Recreation Center. In addition, the residential homes that border the west side of this site will border the portion of the property on which the one-story cottages are to be built. The main building is to be built on the east side of the property least proximal to existing residences.

The project complies with the form, function, and design recommendations along Greeno Road found in the City of Fairhope Comprehensive Plan. The proposed land use offers a good transition from more intense commercial uses to the south, the public park uses to the north, and the existing residential uses to the west along Volanta. The project will include pedestrian features and landscape buffers along both Greeno and Volanta. The main building placement was selected to provide the proper accessibility needed for the proposed land use, but not crowd the buffers and pedestrian connection points. The location of Volanta Park across the street from the proposed project also provides a nice way for the elderly to fit into the community by mixing with the youth at the park.

Senior housing communities are some of the lowest impact real estate developments there are. Traffic studies show that these communities have a much lower traffic count when compared to similar size projects on the residential or commercial side. Due to the inherent nature and habits of the residents there is no appreciable noise impact on the community. Lighting on the property is understated and purposeful;

residents keep early hours and prefer ground-focused, clear light that does not intrude into their homes or create undue glare upon approach or from within. In fact, the lighting package for the proposed project shows a 0.0 foot-candle reading around the perimeter of the property.

The project will have 176 parking spaces around the main building. In Dominion's experience, this is the amount needed to sufficiently park all residents who drive, the entire staff, and any guests of the residents. The majority of staffing shifts change during non-peak hours at 7:00 am, 3:00 pm and 11:00 pm. Cottages will each have parking for two vehicles – one in the garage and one in the driveway. While the majority of the IL residents will drive or have a car, very few if any AL residents will have a car, and no MC residents will have a car. All parking spaces and roads/drives inside the property boundary are intended to be used solely by the residents, guests of residents, and operational staff. All grounds, facilities and features will be maintained by the owner, operator, or third-party contract. Any monument signs will meet the City of Fairhope Sign Ordinance.

With golf carts becoming more and more popular in Fairhope, the site plan also includes covered golf cart parking for main building residents who still drive and own a "street legal" golf cart, and each cottage will have a tandem garage that have enough room to keep a car and a golf cart. Although a street legal golf cart is not allowed to travel along Greeno Road, the residents might enjoy driving it to the Fairhope Recreation Center, Fly Creek Marina, or even take the residential streets to downtown Fairhope.

A senior living community is an asset to the city by providing an attractive, vibrant and gracious lifestyle for its own elderly residents to enjoy. In fact, over 60% of residents in Dominion Partners' past senior living projects came from within five miles of each respective facility. The remaining residents were mostly seniors from out of town that chose to move to be near their adult children.

**Employees:**

Associates at senior living communities receive emergency training during orientation, annually, and as needed. An Emergency Policies and Procedures manual is prepared in anticipation of any emergency, and a step by step guide is followed. If an accident or illness does occur, the trained staff will evaluate whether emergency services should be called. At past projects, emergency vehicles typically pull into the IL drop-off, which in this case would be accessed directly from Volanta Avenue. Typically, the senior housing operator will establish a relationship and protocol with the local EMS that will allow the operator to tell the local EMS whether the lights and/or sirens should be active on at arrival. This helps prevent unnecessary sirens from disturbing other residents and nearby neighbors if it can be avoided.

**Construction:**

Construction is proposed and projected to begin in July 2021 and will take approximately 20 months. There will be no phasing of the construction – everything will be built at once.

**Architectural Narrative:**

The proposed senior housing project includes a total of 168 units. There will be 20 patio homes, 84 Independent living units, 32 Assisted Living units, and 32 Memory care units. The amenities and support facilities for these residents include multiple dining rooms, café, dining terraces, fitness center, library, activity rooms, common areas, indoor swimming pool, physical therapy suite, commercial kitchen, laundry facilities, etc...

The site design includes a network of walking paths, village greens, courtyards, surface parking lots, street trees, foundation plantings, swimming pool, lawn games, understated exterior/site lighting, natural landscape buffers, and storm water detention per local requirements.

The patio homes will be single story wood framed residences with private garages, front porches, and private rear patios at grade. Exteriors will include a traditional cottage/bungalow look with gabled roofs, double-hung windows, clapboard siding, masonry veneer, and neutral color palette focused on whites and greys.

The main building will be two and three stories in height with sloped roofs and gables. The architectural expression will be traditional "Arts and Crafts/Craftsman" style, at the scale of a lodge or an inn.

Exterior elements will include double-hung windows, a mix of clapboard siding and masonry veneer. The shingle roof will be sloped with hidden mechanical wells to screen condensing units and roof top equipment. Most units will have private balconies.

Service/Utility Yard and loading dock will be walled and gated. The wall will be clad in masonry to match the main building. The trash compactor will be enclosed. Ground-based condenser units will be screened and landscaped.



**APPLICATION FOR ZONING DISTRICT CHANGE**

Seller

**Property Owner / Leaseholder Information**

Name: Seaman Capital LLC Phone Number: 205-991-7200  
 Street Address: 3 Cherry Hills  
 City: Shoal Creek State: AL Zip: 35242

**Applicant / Agent Information**  
*If different from above.*  
*Notarized letter from property owner is required if an agent is used for representation.*

Name: Dominion Senior Living of Fairhope, LLC Phone Number: 205.776.6086  
 Street Address: 1200 Corporate Drive, Ste. 225  
 City: Birmingham State: AL Zip: 35242

Current Zoning of Property: R-1  
 Proposed Zoning/Use of the Property: PUD  
 Property Address: TBD Volants & Greeno  
 Parcel Number: 05-46-03-39-0-002-003.001 & 05-46-03-39-0-002-003.004  
 Property Legal Description: See attached  
 Reason for Zoning Change: See attached

- Property Map Attached  YES NO
- Metes and Bounds Description Attached  YES NO
- Names and Address of all Real Property Owners within 300 Feet of Above Described Property Attached.  YES NO

Character of Improvements to the Property and Approximate Construction Date: 1st quarter 2021  
Proposed Senior Living Facility

Zoning Fee Calculation:  
 Reference: Ordinance 1269

I certify that I am the property owner/leaseholder of the above described property and hereby submit this application to the City for review. \*If property is owned by Fairhope Single Tax Corp. an authorized Single Tax representative shall sign this application.

Dominion Senior Living of Fairhope, LLC [Signature]  
 Property Owner/Leaseholder Printed Name Signature  
9-21-20  
 Date Fairhope Single Tax Corp. (If Applicable)

Appendix E Wetland Delineation Report





October 27, 2020

Trey Jinright  
Jade Consulting Engineers  
208 N Greeno Rd STE C  
Fairhope, AL 36532

**Re: *Wetland Assessment Report  
Volanta Avenue and Greeno Road North, Baldwin County, AL  
WSI Project 2020-763***

Dear Mr. Jinright,

As requested, Wetland Sciences, Inc. has completed a field wetland assessment south of Volanta Avenue and west of Greeno Road North in Baldwin County, Alabama. The Baldwin County property appraiser identifies the property with the following parcel IDs: 05-46-03-39-0-002-003.001 and 05-46-03-39-0-002-003.004.

The purpose of performing the wetland assessment was to assess if wetlands or Waters of the United States (WOTUS) are present and, if so, to identify the boundaries. The wetland delineation was performed in accordance with the 1987 Corps of Engineers Wetlands Delineation Manual, the 2012 Regional Supplement to the Corps of Engineers Wetland Delineation Manual: Atlantic & Gulf Coast Supplement (2010). According to both U.S. Army Corps of Engineers (USACE) guidelines, wetlands generally have three essential characteristics: hydrophytic vegetation, hydric soils, and wetland hydrology.

#### **Desktop Review**

Prior to performing the delineation, several map and aerial photograph resources were reviewed to assist with identifying potential WOTUS and wetland areas at the site. Each source of data is described in detail below.

##### *Natural Resource Conservation Service Soil Survey*

WSI reviewed the Natural Resources Conservation Service (NRCS) on-line Web Soil Survey (WSS) to identify soil types in the vicinity of the site (Exhibit A). The property is comprised of Carnegie very fine sandy loam, Grady soils, Marlboro very fine sandy loam, Robertsdale loam and Savannah very fine sandy loam.

Carnegie very fine sandy loam consists of deep, well-drained soils that are medium acid or strongly acid. The soils developed in sandy clay loam to sandy clay on uplands of the Coastal Plain. Their slope ranges from 0 to 12 percent, but in most places, it is between 2 and 8 percent.

The Grady series consists of poorly drained, slowly permeable soils in upland depressions but are also along drains of the Southern Coastal Plain. These soils formed in clayey marine sediments. Typically, they are in depressions but are also along drains. Slopes range from 0 to 2 percent.

The Marlboro series consists of deep, well-drained soils that are medium acid to very strongly acid. The soils developed in thick loam and sandy clay on uplands of the Coastal Plain. Their slope ranges from 0 to 5 percent, but in most places it is between 0 to 2 percent.

Robertsdale loam consists of moderately deep, somewhat poorly drained soils that are strongly acid. The soils developed in sandy clay loam and are on uplands. Their slope is between 0 and 2 percent.

The Savannah series consists of very deep, moderately well drained, moderately slowly permeable soils on uplands and terraces in the Southern Coastal Plain. They formed in loamy marine or fluvial terrace deposits.

These soils have a hydric rating between 5 - 10% with the exception of Grady soils which have a hydric rating of 85% (Exhibit B). This rating indicates the percentage of map units that meet the criteria for hydric soils. Map units are composed of one or more map unit components or soil types, each of which is rated as hydric soil or not hydric. Map units that are made up dominantly of hydric soils may have small areas of minor nonhydric components in the higher positions on the landform, and map units that are made up dominantly of nonhydric soils may have small areas of minor hydric components in the lower positions on the landform. Each map unit is rated based on its respective components and the percentage of each component within the map unit.

Hydric soils are defined by the National Technical Committee for Hydric Soils (NTCHS) as soils that formed under conditions of saturation, flooding, or ponding long enough during the growing season to develop anaerobic conditions in the upper part (Federal Register, 1994). Under natural conditions, these soils are either saturated or inundated long enough during the growing season to support the growth and reproduction of hydrophytic vegetation.

The NTCHS definition identifies general soil properties that are associated with wetness. In order to determine whether a specific soil is a hydric soil or nonhydric soil, however, more specific information, such as information about the depth and duration of the water table, is needed. Thus, criteria that identify those estimated soil properties unique to hydric soils have been established (Federal Register, 2002). These criteria are used to identify map unit components that normally are associated with wetlands. The criteria used are selected estimated soil properties that are described in "Soil Taxonomy" (Soil Survey Staff, 1999) and "Keys to Soil Taxonomy" (Soil Survey Staff, 2006) and in the "Soil Survey Manual" (Soil Survey Division Staff, 1993). If soils are wet enough for a long enough period of time to be considered hydric, they should exhibit certain properties that can be easily observed in the field. These visible properties are indicators of hydric soils. The indicators used to make onsite determinations of hydric soils are specified in "Field Indicators of Hydric Soils in the United States" (Hurt and Vasilas, 2006).

### *Aerial Photograph*

WSI reviewed aerial photographs to identify suspected wetland areas on the site and to determine changes in wetland areas over time. Our review of the aerial photographs did not suggest any wetland resources within the subject property (Exhibit C).

### *National Wetland Inventory Map*

The US Fish and Wildlife Service (FWS) is the principal US Federal agency tasked with providing information to the public on the status and trends of our Nation's wetlands. The US FWS National Wetlands Inventory (NWI) is a publicly available resource that provides detailed information on the abundance, characteristics, and distribution of US wetlands. Prior to our field inspection of the property, Wetland Sciences, Inc. researched the U.S. Fish and Wildlife Service's National Wetland Inventory Data (Exhibit D). The NWI map suggests the property is comprised entirely of uplands.

### **Field Review**

The desktop review was followed by a pedestrian survey. I personally inspected the property on October 14, 2020. I used technical criteria, field indicators, historic aerial photographs, and other sources of information to assess the site. The evaluation methods followed the routine on-site determination method referenced in the 1987 USACE Manual and 2010 Atlantic and Gulf Coast Regional Supplement.

Wetlands generally have three essential characteristics: hydrophytic vegetation, hydric soils, and wetland hydrology. The techniques for evaluating the plant community, soils, and hydrology are described in the following sections.

### *Hydric Soils Assessment*

Several soil test holes were evaluated in an attempt to identify field indications of hydric soils. WSI utilized the hydric soil definition provided by the National Technical Committee for Hydric Soils and criteria to determine whether soils within the site are considered hydric. It was determined during the desktop review that the soils within the subject property had a hydric rating of less than 0%. A specific area is not necessarily considered to have hydric soils because it is dominated by soils on a hydric soils list. Hydric soils must be identified by verifying the presence of one or more of the hydric soil indicators. During our field inspection of the property, we did not identify any hydric soil indicators within the subject property.

### *Wetland Hydrology Assessment*

Visual indicators of wetland hydrology were evaluated. Examples of primary wetland hydrology indicators include, but are not limited to, surface water, high water table, soil saturation, water marks, sediment deposits, drift deposits, iron deposits, inundation visible on aerial imagery, sparsely vegetated concave surface, and water-stained leaves. If at least one primary or two secondary indicators are observed, the data point location was considered to have wetland hydrology. No wetland hydrologic indicators were noted within the subject property.

### *Field Identification of Wetlands*

During the site inspection, Wetland Sciences, Inc. did not identify any wetlands within the subject property that would fall within the regulatory jurisdiction of the US Army Corps of Engineers (Corps) under 33 CFR 320-330 or the Alabama Department of Environmental Management. It is our opinion, that the entire parcel is comprised of uplands.

Finally, I have included a statement of our firm for services rendered and expenses incurred associated with this effort. If you find this statement in order, please place it in line for payment. If you have any questions, please do not hesitate to contact me at (850) 453-4700.

Respectfully,  
**WETLAND SCIENCES, INC.**

A handwritten signature in black ink, appearing to read "Craig D. Martin". The signature is fluid and cursive, with a long horizontal stroke at the end.

Craig D. Martin M.S.  
Sr. Scientist



Area Subject to wetland delineation  
±16.75 AC



Upland Conveyance Identified by WSI

Approximate Parcel Boundary per Baldwin County GIS Data

Volanta Avenue

Greeno Road North

Upland Conveyance Identified by Wetland Sciences, Inc. October 2020

Culvert

NOTE: This is not a survey. All data within this map are supplied as is, without warranty. This product has not been prepared for legal, engineering, or survey purposes. Users of this information should review or consult the primary data sources to ascertain the usability of the information.

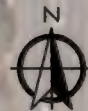

SCALE: 1" = 200 Feet

**WETLAND SCIENCES**  
INCORPORATED

ENVIRONMENTAL CONSULTANTS

3308 GULF BEACH HIGHWAY  
PENSACOLA, FLORIDA 32507  
TEL: 850.453.4700  
CRAIG@WETLANDSCIENCES.COM

PROJECT NAME: Volanta Avenue & Greeno Road

WETLAND SKETCH

PROJECT NO.: 2020-763

DRAWN BY: AJN

DATE: 10/20/2020

SHEET: 1 OF 1

- Appendix F 11 x 17:
1. Boundary and Topographic Survey
  2. Vicinity Map & Underlying Zoning
  3. Comparative Zoning Tables
  4. Conceptual Site Plan
  5. Conceptual Greenspace Plan
  6. Architectural Composite Floor Plan
  7. Architectural Building Elevation
  8. Architectural Rendered Building Elevation
  9. Photometric Plan & Lighting Specification
  10. Tree Preservation and Removal Plan
  11. Landscape Plan

DATE	11/13/20
BY	JADE CONSULTING
PROJECT	GRENO ROAD & VOLANTA AVENUE
CLIENT	FARHOPE, ALABAMA

THIS PLAN IS A PRELIMINARY PLAN AND IS NOT TO BE USED FOR CONSTRUCTION. IT IS THE PROPERTY OF JADE CONSULTING AND IS NOT TO BE REPRODUCED OR TRANSMITTED IN ANY FORM OR BY ANY MEANS, ELECTRONIC OR MECHANICAL, INCLUDING PHOTOCOPYING, RECORDING, OR BY ANY INFORMATION STORAGE AND RETRIEVAL SYSTEM, WITHOUT THE WRITTEN PERMISSION OF JADE CONSULTING.

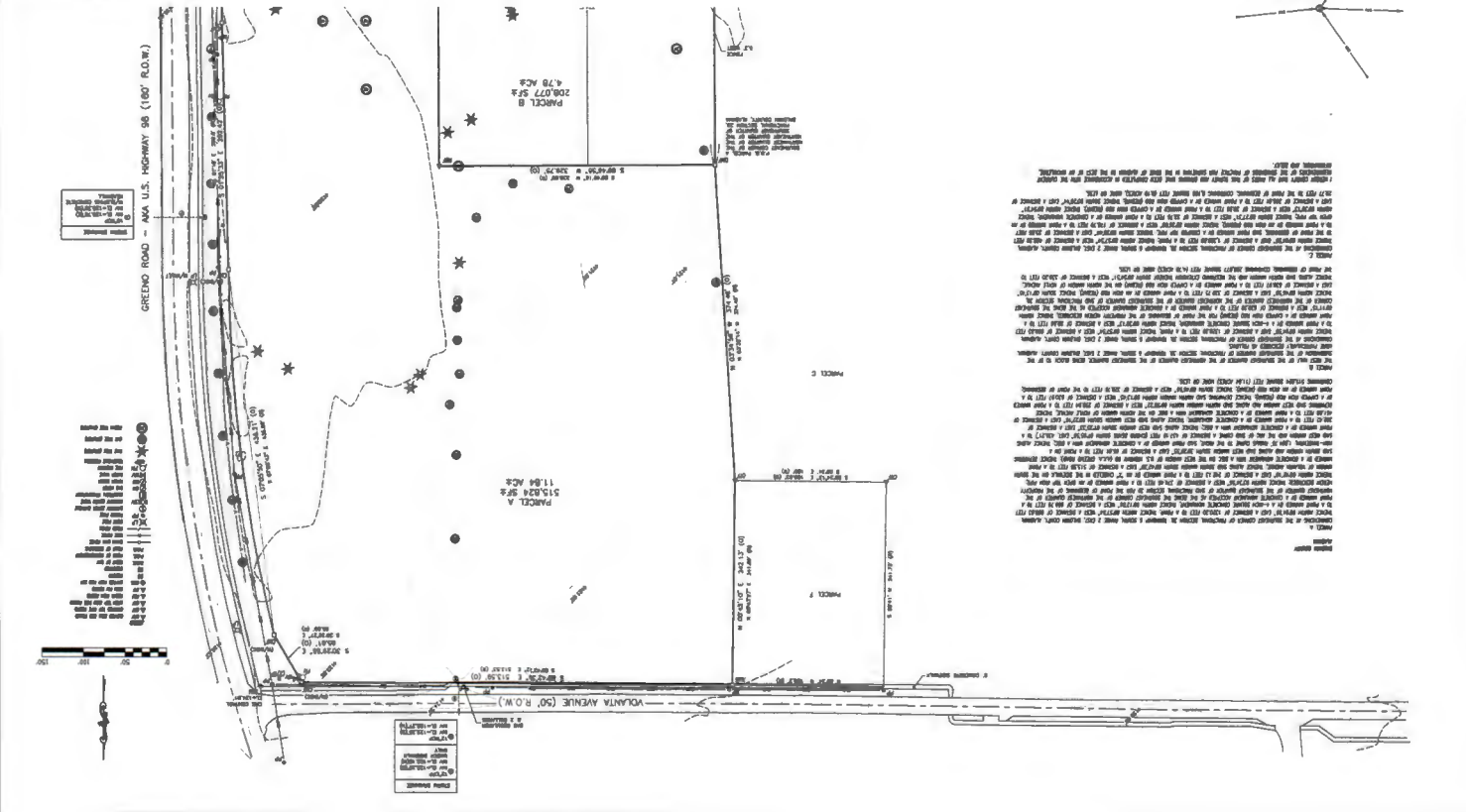

- 1. 180' R.O.W. GRENO ROAD
- 2. 50' R.O.W. VOLANTA AVENUE
- 3. 10' EASEMENT
- 4. 5' EASEMENT
- 5. 10' EASEMENT
- 6. 5' EASEMENT
- 7. 10' EASEMENT
- 8. 5' EASEMENT
- 9. 10' EASEMENT
- 10. 5' EASEMENT
- 11. 10' EASEMENT
- 12. 5' EASEMENT
- 13. 10' EASEMENT
- 14. 5' EASEMENT
- 15. 10' EASEMENT
- 16. 5' EASEMENT
- 17. 10' EASEMENT
- 18. 5' EASEMENT
- 19. 10' EASEMENT
- 20. 5' EASEMENT

THESE ARE THE ORIGINAL RECORDS OF THE PROJECT AND ARE NOT TO BE USED FOR CONSTRUCTION. IT IS THE PROPERTY OF JADE CONSULTING AND IS NOT TO BE REPRODUCED OR TRANSMITTED IN ANY FORM OR BY ANY MEANS, ELECTRONIC OR MECHANICAL, INCLUDING PHOTOCOPYING, RECORDING, OR BY ANY INFORMATION STORAGE AND RETRIEVAL SYSTEM, WITHOUT THE WRITTEN PERMISSION OF JADE CONSULTING.





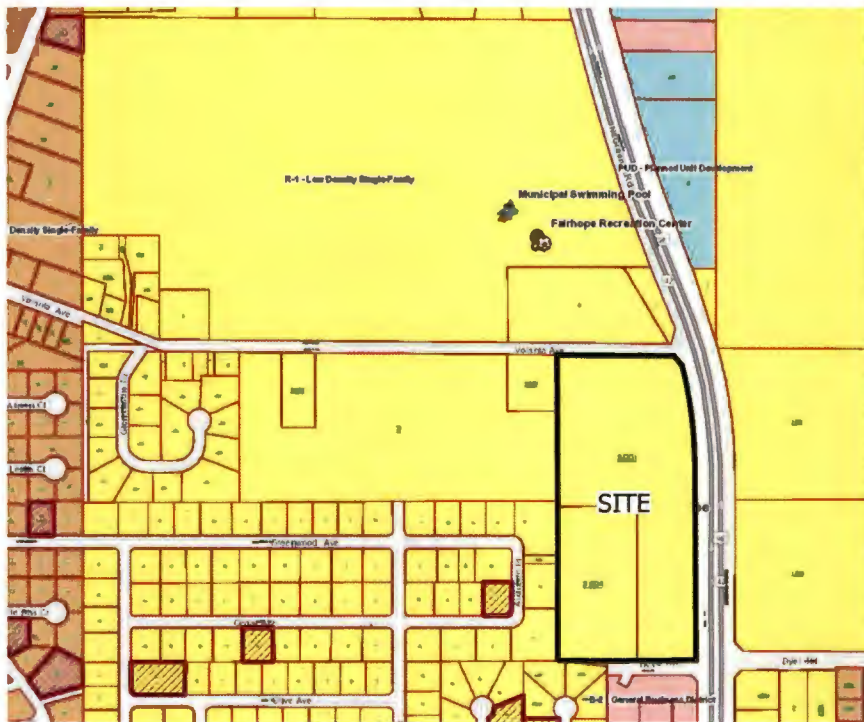

**Legend**

- Pool
- Post Office
- Public Works
- Recreation Center
- School
- Senior Center
- Tennis Center
- Artfield

Control Business District

- Control Business District

Zoning

- S-1 - Local Shopping District
- S-2 - General Business District
- S-3a - Tourist Resort Lodging District
- S-3b - Tourist Resort Commercial Service District
- S-4 - Business and Professional District
- M-1 - Light Industrial District
- P-1 - Parking
- PUD - Planned Unit Development
- R-1 - Low Density Single-Family
- RT(a) - Residential Unclassified
- RT(b) - Residential Unclassified
- RT(c) - Residential Unclassified
- R-2 - Medium Density Single-Family
- R-3 - High Density Single-Family
- R-3PGH - Patio/Garden Single-Family
- R-3TH - Townhouse Single-Family
- R-4 - Low Density Multi-Family
- R-5 - High Density Dwelling Residential
- R-6 - Mobile Home Park District
- RA - Residential/Agriculture District
- TR - Tourist Resort

\*IMAGERY FROM CITY OF FAIRHOPE GIS MAP VIEWER. (POWERED BY KEET CONSULTING SERVICES, LLC)

**VICINITY MAP & UNDERLYING ZONING**  
THE RESERVE AT FAIRHOPE  
PLANNED UNIT DEVELOPMENT  
GREENO ROAD & VOLANTA AVE  
FAIRHOPE, AL

ZONING DIMENSIONS TABLE					
LOT/STRUCTURE REQUIREMENTS	R-1 REQUIREMENTS	R-4 REQUIREMENTS	R-5 REQUIREMENTS	PUD REQUIREMENTS	PROPOSED PUD
MIN. LOT AREA/ALLOWED UPA	15,000 S.F.	10,500 S.F. FOR TWO DWELLING UNITS + 6,500 S.F. FOR EA. ADDITIONAL UNIT / 7 UPA	10,500 S.F. FOR TWO DWELLING UNITS + 4,100 S.F. FOR EA. ADDITIONAL UNIT / 10 UPA	3 AC	16.62 AC / 12.6 UPA
MIN. LOT WIDTH	100'	75' FOR TWO DWELLING UNITS + 5' FOR EA. ADDITIONAL UNIT	75' FOR TWO DWELLING UNITS + 5' FOR EA. ADDITIONAL UNIT	-	513.59'
MIN. FRONT SETBACK	40'	30'	30'	-	30'
MIN. REAR SETBACK	35'	35'	35'	-	30'
MIN. SIDE SETBACK	10'	10'	10'	-	30'
MIN. STREET SIDE SETBACK	20'	20'	20'	-	30'
MAX. TOTAL LOT COVERAGE BY ALL STRUCTURES	40%	30%	30%	-	25%
MAX. BUILDING HEIGHT	30'	30'	30'	-	MAX. 34' EAVE HEIGHT

SITE DATA TABLE	
STATE OF ALABAMA COUNTY OF BALDWIN CITY OF FAIRHOPE	
TAX PARCEL ID:	05-46-03-39-0-002.003.001 05-46-03-39-0-002.003.004
PARCEL SIZE:	16.62 AC
EXISTING ZONING:	R-1, LOW DENSITY SINGLE-FAMILY
PROPOSED ZONING:	PUD
PUD ACREAGE:	16.62 AC
<b>BUILDING SETBACKS:</b>	
FRONT:	30'
SIDE & STREET SIDE:	30'
REAR:	30'
<b>BUILDING AREA &amp; DIMENSIONAL REQUIREMENTS:</b>	
BUILDING HEIGHT:	MAX. 34' EAVE HEIGHT
BUILDING COVERAGE:	MAX. 20% (3.32 AC)
IMPERV. COVERAGE (INC. BLDGS):	MAX. 45% (7.48 AC)
SENIOR HOUSING:	148 TOTAL UNITS      74,748 SF / STORY
	3 STORY - INDEPENDENT LIVING: 84 UNITS (56% OF TOTAL)
	3 STORY - ASSISTED LIVING: 32 UNITS (22% OF TOTAL)
	1 STORY - MEMORY CARE: 32 UNITS (22% OF TOTAL)
DUPLEX VILLAS:	20 UNITS      1,350 SF / UNIT (EXCLUDES GARAGE)
NET DENSITY:	168 UNITS / 16.62 AC = 12.6 UNIT/AC
<b>PARKING STANDARDS:</b>	
	REQUIRED:      PROVIDED:
SENIOR HOUSING VEHICLE PARKING:	1 SPACE / 4 BEDS, PLUS 1 SPACE / 4 EMPLOYEES 148 BEDS + 40 EMPLOYEES = 47 SPACES      178 SPACES (INC. 20 H/C) (INC. 14 COMPACT SPCS)
VILLAS VEHICLE PARKING:	1 SPACE / UNIT 20 UNITS = 20 SPACES      30 SPACES (INC. 4 H/C)
<b>SIDEWALK &amp; STREET REQUIREMENTS:</b>	
SIDEWALK WIDTH:	MIN. 5' WIDTH
PARKING SPACES:	10'x20'
COMPACT PARKING SPACES:	8'x15'
DRIVE AISLE (SENIOR HOUSING):	26' WIDE
DRIVE AISLE (DUPLEX):	24' WIDE

PROVIDED PARKING BREAKDOWN TABLE	
	PARKING PROVIDED
SENIOR HOUSING INDEPENDENT LIVING	84 SPACES
SENIOR HOUSING ASSISTED LIVING, MEMORY CARE, & STAFF	33 SPACES
COMPACT PARKING SPACES	14 SPACES
PERVIOUS PARKING SPACES	47 SPACES
TOTAL PARKING SPACES	178 SPACES

**COMPARATIVE ZONING TABLE**  
 THE RESERVE AT FAIRHOPE  
 PLANNED UNIT DEVELOPMENT  
 GREENO ROAD & VOLANTA AVE  
 FAIRHOPE, AL



JINRIGHT & ASSOCIATES DEVELOPMENT ENGINEERS  
 208 Greeno Road N., Ste. C Fairhope, Alabama 36532  
 P.O. Box 1929 Fairhope, Alabama 36533  
 Phone: (251) 928-8663 Fax: (251) 928-8665  
 jade@jadecon.com

DATE: 11/13/2020

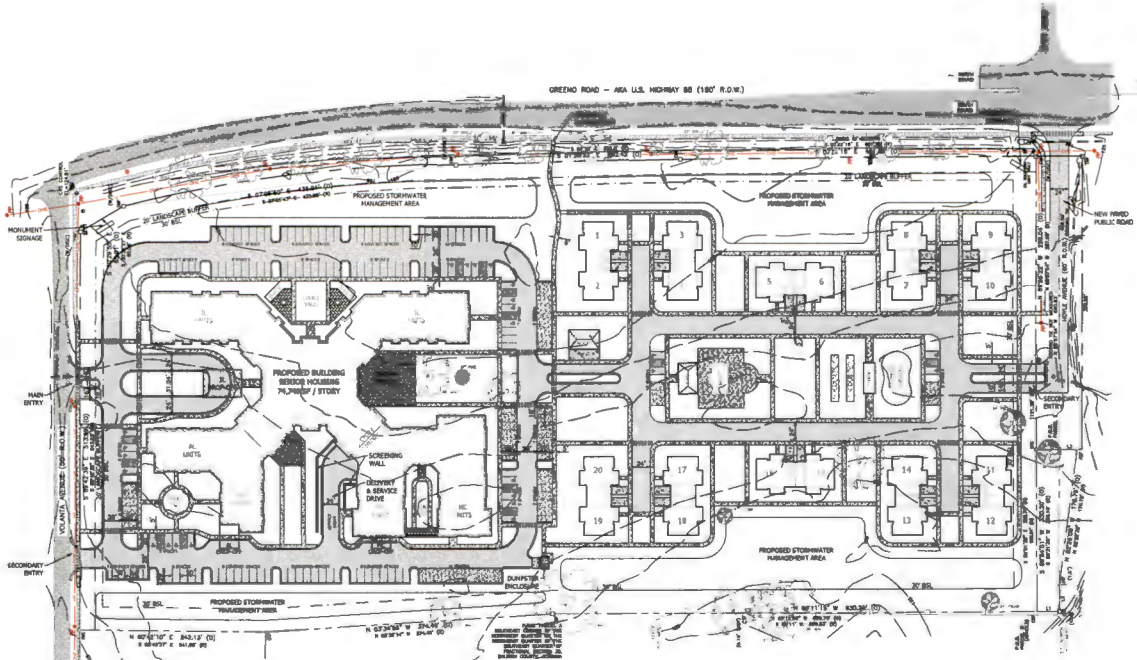

SITE DATA TABLE	
TAX PARCEL ID	05-00-07-20-000-003.001 05-00-07-20-000-003.002
PARCEL SIZE	18.62 AC
EXISTING ZONING	R-1.5 LOW DENSITY SINGLE-FAMILY
PROPOSED ZONING	PUD
PUD ACORAGE	18.62 AC
FRONT	30'
SIDE & STREET SIDE	30'
REAR	30'
BUILDING HEIGHT	MAX. 30' 6" MAX HEIGHT
BUILDING COVERAGE	MAX. 20% (3.72 AC)
IMPERV. COVERAGE (INC. BLDGS)	MAX. 40% (7.46 AC)
SENIOR HOUSING	248 TOTAL UNITS   74 UNITS @ 1 STORY 3 STORY - ASSISTED LIVING: 33 UNITS (24% OF TOTAL) 1 STORY - ASSISTED LIVING: 32 UNITS (24% OF TOTAL)
DUPLEX VILLAGE	30 UNITS   1,200 SF / UNIT (EXCLUDES GARAGE)
NET DENSITY	300 UNITS / 18.62 AC = 16.12 UNITS/AC
SENIOR HOUSING VEHICLE PARKING	1.4 SF = 4.86E. PER 1 UNIT OF VEHICLES 1.0 SF = 3.24E. PER 1 UNIT OF VEHICLES 1.0 SF = 3.24E. PER 1 UNIT OF VEHICLES
VILLAGE VEHICLE PARKING	1.5 SF PER UNIT 1.5 SF PER UNIT 30 SPACES (INC. 4 PWS)
SIDEWALK WIDTH	MIN. 5' WIDTH
PARKING SPACES	30/25
COMPACT PARKING SPACES	0/25
DRIVE ALLEYS (SENIOR HOUSING)	30' WIDE
DRIVE ALLEYS (VILLAGE)	34' WIDE

**SIGN NOTES:**  
 PROPOSED MONUMENT SIGNS SHALL MEET THE CITY OF FAIRHOPE SIGN ORDINANCE.

**LEGEND**

- PROPOSED ASPHALT PAVEMENT
- PROPOSED HEAVY DUTY CONCRETE (BROOM FINISH)
- PROPOSED PERMEABLE PAVEMENT
- PROPOSED DECORATIVE CONCRETE
- PROPOSED LIGHT DUTY CONCRETE (BROOM FINISH)

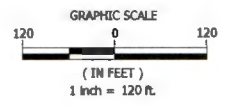

CONCEPTUAL SITE PLAN  
 THE RESERVE AT FAIRHOPE  
 PLANNED UNIT DEVELOPMENT  
 GREENO ROAD & VOLANTA AVE  
 FAIRHOPE, AL



JINRIGHT & ASSOCIATES DEVELOPMENT ENGINEERS  
 206 Green Road N., Ste. C Fairhope, Alabama 36532  
 P.O. Box 1929 Fairhope, Alabama 36533  
 Phone: (251) 928-3443 Fax: (251) 928-3665  
 jadam@jrc.com

DATE: 11/13/2020

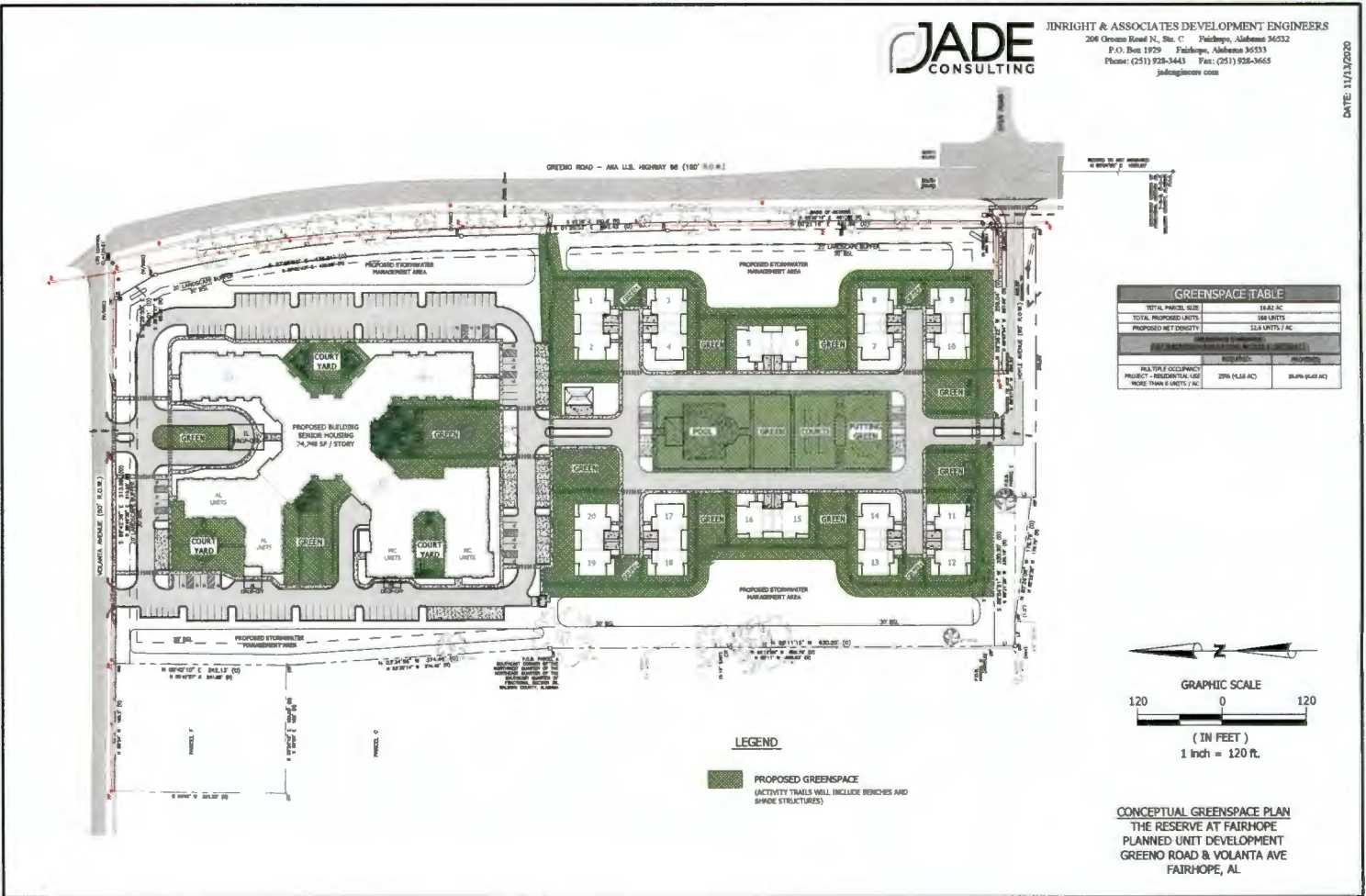

GREENSPACE TABLE	
TOTAL PARCEL SIZE	1642 AC
TOTAL PROPOSED UNITS	188 UNITS
PROPOSED NET DENSITY	124 UNITS / AC
100% GREENSPACE REQUIREMENT (100% OF UNITS)	
PROPOSED GREENSPACE	2796 (1.68 AC)
MINIMUM OCCUPANCY REQUIREMENT (RESIDENTIAL USE MORE THAN 4 UNITS / AC)	28,000 (16.8 AC)

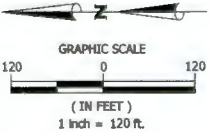

**LEGEND**

PROPOSED GREENSPACE  
 (ACTIVITY TRAILS WILL INCLUDE BENCHES AND SHADE STRUCTURES)

**CONCEPTUAL GREENSPACE PLAN**  
 THE RESERVE AT FAIRHOPE  
 PLANNED UNIT DEVELOPMENT  
 GREENO ROAD & VOLANTA AVE  
 FAIRHOPE, AL

# Composite Floor Plan - Level 1

Volanta Ave & Greeno Rd - Fairhope, AL

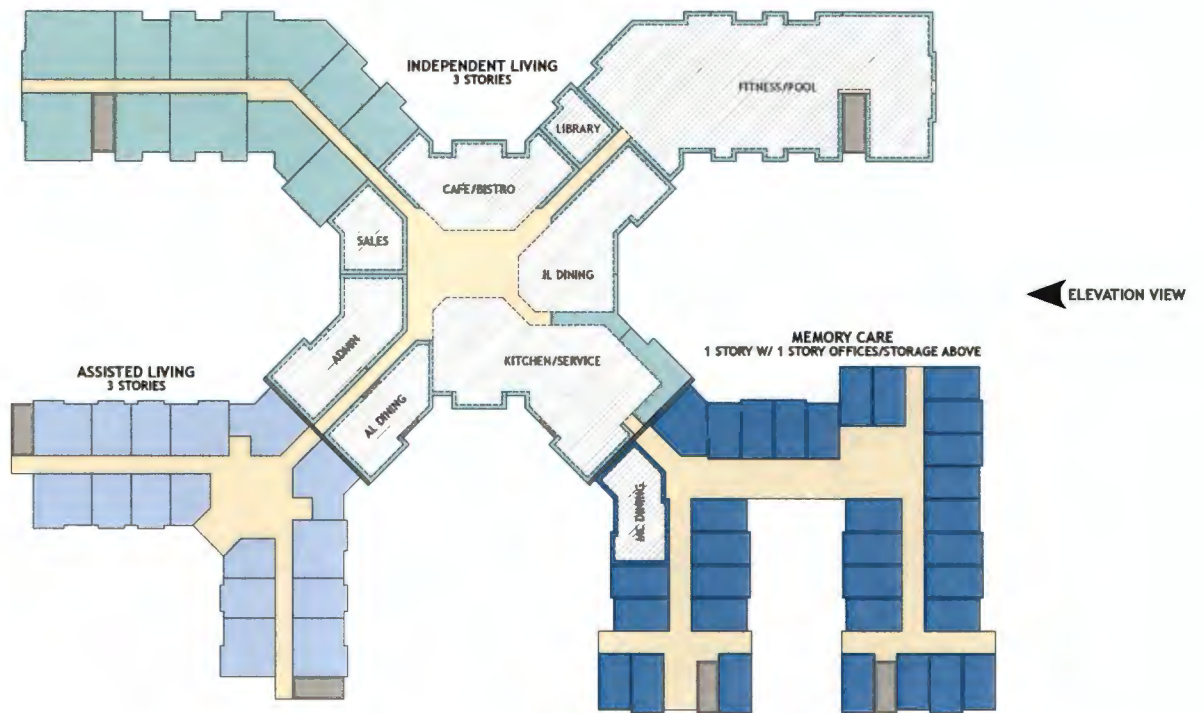

**Elevation View**  
Volanta Ave & Greeno Rd - Fairhope, AL

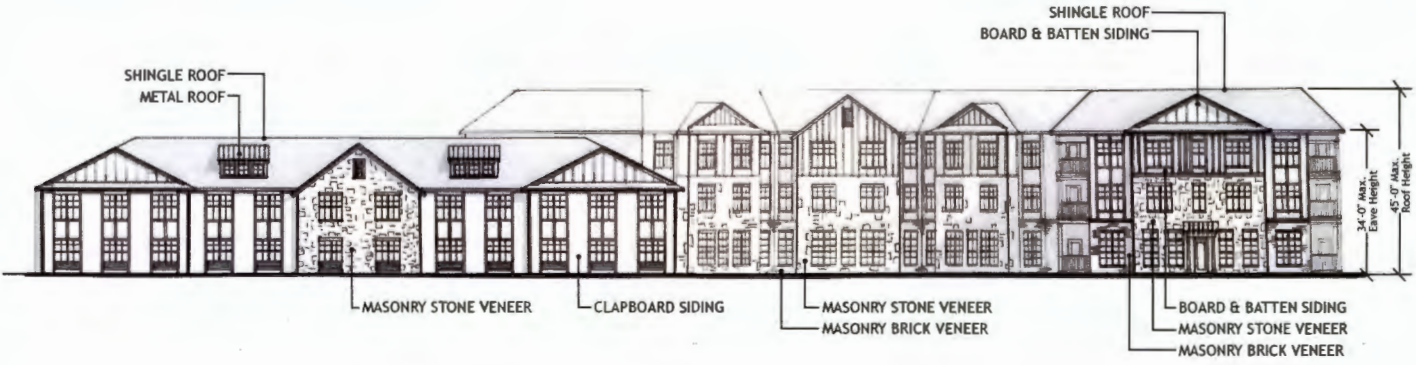

# Rendered Elevation View

Volanta Ave & Greeno Rd - Fairhope, AL









# Dominion Partners; Fairhope, Alabama 1.6



800 Battery Avenue SE  
Suite 410  
Atlanta, GA 30339

**Dominion Partners - Fairhope, Alabama**  
Photometrics 1.6  
(120 Watt Fixture)  
10/12/2020

## Luminaire Summary

Luminaire Schedule						
Symbol	Qty	Label	Arrangement	Total Lamp Lumens	LLF	Description
	40	A	SINGLE	N.A.	0.900	CY55P1B-FGC-3HS-120W-3K
	1	A2	BACK-BACK	N.A.	0.900	CY55P1B-FGC-3HS-120W-3K
	12	B	SINGLE	N.A.	0.900	CY55P1B-FGC-4HS-120W-3K



800 Battery Avenue SE  
Suite 410  
Atlanta, GA 30339

**Dominion Partners - Fairhope, Alabama**  
Photometrics 1.6  
(120 Watt Fixture)  
10/12/2020

## Luminaire Images



A

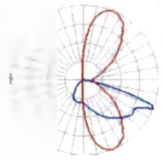

A2

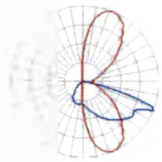

B

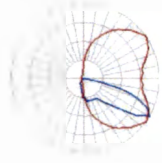

800 Battery Avenue SE  
Suite 410  
Atlanta, GA 30339

**Dominion Partners - Fairhope, Alabama**  
Photometrics 1.6  
(120 Watt Fixture)  
10/12/2020

## Calculation Summary

Calculation Summary							
Label	CalcType	Units	Avg	Max	Min	Avg/Min	Max/Min
Parking (5 Spaces)	Illuminance	Fc	1.91	3.7	0.8	2.39	4.63
Parking (Center)	Illuminance	Fc	3.08	5.4	0.6	5.13	9.00
Parking (East)	Illuminance	Fc	2.84	5.5	0.8	3.55	6.88
Parking (New)	Illuminance	Fc	3.39	5.2	1.0	3.39	5.20
Parking (South)	Illuminance	Fc	3.36	5.4	1.2	2.80	4.50
Parking (West)	Illuminance	Fc	2.82	5.2	0.7	4.03	7.43
Perimeter (New)	Illuminance	Fc	0.00	0.0	0.0	N.A.	N.A.
Roadway (New)	Illuminance	Fc	2.10	6.2	0.2	10.50	31.00



800 Battery Avenue SE  
Suite 410  
Atlanta, GA 30339

**Dominion Partners - Fairhope, Alabama**  
Photometrics 1.6  
(120 Watt Fixture)  
10/12/2020

# Viewpoint

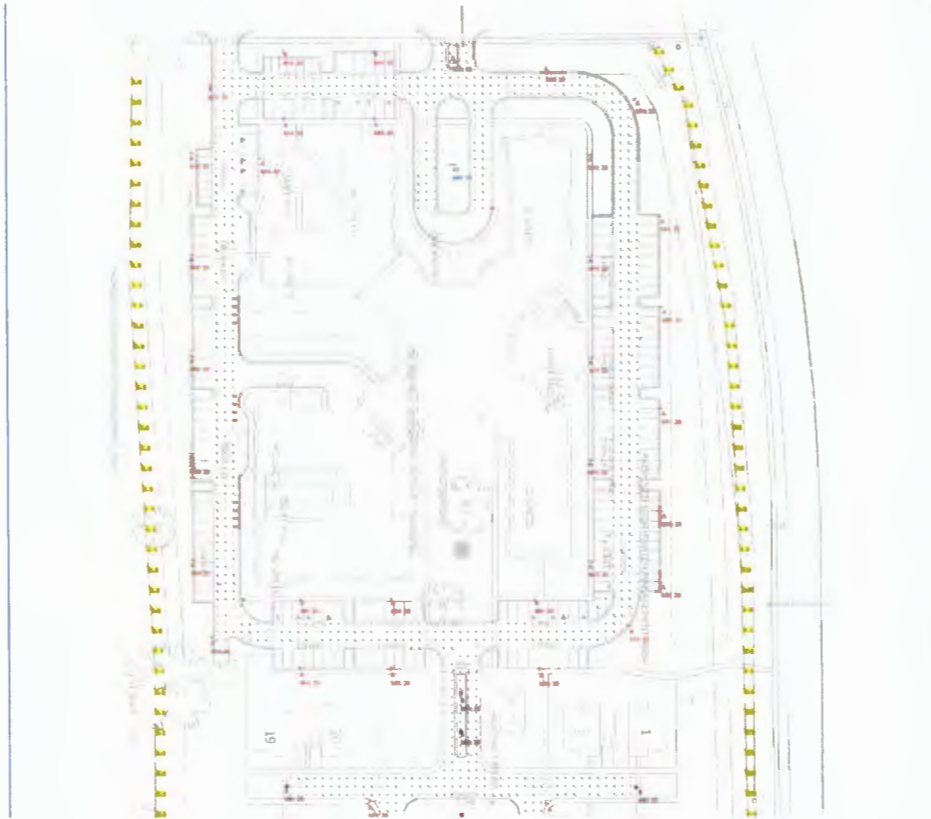

VIEWPOINT: Viewpoint\_3



800 Battery Avenue SE  
Suite 410  
Atlanta, GA 30339

**Dominion Partners - Fairhope, Alabama**  
Photometrics 1.6  
(120 Watt Fixture)  
10/12/2020

**Viewpoint - Cont.**

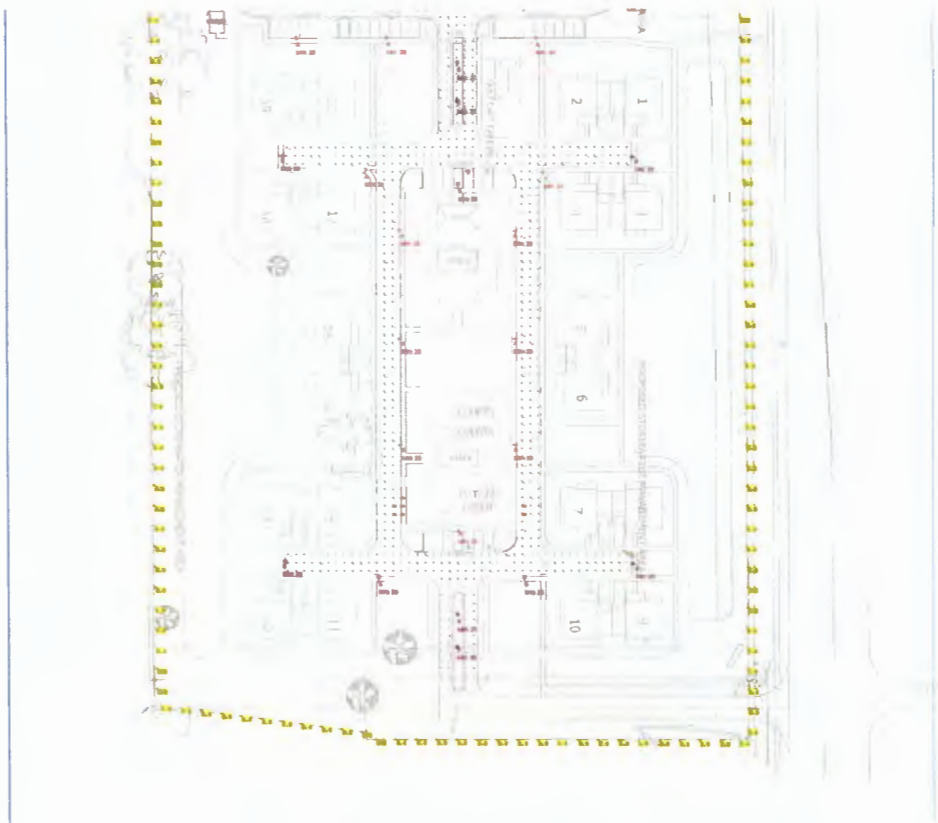

VIEWPOINT: Viewpoint\_4



800 Battery Avenue SE  
Suite 410  
Atlanta, GA 30339

**Dominion Partners - Fairhope, Alabama**  
Photometrics 1.6  
(120 Watt Fixture)  
10/12/2020

**Render View**

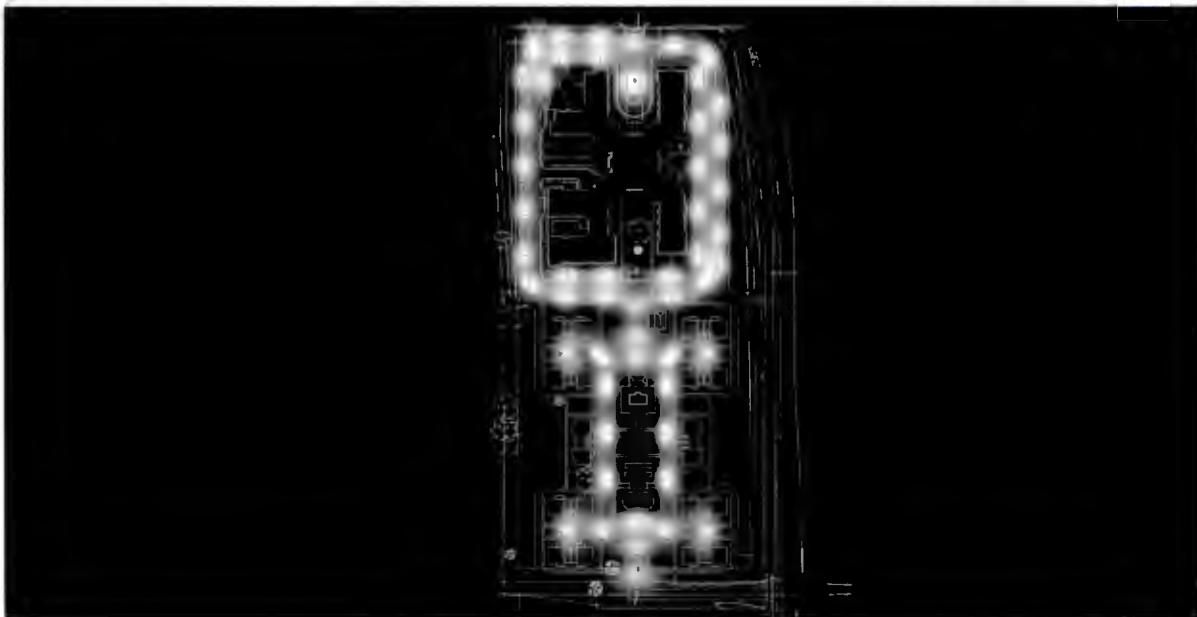

RenderViewpoint\_3



800 Battery Avenue SE  
Suite 410  
Atlanta, GA 30339

**Dominion Partners - Fairhope, Alabama**  
Photometrics 1.6  
(120 Watt Fixture)  
10/12/2020

## Render View - Cont.

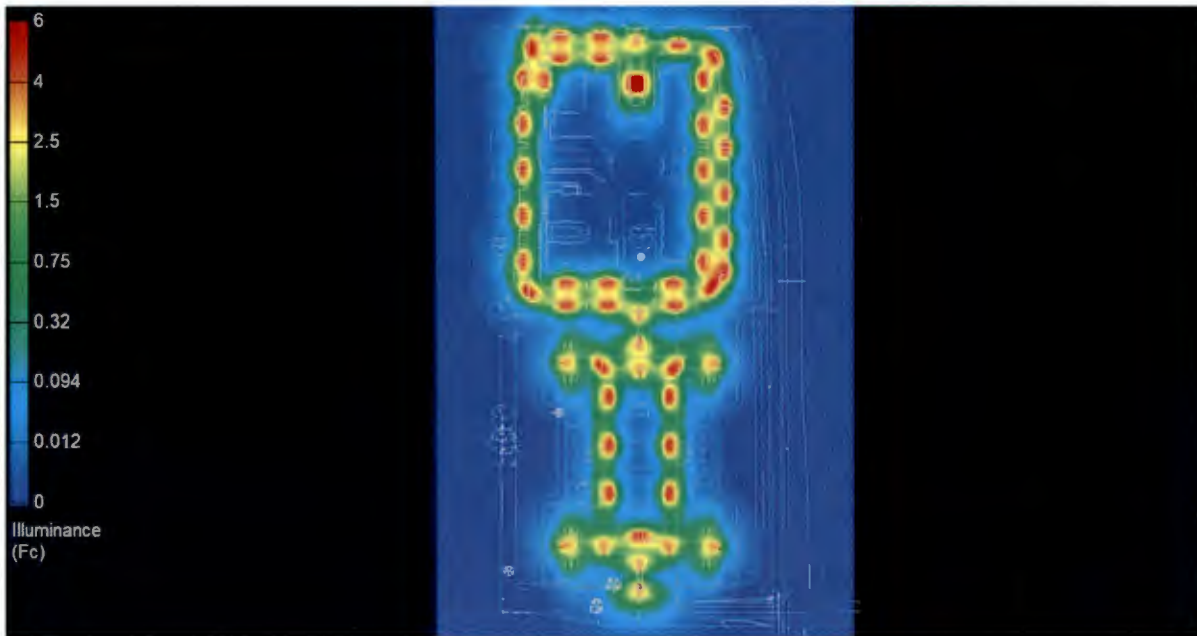

RenderViewpoint\_4



800 Battery Avenue SE  
Suite 410  
Atlanta, GA 30339

**Dominion Partners - Fairhope, Alabama**  
Photometrics 1.6  
(120 Watt Fixture)  
10/12/2020



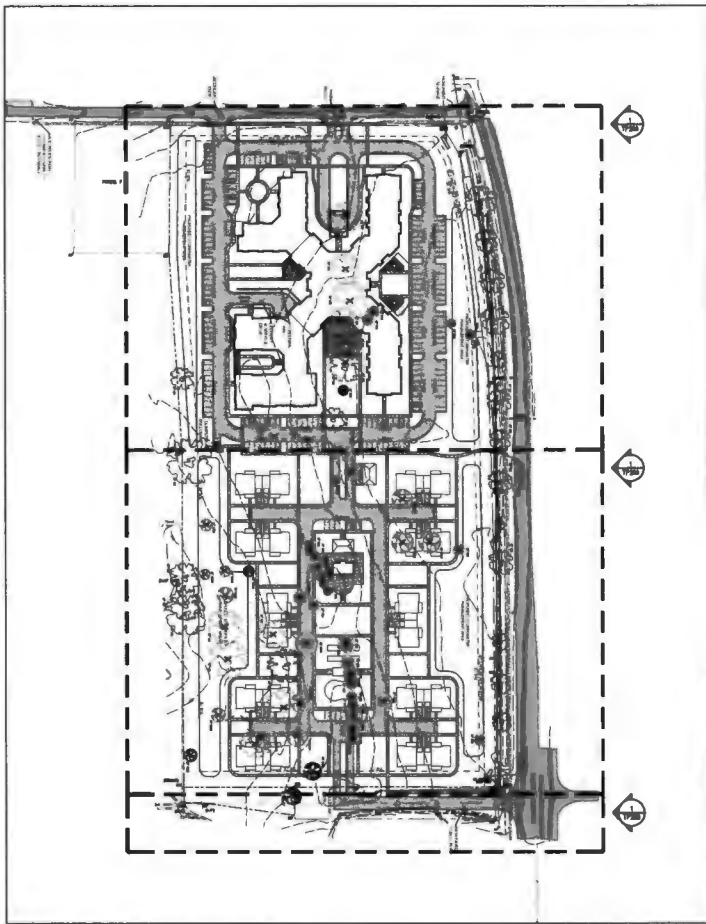

Tree ID	Species	DBH (in)	Height (ft)	Health	Preservation Status
1	...	...	...	...	...
2	...	...	...	...	...
3	...	...	...	...	...
4	...	...	...	...	...
5	...	...	...	...	...
6	...	...	...	...	...
7	...	...	...	...	...
8	...	...	...	...	...
9	...	...	...	...	...
10	...	...	...	...	...
11	...	...	...	...	...
12	...	...	...	...	...
13	...	...	...	...	...
14	...	...	...	...	...
15	...	...	...	...	...
16	...	...	...	...	...
17	...	...	...	...	...
18	...	...	...	...	...
19	...	...	...	...	...
20	...	...	...	...	...
21	...	...	...	...	...
22	...	...	...	...	...
23	...	...	...	...	...
24	...	...	...	...	...
25	...	...	...	...	...
26	...	...	...	...	...
27	...	...	...	...	...
28	...	...	...	...	...
29	...	...	...	...	...
30	...	...	...	...	...
31	...	...	...	...	...
32	...	...	...	...	...
33	...	...	...	...	...
34	...	...	...	...	...
35	...	...	...	...	...
36	...	...	...	...	...
37	...	...	...	...	...
38	...	...	...	...	...
39	...	...	...	...	...
40	...	...	...	...	...
41	...	...	...	...	...
42	...	...	...	...	...
43	...	...	...	...	...
44	...	...	...	...	...
45	...	...	...	...	...
46	...	...	...	...	...
47	...	...	...	...	...
48	...	...	...	...	...
49	...	...	...	...	...
50	...	...	...	...	...

**TREE PRESERVATION NOTES**

1. All trees shown on this plan were field inspected on 10/15/10.
2. All trees shown on this plan were field inspected on 10/15/10.
3. All trees shown on this plan were field inspected on 10/15/10.
4. All trees shown on this plan were field inspected on 10/15/10.
5. All trees shown on this plan were field inspected on 10/15/10.
6. All trees shown on this plan were field inspected on 10/15/10.
7. All trees shown on this plan were field inspected on 10/15/10.
8. All trees shown on this plan were field inspected on 10/15/10.
9. All trees shown on this plan were field inspected on 10/15/10.
10. All trees shown on this plan were field inspected on 10/15/10.

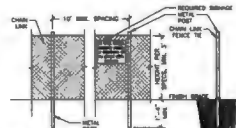

**2) TREE PROTECTION FENCE - C**  
1/2" = 1'-0"

1. Fencing to be installed prior to construction. Fencing type shall be as shown.
2. The fence shall be installed at a min. distance of 30' from the trunk of a tree to be preserved.
3. The fence shall be installed at a min. distance of 30' from the trunk of a tree to be preserved.
4. The fence shall be installed at a min. distance of 30' from the trunk of a tree to be preserved.
5. The fence shall be installed at a min. distance of 30' from the trunk of a tree to be preserved.
6. The fence shall be installed at a min. distance of 30' from the trunk of a tree to be preserved.
7. The fence shall be installed at a min. distance of 30' from the trunk of a tree to be preserved.
8. The fence shall be installed at a min. distance of 30' from the trunk of a tree to be preserved.
9. The fence shall be installed at a min. distance of 30' from the trunk of a tree to be preserved.
10. The fence shall be installed at a min. distance of 30' from the trunk of a tree to be preserved.

1 OVERALL TREE PRESERVATION & REMOVAL PLAN  
Scale: 1/4" = 1'-0"

**was DESIGN**  
landscape architects

**NOT**  
FIELD INSPECTION  
FIELD INSPECTION AND REPORT APPROVAL AND ALL SUBJECT TO CHANGE

A Landscape Development Plan for  
**The Reserve at Fairhope**  
Fairhope, Alabama

No. \_\_\_\_\_ Date \_\_\_\_\_ Reviewer / Submitter \_\_\_\_\_  
 No. \_\_\_\_\_ Date \_\_\_\_\_ Reviewer / Submitter \_\_\_\_\_  
 No. \_\_\_\_\_ Date \_\_\_\_\_ Reviewer / Submitter \_\_\_\_\_  
 No. \_\_\_\_\_ Date \_\_\_\_\_ Reviewer / Submitter \_\_\_\_\_

VIT  
Date \_\_\_\_\_  
 City \_\_\_\_\_  
 State \_\_\_\_\_  
 Zip \_\_\_\_\_

STATE OF ALABAMA  
 PROFESSIONAL SEAL  
 518

**TREE PRESERVATION & REMOVAL MASTER PLAN**

Plan No. **TP100**

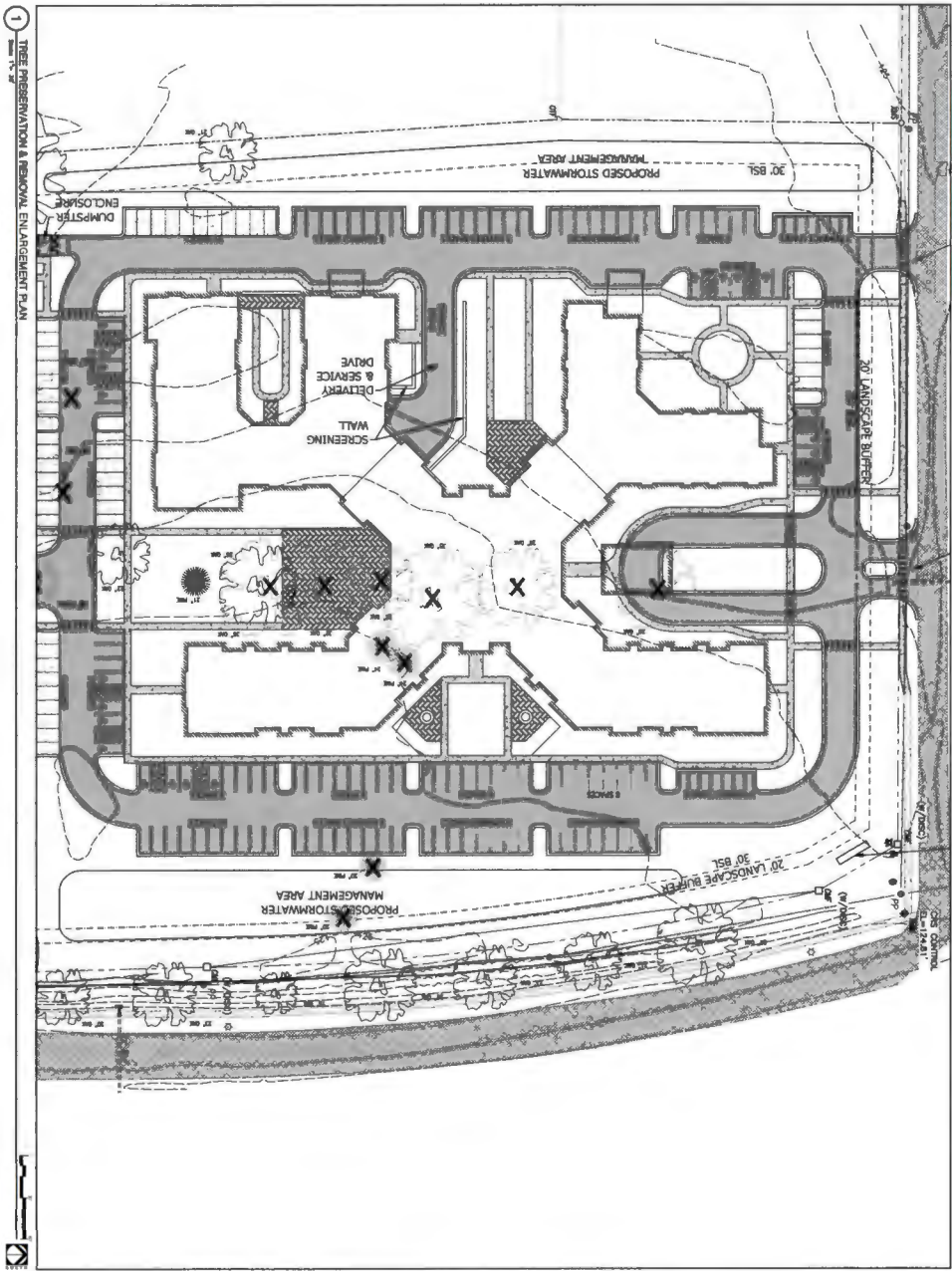

1 TREE PRESERVATION & REMOVAL ENLARGEMENT PLAN



**NOT**  
 SCALE  
 1/8" = 1'-0"

A Landscape Development Plan for  
**The Reserve at Fairhope**  
 Fairhope, Alabama

DATE	10/11/2011
BY	W&S DESIGN
CHECKED BY	W&S DESIGN
SCALE	AS SHOWN
PROJECT NO.	11-001
DATE	10/11/2011



TREE  
 PRESERVATION &  
 REMOVAL PLAN

TP200

1 TREE PRESERVATION & REMOVAL ENGAGEMENT PLAN

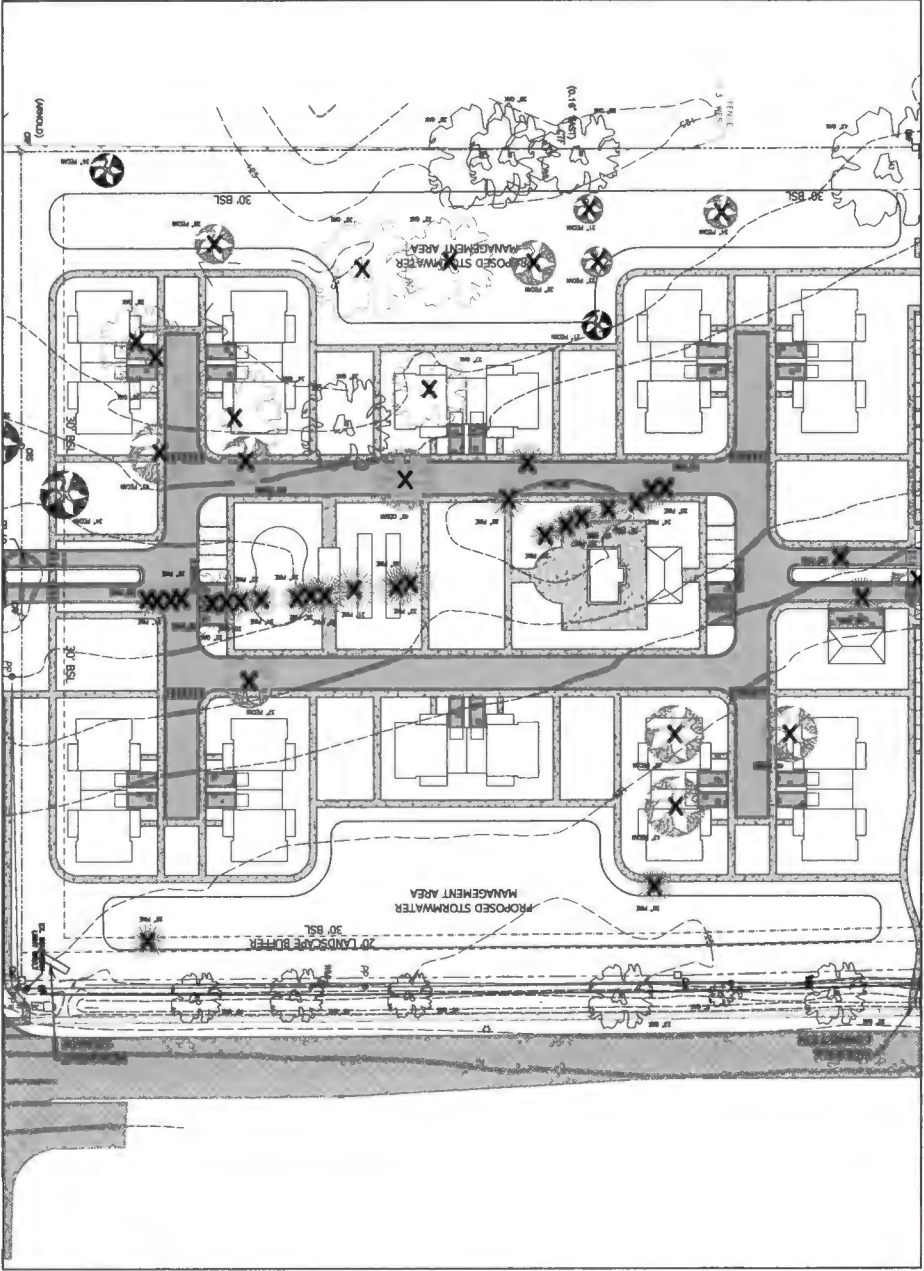

**NOT**  
 TO BE USED FOR CONSTRUCTION  
 WITHOUT THE APPROVAL OF THE  
 ARCHITECT

A Landscape Development Plan for  
**The Reserve at Fairhope**  
 Fairhope, Alabama

DATE	10/15/2010
BY	J. S. [Signature]
CHECKED BY	[Signature]
SCALE	AS SHOWN
PROJECT	THE RESERVE AT FAIRHOPE
LOCATION	FAIRHOPE, ALABAMA
DESIGNED BY	M&S DESIGN
DATE	10/15/2010
PROJECT NO.	10001-200
DATE	10/15/2010

TREE  
 PRESERVATION &  
 REMOVAL PLAN

TP201

**NOT**  
 FOR CONSTRUCTION  
 THESE PLANS ARE NOT FOR  
 APPROVAL AND ARE SUBJECT  
 TO CHANGE

A Landscape Development Plan for  
**The Reserve at Fairhope**  
 Fairhope, Alabama

Rev.	Date	Revised / Submitted
01	08.28.20	CONCEPT
02	09.29.20	CITY SUBMITTAL
03	11.16.20	CITY ST-REVISIONS

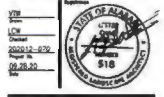

**TREE**  
**PRESERVATION &**  
**REMOVAL PLAN**

**TP202**

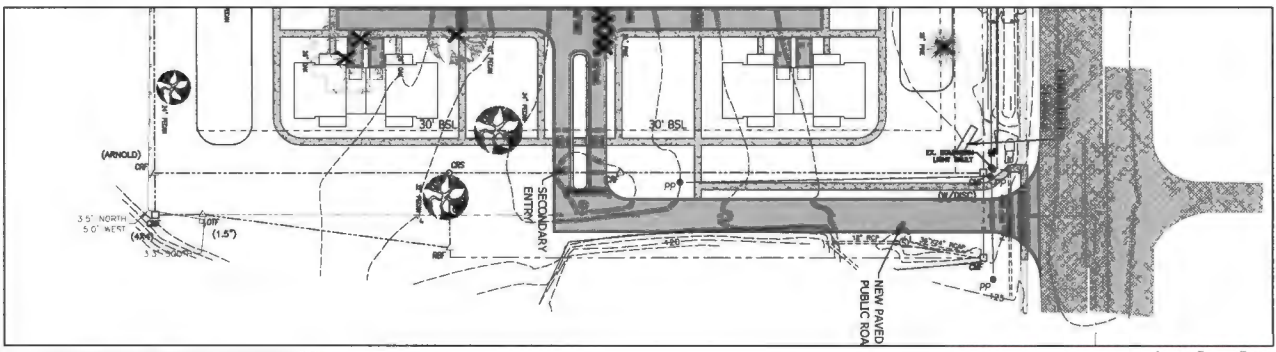

1 TREE PRESERVATION & REMOVAL ENLARGEMENT PLAN  
 Scale: 1" = 30'

### GENERAL NOTES

**COMMON AREA TREATMENT:**  
 ALL COMMON AREA SPACES TO BE LANDSCAPED WITH VARIOUS PLANTING MATERIALS SUCH AS TURF, PLANTINGS, CANOPY TREES AND UNDERSTORY TREES TO PROVIDE A BALANCED LANDSCAPE THROUGHOUT THE DEVELOPMENT.

**DISTURBED AREAS:**  
 ANY DISTURBED AREAS SHALL RECEIVE SOO DR MULCH AS NECESSARY PER MUNICIPALITY REQUIREMENTS. ALL LANDSCAPE BESS ARE TO RECEIVE 3" DEPTH LONG LEAF PINE STRAW SETTLED.

**QUANTITY TAKEOFF DISCREPANCIES:**  
 QUANTITIES NOTED ON PLANS ARE OFFERED AS A CONVENIENCE TO THE CONTRACTOR. CONTRACTOR SHALL VERIFY ALL QUANTITIES AND REPORT ANY DISCREPANCIES TO THE LANDSCAPE ARCHITECT.

**IRRIGATION SYSTEM NOTES:**  
 IRRIGATION PERFORMANCE PLANTING AREAS ARE TO RECEIVE 100% HEAD-TO-HEAD COVERAGE WITH AN EVENLY DISTRIBUTED PRECIPITATION RATES AS POSSIBLE. CARE SHOULD BE TAKEN IN CONSIDERATION OF MATURE PLANT HEIGHT AND PROVISION MADE FOR PLANT GROWTH OVER TIME.

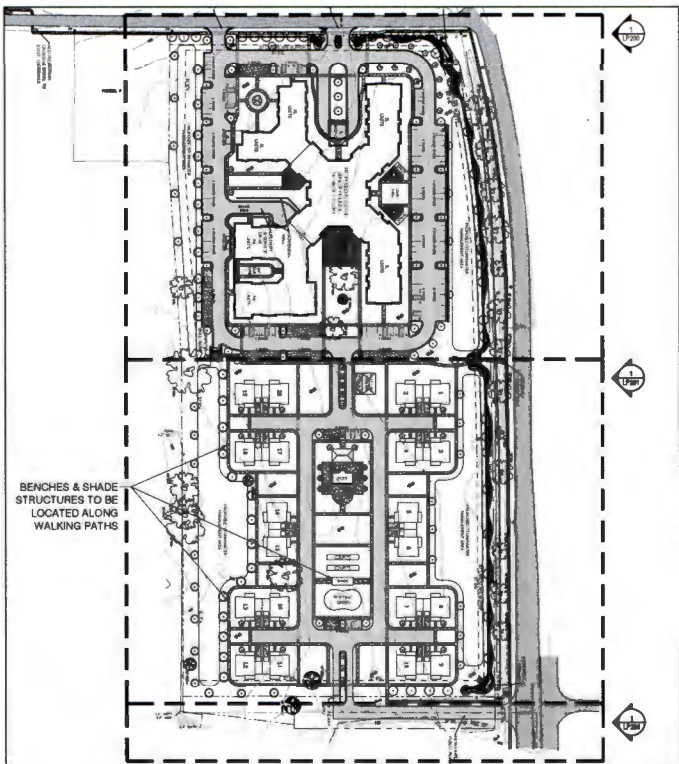

1 LANDSCAPE MASTER PLAN  
 Scale: 1" = 30'

### PLANT SCHEDULE

SYMBOL	CODE	QTY	BOTANICAL NAME	COMMON NAME	CONT.	SHA.	HT.	REMARKS
BT	01	1	Styl. / alternate Tree Planting	Bell Planting Variety	300 gal or Cost	7'Chd	8'	Standard
LA	02	1	Ligustrum lucidum 'Nodosa'	Yucca / Orange Spatha	30 gal	7'Chd	6'-10'	6000 on 2 notes: 800 total
OR	03	1	Stipagrostis pennata 'Clouds Winesap'	Clouds W / Stipagrostis	30 gal	7'Chd	6'-10'	Full to ground
FP	04	1	Platanus alternata	Chinese Platanus	300 gal or Cost	7'Chd	10'	Full to ground, specimen quality
PO	05	1	Platanus occidentalis	American Sycamore	300 gal or Cost	7'Chd	10'	Full to ground, specimen quality
OH	06	1	Cornus hybrid	Hallel Oak	300 gal or Cost	7'Chd	10'	Full to ground, specimen quality
OR	07	1	Cornus nigra	Beethoven Line Oak	300 gal or Cost	7'Chd	10'	Full to ground, specimen quality
TO	08	1	Taxodium distichum	Bell Cypress	300 gal or Cost	7'Chd	10'	Full to ground, specimen quality

SYMBOL	CODE	QTY	BOTANICAL NAME	COMMON NAME	CONT.	HT.	REMARKS
VA	01	1	Abies concolor 'Vanguard'	Vanguard Blue Spruce	3 gal		47" x 3"
CA	02	1	Calluna ssp. 'White Goddess'	White Goddess Calluna	3 gal		30" x 3"
DND	03	1	Drumstick 'Village Jamb'	Village Jamb Drumstick	3 gal		40" x 3"
VP	04	1	Verticillium perfoliatum 'Prospere'	Prospere Verticillium	3 gal		30" x 3"
LD	05	1	Lawsonia tinctoria 'Tussock Gold'	Tussock Gold Holly	3 gal		30" x 3"
PD	06	1	Leucophaea obtusata 'Purple Ribbon'	Purple Ribbon Leucophaea	3 gal		42" x 3"
DB	07	1	Desmodium illinoense	Small Clematis	3 gal		40" x 3"

SYMBOL	CODE	QTY	BOTANICAL NAME	COMMON NAME	CONT.	HT.	REMARKS
JG	01	1	Juncus tenuis 'Prospere'	Prospere Juncus	3 gal		30" x 3"
AD	02	1	Andropogon scoparius	Astoria Scouring Broom	3 gal		30" x 3"

SYMBOL	CODE	QTY	BOTANICAL NAME	COMMON NAME	CONT.	HT.	REMARKS
AG	01	1	Agave attenuata 'Blue'	Blue Lily of the Nile	1 gal		10" x 3"
DR	02	1	Dracaena marginata	White Ribbon Dracaena	1 gal		30" x 3"
LT	03	1	Leucaena leucostachya 'Vanguard'	Vanguard Leucaena	1 gal		10" x 3"
RD	04	1	Red Pine ssp. 'Millenium'	Red Pine ssp.	1 gal		30" x 3"
BC	05	1	Baccharis distachya	Sheep Pen	40 gal		12" x 3"

### LANDSCAPE REQUIREMENTS

<b>Street Planting (Outside) Zone:</b>	
1 tree per 100 LF 100' @ 100 GAL	100 trees
Required Planting Density:	60 trees
Proposed Planting Density:	50 trees
<b>Way Side:</b>	
1 tree per 200 LF 100' @ 100 GAL	40 trees
Required Planting Density:	40 trees
Proposed Planting Density:	40 trees
<b>Non-Planting Zone:</b>	
1 tree per 200 LF 100' @ 100 GAL	40 trees
Required Planting Density:	40 trees
Proposed Planting Density:	40 trees
<b>Other:</b>	
1 tree per 100 LF @ 100 GAL	100 trees
Required Planting:	100 trees
Proposed Planting:	100 trees



**NOT**  
 FOR CONSTRUCTION  
 THIS PLAN HAS NOT BEEN  
 APPROVED AND IS SUBJECT  
 TO CHANGE

A Landscape Development Plan for  
**The Reserve at Fairhope**  
 Fairhope, Alabama

Date	By	Revised / Updated
2000/12-09	WAS	01-15-02
2001/02-20	WAS	01-15-02
2001/03-09	WAS	01-15-02
2001/03-09	WAS	01-15-02



LANDSCAPE  
 MASTER PLAN

Page No. **LP100**

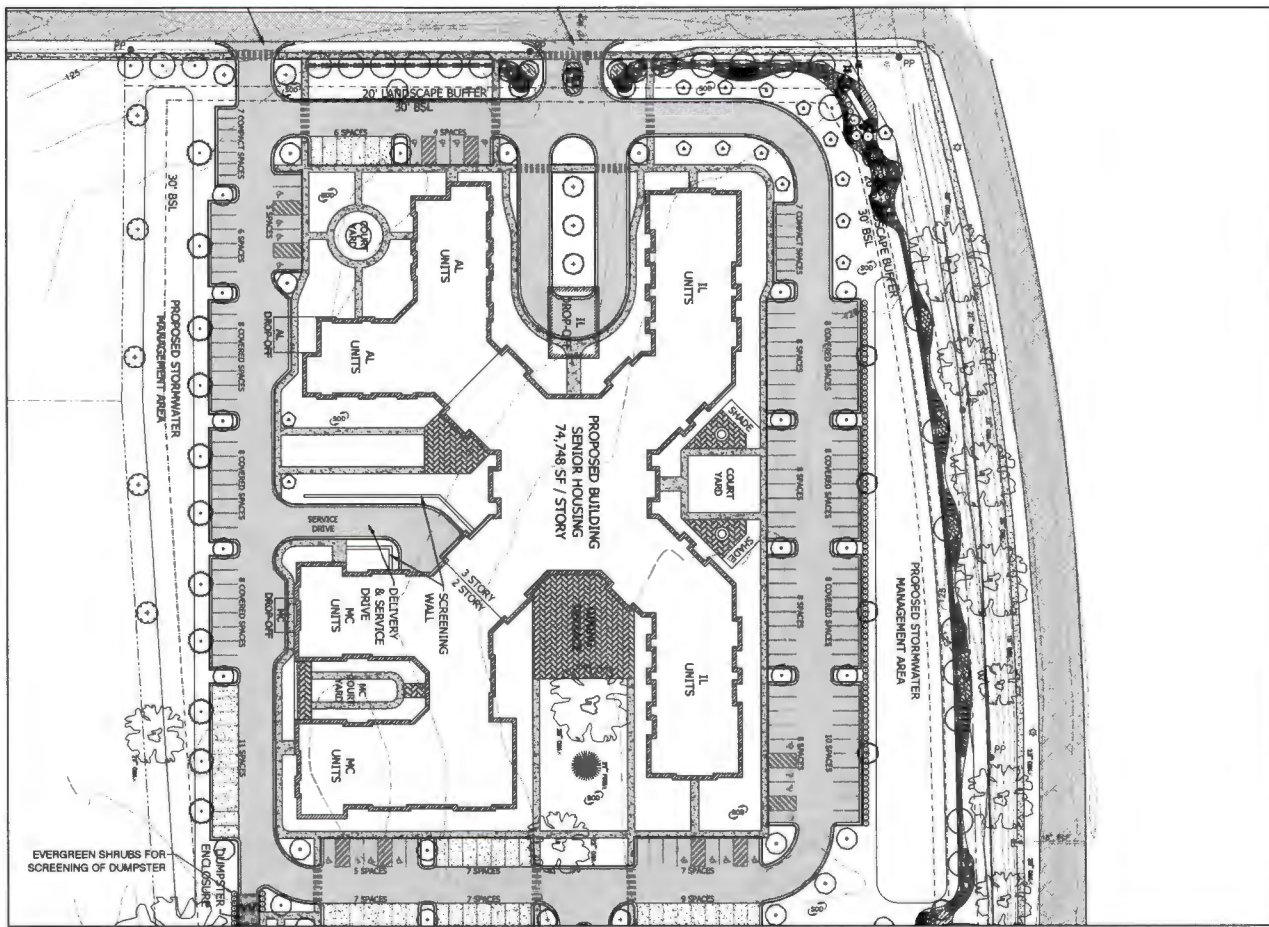

1 LANDSCAPE PLANTING ENLARGEMENT PLAN  
Scale: 1" = 10'

**was DESIGN**  
landscape architecture  
and planning  
10000 Highway 100  
Suite 100  
Fairhope, Alabama 36525  
Phone: 251-494-4422  
Fax: 251-494-4423  
www.was-design.com

**NOT**  
FOR CONSTRUCTION  
THIS PLAN HAS NOT BEEN  
APPROVED BY THE SUBJECT  
TO COUNCIL

A Landscape Development Plan for  
**The Reserve at Fairhope**  
Fairhope, Alabama

DATE	REVISION / REMARKS
08.08.10	ADDED SIGNAGE
08.18.10	REV. SIGNAGE
11.18.10	REV. SIGNAGE

DATE	REVISION
07/10/10	UPDATES
08/02/10	REVISED
08/26/10	REVISED



**LANDSCAPE  
PLANTING  
ENLARGEMENT  
PLAN**

Plan No. **LP200**

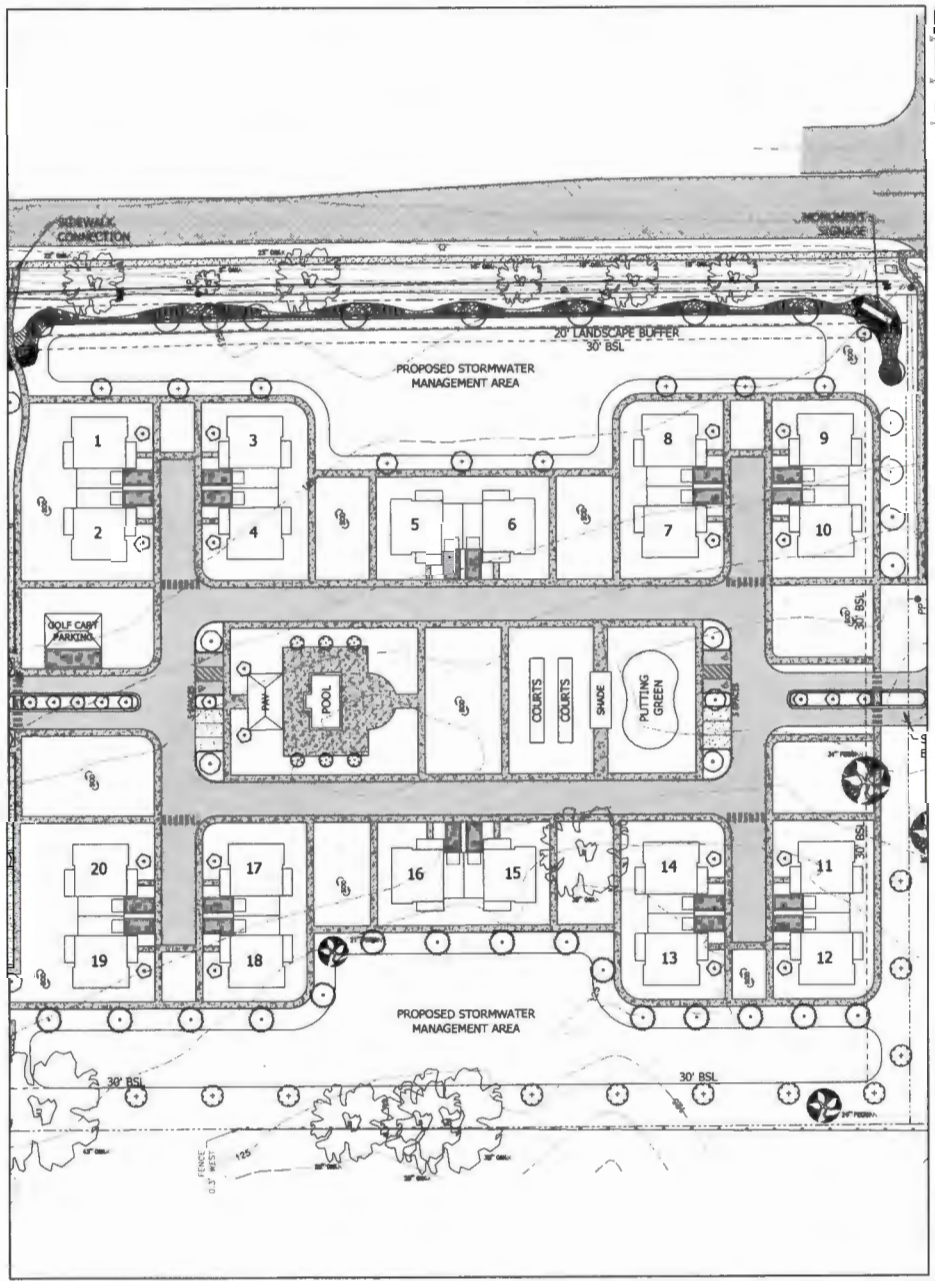

1 LANDSCAPE PLANTING ENLARGEMENT PLAN

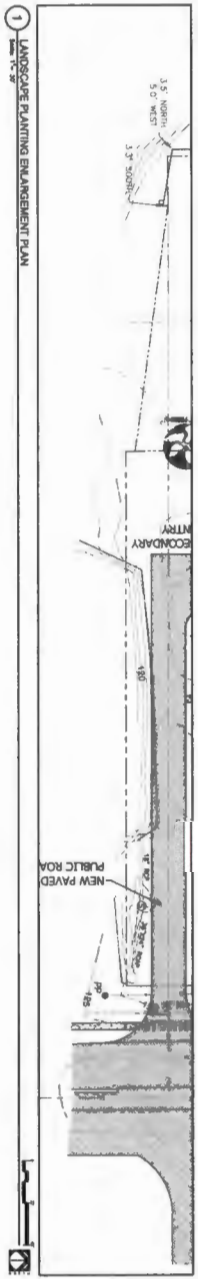

① LANDSCAPE PLANTING ENGAGEMENT PLAN



**NOT**  
FOR CONSTRUCTION

A Landscape Development Plan for  
**The Reserve at Fairhope**  
 Fairhope, Alabama

DATE	12/15/2011
SCALE	AS SHOWN
PROJECT	THE RESERVE AT FAIRHOPE
CLIENT	THE RESERVE AT FAIRHOPE
DESIGNED BY	W&S DESIGN
CHECKED BY	W&S DESIGN
APPROVED BY	W&S DESIGN
DATE	12/15/2011

LANDSCAPE  
 PLANTING  
 ENGAGEMENT  
 PLAN

LP202



**NOT FOR CONSTRUCTION**  
THESE PLANS HAVE NOT BEEN APPROVED AND ARE SUBJECT TO CHANGE

A Landscape Development Plan for  
**The Reserve at Fairhope**  
Fairhope, Alabama

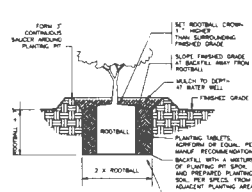

1 SHRUB PLANTING  
1" = 1'-0"

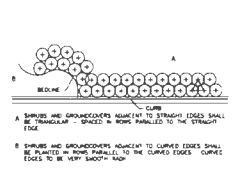

2 TYPICAL PLANT SPACING  
NOT TO SCALE

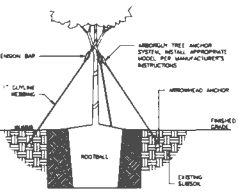

3 TREE PLANTING - GUY STRAP  
1" = 1'-0"

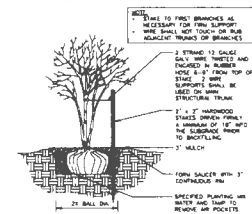

4 MULTI-TRUNK TREE STAKING  
1" = 1'-0"

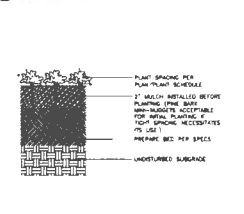

5 GROUND COVER PLANTING  
1" = 1'-0"

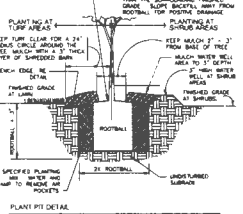

6 TRENCH EDGE  
1" = 1'-0"

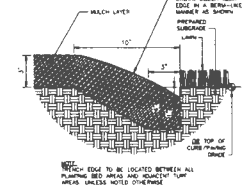

7 GENERAL PLANTING NOTES  
1" = 1'-0"

**GENERAL PLANTING NOTES**

- CONTRACTOR SHALL BE RESPONSIBLE FOR THE SITE INSPECTION PRIOR TO LANDSCAPE CONSTRUCTION AND INSTALLATION IN ORDER TO ACCURATELY VERIFY ALL EXISTING UNDERGROUND UTILITIES BEFORE BEGINNING CONSTRUCTION.
- CONTRACTOR SHALL BE RESPONSIBLE FOR PROTECTION OF LANDSCAPE UTILITIES AT ALL TIMES. LANDSCAPE CONTRACTOR TO COORDINATE SAFE STAGING AREA WITH EXISTING CONTRACTOR AND OWNER.
- CONTRACTOR SHALL SUBMIT A PLANT MATERIAL INCLUDING GRASS, FOR SOIL CONDUCTIVITY CALLS AND SOIL PLANTING MEDIA TO THE PROJECT AS PART OF THE PRELIMINARY LANDSCAPE INSTALLATION AND MAINTENANCE PLAN. ALL AREAS IMPACTED NEARLY BY CONSTRUCTION PROCESS SHALL BE RETURNED TO ORIGINAL CONDITION OR BETTER PRIOR TO SUBSEQUENT CONSTRUCTION.
- LANDSCAPE AREA SHALL BE PREPARED TO RECEIVE 1/2\"/>

**GENERAL PLANTING NOTES**

- CONTRACTOR SHALL BE RESPONSIBLE FOR THE SITE INSPECTION PRIOR TO LANDSCAPE CONSTRUCTION AND INSTALLATION IN ORDER TO ACCURATELY VERIFY ALL EXISTING UNDERGROUND UTILITIES BEFORE BEGINNING CONSTRUCTION.
- CONTRACTOR SHALL BE RESPONSIBLE FOR PROTECTION OF LANDSCAPE UTILITIES AT ALL TIMES. LANDSCAPE CONTRACTOR TO COORDINATE SAFE STAGING AREA WITH EXISTING CONTRACTOR AND OWNER.
- CONTRACTOR SHALL SUBMIT A PLANT MATERIAL INCLUDING GRASS, FOR SOIL CONDUCTIVITY CALLS AND SOIL PLANTING MEDIA TO THE PROJECT AS PART OF THE PRELIMINARY LANDSCAPE INSTALLATION AND MAINTENANCE PLAN. ALL AREAS IMPACTED NEARLY BY CONSTRUCTION PROCESS SHALL BE RETURNED TO ORIGINAL CONDITION OR BETTER PRIOR TO SUBSEQUENT CONSTRUCTION.
- LANDSCAPE AREA SHALL BE PREPARED TO RECEIVE 1/2\"/>

Number	Revision / Description
01.00.00	CLIENT REVIEW
02.00.00	CFP REVISION
03.00.00	CFP REVISION
04.00.00	CFP REVISION
05.00.00	CFP REVISION
06.00.00	CFP REVISION
07.00.00	CFP REVISION
08.00.00	CFP REVISION
09.00.00	CFP REVISION
10.00.00	CFP REVISION
11.00.00	CFP REVISION
12.00.00	CFP REVISION
13.00.00	CFP REVISION
14.00.00	CFP REVISION
15.00.00	CFP REVISION
16.00.00	CFP REVISION
17.00.00	CFP REVISION
18.00.00	CFP REVISION
19.00.00	CFP REVISION
20.00.00	CFP REVISION
21.00.00	CFP REVISION
22.00.00	CFP REVISION
23.00.00	CFP REVISION
24.00.00	CFP REVISION
25.00.00	CFP REVISION
26.00.00	CFP REVISION
27.00.00	CFP REVISION
28.00.00	CFP REVISION
29.00.00	CFP REVISION
30.00.00	CFP REVISION



**ORDINANCE NO. \_\_\_\_**

**AN ORDINANCE TO AMEND ORD. NO. 1312 AND TO  
REPEAL AND REPLACE ORDINANCE NO. 1468, KNOWN AS  
THE TOWING AND RECOVERY ROTATION ORDINANCE**

**BE IT ORDAINED BY THE GOVERNING BODY OF THE CITY OF FAIRHOPE,  
ALABAMA,** as follows:

Section 1. The City of Fairhope, Alabama, Ordinance No. 1312, Section 16, and Code of Ordinance Section 22-56, is hereby amended to reflect the following changes and additions:

**Amend the following:**

**SECTION 16. MAXIMUM ALLOWABLE TOWING/STORAGE FEES:**

No tow truck company which qualifies for the rotation list of the Fairhope Police Department shall charge any fee in excess of amounts set forth herein for calls referred by a police dispatcher.

- A.) One hundred seventy five (\$175.00) dollars charge for each vehicle towed from one point in the city or jurisdiction to another point therein, for any vehicle with a gross vehicle weight rating (GVWR) of 10,000 pounds or less.
  - 1. In addition to A.) above, any service call which requires more than one (1) hour on scene, shall be permitted an additional One hundred seventy five (\$175.00) dollars per hour charge.
  - 2. No added towing charges will be allowed for moving the towed vehicle to any destination required by owner within the city or jurisdiction, but three dollars and fifty cents (\$3.50) per mile charge will be allowed for one way towing outside the police jurisdiction, to tow a vehicle into the jurisdiction from outside, or to tow a vehicle from the jurisdiction to another destination as requested by the vehicle owner.
  
- B.) Four hundred (\$400.00) dollars charge for each vehicle towed from one point in the city or jurisdiction to another point therein, for any vehicle with a gross vehicle weight rating (GVWR) of 10,001 and/or greater (10,001 - greater).
  - 1. In addition to B.) above, any service call which requires more than one (1) hour on scene, shall be permitted an additional four hundred (\$400.00) dollars per hour charge.
  - 2. No added towing charges will be allowed for moving the towed vehicle to any destination required by owner within the city or jurisdiction, but four dollars (\$4.00) for a straight truck or four dollars and fifty cents (\$4.50) for a tractor trailer per mile charge will be allowed for one way towing outside the police jurisdiction, to tow a vehicle into the jurisdiction from outside, or to tow a vehicle from the jurisdiction to another destination as requested by the vehicle owner.
  
- C.) Storage shall be charged as follows:
  - 1. Thirty-five (\$35.00) dollars per day charge for vehicles with a (GVWR) of less than 10,000 pounds.

Ordinance No. \_\_\_\_\_

Page -2-

2. Sixty (\$60.00) dollars per day charge for vehicles with a (GVWR) of 10,001 pounds and/or greater per unit.
3. In addition to storage rates above, ten (\$10.00) dollars per day will be charged for vehicles that require inside storage.

Section 2. The Balance of Section 16 remains as written and codified.

Section 3. The sections, paragraphs, sentences, clauses and phrases of this ordinance are severable, and if any phrase, clause, sentence, paragraph or section of this ordinance shall be declared unconstitutional by a court of competent jurisdiction, then such ruling shall not affect any other paragraphs and sections, since the same would have been enacted by the municipality council without the incorporation of any such unconstitutional phrase, clause, sentence, paragraph or section.

Section 4. This ordinance shall take effect immediately upon its due adoption and publication as required by law.

ADOPTED THIS THE 22ND DAY OF FEBRUARY, 2021

\_\_\_\_\_  
Jack Burrell, Council President

Attest:

\_\_\_\_\_  
Lisa A. Hanks, MMC  
City Clerk

ADOPTED THIS THE 22ND DAY OF FEBRUARY, 2021

\_\_\_\_\_  
Sherry Sullivan, Mayor

**ORDINANCE NO. \_\_\_\_\_**

**AN ORDINANCE TO AMEND ORDINANCE NO. 1266 AND  
TO REPEAL AND REPLACE ORDINANCE NO. 1608  
FAIRHOPE CODE OF ORDINANCES:  
ARTICLE VI, GARBAGE AND TRASH  
COLLECTION AND DISPOSAL, SECTION 21-75**

BE IT ORDAINED BY THE GOVERNING BODY OF THE CITY OF FAIRHOPE, ALABAMA as follows:

Section 1. The Code of Ordinance, City of Fairhope, Alabama, Article VI, Section 21-75, is hereby amended to reflect the following:

**Sec. 21-75. - Rates.**

(a) In the exercise of the police power of the city and for the purpose of enabling the city to perform a governmental function, there is hereby fixed the following garbage service fees for every occupant within the city:

<b><u>RESIDENTIAL</u></b>	<b><u>PER MONTH</u></b>
Single Family	\$ 20.00
Apartment House	\$ 20.00
House Trailer	\$ 20.00
Backdoor Service	\$ 23.00
<b><u>NONRESIDENTIAL</u></b>	<b><u>PER MONTH</u></b>
Base Rate Customer (1 – 96 Gal. Receptacle Serviced as required - Minimum 2X per week)	\$ 25.00
Each Additional 96 Gal. Receptacle	\$ 5.00
Example – 3 Receptacles Serviced 3 times/week	\$ 40.00

(b) Nothing shall prevent an occupant from contracting for garbage service with other licensed collectors within the city; however, the minimum monthly charge must be paid the city by every occupant.

(c) Acquiring garbage containers. Newly annexed properties or newly built homes may acquire a garbage container by contacting the utilities department at city hall and paying a deposit fee set by the current deposit rate. At time of turning utilities on and paying deposits, residents may sign up for a forty-eight-gallon, sixty-four-gallon, and ninety-six-gallon container. The container will have an assigned serial number to the particular address.

(d) Alleyway services. Garbage may be serviced in alleyways but may incur additional charges if the alleys or containers are not accessible to the automated garbage truck. Rates in these areas could be higher if a special truck is needed to service garbage.

Section 2. The above amended garbage rates shall go into effect on April 1, 2021.

Ordinance No. \_\_\_\_\_  
Page -2-

Section 3. Ordinance No. 1608 is hereby repealed; and Ordinance No. 1266 is hereby amended as stated above.

Section 4. This ordinance shall take effect on April 1, 2021 upon its due adoption and publication as required by law.

ADOPTED THIS 22ND DAY OF FEBRUARY, 2021

\_\_\_\_\_  
Jack Burrell, Council President

ATTEST:

\_\_\_\_\_  
Lisa A. Hanks, MMC  
City Clerk

ADOPTED THIS 22ND DAY OF FEBRUARY, 2021

\_\_\_\_\_  
Sherry Sullivan, Mayor

Proposed: Rates shall go into effect on the first billing cycle after March 31, 2021.

Residential Service	Per Month (starting)	
	Jan. 01, 2020	April. 01, 2021
Single family	\$15.80	\$20.00
Apartment house	\$15.80	\$20.00
House trailer	\$15.80	\$20.00
Backdoor / Handicapped service	\$20.00	\$20.00

Business Service	Per Month (starting)	
	Jan. 01, 2020	April 01, 2021
Base rate customer (1—96 gal. receptacle serviced as required—Minimum 2X per week)	\$20.25	\$25.00
Each additional 96 gal. receptacle ( Per Month )	\$5.00	\$5.00
Example: 3 receptacles serviced 3 times/week	\$35.25	\$40.00

**ORDINANCE NO. 1608**

**AN ORDINANCE TO AMEND ORDINANCE NO. 1266  
AND FAIRHOPE CODE OF ORDINANCES:  
ARTICLE VI, GARBAGE AND TRASH  
COLLECTION AND DISPOSAL, SECTION 21-75**

BE IT ORDAINED BY THE GOVERNING BODY OF THE CITY OF FAIRHOPE, ALABAMA as follows:

Section 1. The Code of Ordinance, City of Fairhope, Alabama, Article VI, Section 21-75, is hereby amended to reflect the following Garbage Rates:

<u>RESIDENTIAL</u>	<u>PER MONTH (Starting)</u>		
	Jan. 01, 2018	Jan. 01, 2019	Jan. 01, 2020
Single Family	\$ 13.80	\$ 14.80	\$ 15.80
Apartment House	\$ 13.80	\$ 14.80	\$ 15.80
House Trailer	\$ 13.80	\$ 14.80	\$ 15.80
Backdoor Service	\$ 21.00	\$ 22.00	\$ 23.00

<u>NONRESIDENTIAL</u>	<u>PER MONTH (Starting)</u>		
	Jan. 01, 2018	Jan. 01, 2019	Jan. 01, 2020
Base Rate Customer (1 - 96 Gal. Receptacle Serviced as required - Minimum 2X per week)	\$ 18.25	\$ 19.25	\$ 20.25
Each Additional 96 Gal. Receptacle	\$ 5.00	\$ 5.00	\$ 5.00
Example - 3 Receptacles Serviced 3 times/week	\$ 28.25	\$ 29.25	\$ 30.25

Balance of Section 21-75 remains as written and codified.

Section 2. The above amended garbage rates shall go into effect on the first billing cycle after 1 January 2018.

Section 3. By January 1, 2019, all nonresidential customers shall be converted to the standard City of Fairhope garbage receptacles - 96-gallon Auto Cart. One (1) new cart shall be provided at no charge under contract and each additional cart shall be a onetime charge of \$65.00 per cart.

Section 4. Ordinance No. 1044 is hereby repealed; and Ordinance No. 1266 is hereby amended as stated above.

Section 5. This ordinance shall take effect immediately upon its due adoption and publication as required by law.

ADOPTED THIS 11TH DAY OF DECEMBER, 2017

  
Karin Wilson, Mayor

ATTEST:

  
Lisa A. Hanks, MMC  
City Clerk

Ord. No. 1608 Published in  
FAIRHOPE COURIER  
on  City Clerk

**RESOLUTION NO. \_\_\_\_\_**

**RESOLUTION RESCINDING THE AWARD OF RFP PS007-20,  
RESOLUTION NO. 3926-20, FOR THE PURPOSE RESCORING  
THE PROPOSALS DUE A DISCREPANCY  
IN THE RATING CRITERIA**

WHEREAS, the City of Fairhope was awarded a RESTORE Act Direct Component Subrecipient Grant (#S1P17-FACP) from the Alabama Department of Conservation and Natural Resources (ADCNR) on April 16, 2020; and

WHEREAS, the project requires Geographic Information System Services, and the City did solicit Requests for Proposals (RFP PS007-20) in accordance with applicable federal, state and local laws, codes, regulations, ordinances, etc. including but not limited to all executive orders (EO), Office of Management and Budget (OMB) requirements, and U.S. Treasury Regulations; and

WHEREAS, the City did award the contract for Geographic Information System Services (RFP PS007-20) via Resolution Number 3926-20 at the regularly held Council Meeting on December 23, 2020, with the condition that the award was subject to review and approval by ADCNR prior to contract execution; and

WHEREAS, following a review by ADCNR, on February 2, 2021, ADCNR has requested that the City rate the proposals again due to a discrepancy in one rating criteria listed in the RFP PS007-20;

NOW, THEREFORE IT BE RESOLVED BY THE City of Fairhope, IN REGULAR SESSION ASSEMBLED, that the City rescinds the contract for RFP PS007-20 that was awarded to Goodwyn, Mills and Cawood, Inc. on December 23, 2020 upon the request of ADCNR;

BE IT FURTHER RESOLVED BY THE City of Fairhope, that the City's Evaluation Committee will rescore the proposals utilizing the revised rating criteria as outlined in the RFP PS007-20 and approved by ADCNR.

DULY ADOPTED THIS 22ND DAY OF FEBRUARY, 2021

\_\_\_\_\_  
Jack Burrell, Council President

Attest:

\_\_\_\_\_  
Lisa A. Hanks, MMC  
City Clerk



**RESOLUTION NUMBER 3926-20**

**AWARDING THE RFQ PS007-20 GEOGRAPHIC INFORMATION  
SYSTEM (GIS) SERVICES CONTRACT  
FOR THE ALABAMA DEPARTMENT OF CONSERVATION  
AND NATURAL RESOURCES GRANT #S1P17-FACP  
(RESTORE ACT- FAIRHOPE AREA COMMUNITY-BASED  
COMPREHENSIVE LAND USE PLAN)**

WHEREAS, the City of Fairhope was awarded a RESTORE Act Direct Component Subrecipient Grant from the Alabama Department of Conservation and Natural Resources (ADCNR) on April 16, 2020; and

WHEREAS, the project requires Geographic Information System Services and the City did solicit Requests for Qualifications (RFQ PS007-20) in accordance with applicable federal, state and local laws, codes, regulations, ordinances, etc., including, but not limited to all executive orders (EO), Office of Management and Budget (OMB) requirements, and U.S. Treasury Regulations; and

WHEREAS, the City did receive five (5) proposals from Qualified Firms for said services which were opened and reviewed, and the City's Evaluation Committee selected the two (2) most qualified firms to make presentations on November 10, 2020, and subsequently rated them according to the rating criteria; and

WHEREAS, the City's Evaluation Committee determined Goodwyn, Mills and Cawood, Inc. to be the most qualified firm and recommends that this firm be selected for said services; and

WHEREAS, the amount obligated for Geographic Information System Services of the Subrecipient Grant by the U.S. Department of Treasury is Ninety-Seven thousand, five-hundred dollars (\$97,500.00); and

WHEREAS, One hundred percent (100%) of the Geographic Information System Services fees will be paid for with grant funds made available through the Subrecipient Grant Agreement #S1P7-FACP with ADCNR.

**THEREFORE, BE IT RESOLVED BY THE City of Fairhope, IN REGULAR SESSION ASSEMBLED, that by this Resolution the City of Fairhope awards the contract for Geographic Information System Services (RFQ PS007-20) for ADCNR Grant #S1P7-FACP to Goodwyn, Mills and Cawood, Inc., subject to review and approval by ADCNR and City Attorney prior to execution; and**

**Resolution No. 3926-20**

**Page – 2-**

BE IT FURTHER RESOLVED BY THE City of Fairhope, that the City will initially award the contract for a fee not-to-exceed \$97,500.00 of grant funds and authorize the Mayor to execute a contract with Goodwyn, Mills and Cawood, Inc. for RFP PS007-20 Geographic Information System Services for Comp Plan ADCNR Grant #S1P17-FACP (RESTORE Act).

DULY ADOPTED THIS 23RD DAY OF DECEMBER, 2020

  
\_\_\_\_\_  
Jack Burrell, Council President

Attest:

  
\_\_\_\_\_  
Lisa A. Hanks, MMC  
City Clerk

**CITY OF FAIRHOPE EVALUATION**  
**BID NO: RFP 007-20**  
**BID NAME: GIS Services**  
**ADCNR Grant #S1P17-FACP**

**ORIGINAL RATING CRITERIA**

Criteria
<b>Criteria 1</b> Qualifications, knowledge and expertise regarding the proposed Scope of Work
<b>Criteria 2</b> Resources and availability
<b>Criteria 3</b> Experience of proposed key personnel
<b>Criteria 4</b> Understanding and familiarity with the needs and environment of the community
<b>Criteria 5</b> Previous experience in working with locality
<b>Total Weighted Score</b>

Weight	Rating (0-100)	Weighted Score
20%		0
20%		0
20%		0
20%		0
20%		0
<b>Total Weighted Score</b>		<b>0</b>

CITY OF FAIRHOPE EVALUATION  
 BID NO: RFP 007-20  
 BID NAME: GIS Services  
 ADCNR Grant #S1P17-FACP

**REVISED RATING CRITERIA**

Criteria
<b>Criteria 1</b> Qualifications, knowledge and expertise regarding the proposed Scope of Work
<b>Criteria 2</b> Resources and availability
<b>Criteria 3</b> Experience of proposed key personnel
<b>Criteria 4</b> Previous experience in working with locality
<b>Criteria 5</b> Cost of services to be provided
<b>Total Weighted Score</b>

Weight	Rating (0-100)	Weighted Score
20%		0
20%		0
20%		0
20%		0
20%		0
<b>Total Weighted Score</b>		<b>0</b>

**CITY OF FAIRHOPE EVALUATION**  
**BID NO: RFP 007-20**  
**BID NAME: GIS Services**  
**ADCNR Grant #S1P17-FACP**

**REVISED RATING CRITERIA**

Criteria	Weight	Rating (0-100)	Weighted Score
<b>Criteria 1</b> Qualifications, knowledge and expertise regarding the proposed Scope of Work	20%		0
<b>Criteria 2</b> Resources and availability	20%		0
<b>Criteria 3</b> Experience of proposed key personnel	20%		0
<b>Criteria 4</b> Previous experience in working with locality	20%		0
<b>Criteria 5</b> Cost of services to be provided	20%		0
<b>Total Weighted Score</b>			<b>0</b>

**RESOLUTION NO. \_\_\_\_\_**

**BE IT RESOLVED BY THE GOVERNING BODY OF THE CITY OF FAIRHOPE, ALABAMA,** That the City Council approves the selection of Hope Hicks with Ball, Ball, Matthews & Novak for HR related Consulting Services; and hereby authorizes Mayor Sherry Sullivan to execute the associated contract/engagement letter for an additional \$5,000.00, bringing the total with a not-to-exceed to \$10,000.00.

DULY ADOPTED THIS 22ND DAY OF FEBRUARY, 2021

\_\_\_\_\_  
Jack Burrell, Council President

Attest:

\_\_\_\_\_  
Lisa A. Hanks, MMC  
City Clerk

**RESOLUTION NO. 3678-20**

**BE IT RESOLVED BY THE GOVERNING BODY OF THE CITY OF FAIRHOPE, ALABAMA**, that the City Council approves the selection of Hope Hicks with Ball, Ball, Matthews & Novak for HR related Consulting Services; and hereby authorizes Mayor Karin Wilson to execute the associated contract with a not-to-exceed limit of \$5,000.00.

DULY ADOPTED THIS 6TH DAY OF APRIL, 2020

---

Karin Wilson, Mayor

Attest:

---

Lisa A. Hanks, MMC  
City Clerk

**RESOLUTION NO. \_\_\_\_\_**

**AUTHORIZING THE SUBMISSION OF AN FY2021  
RECREATIONAL TRAILS PROGRAM GRANT APPLICATION TO THE  
ALABAMA DEPARTMENT OF ECONOMIC AND COMMUNITY AFFAIRS**

WHEREAS, the Alabama Department of Economic and Community Affairs (ADECA) is accepting grant applications for the FY 2021 Recreational Trails Program (RTP) grants; and

WHEREAS, the City of Fairhope has identified a need to construct a multi-use recreational trail, with trailhead facilities, for mountain biking and pedestrian use, located at the northern portion of the Triangle property, just north of Veterans Drive; and

WHEREAS, the total project cost estimate is \$550,000.00 and the City is requesting \$400,000.00 in FY 2021 RTP funds and, if the grant is funded, the City will provide \$150,000.00 (27%) in local matching funds through a cash contribution;

THEREFORE, BE IT RESOLVED BY THE City of Fairhope, IN REGULAR SESSION ASSEMBLED, that by this Resolution the City of Fairhope authorizes submission of a grant application to ADECA requesting an FY 2021 RTP grant and authorizes the Mayor to sign the required grant application documents on behalf of the City.

DULY ADOPTED THIS 22ND DAY OF FEBRUARY, 2021

\_\_\_\_\_  
Jack Burrell, Council President

Attest:

\_\_\_\_\_  
Lisa A. Hanks, MMC  
City Clerk



**Public Works Director Estimated Costs**

**ADECA - The Recreational Trails Program (RTP) - FY2021 FUNDING CYCLE**

**North Triangle Property - New Multi - Use Trails & Sidewalk Project**

Construction Estimate					
Construction of 7920 linear feet (1.5 Miles) of new 8 foot wide Multi-Use Trails, 1220 linear feet of new 6 foot concrete sidewalk, Trail Head Parking, Restrooms and Kiosk					
Item #	Description	Unit	Quantity	Unit Price	Amount
1	Clearing and Grubbing	LS	1	\$25,000.00	\$25,000.00
2	Unclassified Excavation	Yd <sup>3</sup>	940	\$6.00	\$5,640.00
3	Borrow Excavation (A-2-4(0) or A-4(0))	Yd <sup>3</sup>	470	\$12.00	\$5,640.00
4	Crushed Aggregate Base Course, Type A (825A), Plant Mixed, 6" Minimum Compacted Thickness - per SY	SY	7635	\$22.50	\$171,787.50
5	Steel Landscape Edging, hot-rolled, standard flexible carbon steel, Hot-Dipped Galvanized finish, fabricated in sections with stake pockets stamped, 3/16" x 6"	LF	15840	\$5.00	\$79,200.00
6	Concrete Sidewalk, 6-Foot, 3000 PSI, 4" thick (1220 linear feet total)	SY	813	\$26.25	\$21,341.25
7	8' Wooden Bridge Boardwalk (Including all timber, galvanized hardware, anchors and Paint) (509D-000)	LF	120	\$225.00	\$27,000.00
8	Mobilization (600A-000)	LS	1	\$25,000.00	\$25,000.00
9	24" RCP Side Drain (Driveway Culvert)	LF	32	\$65.00	\$2,080.00
10	Slope Concrete Paving (6" HC Parking Apron)	Yd <sup>3</sup>	43	\$45.25	\$1,945.75
11	Sloped Paved Headwalls	Each	2	\$750.00	\$1,500.00
12	Concrete Ribbon Curb - 6" Wide	LF	185	\$15.00	\$2,775.00
13	Asphalt wearing surface - 429A 165 #/sy - 1.5" thick - Driveway - Unit Price includes subbase, base processing and paving	Yd <sup>3</sup>	160	\$62.86	\$10,057.60
14	Bathroom - Men/Women - one W.C. & Lavatory per side - 6 foot covered porch, CMU on slab with wood framed roof structure (Turn Key Price)	Each	1	\$75,000.00	\$75,000.00
15	Trail Head Kiosk and Bicycle Repair Station (Turn Key Price)	Each	1	\$12,500.00	\$12,500.00
16	Topsoil, 4" Compacted Thickness (650A-000)	Yd <sup>3</sup>	82	\$15.25	\$1,250.50
17	Seeding (652A-100)	Acre	0.5	\$750.00	\$375.00
18	Solid Sodding (Centipede) (654A-003)	Yd <sup>2</sup>	1101	\$6.50	\$7,156.50
19	Mulching (656A-010)	Acre	0.5	\$900.00	\$450.00
20	Erosion Control Measures (BMP's)	LS	1	\$12,500.00	\$12,500.00
21	Traffic Control Markings, Class 2, Type A (703A-002)	Ft <sup>2</sup>	144	\$12.50	\$1,800.00
22	Project Contingencies	Each	1	\$10,000.00	\$10,000.00
<b>Estimated Construction Cost</b>					<b>\$499,999.10</b>

Professional Services Calculations					
Item #	Description	Unit	Quantity	Unit Price	Amount
1	Engineering Survey & Design (5.0% of Construction)	Each	1	\$24,999.96	\$24,999.96
2	Material Testing (1.0% of Construction)	Each	1	\$4,999.99	\$4,999.99
3	Engineering - CE&I (4.0% of Construction)	Each	1	\$19,999.96	\$19,999.96
<b>Estimated Professional Service Cost</b>					<b>\$49,999.91</b>

<b>Estimated Total Cost (Including Engineering, Survey, Design, Material Testing and CE&amp;I)</b>					<b>\$549,999.01</b>
--	--	--	--	--	---------------------



**Recreational Trails Grant - North Triangle Property - Overall Trail Layout**

Prepared By:	R.D. Johnson, PE	City of Fairhope
Date:	2/9/2021	Scale: N.T.S.
Project No.:	2021-PWI 008	BOUNDARY

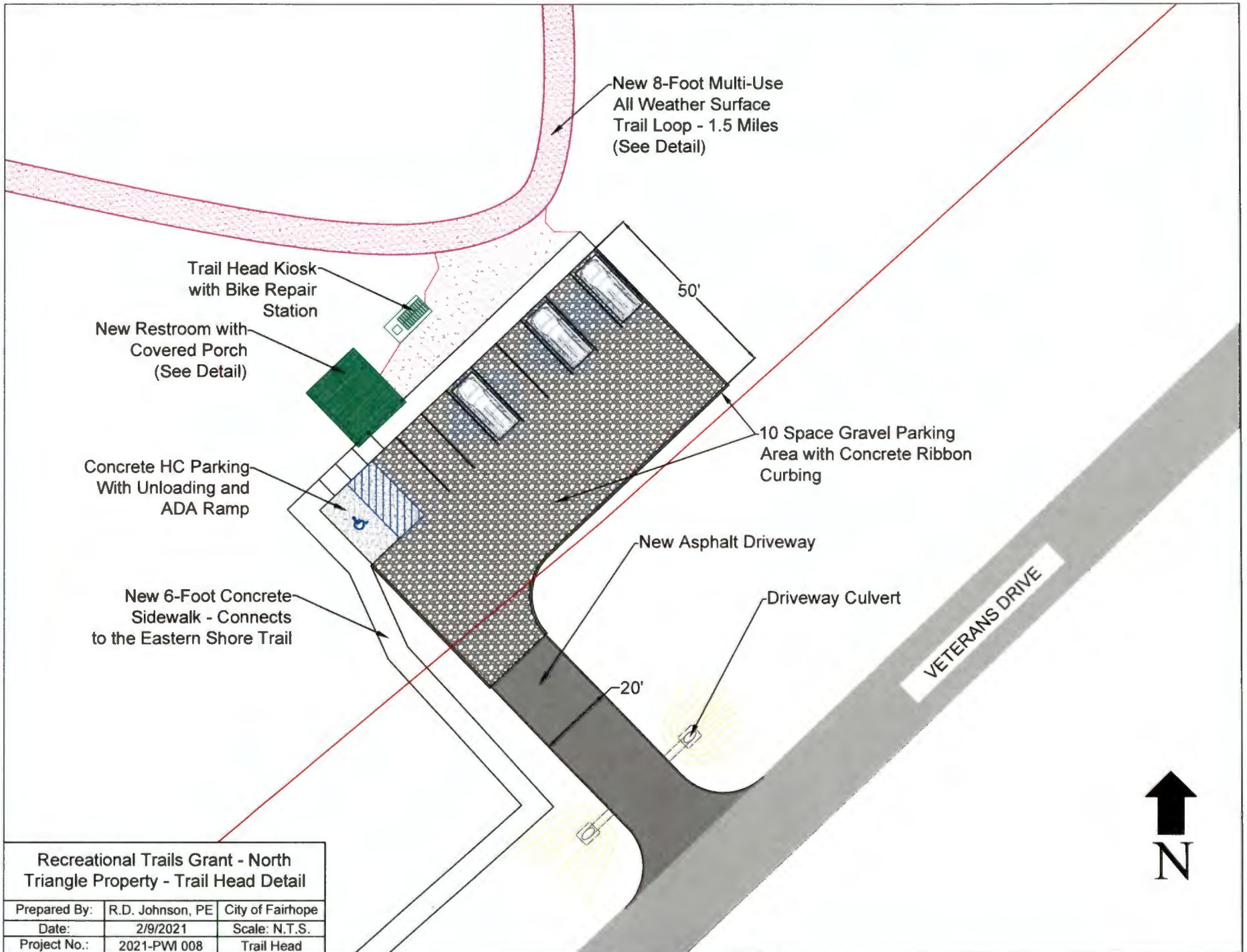

<b>Recreational Trails Grant - North Triangle Property - Trail Head Detail</b>		
Prepared By:	R.D. Johnson, PE	City of Fairhope
Date:	2/9/2021	Scale: N.T.S.
Project No.:	2021-PWI 008	Trail Head

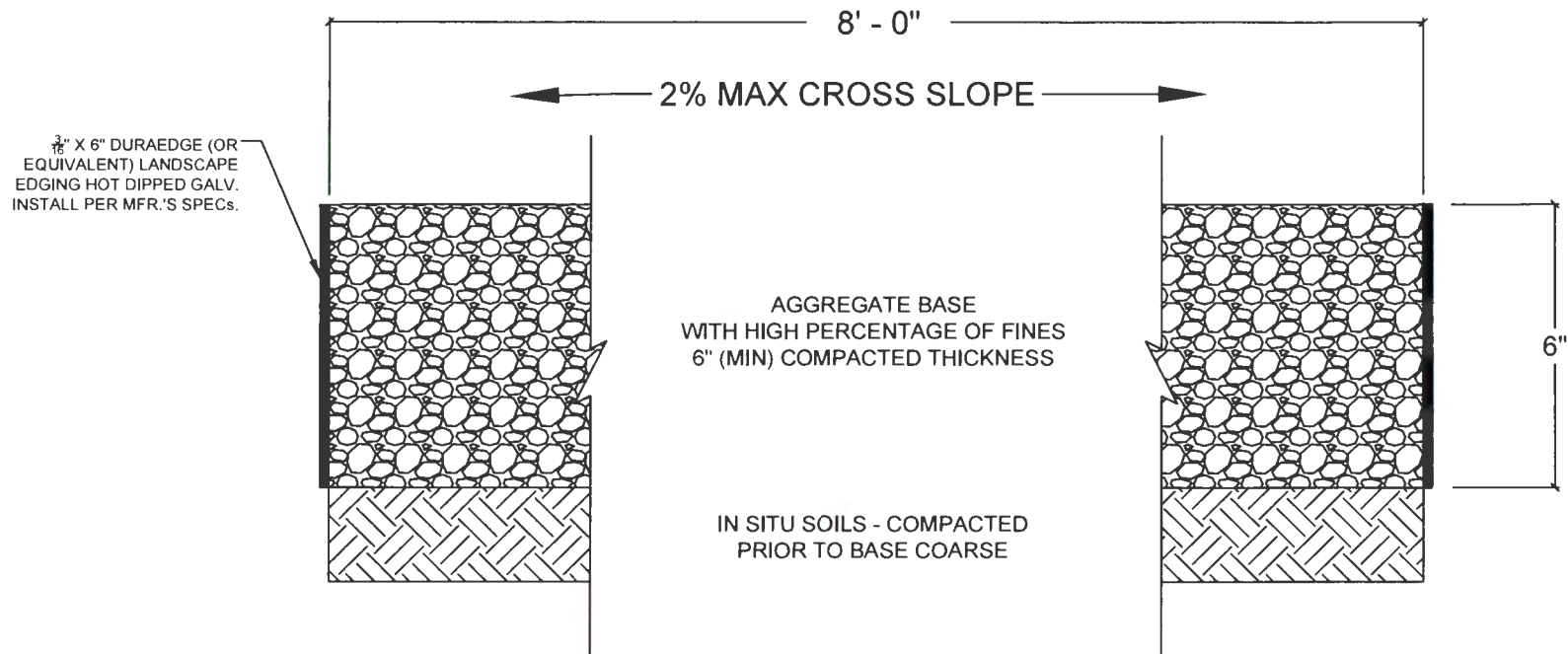

### COMPACTED AGGREGATE TRAIL TYPICAL CROSS SECTION

#### SPECIAL SPECIFICATIONS - COMPACTED AGGREGATE TRAILS

1. DESCRIPTION. Furnish and install aggregate trails and as shown on the plans or as directed.
2. MATERIALS. Provide aggregate base material, necessary subgrade fill material, weed barrier fabric, binding material, and other miscellaneous items as shown on the plans.
3. COLOR. Aggregate Material Color shall be selected by the owner based on aesthetics, price and/or availability.
4. CONSTRUCTION. All materials furnished will be installed as shown on the plans or as directed by the Engineer.
5. Aggregate Base. Place over filter fabric. Remove loose material from the exposed subgrade. Place aggregate in maximum 3 in. deep lifts, wet thoroughly, and let set according to the supplier's instructions.
6. Compact to not less than 90% nor more than 95% of maximum dry density (ASTM D 698) with a roller. Do not use a tamp plate.
7. MEASUREMENT. This item will be measured by Square Yard, complete in place for the project, as shown on the plans.
8. PAYMENT. The work performed and materials furnished in accordance with this item and as provided under "Measurement" will be paid for at the unit price bid of Square Yard for "Aggregate Base". This price is full compensation for furnishing, installing, testing, and for all other materials, labor, tools, equipment, and incidentals.
9. STABILIZER. Aggregate Trail will be installed using TerraKoat EX Stabilizer and Top Coat (or equivalent) - stabilizers shall be used per the manufacturer's directions and application rates. The stabilizers shall be a subsidiary obligation of the Aggregate Base Unit Cost.
10. EDGING. Landscape Edging shall be DuraEdge (or equivalent)  $\frac{3}{8}$ " thick, 6" wide, by 16' length, with 6 stakes (actual coverage 15'-4"), Hot Dipped Galvanized, Comply with ASTM A 569, hot rolled, standard flexible steel.

#### Recreational Trails Grant - North Triangle - Aggregate Trail Details

Prepared By:	R.D. Johnson, PE	City of Fairhope
Date:	2/10/2021	Scale: N.T.S.
Project No.:	2021-PWI 008	Sheet: 3 of 4

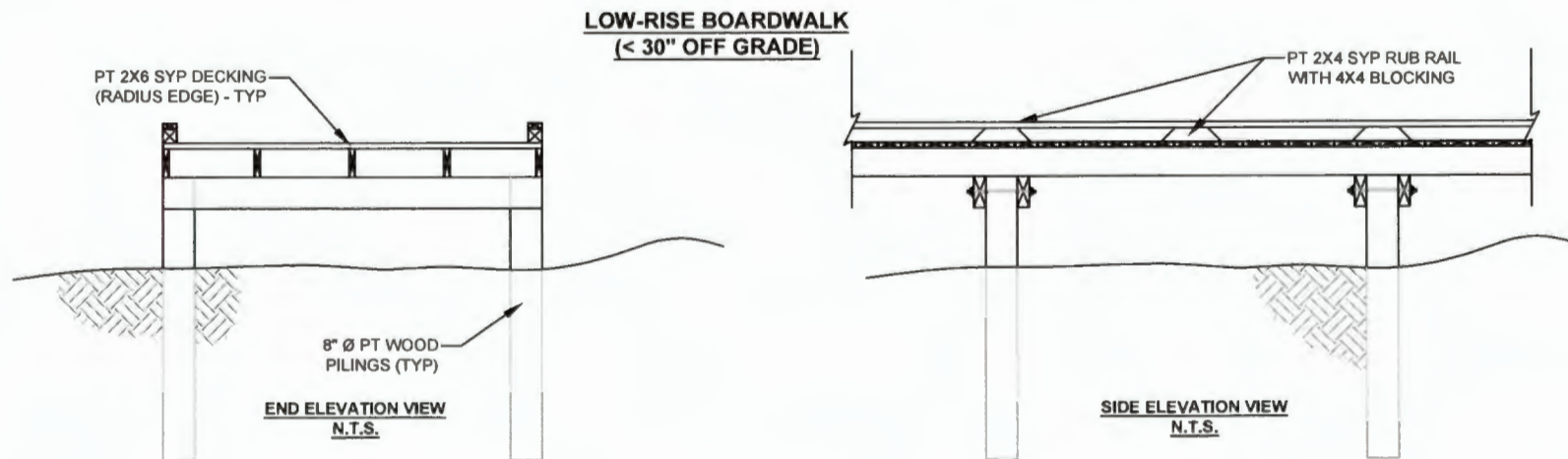
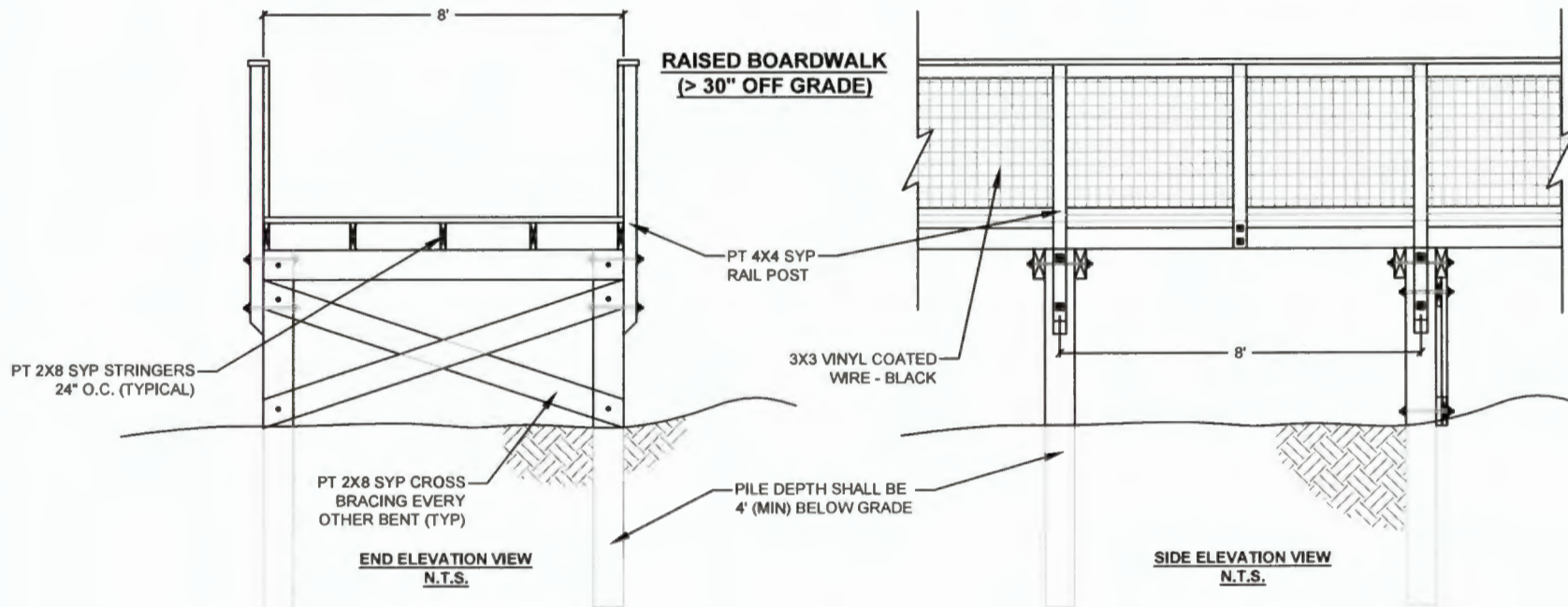

**NOTES:**

1. Boardwalks shall be used in strategic locations to cross drainage ways and other features to allow for their natural function without interference.
2. Boardwalks shall be built with approach and departure ramps that tie into the Decomposed Granite Trails. All boardwalks shall be in full compliance with the Americans With Disabilities Act (ADA).
3. All sections of Boardwalks more than 30' above finished grade shall have handrails as shown, those sections less than 30' off finished grade shall be built with rub rails as shown.

**Recreational Trails Grant - North  
Triangle - Trail Boardwalk Details**

Prepared By:	R.D. Johnson, PE	City of Fairhope
Date:	2/10/2021	Scale: N.T.S.
Project No.:	2021-PWI 008	Sheet: 4 of 4



RTP Bathroom at Trail Head  
Conceptual Drawing

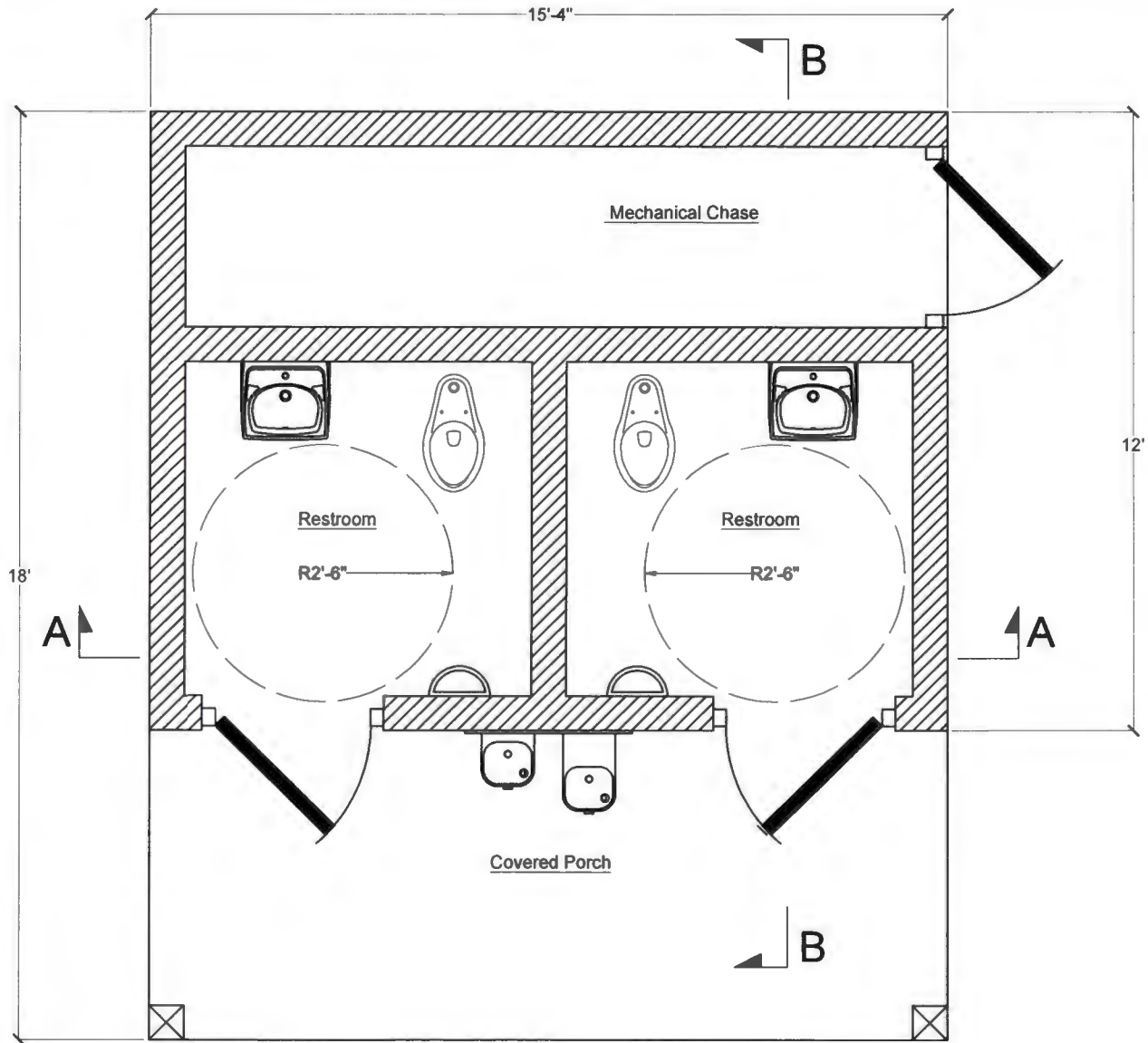

**PLAN VIEW**  
Grant Application Conceptual Drawing

**RTP Grant North Triangle - Trailhead Restroom**

City of Daphne - Public Works Department

Dwg: RDJ

Date: 02/09/2021

Sheet #: 1 of 3

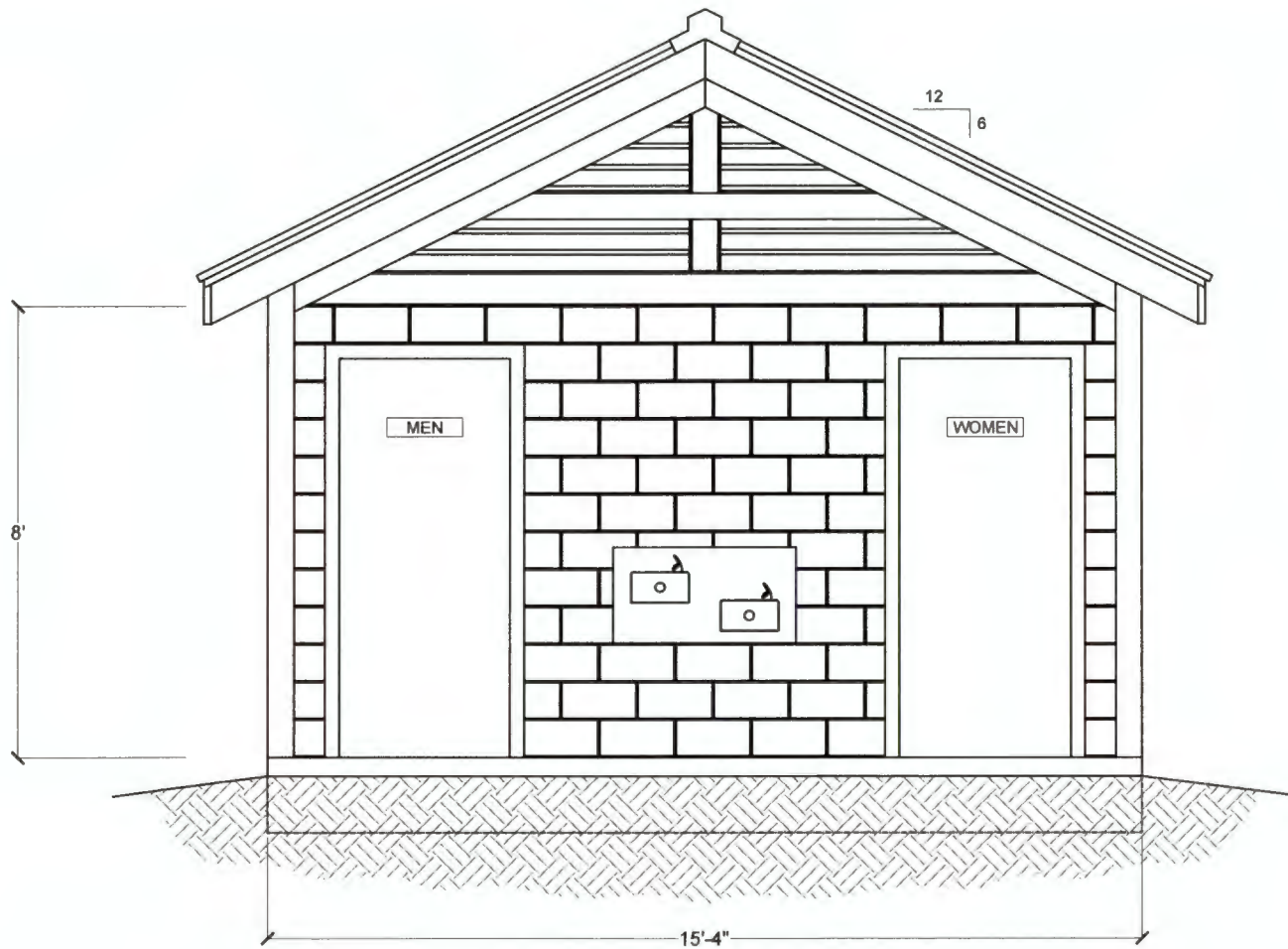

**FRONT ELEVATION VIEW**  
**Grant Application Conceptual Drawing**

<b>RTP Grant North Triangle - Trailhead Restroom</b>		
City of Daphne - Public Works Department		
Dwg: RDJ	Date:02/09/2021	Sheet #: 2 of 3



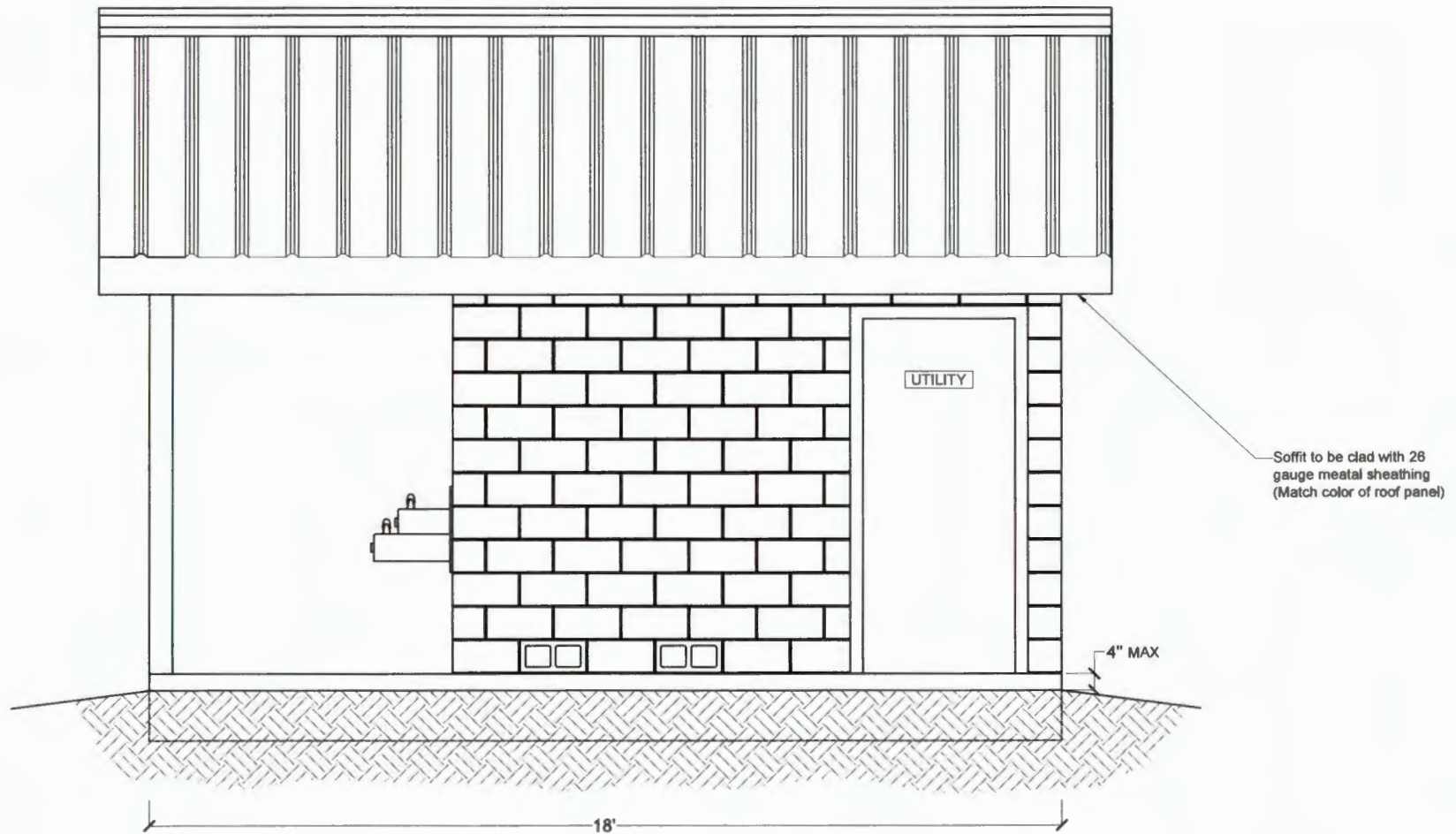

**SIDE ELEVATION VIEW (MECHANICAL ACCESS SIDE)**  
 Grant Application Conceptual Drawing

<b>RTP Grant North Triangle - Trailhead Restroom</b>		
City of Daphne - Public Works Department		
Dwg: RDJ	Date: 02/09/2021	Sheet #: 3 of 3

# KIOSK SCALED DRAWING

Jan. 5, 2009

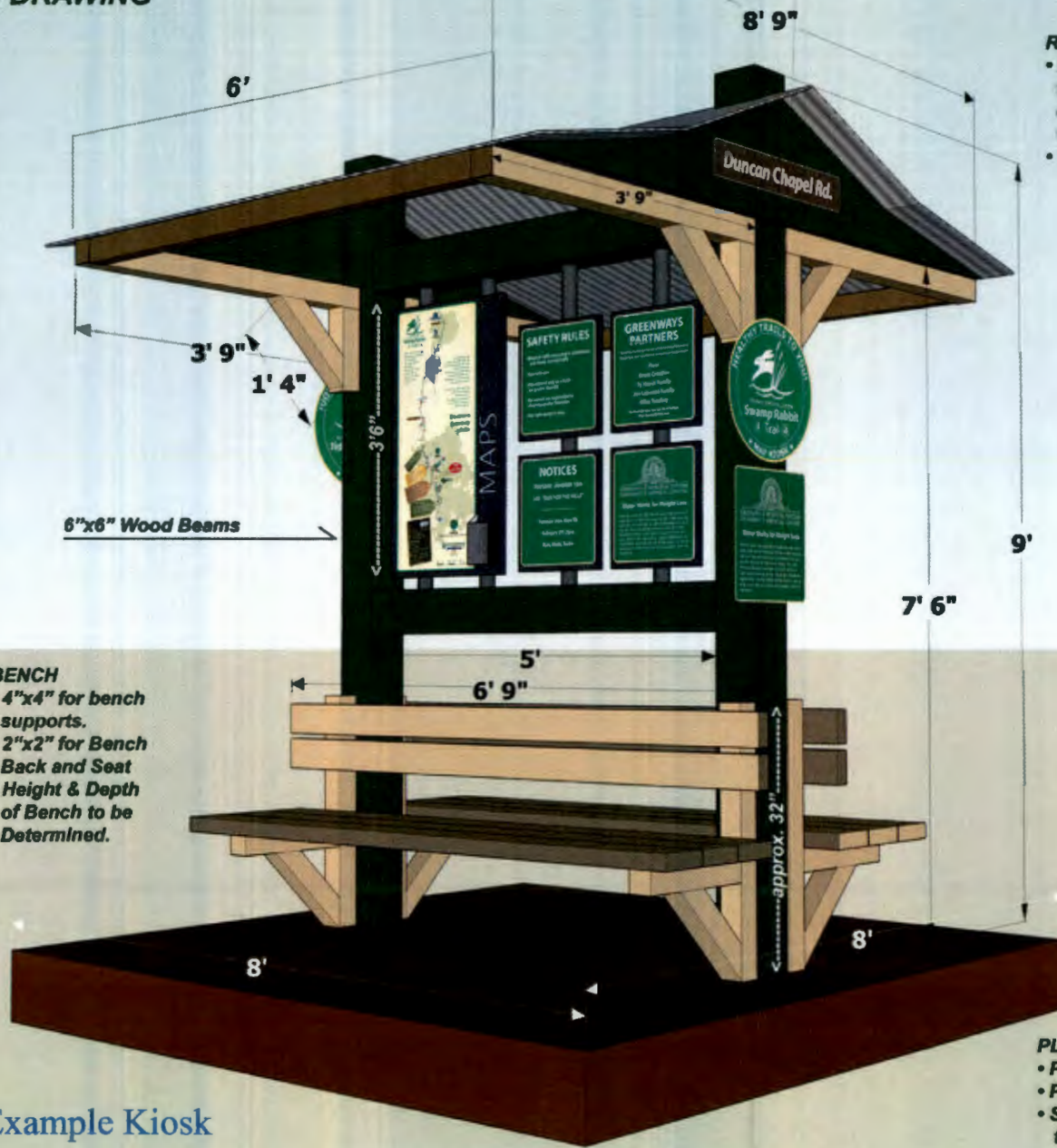

### ROOF:

- Main support beam will extend through roof to give appearance of historic train stations with chimneys.
- Tin Roof



### BENCH

- 4"x4" for bench supports.
- 2"x2" for Bench Back and Seat
- Height & Depth of Bench to be Determined.

### PLATFORM:

- Platform Height 6"-12" inches
- Platform Dimensions 8'x8'
- Slatted wood to allow debris to drop through.

Conceptual Example Kiosk



Patents D680,914 S1 and 9,498,880 B2

## Fixit

The Fixit includes all the tools necessary to perform basic bike repairs and maintenance, from changing a flat to adjusting brakes and derailleurs. The tools are securely attached to the stand with stainless steel cables and tamper-proof fasteners. Hanging the bike from the hanger arms allows the pedals and wheels to spin freely while making adjustments.

Hanger arms accommodate most types of bikes

QR code takes smart phone users to comprehensive bike repair web site

Large surface area for sponsorship, branding, or way-finding signage

Tools are secured with braided stainless steel aircraft cables

Screwdrivers and Allen Wrenches are on swivel connectors for easier use

Includes most commonly used tools for simple bike maintenance

Tamper-resistant fasteners included!

**Tools included:**

- Philips and flat head screwdrivers
- 2.5, 3, 4, 5, 6, 8mm Allen wrenches
- Headset wrench
- Pedal wrench
- 8, 9, 10, 11mm box wrenches
- Tire levers (2)

Add your choice of an Air Kit bike pump (sold separately) to keep your cyclists' tires topped up and ready to roll. The Air Kits feature our new Metal Head™, a sturdy cast aluminum pump head with Presta and Schrader valve compatibility.

*These public bike repair products require occasional maintenance and replacing of parts to remain serviceable.*

## FINISH OPTIONS

### Galvanized



### Stainless



### Powder Coat

White	Black	Light Gray RAL 7042	Deep Red RAL 3003	Yellow RAL 1023
CNH Bright Yellow	Orange RAL 2004	Beige RAL 1001	Iron Gray RAL 7011	Hunter Green RAL 6005
Light Green RAL 6018	Green RAL 6016	Sepia Brown RAL 8014	Bronze	Silver RAL 9007
Dark Purple	Flat Black	Wine Red RAL 3005		

RESOLUTION NO. \_\_\_\_\_

**WHEREAS**, a contract shall be executed between the City of Fairhope and the Baldwin County Economic Development Alliance, Inc., making an appropriation of \$15,000.00 to assist with economic development facilitation within the City of Fairhope. BCDEA is pleased to continue its 20-year relationship with the City of Fairhope. BCEDA's charge is to develop and facilitate new job creation opportunities for all communities in Baldwin County. BCEDA will work with City Leadership to continue to develop new job creation opportunities in but not limited to the following: IT, Software Development, Aerospace, Aviation and Medical sectors. We will continue to work with the Mayor, City Staff and City Council to identify, develop and promote designated areas of Fairhope for future job creation. BCEDA will continue to promote and market the City of Fairhope, advising national and international corporate decision makers of all that Fairhope has to offer them as a top site-selection location. BCEDA will continue to advise and assist the Mayor and City Leaders in developing a place and atmosphere in Fairhope that encourages, fosters, and facilitates entrepreneurship. BCEDA will work with local, regional, and statewide workforce development partners to communicate current and future training and education requirements to Coastal Alabama Community College and The Academy at the Fairhope Airport.

**WHEREAS**, the term of said contract shall be for one (1) year, beginning 1 October 2020 and ending 30 September 2021; but the contract shall be cancelled at any time upon notice.

**WHEREAS**, payment shall be made in the total amount of \$15,000.00 from the City of Fairhope.

**BE IT RESOLVED BY THE GOVERNING BODY OF THE CITY OF FAIRHOPE, ALABAMA**, that Mayor Sherry Sullivan is hereby authorized to sign a contract between the City of Fairhope and the Baldwin County Economic Development Alliance, Inc.

DULY ADOPTED THIS 22ND DAY OF FEBRUARY, 2021

\_\_\_\_\_  
Jack Burrell, Council President

Attest

\_\_\_\_\_  
Lisa A. Hanks, MMC  
City Clerk

**CONTRACT**

STATE OF ALABAMA        )  
                                  :  
COUNTY OF BALDWIN     )

For and in consideration of the sum of Fifteen Thousand Dollars, (\$15,000.00), to be paid approved and adopted by the GOVERNING BODY OF THE CITY OF FAIRHOPE, ALABAMA, on the 22nd day of February, 2021; We, the Baldwin County Economic Development Alliance, Inc. ("BCEDA"), agree to work with the Mayor, and /or her agent(s) of the City of Fairhope to assist with economic development facilitation within the City of Fairhope. BCEDA is pleased to continue its 20-year relationship with the City of Fairhope. BCEDA's charge is to develop and facilitate new job creation opportunities for all communities in Baldwin County. BCEDA will work with City Leadership to continue to develop new job creation opportunities in but not limited to the following: IT, Software Development, Aerospace, Aviation and Medical sectors. We will continue to work with the Mayor, City Staff and City Council to identify, develop and promote designated areas of Fairhope for future job creation. BCEDA will continue to promote and market the City of Fairhope, advising national and international corporate decision makers of all that Fairhope has to offer them as a top site-selection location. BCEDA will continue to advise and assist the Mayor and City Leaders in developing a place and atmosphere in Fairhope that encourages, fosters, and facilitates entrepreneurship. BCEDA will work with local, regional and statewide workforce development partners to communicate current and future training and education requirements to Coastal Alabama Community College and The Academy at the Fairhope Airport.

The term of this contract is for one (1) year, beginning 1 October 2020 and ending 30 September 2021; but contract may be canceled at any time.

Pursuant of the motion for approval of this appropriation, payment is to be made quarterly in the amount of \$3,750.00 from the City of Fairhope until contract either expires or is cancelled.

Signed this 23rd day of February, 2021

BALDWIN COUNTY ECONOMIC  
DEVELOPMENT ALLIANCE, INC.

By \_\_\_\_\_  
Lee Lawson, President/CEO

CITY OF FAIRHOPE

By \_\_\_\_\_  
Sherry Sullivan, Mayor

Attest:

\_\_\_\_\_  
Lisa A. Hanks, MMC  
City Clerk

**RESOLUTION NO. \_\_\_\_\_**

**WHEREAS**, a contract shall be executed between the City of Fairhope and Care House, Inc., making an appropriation of \$5,000.00 to help with continuing support for children who are victims of sexual and severe physical abuse; and to help achieve normalcy through our counseling and advocacy program for children and families who come to us after being victimized. This appropriation will also help with the distribution of the child abuse prevention curriculum, "Keeping Our Kids Safe" and prevention presentation held throughout Baldwin County.

**WHEREAS**, the term of said contract shall be for one (1) year, beginning 1 October 2020 and ending 30 September 2021; but the contract shall be cancelled at any time upon notice.

**WHEREAS**, payment shall be made in the total amount of \$5,000.00 from the Utility Funds.

**BE IT RESOLVED BY THE GOVERNING BODY OF THE CITY OF FAIRHOPE, ALABAMA**, That Mayor Sherry Sullivan is hereby authorized to sign a contract between the City of Fairhope and Care House, Inc.

DULY ADOPTED THIS 22ND DAY OF FEBRUARY, 2021

\_\_\_\_\_  
Jack Burrell, Council President

Attest

\_\_\_\_\_  
Lisa A. Hanks, MMC  
City Clerk

**CONTRACT**

STATE OF ALABAMA        )  
                                      :  
COUNTY OF BALDWIN    )

For and in consideration of the sum of Five Thousand Dollars, (\$5,000.00), to be paid as per motion for approval of this appropriation, duly approved and adopted by the GOVERNING BODY OF THE CITY OF FAIRHOPE, ALABAMA, on the 22nd day of February, 2021; We, CARE HOUSE, INC., agree to work with the Mayor and/or her agent(s) of the City of Fairhope to help with continuing support for children who are victims of sexual and severe physical abuse; and to help achieve normalcy through our counseling and advocacy program for children and families who come to us after being victimized. This appropriation will also help with the distribution of the child abuse prevention curriculum, "Keeping Our Kids Safe" and prevention presentation held throughout Baldwin County.

The term of this contract shall be for the Fiscal year of 2020 - 2021. This contract may be cancelled at any time.

Pursuant of the motion for approval of this appropriation, a one-time payment shall be made in the total amount of \$5,000.00 from the Utility Funds, until contract either expires or is cancelled.

Signed this 23rd day of February, 2021

CARE HOUSE, INC.

By \_\_\_\_\_  
Niki Whitaker, Executive Director

CITY OF FAIRHOPE

By \_\_\_\_\_  
Sherry Sullivan, Mayor

Attest:

\_\_\_\_\_  
Lisa A. Hanks, MMC  
City Clerk



**RESOLUTION NO. \_\_\_\_**

**WHEREAS**, the Downtown Fairhope Business Association serves a public purpose and the publicity that the Downtown Fairhope Business Association gives the City of Fairhope is a public service; and,

**WHEREAS**, We, the Downtown Fairhope Business Association agree to work with the Mayor, and/or her agent(s); advertise regionally and promote the City of Fairhope.

**WHEREAS**, the term of said contract shall be for one (1) year, beginning 1 October 2020 and ending 30 September 2021; but the contract shall be cancelled at any time upon notice.

**WHEREAS**, payment shall be made in the total amount of \$20,000.00 from the City of Fairhope.

**BE IT RESOLVED BY THE GOVERNING BODY OF THE CITY OF FAIRHOPE, ALABAMA** that Mayor Sherry Sullivan is hereby authorized to sign a contract between the City of Fairhope and the Downtown Fairhope Business Association.

DULY ADOPTED THIS 22ND DAY OF FEBRUARY, 2021

\_\_\_\_\_  
Jack Burrell, Council President

Attest

\_\_\_\_\_  
Lisa A. Hanks, MMC  
City Clerk

## CONTRACT

STATE OF ALABAMA    )  
                                  :  
COUNTY OF BALDWIN    )

For and in consideration of the sum of Twenty Thousand Dollars (\$20,000.00), to be paid as per motion for approval of this appropriation, duly approved and adopted by the GOVERNING BODY OF THE CITY OF FAIRHOPE, ALABAMA, on the 22nd day of February, 2021; We, the DOWNTOWN FAIRHOPE BUSINESS ASSOCIATION, agree to work with the Mayor and/or her agent(s) of the City of Fairhope to advertise and promote the City of Fairhope.

The term of this contract shall be for the Fiscal year of 2020 – 2021. This contract may be cancelled at any time.

Pursuant of the motion of this appropriation, a one-time payment shall be made in the amount of \$20,000.00 from the City of Fairhope, until contract either expires or is cancelled.

Signed this 23rd day of February, 2021

DOWNTOWN FAIRHOPE BUSINESS ASSOCIATION

By: \_\_\_\_\_  
Alex Robinson, Executive Director

CITY OF FAIRHOPE, ALABAMA

By: \_\_\_\_\_  
Sherry Sullivan, Mayor

Attest:

\_\_\_\_\_  
Lisa A. Hanks, MMC  
City Clerk

**RESOLUTION NO. \_\_\_\_\_**

WHEREAS, a contract shall be executed between the City of Fairhope and the Eastern Shore Art Center for contract funding educational programs through the Academy and Community Outreach Program which provides art education and hands-on learning, on and off site, to all elements of our community: children, youth, adults, seniors, and special needs audiences, making an appropriation of \$20,000.00; and

WHEREAS, the Eastern Shore Art Center must continue First Friday Artwalk and all publicity as a community event; continue to provide summer art program for the Fairhope-Point Clear Rotary Youth Club (formerly known as the Boys and Girls Club); and provide low cost art classes for local youth and senior citizens; and

WHEREAS, the City of Fairhope approves the request from the Eastern Shore Art Center to use the streets (Section Street north of Magnolia to Oak Street and Oak Street to Bancroft and Equality) during their Outdoor Art Show, which is held during the annual Arts & Crafts Festival, to use the streets (Fairhope Avenue from Bancroft Avenue to Church Street and Section Street from De La Mare to Magnolia Avenue) for the annual Grand Festival of Art in October; and requesting closure of the streets at 5:00 p.m. on the Friday before the festival for set-up; and security to be provided, after hours, by the Fairhope Police Department; and

WHEREAS, the term of said contract shall be for one (1) year, beginning 1 October 2020 and ending 30 September 2021; but the contract shall be cancelled at any time upon notice; and

WHEREAS, payment shall be made quarterly in the amount of \$5,000.00; until contract either expires or is cancelled.

BE IT RESOLVED BY THE GOVERNING BODY OF THE CITY OF FAIRHOPE, ALABAMA, THAT Mayor Sherry Sullivan is hereby authorized to sign a contract between the City of Fairhope and the Eastern Shore Art Center for funds to support and sponsor the educational programs through the Art Center's Academy for Fine Arts.

DULY ADOPTED THIS 22ND DAY OF FEBRUARY, 2021

\_\_\_\_\_  
Jack Burrell, Council President

Attest

\_\_\_\_\_  
Lisa A. Hanks, MMC  
City Clerk

# CONTRACT

STATE OF ALABAMA        )  
  :  
COUNTY OF BALDWIN     )

For and in consideration of the sum of Twenty Thousand Dollars, (\$20,000.00), to be paid as per motion for approval of this appropriation, duly approved and adopted by the GOVERNING BODY OF THE CITY OF FAIRHOPE, ALABAMA, on the 22nd day of February, 2021; We, the EASTERN SHORE ART CENTER, agree to work with the Mayor and/or her agent(s) of the City of Fairhope on the Academy and Community Outreach Program which provides art education and hands-on learning, and off site, to all elements of our community: children, youth, adults, seniors, and special needs audiences.

The Eastern Shore Art Center must continue First Friday Artwalk and all publicity as a community event; continue to provide summer art program for the Fairhope-Point Clear Rotary Youth Club (formerly known as the Boys and Girls Club); and provide low cost art classes for local youth and senior citizens.

The City of Fairhope approves the request from the Eastern Shore Art Center to use the streets (Section Street north of Magnolia to Oak Street and Oak Street to Bancroft and Equality) during their Outdoor Art Show, which is held during the annual Arts & Crafts Festival; to use the streets (Fairhope Avenue from Bancroft Avenue to Church Street and Section Street from De La Mare to Magnolia Avenue) for the annual Grand Festival of Art in October; and requesting closure of the streets at 5:00 p.m. on the Friday before the festival for set-up; and security to be provided, after hours, by the Fairhope Police Department.

The term of this contract shall be for the Fiscal year of 2020 - 2021. This contract may be cancelled at any time.

Pursuant of the motion for approval of this appropriation, payment is to be made quarterly in the amount of \$5,000.00 from the City of Fairhope; until contract either expires or is cancelled.

Signed this 23rd day of February, 2021

EASTERN SHORE ART CENTER

By \_\_\_\_\_  
Bryant Whelan

CITY OF FAIRHOPE

By \_\_\_\_\_  
Sherry Sullivan, Mayor

Attest:

\_\_\_\_\_  
Lisa A. Hanks, MMC  
City Clerk

**RESOLUTION NO. \_\_\_\_\_**

**WHEREAS**, the Eastern Shore Chamber of Commerce serves a public purpose and the publicity that the Eastern Shore Chamber of Commerce gives the City of Fairhope is a public service; and,

**WHEREAS**, We, the Eastern Shore Chamber of Commerce, agree to work with the Mayor, and/or his agent(s), advertise (regionally and nationally) and promote the City of Fairhope and to enhance City revenues through economic development including sales & use taxes, lodging taxes, business licenses, etc.; and to promote public arts and crafts for residents and visitors through the annual arts and crafts festival.

**BE IT RESOLVED BY THE GOVERNING BODY OF THE CITY OF FAIRHOPE, ALABAMA**, that the Mayor Karin Wilson is hereby authorized to enter into a contract with the Eastern Shore Chamber of Commerce to promote the City of Fairhope. The contract shall be for one year, beginning 1 October 2020 and ending 30 September 2021; but may be canceled at any time. The contract shall call for a one-time payment to the Eastern Shore Chamber of Commerce in the total amount of \$21,000.00 (which includes \$15,000.00 for the Annual Leaders Council Program) from the City of Fairhope, for the one-year term.

Adopted this 22nd day of February, 2021

\_\_\_\_\_  
Jack Burrell, Council President

ATTEST:

\_\_\_\_\_  
Lisa A. Hanks, MMC  
City Clerk

# CONTRACT

STATE OF ALABAMA        )  
  :  
COUNTY OF BALDWIN     )

For and in consideration of the sum of Twenty-One Thousand Dollars, (\$21,000.00 which includes \$15,000.00 for the Annual Leaders Council Program), to be paid as per resolution for approval of this appropriation, duly approved and adopted by the GOVERNING BODY OF THE CITY OF FAIRHOPE, ALABAMA, on the 22nd day of February, 2021; We, the EASTERN SHORE CHAMBER OF COMMERCE, agree to work with the Mayor, and /or her agent(s), to advertise and promote the City of Fairhope and to enhance City revenues through economic development including sales & use taxes, lodging taxes, business licenses, etc.; and to promote public arts and crafts for residents and visitors through the annual arts and crafts festival.; and

The term of this contract is for one (1) year, beginning 1 October 2020 and ending 30 September 2021; but contract may be cancelled at any time.

Pursuant to resolution for approval of this appropriation and request for usage of the City facilities; and resources described above, a one-time payment shall be made in the total amount of \$21,000.00 (which includes \$15,000.00 for the Annual Leaders Council Program) from the City of Fairhope, until contract either expires or is cancelled.

Signed this 23rd day of February, 2021

EASTERN SHORE CHAMBER OF COMMERCE

By \_\_\_\_\_  
Casey Gay Williams, President

CITY OF FAIRHOPE

By \_\_\_\_\_  
Sherry Sullivan, Mayor

Attest:

\_\_\_\_\_  
Lisa A. Hanks, MMC  
City Clerk

**RESOLUTION NO. \_\_\_\_\_**

**WHEREAS**, contract shall be executed between the City of Fairhope and the Baldwin Pops, making an appropriation of \$2,000.00, in-kind services, and resources including personnel, but not security after normal business hours; and provides an exception to the Sign Ordinance by allowing banners for their Citywide events and to be displayed 10 days prior those events to advertise and promote the City of Fairhope; and to provide free concerts yearly for the residents of Fairhope, also performs at the City's July 4th celebration and the Founder's Day Concert and when available participates in the Veteran Day parade.

**WHEREAS**, the following is the breakdown of the four concerts and total in-kind services in the amount of \$8,400.00:

The following is the breakdown of the four concerts [total in-kind services \$8,400.00]:

July Concert, Bluff	October Concert, Bluff
- <b>\$2000</b> Concert fee	- <b>\$200</b> Facility rental fees (in-kinds services)
- <b>\$200</b> Facility rental fees (in-kind services)	- <b>\$4000</b> [staging, sound, portables]
- <b>\$4000</b> [staging, sound, portables]	<b>Total: \$4200.00</b>
<b>Total: \$6200.00</b>	

**WHEREAS**, the term of said contract shall be for one (1) year, beginning 1 October 2020 and ending 30 September 2021; but the contract shall be cancelled at any time upon notice.

**WHEREAS**, payment shall be made in the amount of \$2,000.00 from the City of Fairhope.

**BE IT RESOLVED BY THE GOVERNING BODY OF THE CITY OF FAIRHOPE, ALABAMA**, That Mayor Sherry Sullivan is hereby authorized to sign a contract between the City of Fairhope and the Baldwin Pops.

ADOPTED this 22nd day of February, 2021

\_\_\_\_\_  
Jack Burrell, Council President

ATTEST:

\_\_\_\_\_  
Lisa A. Hanks, MMC  
City Clerk

**CONTRACT**

STATE OF ALABAMA )  
 :  
COUNTY OF BALDWIN )(

For and in consideration of the sum of Six Thousand Dollars, (\$2,000.00) and use of the Bluff for three concerts and the Civic Center for one concert, to be paid as per motion for approval of this appropriation, ); resources including personnel, but not security after normal business hours; and provides an exception to the Sign Ordinance by allowing banners for their Citywide events and to be displayed 10 days prior those events, duly approved and adopted by the GOVERNING BODY OF THE CITY OF FAIRHOPE, ALABAMA, on the 22nd day of February, 2021; We, the BALDWIN POPS, agree to work with the Mayor, and /or his agent(s), to advertise and promote the City of Fairhope; and to provide free concerts yearly for the residents of Fairhope, also performs at the City’s July 4th celebration and the Founder’s Day Concert and when available participates in the Veteran Day parade.

The following is the breakdown of the four concerts [total in-kind services \$8,400.00]:

- |  |  |
|--|--|
| July Concert, Bluff                                    | October Concert, Bluff                                 |
| - <b>\$2000</b> Concert fee                            | - <b>\$200</b> Facility rental fees (in-kind services) |
| - <b>\$200</b> Facility rental fees (in-kind services) | - <b>\$4000</b> [staging, sound, portables]            |
| - <b>\$4000</b> [staging, sound, portables]            | <b>Total: \$4200.00</b>                                |
| <b>Total: \$6200.00</b>                                |  |

The term of this contract shall be for the Fiscal year of 2020 - 2021. This contract may be cancelled at any time. Pursuant of the motion for approval of this appropriation, a one-time payment shall be made in the amount of \$2,000.00, until contract either expires or is cancelled.

Signed this 22nd day of February, 2021

BALDWIN POPS

By \_\_\_\_\_  
Anne Brooks

CITY OF FAIRHOPE

By \_\_\_\_\_  
Sherry Sullivan, Mayor

Attest:

\_\_\_\_\_  
Lisa A. Hanks, MMC  
City Clerk



## RESOLUTION NO. \_\_\_\_\_

WHEREAS, in Fairhope, Alabama, Ecumenical Ministries Incorporated (EMI) is a public, non-profit, non-denominational, United Way social service agency; and,

WHEREAS, EMI's mission is to improve the quality of life in Baldwin County by meeting basic needs, encouraging personal growth, effecting social and economic justice and celebrate our common life; and,

WHEREAS, EMI provide services to the socio-economic and those in crisis situations and have no place to turn for help on the Eastern Shore, including Fairhope and South Baldwin County. The services rendered include:

- Emergency Aid – Direct assistance for medical, food, utilities, rent, clothing, child care, transportation and other emergency needs.
- Meals on Wheels (MOW'S) – Volunteer's deliver nutritious, warm meals six days a week. Meals are subsidized based on need and funding – Fairhope area has nine routes.
- Home Repair – These projects include plumbing, electrical work, rebuilding floors, installing windows and doors, roofing, building wheelchair ramps and more. This program is for the elderly and disabled.
- Food Pantry – Our pantries provide a week's supply of food based on the size of the family and their situation.
- Prescription Assistance – This program allows under-insured and non-insured persons to receive life sustaining medications at reduced or no cost through pharmaceutical companies' indigent care program. EMI also provide prescription assistance through the Ozanam Charitable Pharmacy in Mobile.
- Church-based Community Organizing – This program empowers poor and moderate income families to participate effectively in our democratic system and allow community members the opportunity to address the issues affecting their lives: paved streets, lighting, sewage, recreation and drainage.
- EMMY'S Thrift Shop – Through our emergency aid center vouchers are given at no cost. With these vouchers, people can receive such items as appliances, furniture, clothing, etc.

Resolution No. \_\_\_\_\_  
Page -2-

WHEREAS, Ecumenical Ministries Incorporated has served Fairhope residents since 1969 on a continuous basis and successfully demonstrated the capacity to operate a neighborhood based on social service agency improving countless lives.

BE IT RESOLVED BY THE GOVERNING BODY OF THE CITY OF FAIRHOPE, FAIRHOPE, ALABAMA, that Mayor Karin Wilson is hereby authorized to establish a contract for services between the City of Fairhope and Ecumenical Ministries Incorporated to appropriate the sum of \$10,000.00 to be used for the needs of Fairhope residents.

DULY ADOPTED THIS THE 22ND DAY OF FEBRUARY, 2021

\_\_\_\_\_  
Jack Burrell, Council President

ATTEST:

\_\_\_\_\_  
Lisa A. Hanks, MMC  
City Clerk

# CONTRACT

STATE OF ALABAMA    )  
                                  :  
COUNTY OF BALDWIN    )

For and in consideration of the sum of Ten Thousand Dollars, (\$10,000.00), to be paid as per motion for approval of this appropriation, duly approved and adopted by the GOVERNING BODY OF THE CITY OF FAIRHOPE, ALABAMA, on the 22nd day of February, 2021; We, ECUMENICAL MINISTRIES INCORPORATED of Fairhope, agree to work with the Mayor and/or her agent(s) of the City of Fairhope to continue helping with the operation of our ministry and its mission to help families in need in the City of Fairhope.

The term of this contract is for one (1) year, beginning 1 October 2020 and ending 30 September 2021; but contract may be cancelled at any time.

Pursuant of the motion of this appropriation, a one-time payment shall be made in the amount of \$10,000.00 from the City of Fairhope, until contract either expires or is cancelled.

Signed this 23rd day of February, 2021

ECUMENICAL MINISTRIES INCORPORATED

By \_\_\_\_\_  
Sally Deane, Executive Director

CITY OF FAIRHOPE

By \_\_\_\_\_  
Sherry Sullivan, Mayor

Attest:

\_\_\_\_\_  
Lisa A. Hanks, MMC  
City Clerk

**RESOLUTION NO. \_\_\_\_\_**

WHEREAS, a contract shall be executed between the City of Fairhope and the Fairhope Film Festival, making an appropriation of \$6,000.00, to help bring sustained economic growth from the film industry to the Alabama Gulf Coast through its Fairhope Film Festival.

WHEREAS, the term of said contract shall be for one (1) year, beginning 1 October 2020 and ending 30 September 2021; but the contract shall be cancelled at any time upon notice.

WHEREAS, payment shall be made in the total amount of \$6,000.00 from the City of Fairhope.

BE IT RESOLVED BY THE GOVERNING BODY OF THE CITY OF FAIRHOPE, ALABAMA, THAT Mayor Sherry Sullivan is hereby authorized to sign a contract between the City of Fairhope and the Fairhope Film Festival.

DULY ADOPTED THIS 22ND DAY OF FEBRUARY, 2021

\_\_\_\_\_  
Jack Burrell, Council President

Attest

\_\_\_\_\_  
Lisa A. Hanks, MMC  
City Clerk

# CONTRACT

STATE OF ALABAMA    )  
  :  
COUNTY OF BALDWIN    )

For and in consideration of the sum of Six Thousand Dollars, (\$6,000.00), to be paid as per motion for approval of this appropriation, duly approved and adopted by the GOVERNING BODY OF THE CITY OF FAIRHOPE, ALABAMA, on the 22nd day of February, 2021; We, THE FAIRHOPE FILM FESTIVAL, agree to work with the Mayor and/or her agent(s) of the City of Fairhope to help bring sustained economic growth from the film industry to the Alabama Gulf Coast through its Fairhope Film Festival.

The term of this contract shall be for the Fiscal year of 2020 - 2021. This contract may be cancelled at any time.

Pursuant of the motion of this appropriation, a one-time payment shall be made in the amount of \$6,000.00 from the City of Fairhope, until contract either expires or is cancelled.

Signed this 23rd day of February, 2021

THE FAIRHOPE FILM FESTIVAL

By \_\_\_\_\_  
Mary Riser, Executive Director

CITY OF FAIRHOPE

By \_\_\_\_\_  
Karin Wilson, Mayor

Attest:

\_\_\_\_\_  
Lisa A. Hanks, MMC  
City Clerk

**RESOLUTION NO. \_\_\_\_**

WHEREAS, a contract shall be executed between the City of Fairhope and the Mobile Bay National Estuary Program, making an appropriation of \$15,000.00 to support expanded activities related to Stormwater education and watershed management. The Mobile Bay National Estuary Program recently partnered with the City of Fairhope for the Volanta Gulley Watershed Management Plan and projects at the Fairhope ball fields, Dog Park, and Jasmine Park.

WHEREAS, the term of said contract shall be for one (1) year, beginning 1 October 2020 and ending 30 September 2021; but the contract shall be cancelled at any time upon notice.

WHEREAS, payment shall be made quarterly in the amount of \$3,750.00, until contract either expires or is cancelled.

BE IT RESOLVED BY THE GOVERNING BODY OF THE CITY OF FAIRHOPE, ALABAMA, THAT Mayor Sherry Sullivan is hereby authorized to sign a contract between the City of Fairhope and the Mobile Bay National Estuary Program.

DULY ADOPTED THIS 22ND DAY OF FEBRUARY, 2021

\_\_\_\_\_  
Jack Burrell, Council President

Attest

\_\_\_\_\_  
Lisa A. Hanks, MMC  
City Clerk

# CONTRACT

STATE OF ALABAMA        )  
                                  :  
COUNTY OF BALDWIN     )

For and in consideration of the sum of Fifteen Thousand Dollars, (\$15,000.00), to be paid as per motion for approval of this appropriation, duly approved and adopted by the GOVERNING BODY OF THE CITY OF FAIRHOPE, ALABAMA, on the 22nd day of February, 2021; We, MOBILE BAY NATIONAL ESTUARY PROGRAM, agree to work with the Mayor and/or her agent(s) of the City of Fairhope to support expanded activities related to Stormwater education and watershed management. The Mobile Bay National Estuary Program recently partnered with the City of Fairhope for the Volanta Gulley Watershed Management Plan; and projects at the Fairhope ball fields, Dog Park, and Jasmine Park.

The term of this contract shall be for the Fiscal year of 2020 – 2021. This contract may be cancelled at any time.

Pursuant of the motion for approval of this appropriation, payment is to be made quarterly in the amount of \$3,750.00 from the City of Fairhope; until contract either expires or is cancelled.

Signed this 23rd day of February, 2021

MOBILE BAY NATIONAL ESTUARY PROGRAM

By \_\_\_\_\_  
Roberta A. Swann, Director

CITY OF FAIRHOPE

By \_\_\_\_\_  
Sherry Sullivan, Mayor

Attest:

\_\_\_\_\_  
Lisa A. Hanks, MMC  
City Clerk

**RESOLUTION NO. \_\_\_\_\_**

WHEREAS, a contract shall be executed between the City of Fairhope and the Fairhope Pirate Booster Club, Inc., making an appropriation of \$10,000.00 to be used to assist in the purchase of three Clorox Total360 disinfectant sprayers to be placed in the Girl's Fieldhouse, Men's Fieldhouse, and locker rooms to disinfect the site and equipment. These units will benefit all sports in both men's and women's athletic programs to help provide the safest and cleanest environment possible. This also includes the use of the Fairhope Civic Center for the Annual Drawdown and Silent Auction (date to be announced) which includes the use of associated rooms as needed, placement of a tent in the parking lot (all rental expenses paid by the Club), and use of the facility's tables and chairs in the tent.

WHEREAS, the term of said contract shall be for one (1) year, beginning 1 October 2020 and ending 30 September 2021; but the contract shall be cancelled at any time upon notice.

WHEREAS, payment shall be made quarterly in the amount of \$2,500.00, until contract either expires or is cancelled.

BE IT RESOLVED BY THE GOVERNING BODY OF THE CITY OF FAIRHOPE, ALABAMA, THAT Mayor Sherry Sullivan is hereby authorized to sign a contract between the City of Fairhope and the Fairhope Pirate Booster Club, Inc.

DULY ADOPTED THIS 22ND DAY OF FEBRUARY, 2021

\_\_\_\_\_  
Jack Burrell, Council President

Attest

\_\_\_\_\_  
Lisa A. Hanks, MMC  
City Clerk



# CONTRACT

STATE OF ALABAMA        )  
                                  :  
COUNTY OF BALDWIN     )(

For and in consideration of the sum of Ten Thousand Dollars, (\$10,000.00), to be paid as per motion for approval of this appropriation, duly approved and adopted by the GOVERNING BODY OF THE CITY OF FAIRHOPE, ALABAMA, on the 22nd day of February, 2021; We, THE FAIRHOPE PIRATE BOOSTER CLUB, INC., agree to work with the Mayor and/or her agent(s) of the City of Fairhope to assist in the purchase of three Clorox Total360 disinfectant sprayers to be placed in the Girl's Fieldhouse, Men's Fieldhouse, and locker rooms to disinfect the site and equipment. These units will benefit all sports in both men's and women's athletic programs to help provide the safest and cleanest environment possible. This also includes the use of the Fairhope Civic Center for the Annual Drawdown and Silent Auction (date to be announced) which includes the use of associated rooms as needed, placement of a tent in the parking lot (all rental expenses paid by the Club), and use of the facility's tables and chairs in the tent.

The term of this contract shall be for the Fiscal year of 2020 - 2021. This contract may be cancelled at any time.

Pursuant of the motion for approval of this appropriation, payment is to be made quarterly in the amount of \$2,500.00 from the City of Fairhope until contract either expires or is cancelled.

Signed this 23rd day of February, 2021

FAIRHOPE PIRATE BOOSTER CLUB, INC.

By \_\_\_\_\_  
Steven E. Cortinas, President

CITY OF FAIRHOPE

By \_\_\_\_\_  
Sherry Sullivan, Mayor

Attest:

\_\_\_\_\_  
Lisa A. Hanks, MMC  
City Clerk

# FAIRHOPE PIRATE BOOSTER CLUB



June 15, 2020

City of Fairhope  
P.O. Drawer 429  
Fairhope, AL 36533

To the Honorable City Council,

The Fairhope Pirate Booster Club, Inc. is a 501(3c) non-profit corporation as defined by the Internal Revenue Service. We are operated as an "all volunteer" organization and funded through membership, donations, and special event fundraisers. Our mission is to provide financial support to Fairhope High School and Middle School athletics primarily for the purposes of capital projects and play-off travel expenses. As a practical matter, we also contribute to the school for other unplanned expenses as they come before the Club membership.

On behalf of the Fairhope Pirate Booster Club, I would like to make the following requests for fee waivers and financial contributions for the upcoming year:

- 1. Financial contribution of \$11,000.00 for the purchase of three (3) Clorox Total360 disinfectant sprayers (see attached). These units will be placed in the Girls Fieldhouse, Men's fieldhouse, and locker rooms to disinfect the site and training equipment including mats for cheer and wrestling, weight training equipment, showers and lockers rooms. Even during normal times the risk of infection to students athletes is a concern, but in light of the COVID 19 crisis it is needed now more than ever. These units will benefit all sports in both men's and women's athletic programs to help provide the safest, cleanest environment possible.**

**The Club will further request the use of the Fairhope Civic Center for the 26<sup>th</sup> Annual Drawdown and Silent Auction (date to be announced). This request is for use of the Civic Center including associated rooms as needed, placement of a tent in the parking lot (all rental expenses paid by the club), and use of the facility's table and chairs in the tent.**

We thank you very much for your consideration of these requests. Please do not hesitate to call or email if you have any questions or if I may be any assistance.

Sincerely,

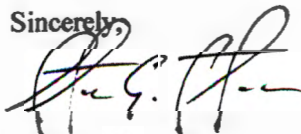

Steven E Cortinas  
President  
Fairhope Pirate Booster Club  
P.O. Box 84  
Fairhope, AL 36533

**RESOLUTION NO. \_\_\_\_\_**

**WHEREAS**, the Fairhope-Point Clear Rotary Youth Club serves a public purpose and the programs and activities that the Fairhope-Point Clear Rotary Youth Club gives the City of Fairhope are a public service; and,

**WHEREAS**, the Fairhope-Point Clear Rotary Youth Club, agrees to work with the Mayor, and/or her agent(s), to better meet the needs of our community's youth through programs and activities; i.e. quality after school and summer programs which is an absolute necessity for our community.

**WHEREAS**, the term of said contract shall be for one (1) year, beginning 1 October 2020 and ending 30 September 2021; but the contract shall be cancelled at any time upon notice.

**WHEREAS**, payment shall be made quarterly in the amount of \$14,250.00 from the City of Fairhope; until contract either expires or is cancelled.

**BE IT RESOLVED BY THE GOVERNING BODY OF THE CITY OF FAIRHOPE, ALABAMA**, that Mayor Sherry Sullivan is hereby authorized to execute contract between the City of Fairhope and the Fairhope-Point Clear Rotary Youth Club to support the programs and activities to better serve our community and its youth by helping to manage and operate the Fairhope-Point Clear Rotary Youth Club facility and for facility maintenance which includes cleaning supplies.

ADOPTED THIS 22ND DAY OF FEBRUARY, 2021

\_\_\_\_\_  
Jack Burrell, Council President

ATTEST:

\_\_\_\_\_  
Lisa A. Hanks, MMC  
City Clerk

**CONTRACT**

STATE OF ALABAMA        )  
  :  
COUNTY OF BALDWIN     )

For and in consideration of the sum of Fifty-Seven Thousand Dollars, (\$57,000.00), to be paid as per resolution for approval of this appropriation, duly approved and adopted by the GOVERNING BODY OF THE CITY OF FAIRHOPE, ALABAMA, on the 22nd day of February, 2021; We, the FAIRHOPE-POINT CLEAR ROTARY YOUTH CLUB, agree to work with the Mayor, and /or her agent(s), to better meet the needs of our community's youth through programs and activities; i.e. quality after school and summer programs which is an absolute necessity for our community by helping to manage and operate the Fairhope-Point Clear Rotary Youth Club Facility and for facility maintenance which includes cleaning supplies.

The term of this contract is for one (1) year, beginning 1 October 2020 and ending 30 September 2021; but contract may be cancelled at any time.

Pursuant of the motion for approval of this appropriation, payment is to be made quarterly in the amount of \$14,250.00 from the City of Fairhope; until contract either expires or is cancelled.

Signed this 23rd day of February, 2021

FAIRHOPE-POINT CLEAR ROTARY YOUTH CLUB

By \_\_\_\_\_  
Tracey Miller, Executive Director

CITY OF FAIRHOPE

By \_\_\_\_\_  
Sherry Sullivan, Mayor

Attest:

\_\_\_\_\_  
Lisa A. Harks, MMC  
City Clerk

**RESOLUTION NO. \_\_\_\_\_**

**WHEREAS**, a contract shall be executed between the City of Fairhope and Fairhope Educational Enrichment Foundation, Inc. (“FEEF”), making an appropriation of \$50,000.00 to help with the FEEF STEAM Center to be located at the K-1 Center.

**WHEREAS**, the term of said contract shall be for one (1) year, beginning 1 October 2020 and ending 30 September 2021; but the contract shall be cancelled at any time upon notice.

**WHEREAS**, payment shall be made quarterly in the amount of \$12,500.00 from the City of Fairhope.

**BE IT RESOLVED BY THE GOVERNING BODY OF THE CITY OF FAIRHOPE, ALABAMA**, That Mayor Sherry Sullivan is hereby authorized to sign a contract between the City of Fairhope and Fairhope Educational Enrichment Foundation, Inc.

DULY ADOPTED THIS 22ND DAY OF FEBRUARY, 2021

\_\_\_\_\_  
Jack Burrell, Council President

Attest

\_\_\_\_\_  
Lisa A. Hanks, MMC  
City Clerk

**CONTRACT**

STATE OF ALABAMA     )  
  :  
COUNTY OF BALDWIN    )

For and in consideration of the sum of Fifty Thousand Dollars, (\$50,000.00), to be paid as per motion for approval of this appropriation, duly approved and adopted by the GOVERNING BODY OF THE CITY OF FAIRHOPE, ALABAMA, on the 22nd day of February, 2021; We, FAIRHOPE EDUCATIONAL ENRICHMENT FOUNDATION, INC., agree to work with the Mayor and/or her agent(s) of the City of Fairhope to help with the FEEF STEAM Center to be located at the K-1 Center.

The term of this contract shall be for the Fiscal year of 2020 - 2021. This contract may be cancelled at any time.

Pursuant of the motion for approval of this appropriation, payment is to be made quarterly in the amount of \$12,500.00 from the City of Fairhope, until contract either expires or is cancelled.

Signed this 23rd day of February, 2021

FAIRHOPE EDUCATIONAL  
ENRICHMENT FOUNDATION, INC.

By \_\_\_\_\_  
Paula White, Director of Operations

CITY OF FAIRHOPE

By \_\_\_\_\_  
Sherry Sullivan, Mayor

Attest:

\_\_\_\_\_  
Lisa A. Hanks, MMC  
City Clerk

**RESOLUTION NO. \_\_\_\_**

**BE IT RESOLVED BY THE GOVERNING BODY OF THE CITY OF FAIRHOPE, ALABAMA**, as follows:

[1] That the City of Fairhope did request, receive, and open bids for Municipal Pier Utility Tray Repairs Rebid damaged by Hurricane Zeta for the Public Works Department (Bid Number 012-21) at 555 South Section Street in the City of Fairhope offices, Fairhope, Alabama.

The initial RFQ was sent to twenty-seven (27) contractors as well as multiple State agencies for MBE and DEB consideration and received no quotes.

[2] At the appointed time and place, the bids were opened and tabulated.

[3] After evaluating the bid proposals with the required bid specifications, one Bid was received, we request that all bids be rejected for Bid No. 012-21 Municipal Pier Utility Tray Repairs Rebid for the Public Works Department pursuant to the Code of Alabama 1975, Section 41-16-57-2(d); and reevaluate project scope.

Adopted on this 22nd day of February, 2021

---

Jack Burrell, Council President

Attest:

---

Lisa A. Hanks, MMC  
City Clerk



## MEMO

449-1873, 14, 19  
ZAM

To: Kimberly Creech, Treasurer

From: Delores A Brandt  
Delores A. Brandt, Purchasing Manager

Date: February 10, 2021

Sherry Sullivan  
Mayor

Re: **Greensheet/City Council request to reject all bids for Bid 012-21 Municipal Pier Utility Tray Repairs RE-BID damaged by Hurricane Zeta**

*Council Members:*  
Kevin G. Boone  
Robert A. Brown  
Jack Burrell, ACOMO  
Jimmy Conyers  
Corey Martin

The Public Works Director, Richard Johnson has need to repair the utility tray damaged at the Municipal Pier as a result of Hurricane Zeta.

Lisa A. Hanks, MMC  
City Clerk

Bid 009-21 Municipal Pier Utility Tray Repairs was issued to twenty-seven (27) contractors as well as multiple state agencies for MBE and DBE consideration. The City did not receive any quotes. The bid was reissued under Bid Number 012-21, and one bid was submitted. The Director of Public Works recommends the bid be rejected citing the following in Section 41-16-57 of the Code of Alabama 1975:

Kimberly Creech  
City Treasurer

*2(d) The awarding authority or requisitioning agency may reject any bid if the price is deemed excessive or quality of product inferior.*

**Please prepare a greensheet and place on the next City Council Agenda this request to reject all bids for Bid 012-21 Municipal Pier Utility Tray Repairs RE-BID.**

Cc: File, R. Johnson

161 North Section St.  
PO Drawer 429  
Fairhope, AL 36533

251-928-2136 (p)  
251-928-6776 (f)  
www.fairhopeal.gov



**City of Fairhope Tabulation**  
**BID 012-21 Municipal Pier Utility Tray Repairs - RE-BID**  
**Bid Opening: Tuesday, December 29, 2020, 10:00 a.m.**

	Executed Bid Documents	LUMP SUM PRICE
Mitchell Contracting		no bid
John G. Walton		no bid
EJ Builders		no bid
ASI		no bid
McElhenney Construction		no bid
SC Stagner		no bid
Cunningham Delaney		no bid
A Long Boring		no bid
Ammons & Blackmon		no bid
Baldwin Road Builders		no bid
Kelley's Welding and Excavating		no bid
Thomas Electric		no bid
Sycamore, Inc.		no bid
L. Scott Construction, Inc.		no bid
Janice Rosser		no bid
Gaddy Electric, Plumbing, Heating & Cooling		no bid
H&H Electric		no bid
EM Global South		no bid
Southern Electric Corp of MS		no bid
Port City Pipe		no bid
Dodd Electric		no bid
Chancellor, Inc.		no bid
MDS Construction		no bid
Arrington, Inc.		no bid
<b>Harris Contracting Services</b>	yes	\$ 238,107.00
Bill Smith Electric		no bid
Stewart Engineering		no bid

**RECOMMENDATION: Reject all bids and reevaluate project scope.**

*To the best of my knowledge this is an accurate bid tabulation.*

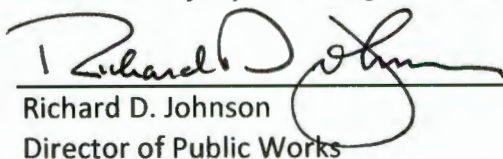
 02 / 10 / 2021  
 Richard D. Johnson Date  
 Director of Public Works

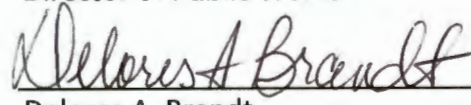
 2 / 10 / 2021  
 Delores A. Brandt Date  
 Purchasing Manager

**RESOLUTION NO. \_\_\_\_\_**

**BE IT RESOLVED BY THE GOVERNING BODY OF THE CITY OF FAIRHOPE, ALABAMA,** that Mayor Sherry Sullivan is hereby authorized to execute a contract for Extension No. 1 of Bid No. 016-20, Sludge Removal Services 2020 for the Sewer Department, with GreenSouth Solutions, LLC for an additional one year, as per the terms and conditions of the original contract. The total bid proposal of \$85.00 per cubic yard, for an estimated annual cost of \$550,000.00.

Adopted on this 22nd day of February, 2021

\_\_\_\_\_  
Jack Burrell, Council President

Attest:

\_\_\_\_\_  
Lisa A. Hanks, MMC  
City Clerk

City of Fairhope  
Project Funding Request

Issuing Date: 2/10/2021

Please return this Routing Sheet to Treasurer by: ASAP

FEB 10 '21 PM 5:29  
*ZAH*

Project Name: Approve Extension 1 of Bid 016-20 Sludge Removal Services 2020

Project Location: Sewer Plant

Presented to City Council: 2/22/2021

Funding Request Sponsor: Jason Langley, Water & Sewer Superintendent

Resolution # :  
Approved \_\_\_\_\_  
Changed \_\_\_\_\_  
Rejected \_\_\_\_\_

Project Cash Requirement Requested:  
Cost: \$ 550,000.00 Estimated cost based on contract pricing and FY2020 frequency of service \$85/cubic yard

Vendor: GreenSouth Solutions, LLC

Project Engineer: n/a

Order Date: n/a Lead Time: n/a

**Department Funding This Project**

General  Gas  Electric  Water  **Sewer**  Gas Tax  Cap Project  Impact  Health  Fed Grant

**Department of General Fund Providing the Funding**

Admin-10  Bldg-13  Police-15  Fire-20  ECD-24  Rec-25  Civic-26  Street-35  Sanitation-40   
 Fac Maint-45  Golf-50  Golf Grounds-55  Museum-70  Debt Service-85  Marina-34  Plan/Zone

Project will be:

Expensed XXX   
 Capitalized \_\_\_\_\_   
 Inventoried \_\_\_\_\_

Funding Source:

Operating Expenses XXX   
 Budgeted Capital \_\_\_\_\_   
 Unfunded \_\_\_\_\_

Expense Code: 004020-50405  
 G/L Acct Name: Sludge Removal

Project Budgeted: \$ 550,000.00  
 Balance Sheet Item-  
 Included in projected  
 cash flow \_\_\_\_\_

Over (Under) budget amount: \$ -

Comments:

Grant: \_\_\_\_\_ Federal - not to exceed amount  
 \_\_\_\_\_ State  
 \_\_\_\_\_ City  
\$0.00 Local

Bond: \_\_\_\_\_ Title \_\_\_\_\_ Year \_\_\_\_\_  
 Loan: \_\_\_\_\_ Title \_\_\_\_\_ Year \_\_\_\_\_

Capital Lease: \_\_\_\_\_ - Payment \_\_\_\_\_ Term \_\_\_\_\_

City Council Prior Approval/Date? \_\_\_\_\_

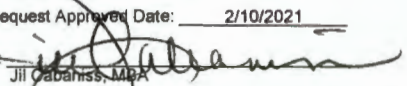
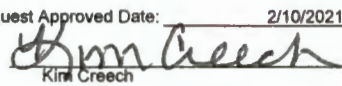
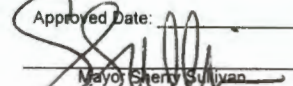
<b>Finance Manager</b>	<b>City Treasurer</b>	<b>Mayor</b>
Purchasing Memo Date: <u>2/9/2021</u>	Purchasing Memo Date: <u>2/9/2021</u>	Delivered To Date: <u>2/10/2021</u>
Request Approved Date: <u>2/10/2021</u>	Request Approved Date: <u>2/10/2021</u>	Approved Date: _____
Signatures:  Jill Cabaniss, MBA	 Kim Creech	 Mayor Sherry Sullivan



## MEMO

Sherry Sullivan  
Mayor

*Council Members:*  
Kevin G. Boone  
Robert A. Brown  
Jack Burrell, ACOMO  
Jimmy Conyers  
Corey Martin

Lisa A. Hanks, MMC  
City Clerk

Kimberly Creech  
City Treasurer

To: Kimberly Creech, Treasurer

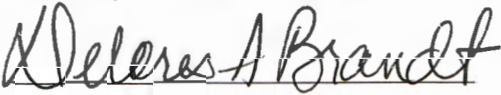
From:   
Delores A. Brandt, Purchasing Manager

Date: February 9, 2021

Re: Request City Council to approve **Extension 1 of Bid 016-20 Sludge Removal Services 2020**

The Contract for the subject bid was executed on March 10, 2020 and awarded to **GreenSouth Solutions, LLC**. The Contract will terminate on March 10, 2021. The Water and Wastewater Superintendent, Jason Langley, requests the City exercise the option of extending the bid one additional year to March 9, 2022.

The Vendor has agreed to Extension 1, with all terms and conditions of the bid award, including pricing, remaining the same (see attached letter).

**Please place on the next City Council agenda this request to approve Extension 1 of the contract for Bid 016-20 Sludge Removal Services 2020 to GreenSouth Solutions, LLC calculated at \$85.00 per cubic yard in the original contract.**

Cc: File, Jason Langley

161 North Section St.  
PO Drawer 429  
Fairhope, AL 36533

251-928-2136 (p)  
251-928-6776 (f)  
[www.fairhopeal.gov](http://www.fairhopeal.gov)



**GREENSOUTH**  
solutions

*PO Box 325, Florala, Alabama 36442*  
*334-858-2622*  
[www.greensouthsolutions.com](http://www.greensouthsolutions.com)

February 9, 2021

Ms. Jennifer Bush  
City of Fairhope WWTP  
555 South Section Street  
Fairhope, Alabama 36532

RE: Contract Extension Request  
Bid No. 016-20 – Sludge Removal Services

Ms. Bush,

GreenSouth Solutions, LLC, requests that the above referenced Contract be extended for the period of one year from the expiration date of its current term. All current contract elements, pricing and terms are to remain the same for the extended term. We value our established relationship with the City and look forward to another year.

Thank you,

Cole E. Dunn  
Vice President

Alabama 40002

Florida (904) 660-594  
334-858-2622

Mississippi (601) 223

Asheville, North Carolina (704) 636-1000  
Cincinnati, Ohio (513) 263-1000  
Columbus, Ohio (614) 292-1000  
Dallas, Texas (972) 443-1000  
Denver, Colorado (303) 733-1000  
Detroit, Michigan (313) 963-1000  
Houston, Texas (281) 416-1000  
Indianapolis, Indiana (317) 443-1000  
Jacksonville, Florida (904) 243-1000  
Little Rock, Arkansas (501) 223-1000  
Louisville, Kentucky (502) 263-1000  
Miami, Florida (305) 443-1000  
Memphis, Tennessee (901) 223-1000  
Nashville, Tennessee (615) 223-1000  
New York, New York (212) 443-1000  
Orlando, Florida (407) 223-1000  
Phoenix, Arizona (602) 223-1000  
Portland, Oregon (503) 223-1000  
Raleigh, North Carolina (919) 223-1000  
San Antonio, Texas (214) 223-1000  
San Diego, California (619) 223-1000  
Seattle, Washington (206) 223-1000  
Tampa, Florida (813) 223-1000  
Wichita, Kansas (316) 223-1000



**CITY OF FAIRHOPE**

and

**GreenSouth Solutions, LLC**

**Extension 1**

**Bid 016-20 Sludge Removal Services 2020**

**Sherry Sullivan, Mayor  
Fairhope City Council  
Jack Burrell, Council President**

Set \_\_\_\_\_

City of Fairhope

Extension 1 of Bid 016-20 Sludge Removal Services 2020

This EXTENSION NO.1 of CONTRACT ("Extension") is made this \_\_\_\_ day of \_\_\_\_\_, 20\_\_\_\_, for the purpose of extending the agreement known as Bid 016-20 Sludge Removal Services 2020, dated March 10, 2021, ("Original Contract") between the City of Fairhope and GreenSouth Solutions, LLC (the "Parties").

1. The Original agreement, which is attached hereto as a part of this Extension, is described below:

Bid 016-20 Sludge Removal Services 2020

and will end on March 10, 2021 at midnight

2. The Parties agree to extend the Original agreement for an additional period, which will begin immediately upon the expiration of the original time period March 10, 2021 at midnight and will end on March 9, 2022 at midnight.

3. This Extension binds and benefits both Parties and any successors or assigns. This document, including the attached Original Contract, is the entire agreement between the Parties. All other terms and conditions of the Original Contract, including pricing, remain unchanged.

IN WITNESS WHEREOF, the parties hereto have executed this Contract Extension as of the day and year first above written.

THE CITY OF FAIRHOPE, ALABAMA

ATTEST:

\_\_\_\_\_  
BY: Sherry Sullivan, Mayor

\_\_\_\_\_  
BY: Lisa A. Hanks, MMC, City Clerk

NOTARY FOR THE CITY

STATE OF ALABAMA}  
COUNTY OF BALDWIN}

I, the undersigned authority in and for said State and County, hereby certify that Sherry Sullivan as Mayor of the City of Fairhope whose name is signed to the foregoing document and who is known to me, acknowledged before me on this day, being informed of the contents of the document she executed the same voluntarily on the date of the same bears date.

Given under my hand and Notary Seal on this \_\_\_\_ day of \_\_\_\_\_, 20\_\_\_\_.

Notary Public \_\_\_\_\_

My Commission Expires: \_\_\_\_\_

**If Corporation, Partnership, or Joint Venture**

\_\_\_\_\_  
Name of Corporation, Partnership, or Joint Venture

By: \_\_\_\_\_  
Signature of Officer Authorized to Sign Bids  
and Contracts for the Firm

\_\_\_\_\_  
Position or Title

\_\_\_\_\_  
Email Address

\_\_\_\_\_  
Business Mailing Address

\_\_\_\_\_  
City, State, Zip Code

\_\_\_\_\_  
General Contractor's License Number

\_\_\_\_\_  
Foreign Corporation Entity ID  
(Required of out-of-state vendors)

**NOTARY**

STATE OF \_\_\_\_\_ }

COUNTY OF \_\_\_\_\_ }

I, the undersigned authority in and for said State and County, hereby certify that

\_\_\_\_\_, as \_\_\_\_\_  
Type or Print Name of Bid Signer                      Type or Print Bid Signer Title

Respectively, of \_\_\_\_\_  
Type or Print Company Name

Whose name is signed to the foregoing document and who is known to me, acknowledged before me on this day, that, being of the contents of the document they executed the same voluntarily on the day the same bears date.

Given under my hand and Notary Seal on this \_\_\_\_\_ day of \_\_\_\_\_, 20\_\_

Notary Public \_\_\_\_\_

My Commission Expires \_\_\_\_\_



**RESOLUTION NO. \_\_\_\_\_**

**BE IT RESOLVED BY THE GOVERNING BODY OF THE CITY OF FAIRHOPE, ALABAMA, as follows:**

[1] That the City of Fairhope approves the procurement for Fly Creek Tree Removal caused by Hurricane Sally (FEMA 4563). The RFQ was sent to forty (40) contractors as well as multiple State agencies for MBE and DEB consideration. The City received five responsive and responsible quotes; and awards the project to Tonsmeire Construction, Inc. in the amount of \$24,602.50.

Adopted on this 22nd day of February, 2021

\_\_\_\_\_  
Jack Burrell, Council President

Attest:

\_\_\_\_\_  
Lisa A. Hanks, MMC  
City Clerk

City of Fairhope  
Project Funding Request

Issuing Date: 2/10/2021

Please return this Routing Sheet to Treasurer by: ASAP

Project Name: Award RFQ for Fly Creek tree removal caused by Hurricane Sally

FEB 10 21 10:23

*LAN*

Project Location: Fly Creek

Presented to City Council: 2/22/2021

Resolution # :  
Approved \_\_\_\_\_

Funding Request Sponsor: Richard Johnson, Public Works Director  
George Ladd, Supervisor Streets and Facilities Maintenance

Changed \_\_\_\_\_

Rejected \_\_\_\_\_

Project Cash Requirement Requested:  
Cost: \$ 24,602.50

\$ \_\_\_\_\_

Vendor: Tonsmeire Construction

Project Engineer: n/a

Order Date: n/a

Lead Time: n/a

Department Funding This Project

General  Gas  Electric  Water  Sewer  Gas Tax  Cap Project  Impact  Health  Fed Grant

Department of General Fund Providing the Funding

Admin-10  Bldg-13  Police-15  Fire-20  ECD-24  Rec-25  Civic-26  **Street-35**  Sanitation-40   
Fac Maint-45  Golf-50  Golf Grounds-55  Museum-70  Debt Service-85  Marina-34  Plan/Zone

Project will be:

Funding Source:

Expensed XXX   
Capitalized \_\_\_\_\_   
Inventoried \_\_\_\_\_

Operating Expenses XXX   
Budgeted Capital \_\_\_\_\_   
Unfunded \_\_\_\_\_

Expense Code: 001350-50360  
G/L Acct Name: General Maintenance

Grant: \_\_\_\_\_ Federal - not to exceed amount  
\_\_\_\_\_ State  
\_\_\_\_\_ City  
\$0.00 Local

Project Budgeted: \$ \_\_\_\_\_  
Balance Sheet Item  
Included in projected  
cash flow \_\_\_\_\_

Over (Under) budget amount: \$ 24,602.50

Bond: \_\_\_\_\_ Title \_\_\_\_\_ Year \_\_\_\_\_  
Loan: \_\_\_\_\_ Title \_\_\_\_\_ Year \_\_\_\_\_

Comments:  
FEMA eligible reimbursement is unknown

Capital Lease: \_\_\_\_\_ - Payment \_\_\_\_\_ Term \_\_\_\_\_

City Council Prior Approval/Date? \_\_\_\_\_

Finance Manager

City Treasurer

Mayor

Purchasing Memo Date: 2/5/2021

Purchasing Memo Date: 2/5/2021

Delivered To Date: 2/10/2021

Request Approved Date: 2/10/2021

Request Approved Date: 2/10/2021

Approved Date: \_\_\_\_\_

Signatures: *[Signature]*  
Jl Cabaniss, MBA

*[Signature]*  
Kim Creech

*[Signature]*  
Mayor Sherry Sullivan



## MEMO

To: Kimberly Creech, Treasurer

From:   
Delores A. Brandt, Purchasing Manager

Date: February 5, 2021

Sherry Sullivan  
Mayor

Re: **Greensheet/City Council agenda to approve the over \$10,000 acquisition of tree removal in Fly Creek caused by Hurricane Sally (FEMA 4563)**

*Council Members:*

Kevin G. Boone  
Robert A. Brown  
Jack Burrell, ACMO  
Jimmy Conyers  
Corey Martin

The Public Works Director, Richard Johnson has need to procure tree removal services for trees in Fly Creek felled as a result of Hurricane Sally (FEMA 4563) on or about September 15, 2020.

Lisa A. Hanks, MMC  
City Clerk

A request for quotes for Fly Creek Tree Removal was issued to forty (40) contractors as well as multiple state agencies for MBE and DBE consideration, was posted on the City website, and in the Public Utilities Building lobby. The City received five responsive and responsible submissions.

Kimberly Creech  
City Treasurer

The Director of Public Works recommends the award be made to **Tonsmeire Construction** in the amount of **TWENTY-FOUR THOUSAND SIX HUNDRED TWO DOLLARS AND FIFTY CENTS (\$24,602.50)**.

**Please prepare a greensheet and place on the next City Council Agenda this request to award the Fly Creek Tree Removal quote as a result of Hurricane Sally (FEMA 4563) to Tonsmeire Construction in the amount of \$24,602.50.**

Cc: File, R. Johnson, G. Ladd

161 North Section St.  
PO Drawer 429  
Fairhope, AL 36533

251-928-2136 (p)  
251-928-6776 (f)  
[www.fairhopeal.gov](http://www.fairhopeal.gov)

**CITY OF FAIRHOPE BID TABULATION**

**FLY CREEK TREE REMOVAL**

**DEADLINE TO SUBMIT: Monday, February 1, 2021, 10:00 a.m.**

**DIRECT RECIPIENTS: 40**

**RESPONSES RECEIVED: 5**

<b>Vendor</b>	<b>Quote Response Form</b>	<b>Anti-Lobbying Certification</b>	<b>Lump Sum Price</b>
Tonsmeire Construction	YES	YES	\$ 24,602.50
Coastline Solutions	YES	YES	\$ 97,750.00
Godfrey Environmental Solutions	YES	YES	\$ 124,014.14
Terraform Land	YES	YES	\$ 27,000.00
Wildlife Solutions	YES	YES	\$ 58,650.00

**Recommendation: Award Fly Creek Tree Removal to Tonsmeire Construction**



Richard Johnson, Public Works Director

02/05/2021

Date



Delores A. Brandt, Purchasing Manager

2-5-21

Date

## Jennifer Bush

---

**From:** Jennifer Bush  
**Sent:** Monday, January 25, 2021 10:36 AM  
**To:** 'david@gulfconstruction.com'; 'dwardau@gmail.com'; 'ashley@wfccorp.com'; 'bbledsoe@greencoll.com'; 'sycamoreinc@bellsouth.net'; 'egsherm@gulftel.com'; 'reefmaker@gulftel.com'; 'ascassity@gmail.com'; 'asc62173@gmail.com'; 'laura@mdthomasconstruction.com'; 'mrhtah@gulftel.com'; 'michaelstrength@att.net'; 'bwaters655@gmail.com'; 'samer@ubcllc.us'; 'natalie@charlesweems.com'; 'Meadowsw41@gmail.com'; 'marckc@hyperioncc.com'; 'mikekerrconstruction@hotmail.com'; 'kahlbau@bellsouth.net'; 'arringtoncurb@hotmail.com'; 'egillis@bellsouth.net'; 'gsmith@asi-gc.com'; 'steve@bladeconstruction.com'; 'lazzari1@outlook.com'; 'fenceandplay@yahoo.com'; 'lmathews@asplundh.com'; 'dbarrow@wakendall.com'; 'mwilliams@rdaservices.net'; 'paulbrazell@rdaservices.net'; 'bucky@gclnc.com'; 'ejgarrett@southernco.com'; 'srcochra@southernco.com'; 'cefosterjr@gmail.com'; 'jthomas10976@gmail.com'; 'jj@wildlifesolutionsinc.com'; 'brien@jubileelandscape.com'; 'emoran@wakendall.com'; 'curt202@aol.com'; 'rachel234@att.net'; 'office@ejbuilders.com'  
**Cc:** Scott.Stewart@adeca.alabama.gov; PTAC@ua.edu; Danielle.Barnes@aamu.edu; Natoya.sterling@aamu.edu; dmills@uwa.edu; sstoudemire@uwa.edu; Mike.self@contractorcn.com; cm@contractorcn.com; meadowss@dot.state.al.us; cdrake@tuscaloosa.com; wrightz@dot.state.al.us; Jennifer Bush  
**Subject:** City of Fairhope Fly Creek Tree Removal  
**Attachments:** Quote Fly Creek Tree Removal FEMA 4563.pdf

Please see attached quote for Fly Creek Tree Removal for the City of Fairhope. Deadline for submissions is Monday, February 1, 2021, 10:00 a.m.

This information can also be found online at <https://www.fairhopeal.gov/departments/purchasing/bids>.

Questions should be submitted in writing to [purchasing@fairhopeal.gov](mailto:purchasing@fairhopeal.gov).

## Jennifer Bush

Purchasing Administrative Assistant

555 S. Section Street  
Fairhope, AL 36532  
251-279-6231

APPLICABLE DRAWINGS AND SPECIFICATIONS (Attached and Below):

1. Attached map with GPS Points of surveyed tree locations.

Fly Creek Tree Removal Lump Sum Quote:

\$ 24,602.50

Contractor Name: Tansmeire Construction

Address: 6 S. Summit Street

City: Fairhope State: AL Zip: 36532

Contact Name: Elizabeth Phone: 348-4109

CERTIFICATION REGARDING LOBBYING

The undersigned certifies, to the best of his or her knowledge and belief, that:

(1) No Federal appropriated funds have been paid or will be paid, by or on behalf of the undersigned, to any person for influencing or attempting to influence an officer or employee of any agency, a Member of Congress, an officer or employee of Congress, or an employee of a Member of Congress in connection with the awarding of any Federal grant, the making of any Federal loan, the entering into of any cooperative agreement, and the extension, continuation, renewal, amendment or modification of any Federal contract, grant, loan, or cooperative agreement.

(2) If any funds other than Federal appropriated funds have been paid or will be paid to any person for influencing or attempting to influence an officer or employee of any agency, a Member of Congress, an officer or employee of Congress, or an employee of a Member of Congress in connection with this Federal contract, grant, loan, or cooperative agreement, the undersigned shall complete and submit Standard Form-LLL, "Disclosure of Lobbying Activities," in accordance with its instructions.

(3) The undersigned shall require that the language of this certification be included in the award documents of all sub-awards at all tiers (including subcontracts, sub-grants, and contracts under grants, loans, and cooperative agreements) and that all subrecipients shall certify and disclose accordingly.

This certification is a material representation of fact upon which reliance was placed when this transaction was made or entered into. Submission of this certification is a prerequisite for making or entering into this transaction imposed by section 1352, title 31, United States Code. Any person who fails to file the required certification shall be subject to a civil penalty of not less than \$10,000 and not more than \$100,000 for each such failure.

Organization: Tonsmeire Construction  
Street address: 65 Summit Street  
City, State, Zip: Fairhope, AL 36532  
CERTIFIED BY:(type or print) Elizabeth Tonsmeire  
TITLE: owner  
ETM (signature) 2.1.21 (date)

POST IN A  
CONSPICUOUS  
PLACE

# City of Fairhope, Alabama

Business License

THIS LICENSE EXPIRES 12/31/2020

License Number

3789

Business Name: TONSMEIRE CONSTRUCTION CORPORATION  
Address: 6 S SUMMIT ST  
City, State Zip: FAIRHOPE, AL 36532

# 20

ID: 100123

Phone Number:

This License is issued pursuant to Chapter 8 of the Code of Ordinances, City of Fairhope. License, or a copy thereof, must be posted in a conspicuous place where business is conducted and must be presented upon demand of any authorized City of Fairhope Officer.

Classification: CONTRACTORS-GENERAL CONTRACTORS, COMMERCIAL BLDG

Date Issued: 01/21/2020

License Base: CITY LIMITS



By

*[Signature]*  
Issuing Officer

This License is NOT Transferable - Office Copy Only

<p>This is your Business License Receipt</p>	<p><b>City of Fairhope, Alabama</b> Business License THIS LICENSE EXPIRES 12/31/2020</p>	<p>License Number 3789</p>
<p>Business Name: TONSMEIRE CONSTRUCTION CORPORATION ID: 100123 Address: 6 S SUMMIT ST City, State Zip: FAIRHOPE, AL 36532 Phone Number:</p>		
<p>This License is issued pursuant to Chapter 8 of the Code of Ordinances, City of Fairhope. License, or a copy thereof, must be posted in a conspicuous place where business is conducted and must be presented upon demand of any authorized City of Fairhope Officer.</p> <p>Classification: CONTRACTORS-GENERAL CONTRACTORS, COMMERCIAL BLDG Date Issued: 01/21/2020 License Base: CITY LIMITS</p> <p>By <i>[Signature]</i> Issuing Officer</p>	 <p>ISSUANCE FEE 12.00 License Fee: 100.00</p> <p>Total: 112.00</p>	





# CERTIFICATE OF LIABILITY INSURANCE

DATE (MM/DD/YYYY)  
07/24/2020

THIS CERTIFICATE IS ISSUED AS A MATTER OF INFORMATION ONLY AND CONFERS NO RIGHTS UPON THE CERTIFICATE HOLDER. THIS CERTIFICATE DOES NOT AFFIRMATIVELY OR NEGATIVELY AMEND, EXTEND OR ALTER THE COVERAGE AFFORDED BY THE POLICIES BELOW. THIS CERTIFICATE OF INSURANCE DOES NOT CONSTITUTE A CONTRACT BETWEEN THE ISSUING INSURER(S), AUTHORIZED REPRESENTATIVE OR PRODUCER, AND THE CERTIFICATE HOLDER.

**IMPORTANT:** If the certificate holder is an ADDITIONAL INSURED, the policy(ies) must have ADDITIONAL INSURED provisions or be endorsed. If SUBROGATION IS WAIVED, subject to the terms and conditions of the policy, certain policies may require an endorsement. A statement on this certificate does not confer rights to the certificate holder in lieu of such endorsement(s).

<b>PRODUCER</b> Pitman Insurance Agency PO Box 482  Fairhope AL 36533	<b>CONTACT NAME:</b> Lee Turner	
	<b>PHONE (A/C, No, Ext):</b> (251) 928-9786	<b>FAX (A/C, No):</b> (251) 928-4406
<b>E-MAIL ADDRESS:</b> Lee@pitmaninsurance.com		
<b>INSURER(S) AFFORDING COVERAGE</b>		<b>NAIC #</b>
<b>INSURER A:</b> Benchmark		41394
<b>INSURER B:</b>		
<b>INSURER C:</b>		
<b>INSURER D:</b>		
<b>INSURER E:</b>		
<b>INSURER F:</b>		

**INSURED** (251) 928-1656  
 Tonsmeire Construction Corporation  
 6 S Summit St  
 Fairhope AL 365322332

**COVERAGES**      **CERTIFICATE NUMBER:** Cert ID 1191      **REVISION NUMBER:**

THIS IS TO CERTIFY THAT THE POLICIES OF INSURANCE LISTED BELOW HAVE BEEN ISSUED TO THE INSURED NAMED ABOVE FOR THE POLICY PERIOD INDICATED. NOTWITHSTANDING ANY REQUIREMENT, TERM OR CONDITION OF ANY CONTRACT OR OTHER DOCUMENT WITH RESPECT TO WHICH THIS CERTIFICATE MAY BE ISSUED OR MAY PERTAIN, THE INSURANCE AFFORDED BY THE POLICIES DESCRIBED HEREIN IS SUBJECT TO ALL THE TERMS, EXCLUSIONS AND CONDITIONS OF SUCH POLICIES. LIMITS SHOWN MAY HAVE BEEN REDUCED BY PAID CLAIMS.

INSR LTR	TYPE OF INSURANCE	ADDL INSD	SUBR WVD	POLICY NUMBER	POLICY EFF (MM/DD/YYYY)	POLICY EXP (MM/DD/YYYY)	LIMITS
A	<input checked="" type="checkbox"/> COMMERCIAL GENERAL LIABILITY <input type="checkbox"/> CLAIMS-MADE <input checked="" type="checkbox"/> OCCUR  GENL AGGREGATE LIMIT APPLIES PER: <input checked="" type="checkbox"/> POLICY <input type="checkbox"/> PRO-JECT <input type="checkbox"/> LOC OTHER:			GLP00926	06/08/2020	06/08/2021	EACH OCCURRENCE \$ 1,000,000 DAMAGE TO RENTED PREMISES (Ea occurrence) \$ 100,000 MED EXP (Any one person) \$ 5,000 PERSONAL & ADV INJURY \$ 1,000,000 GENERAL AGGREGATE \$ 2,000,000 PRODUCTS - COMP/OP AGG \$ 2,000,000
	<b>AUTOMOBILE LIABILITY</b> <input type="checkbox"/> ANY AUTO <input type="checkbox"/> OWNED AUTOS ONLY <input type="checkbox"/> SCHEDULED AUTOS <input type="checkbox"/> HIRED AUTOS ONLY <input type="checkbox"/> NON-OWNED AUTOS ONLY						COMBINED SINGLE LIMIT (Ea accident) \$ BODILY INJURY (Per person) \$ BODILY INJURY (Per accident) \$ PROPERTY DAMAGE (Per accident) \$
	<input type="checkbox"/> UMBRELLA LIAB <input type="checkbox"/> OCCUR <input type="checkbox"/> EXCESS LIAB <input type="checkbox"/> CLAIMS-MADE <input type="checkbox"/> DED <input type="checkbox"/> RETENTION \$						EACH OCCURRENCE \$ AGGREGATE \$
	<b>WORKERS COMPENSATION AND EMPLOYERS' LIABILITY</b> ANY PROPRIETOR/PARTNER/EXECUTIVE OFFICER/MEMBER EXCLUDED? <input type="checkbox"/> Y/N    N/A If yes, describe under DESCRIPTION OF OPERATIONS below						<input type="checkbox"/> PER STATUTE <input type="checkbox"/> OTH-ER E.L. EACH ACCIDENT \$ E.L. DISEASE - EA EMPLOYEE \$ E.L. DISEASE - POLICY LIMIT \$

DESCRIPTION OF OPERATIONS / LOCATIONS / VEHICLES (ACORD 101, Additional Remarks Schedule, may be attached if more space is required)

<b>CERTIFICATE HOLDER</b>  Alabama License Board for General Contractors  2525 Fairlane Drive  Montgomery AL 36116	<b>CANCELLATION</b>  SHOULD ANY OF THE ABOVE DESCRIBED POLICIES BE CANCELLED BEFORE THE EXPIRATION DATE THEREOF, NOTICE WILL BE DELIVERED IN ACCORDANCE WITH THE POLICY PROVISIONS.
	<b>AUTHORIZED REPRESENTATIVE</b> <i>Lee Turner</i>

© 1988-2015 ACORD CORPORATION. All rights reserved.

**RESOLUTION NO. \_\_\_\_\_**

**BE IT RESOLVED BY THE GOVERNING BODY OF THE CITY OF FAIRHOPE, ALABAMA, as follows:**

[1] That the City of Fairhope approves the procurement for Wooden Pier Repairs damaged by Hurricane Sally (FEMA 4563). RFQ 2021-PWI 006 was sent to twenty-five (25) contractors as well as multiple State agencies for MBE and DEB consideration. The City received two responsive and responsible submissions; and awards the project to Asphalt Services, Inc. in the amount of \$60,119.00. An insurance claim has been filed; and once the claim is done, then FEMA claim will be submitted.

Adopted on this 22nd day of February, 2021

\_\_\_\_\_  
Jack Burrell, Council President

Attest:

\_\_\_\_\_  
Lisa A. Hanks, MMC  
City Clerk

City of Fairhope  
Project Funding Request

Issuing Date: 2/10/2021

Please return this Routing Sheet to Treasurer by: ASAP

Project Name: Award RFQ 2021-PWI 006 Wooden Pier Repairs caused by Hurricane Sally

Project Location: North Beach Park and Pecan Avenue Pier

Presented to City Council: 2/22/2021

Resolution #: Approved \_\_\_\_\_

Funding Request Sponsor: Richard Johnson, Public Works Director  
George Ladd, Supervisor Streets and Facilities Maintenance

Changed FEB 10 '21 PM 3:30

Rejected \_\_\_\_\_

Project Cash Requirement Requested:  
Cost: \$ 60,119.00

Vendor: Asphalt Services, Inc.

Project Engineer: n/a

Order Date: n/a Lead Time: n/a

Department Funding This Project

General  Gas  Electric  Water  Sewer  Gas Tax  Cap Project  Impact  Health  Fed Grant

Department of General Fund Providing the Funding

Admin-10  Bldg-13  Police-15  Fire-20  ECD-24  Rec-25  Civic-26  Street-35  Sanitation-40   
Fac Maint-45  Golf-50  Golf Grounds-55  Museum-70  Debt Service-85  Marina-34  Plan/Zone

Project will be:

Expensed XXX   
Capitalized \_\_\_\_\_   
Inventoried \_\_\_\_\_

Funding Source:

Operating Expenses XXX   
Budgeted Capital \_\_\_\_\_   
Unfunded \_\_\_\_\_

Expense Code: 001350-50475  
G/L Acct Name: Capital Improvements

Grant: \_\_\_\_\_ Federal - not to exceed amount  
\_\_\_\_\_ State  
\_\_\_\_\_ City  
\$0.00 Local

Project Budgeted: \$ \_\_\_\_\_ - FEMA reimbursement 87.5%  
Balance Sheet Item-  
Included in projected  
cash flow \_\_\_\_\_

Over (Under) budget amount: \$ 60,119.00

Bond: \_\_\_\_\_ Title \_\_\_\_\_ Year \_\_\_\_\_  
Loan: \_\_\_\_\_ Title \_\_\_\_\_ Year \_\_\_\_\_

Comments: \_\_\_\_\_

Capital Lease: \_\_\_\_\_ - Payment \_\_\_\_\_ Term \_\_\_\_\_

City Council Prior Approval/Date? \_\_\_\_\_

Finance Manager

City Treasurer

Mayor

Purchasing Memo Date: 2/5/2021

Purchasing Memo Date: 2/5/2021

Delivered To Date: 2/10/2021

Request Approved Date: 2/10/2021

Request Approved Date: 2/10/2021

Approved Date: \_\_\_\_\_

Signatures:

Kim Creech

Mayor Cheryl Sullivan



## MEMO

To: Kimberly Creech, Treasurer

From: *Delores A Brandt*  
Delores A. Brandt, Purchasing Manager

Date: February 5, 2021

Sherry Sullivan  
Mayor

*Council Members:*

Kevin G. Boone  
Robert A. Brown  
Jack Burrell, ACMO  
Jimmy Conyers  
Corey Martin

Lisa A. Hanks, MMC  
City Clerk

Kimberly Creech  
City Treasurer

**Re: Greensheet/City Council agenda to approve the over \$10,000 acquisition of Wooden Pier Repairs caused by Hurricane Sally (FEMA 4563)**

The Public Works Director, Richard Johnson has need to procure wooden pier repairs at North Beach Park and Pecan Avenue as a result of Hurricane Sally (FEMA 4563) on or about September 15, 2020.

A request for quotes for Wooden Pier Repairs was issued to twenty-five (25) contractors as well as multiple state agencies for MBE and DBE consideration, was posted on the City website, and in the Public Utilities Building lobby. The City received two responsive and responsible submissions.

The Director of Public Works recommends the award be made to **Asphalt Services, Inc.** in the amount of **SIXTY THOUSAND ONE HUNDRED AND NINETEEN DOLLARS AND ZERO CENTS (\$60,119.00)**.

**Please prepare a greensheet and place on the next City Council Agenda this request to award the Wooden Pier Repairs quote as a result of Hurricane Sally (FEMA 4563) to Asphalt Services, Inc. in the amount of \$60,119.00.**

Cc: File, R. Johnson, G. Ladd

161 North Section St.  
PO Drawer 429  
Fairhope, AL 36533

251-928-2136 (p)  
251-928-6776 (f)  
[www.fairhopeal.gov](http://www.fairhopeal.gov)

**CITY OF FAIRHOPE BID TABULATION**

**WOODEN PIER REPAIR**

**DEADLINE TO SUBMIT: Wednesday, February 3, 2021, 10:00 a.m.**

**DIRECT RECIPIENTS: 25**

**RESPONSES RECEIVED: 2**

<b>Vendor</b>	<b>Quote Response Form</b>	<b>Anti-Lobbying Certification</b>	<b>Lump Sum Price</b>
Asphalt Services, Inc.	YES	YES	\$ 60,119.00
Godfrey Environmental Solutions	YES	YES	\$ 153,208.95

**Recommendation: Award Wooden Pier Repair to Asphalt Services, Inc.**

  
\_\_\_\_\_  
Richard Johnson, Public Works Director

02/05/2021  
Date

  
\_\_\_\_\_  
Delores A. Brandt, Purchasing Manager

02-05-21  
Date

## Jennifer Bush

---

**From:** Jennifer Bush  
**Sent:** Monday, January 25, 2021 10:36 AM  
**To:** 'david@gulfconstruction.com'; 'dwardau@gmail.com'; 'ashley@wfccorp.com'; 'bbledsoe@greencoll.com'; 'sycamoreinc@bellsouth.net'; 'egsherm@gulftel.com'; 'reefmaker@gulftel.com'; 'ascassity@gmail.com'; 'asc62173@gmail.com'; 'laura@mdthomasconstruction.com'; 'mrhtah@gulftel.com'; 'michaelstrength@att.net'; 'bwaters655@gmail.com'; 'samer@ubcllc.us'; 'natalie@charlesweems.com'; 'Meadowsw41@gmail.com'; 'marckc@hyperioncc.com'; 'mikekerrconstruction@hotmail.com'; 'kahlbau@bellsouth.net'; 'arringtoncurb@hotmail.com'; 'egillis@bellsouth.net'; 'gsmith@asi-gc.com'; 'steve@bladeconstruction.com'; lazzari1@outlook.com; fenceandplay@yahoo.com  
**Cc:** Scott.Stewart@adeca.alabama.gov; PTAC@ua.edu; Danielle.Barnes@aamu.edu; Natoya.sterling@aamu.edu; dmills@uwa.edu; sstoudemire@uwa.edu; Mike.self@contractorcn.com; cm@contractorcn.com; meadowss@dot.state.al.us; cdrake@tuscaloosa.com; wrightz@dot.state.al.us; Jennifer Bush  
**Subject:** City of Fairhope Wooden Pier Repair  
**Attachments:** Quote Wooden Pier Repair FEMA 4563.pdf

Please see attached quote request for Wooden Pier Repairs for the City of Fairhope. Deadline for submissions is Wednesday, February 3, 2021 at 10:00 a.m..

This information can also be found online at <https://www.fairhopeal.gov/departments/purchasing/bids>.

Questions should be submitted in writing to [deedee.brandt@fairhopeal.gov](mailto:deedee.brandt@fairhopeal.gov).

## Jennifer Bush

Purchasing Administrative Assistant

555 S. Section Street  
Fairhope, AL 36532  
251-279-6231

# ASPHALT SERVICES, INC.



*PROPOSAL FOR:*

THE CITY OF FAIRHOPE

WOODEN PIER REPAIRS

PROJECT NO. 2021-PWI 006

FEBRUARY 3, 2021 @ 10:00 A.M.

**CITY OF FAIRHOPE  
REQUEST FOR QUOTATIONS  
COVER SHEET**

The following Request for Quotation is related to damages caused by Hurricane Sally  
(FEMA 4563) on or about September 15, 2020.

**Wooden Pier Repairs**

**Date Issued:** January 25, 2021

**Deadline to Submit:** Wednesday, February 3, 2021, 10:00 a.m.

**Direct all Questions To:** Dee Dee Brandt, Purchasing Manager  
[DeeDee.Brandt@fairhopeal.gov](mailto:DeeDee.Brandt@fairhopeal.gov)

**Submitted Quotes Should Include:** Completed Quote Response form  
Anti-Lobbying Certification  
Other supporting documentation as requested

**Deliver Quotes To:** Public Works Building  
555 S. Section Street  
Fairhope, AL 36532

**Email Quotes To:** Dee Dee Brandt, Purchasing Manager  
[DeeDee.Brandt@fairhopeal.gov](mailto:DeeDee.Brandt@fairhopeal.gov)

For emailed quotes, please reference the Wooden Pier Repairs in the subject line.



## GENERAL CONDITIONS, SPECIAL PROVISIONS and SUPPLEMENTAL SPECIFICATIONS

1. **SAFETY AND HEALTH REGULATIONS FOR CONSTRUCTION:** The Contractor shall comply with the Department of Labor Safety and Health Regulations for construction promulgated under the Occupational Safety and Health Act of 1970 (PL-596) and under Section 107 of the Contract Work Hours and Safety Standards Act (PL-91-54).

The contractor alone shall be responsible for the safety, efficiency, and adequacy of his plant, appliances, and methods, and for any damage which may result from their failure or their improper construction, maintenance, or operations.

2. **DEPARTMENT OF TRANSPORTATION SPECIFICATIONS:** It is the intent of the Public Works Director to construct the within described improvements in accordance with the State of Alabama Highway Department Standard Specifications for Highway Construction, most current edition. Said specifications shall be hereafter referred to as the Highway Department Specifications.

All provisions enumerated in the Highway Department Specifications shall be complied with, except as otherwise revised herein. Where certain modifications in said specifications appear in these specifications, only the modifications apply; otherwise, the standard specifications apply.

In said specifications where the words State of Alabama, Governor, State Highway Department, Director, etc., appear, substitute the Owner. Where the word Engineer appears, it shall mean Public Works Director. Where the words Testing Laboratory and/or Laboratory appear, it shall mean the particular Testing Laboratory retained by the Owner for this work.

3. **DEPARTMENT OF TRANSPORTATION DRAWINGS:** Where State of Alabama Department of Transportation Alabama Standard Drawings are applicable for the work required, they shall be considered as part of the plans, and copies of required drawings will be afforded the Contractor for construction purposes.
4. **PROJECT SITE:** The Contractor shall keep the project site clean at all times. No loose dirt, or stockpiles shall be left in areas other than those areas approved by the Public Works Director. The Public Works Director may require the Contractor to clean up any portion of the Project as he deems necessary. Construction & Demolition (C&D) must be cleaned up daily.
5. **MATERIALS:** The Contractor agrees to comply with, and to require the compliance of all subcontractors with the provisions of Act #876 of the Legislature of Alabama, adopted on September 8, 1961, requiring purchase of materials and supplies and products for the project which are manufactured, mined, processed, or otherwise produced in the United States or its territories if the same are available at reasonable prices; and the Contractor further agrees and stipulates to pay to the Owner a sum to be determined and fixed by the Owner in an amount not less than five hundred (\$500.00) dollars nor more than twenty (20%) percent of the gross amount of the Contract in the event he or any subcontractor breach this agreement to use domestic products.
6. **REPAIRS TO EXISTING PIERS:** This work shall include furnishing all labor, equipment, materials and all incidentals necessary to rebuild, reinforce and/or repair City-owned piers on the Eastern Shore of Mobile Bay. Work includes, but is not limited to: replacement of wooden piles, repair and/or replacement of pile caps (beams), stringers, decking, railings, steps, fishing docks, covered piers and all other pier related infrastructure(s) at the following City of Fairhope Piers:
  - a. North Beach Park – North Pier
  - b. North Beach Park – South Pier
  - c. Pecan Avenue Pier

Materials and workmanship shall be per the enclosed plans and specifications. Some work will involve field investigation and "design build" prior to repair. All proposed field modifications and "design builds" shall be reviewed and approved by the Public Works Director prior to Contractors initiation of work.

City of Fairhope, Public Works Department  
555 South Section Street Fairhope, Alabama 36532  
Phone: (251) 928-8003

## GENERAL CONDITIONS, SPECIAL PROVISIONS and SUPPLEMENTAL SPECIFICATIONS

7. **PUBLIC CONVENIENCE:** No attempt is made to restrict work hours of the Contractor's operations, but he is reminded that it will be necessary to arrange his work schedule to provide the least inconvenience to the public and individual residents. The Contractor shall take extra precaution to insure that traffic is protected by the use of, but not limited to, flashing signs and barrels. No direct payment will be made for any of the work described in this section.
8. **EROSION CONTROL:** Immediately prior to any clearing and grubbing or any excavation which could disturb the soils, the Contractor shall install the erosion control items in locations as required by the nature of the work performed. The provide Erosion Control Plan shall be considered the minimum requirement for the project.

The Contractor will be responsible for identifying and installing erosion control in areas where erosion may be encountered during construction of the project. The Contractor shall take all necessary precautions to insure that the construction of the project and the erosion/sediment from the project are adequately controlled and do not damage streams or adjacent property.

The erosion control items installed shall be maintained by the Contractor throughout the course of the project. The City of Fairhope's Environmental Programs Manager shall be the final authority for corrective action, remediation, requirement of additional BMP's and all other directives required for erosion/sediment control.

9. **UNDERGROUND UTILITIES AND SERVICES:** Existing utilities, mailboxes, signs and minor obstructions are not shown on the plans. Their presence, and the required removal and the resetting thereof shall be considered incidental to the overall project and the cost for the work noted above shall be included in the overall "lump sum" price for the project (no separate payment).

The Contractor is solely responsible for the locating all existing Utilities and Services. Failure of the Contractor to locate any utility does not justify additional payment to the Contractor if said utility is damaged. The Contractor must notify the utility companies involved prior to starting construction and shall make every effort not to damage any utilities. If utilities are damaged by the Contractor, the Contractor must pay all expenses incurred in the repair at no cost to the Owner or his representatives.

10. **PROVISIONS REQUIRED BY LAW DEEMED INSERTED:** Each and every provision of law and clause required by law to be inserted in this contract shall be deemed to be inserted herein and the contract shall be read and enforced as though it were included herein, and if through mistake or otherwise any such provision is not inserted, or is not correctly inserted, then upon the application of either party the contract shall forthwith be physically amended to make such insertion or correction.
11. **PROTECTION OF LIVES AND HEALTH:** "The Contractor shall exercise proper precaution at all times for the protection of persons and property and shall be responsible for all damages to persons or property, either on or off the site, which occur as a result of his prosecution of the work. The safety provisions of applicable laws and building and construction codes, in addition to specific safety and health regulations described by Chapter XIII, Bureau of Labor Standards, Department of Labor, Part 1518, Safety and Health Regulations for Construction, as outlined in the Federal Register, Volume 36, No. 75, Saturday, April 17, 1971. Title 29 - LABOR, shall be observed and the Contractor shall take or cause to be taken, such additional safety and health measures as the Contracting Authority may determine to be reasonably necessary."
12. **PUBLIC WORKS DIRECTOR'S AUTHORITY:** The Public Works Director shall give all orders and directions contemplated under this contract and specifications, relative to the execution of the work. The Public Works Director shall determine the amount, quality, acceptability, and fitness of

City of Fairhope, Public Works Department  
555 South Section Street Fairhope, Alabama 36532  
Phone: (251) 928-8003

## **GENERAL CONDITIONS, SPECIAL PROVISIONS and SUPPLEMENTAL SPECIFICATIONS**

the several kinds of work and materials which are to be paid for under this contract and shall decide all questions which may arise in relation to said work and the construction thereof. The Public Works Director's estimates and decisions shall be final and conclusive, except as herein otherwise expressly provided. In case any question shall arise between the parties hereto relative to said contract or specifications, the determination or decision of the Public Works Director's shall be a condition precedent to the right of the Contractor to receive any money or payment for work under this contract affected in any manner or to any extent by such question.

The Public Works Director shall decide the meaning and intent of any portion of the specifications and of any plans or drawings where the same may be found obscure or be in dispute. Any differences or conflicts in regard to their work which may arise between the Contractor under this contract and other Contractors performing work for the Owner shall be adjusted and determined by the Public Works Director.

- 13. USE OF PREMISES AND REMOVAL OF DEBRIS:** The Contractor expressly undertakes at his own expense:
- a. to take every precaution against injuries to persons or damage to property;
  - b. to store his apparatus, materials, supplies and equipment in such orderly fashion at the site of the work as will not unduly interfere with the progress of his work or the work of any other contractors;
  - c. to place upon the work or any part thereof only such loads as are consistent with the safety of that portion of the work; materials, and debris caused by his operations, to the end that at all times the site of the work shall present a neat, orderly and workmanlike appearance;
  - d. before final payment to remove all surplus material, false-work, temporary structures, including foundations thereof, plant of any description and debris of every nature resulting from his operations, and to put the site in a neat, orderly condition;
  - e. to effect all cutting, fitting or patching of his work required to make the same to conform to the plans and specifications and, except with the consent of the Public Works Director, not to cut or otherwise alter the work of any other Contractor.
  - f. The removal and proper disposal of all construction and demolition (C&D) debris is the contractor's responsibility. The cost of such removal and disposal shall be a subsidiary obligation of the related works unit costs.
- 14. INSURANCE:** The Contractor shall not commence work under this contract until he has obtained all the insurance required under the terms of this contract.
- 15. STATE OF ALABAMA GENERAL CONTRACTOR LICENSE:** Any proposed bidder for this project must possess and maintain a valid Alabama General Contractor (GC) License to qualify to submit bids in the state of Alabama (Code of Alabama; Section 34-8-8). The license must be maintained and valid throughout the contract period. The prime contractor may receive bids from unlicensed subcontractors; however the subcontractor must be licensed before beginning work (Code of Alabama; Section 34-8-7). A copy of all GC Licenses must be provided by the Pre-Construction Conference.
- 16. CITY OF FAIRHOPE BUSINESS LICENSE:** The Contractor shall not commence work under this contract until he has obtained a City of Fairhope Business License. The license must be maintained and valid throughout the contract period. A copy of the Business License must be provided by the Pre-Construction Conference.
- 17. MATERIALS, SERVICES AND FACILITIES:**
- a. It is understood that except as otherwise specifically stated in the Contract Documents, the Contractor shall provide and pay for all materials, labor, tools, equipment, water, light, power, transportation, supervision, temporary construction of every nature, and all other

## **GENERAL CONDITIONS, SPECIAL PROVISIONS and SUPPLEMENTAL SPECIFICATIONS**

services and facilities of every nature whatsoever necessary to execute, complete and deliver the work within the specified time.

- b. Any work necessary to be performed after regular working hours, on Sundays or Legal Holidays, shall be performed without additional expense to the Owner.

**18. CONTRACTOR'S TITLE TO MATERIALS:** No materials or supplies for the work shall be purchased by the Contractor or by any Subcontractor subject to any chattel mortgage or under a conditional sale contract or other agreement by which an interest is retained by the seller. The Contractor warrants that he has good title to all materials and supplies used by him in the work, free from all liens, claims or encumbrances.

**19. INSPECTION AND TESTING OF MATERIALS:**

- a. All materials and equipment used in the construction of the project shall be subject to adequate inspection and testing in accordance with accepted standards. The laboratory or inspection agency shall be selected by the Owner. The Owner will pay for all laboratory inspection service direct, and not as a part of the contract.
- b. Materials of construction, particularly those upon which the strength and durability of the structure may depend, shall be subject to inspection and testing to establish conformance with specification and suitability for uses intended.

**20. QUANTITIES AND PAYMENTS:** Quantities provided are best estimates and may vary with field conditions. Contractor should field verify prior to bidding. Payment will be made on actual measured quantities of work/materials preformed. No mobilization/demobilization shall be quantified or separately paid. Mobilization/demobilization shall be a subsidiary obligation of the quoted unit prices in the aggregate. Only two pay requests will be entertained: payment at substantial completion and release of retainage at final acceptance. A 10% retainage will be applied to the project – retainage will be paid at completion of project close out.

**21. CONTRACT TIME:** Contract time for this project shall be thirty (30) Calendar days from the Notice to Proceed date.

**22. FAILURE TO COMPLETE WORK WITHIN CONTRACT TIME:** Should the Contractor, or in case of default, the surety, fail to complete the work within the time stipulated in the contract or the adjusted time as granted under the provisions of this contract, a deduction for each calendar day that any work shall remain uncompleted, an amount of **\$125.00 (one-hundred and twenty-five and no/100)** shall be deducted from any monies due the Contractor on pay estimates. Any adjustments due to approved time extensions or overruns in the contract amount will be made only after written request by the contractor as may be appropriate. Liquidated damages assessed as provided in these Specifications is not a penalty, but is intended to compensate the City for increased time in administering the contract, supervision, inspection and management, particularly that management and inspection which requires maintaining normal field project management forces for a longer time on any construction operation or phase than originally contemplated when the contract period was agreed upon in the contract. Permitting the Contractor to continue and finish the work or any part of it after the time fixed for its completion, or after the date to which the time for completion may have been extended, will in no way operate as a waiver on the part of the City of any of its rights under the contract.

**23. MATERIAL SPECIFICATIONS:**

- a. Piles:
  - i. Minimum Diameter (Large end of taper 12", small end of taper 8")
  - ii. Pressure Treated 2.5 pcf CCA
  - iii. Piling Penetration Shall be the Greater of: 10' Penetration into ground or 1/3 total length of pile. Contractor is to Determine the Length of Piling Needed To Meet This Requirement.

City of Fairhope, Public Works Department  
555 South Section Street Fairhope, Alabama 36532  
Phone: (251) 928-8003

**GENERAL CONDITIONS, SPECIAL PROVISIONS and SUPPLEMENTAL SPECIFICATIONS**

- iv. For new piles with exposed tops - Top of Piling Shall Be Sanded Smooth and Edges Rounded 1/4"
- b. Dimensional Lumber:
  - i. No. 1, Pressure Treated (2.5 pcf CCA), Southern Yellow Pine
  - ii. Deck Boards and Rail Caps shall be No. 1, Pressure Treated (2.5 pcf CCA), Southern Yellow Pine with Radius Edge
- c. Rough Cut Lumber (Pile Caps (Beams))
  - i. No. 1, Pressure Treated (2.5 pcf CCA), Southern Yellow Pine
- d. Fasteners & Hardware:
  - i. Deck Screws - #10 x 3.5-in Countersinking-Head Polymer-Coated Deck Screws - minimum 2 screws per stringer and/or connection point.
  - ii. Through Bolts (fastening pile caps (beams) and stringers to piles) - 5/8"  $\emptyset$  hot dipped galvanized steel with 2 1/2 X 2 1/2 X 1/4 hot dipped galvanized plate washers.
  - iii. Stringer to Pile Cap (Beam) Fastener - 1 1/2" X 1 1/2" X 1/8" X 12" length Hot Dipped Galvanized Steel Angle with 1/4"  $\emptyset$  Stainless Through Bolts into Pre-Drilled Holes.
  - iv. Nails – No nails shall be used for final mechanical connection. Nails may be used for temporary shoring and setting of structure. Any nails used must be compliant for use with treated wood in a saltwater/air environment.

# NORTH BEACH PARK & PECAN AVE WOODEN PIER REPAIRS HURRICANE DAMAGE - CITY OF FAIRHOPE

JANUARY 2021



**MAYOR**

Sherry Sullivan

**CITY COUNCIL**

Kevin G. Boone  
Robert A. Brown  
Jack Burrell, ACMO  
Jimmy Conyers  
Corey Martin

**DIRECTOR OF PUBLIC WORKS**

Richard D. Johnson, PE

**CITY CLERK**

Lisa A. Hanks, MMC

INDEX TO SHEETS

SHEET	DESCRIPTION
1	Title
2	North Pier Repair Plan
3	South Pier Repair Plan
4	Pecan Avenue Pier Repair Plan
5	Pier Repair Typical Details



*Richard D. Johnson*  
Richard D. Johnson  
AL REG. NO. 30405

01-12-2021  
Date

**Project: 2021 - PWI 006  
Bid Set Drawings**



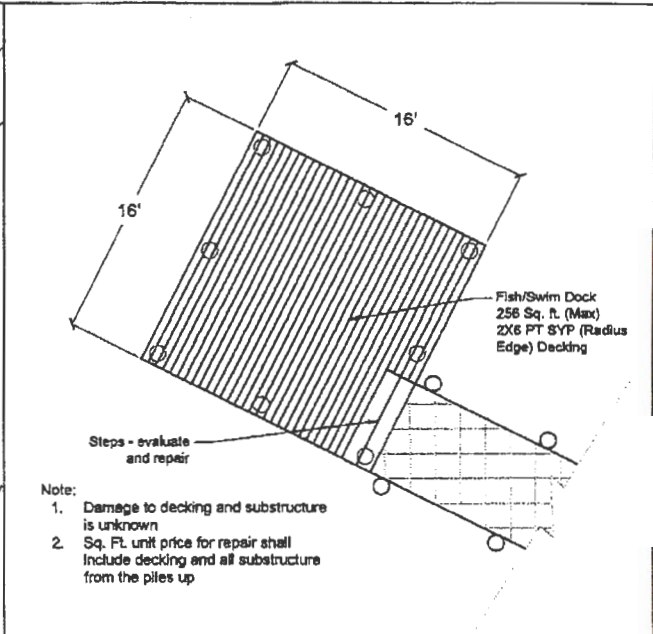
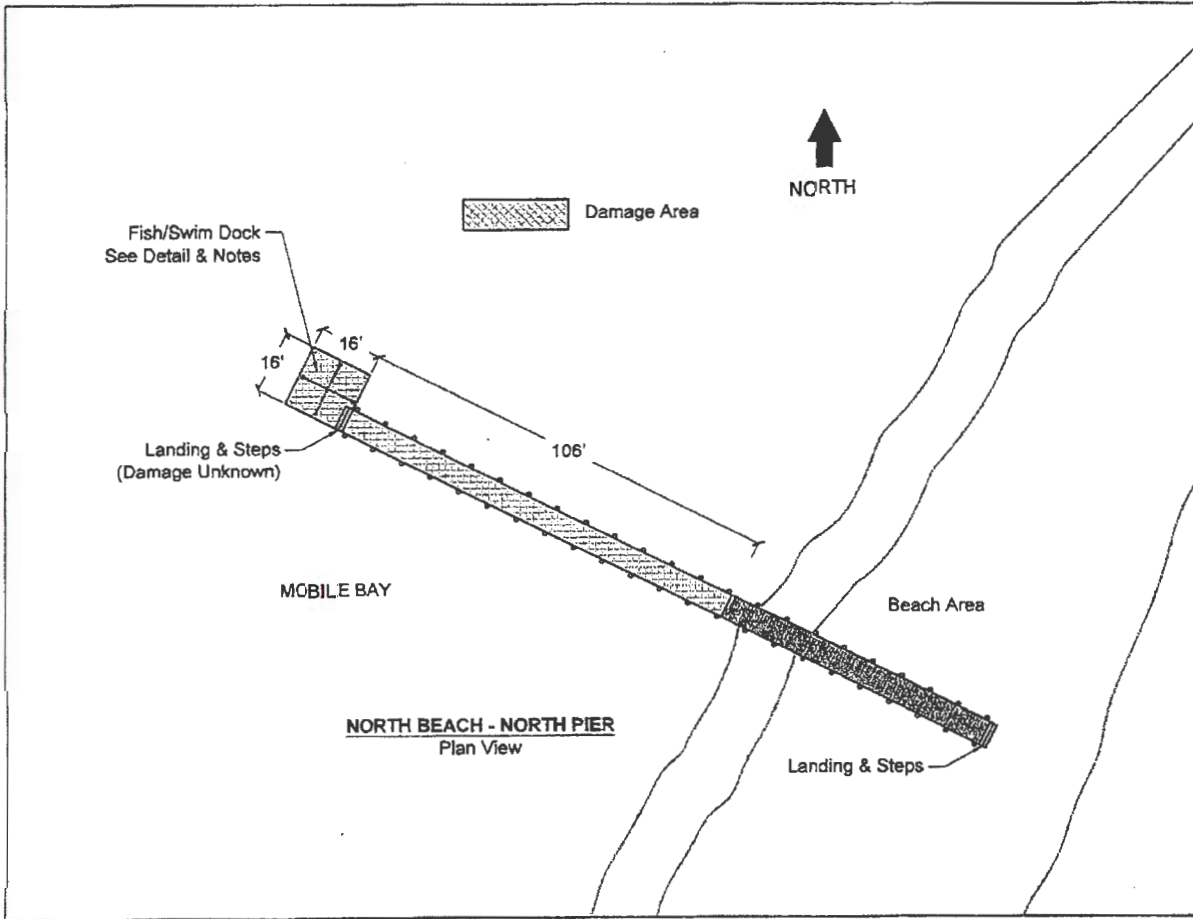

- Note:
1. Damage to decking and substructure is unknown
  2. Sq. Ft. unit price for repair shall include decking and all substructure from the piles up

**FISH/SWIM  
DOCK DETAIL**

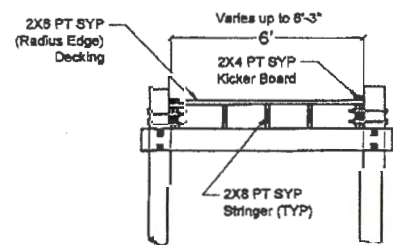

**TYPICAL PIER  
CROSS SECTION**

- NOTES:
1. All wood shall be No. 1, Pressure Treated (2.5 CCA), Southern Yellow Pine - Decking 2"x8" (Radius Edge); Stringers 2"x8"; Pile Caps (Beam) 2"x8" Rough Cut.
  2. If new piles are required - Piling Penetration Shall be the Greater of: 10' Penetration into ground or 1/3 total length of pile Contractor is to Determine the Length of Piling Needed To Meet This Requirement. IF for new piles with exposed tops - Top of Piling Shall Be Sanded Smooth and Edges Rounded 1/2"
  3. Decking and 2" dimensional railings shall be installed using #10 x 3.5-In Countersinking-Head Polymer-Coated Deck Screws - minimum 2 screws per stringer and/or connection point.
  4. All through bolts fastening pile caps (beams) and stringers to piles shall be 3/4" Ø hot dipped galvanized steel with 2 1/2 x 2 1/2 x 1/2 hot dipped galvanized plate washer.
  5. All quantities are approximate, the contractor shall visit site prior to bidding and field verify quantities and extents of damage.
  6. All work proposed should match dimensions and geometric's of existing structure(s). Any areas of conflict should be addressed with the Director of Public Works prior to work.

<b>NORTH BEACH - NORTH PIER REPAIR PLAN</b>		
City of Fairhope	Dept. of Public Works	Drawn By: RDJ
Project #: 2021-PM 006		Scale: N.T.S.
Date: 11/06/20	Permit Dwg (01/12/21)	Sheet 2 of 5

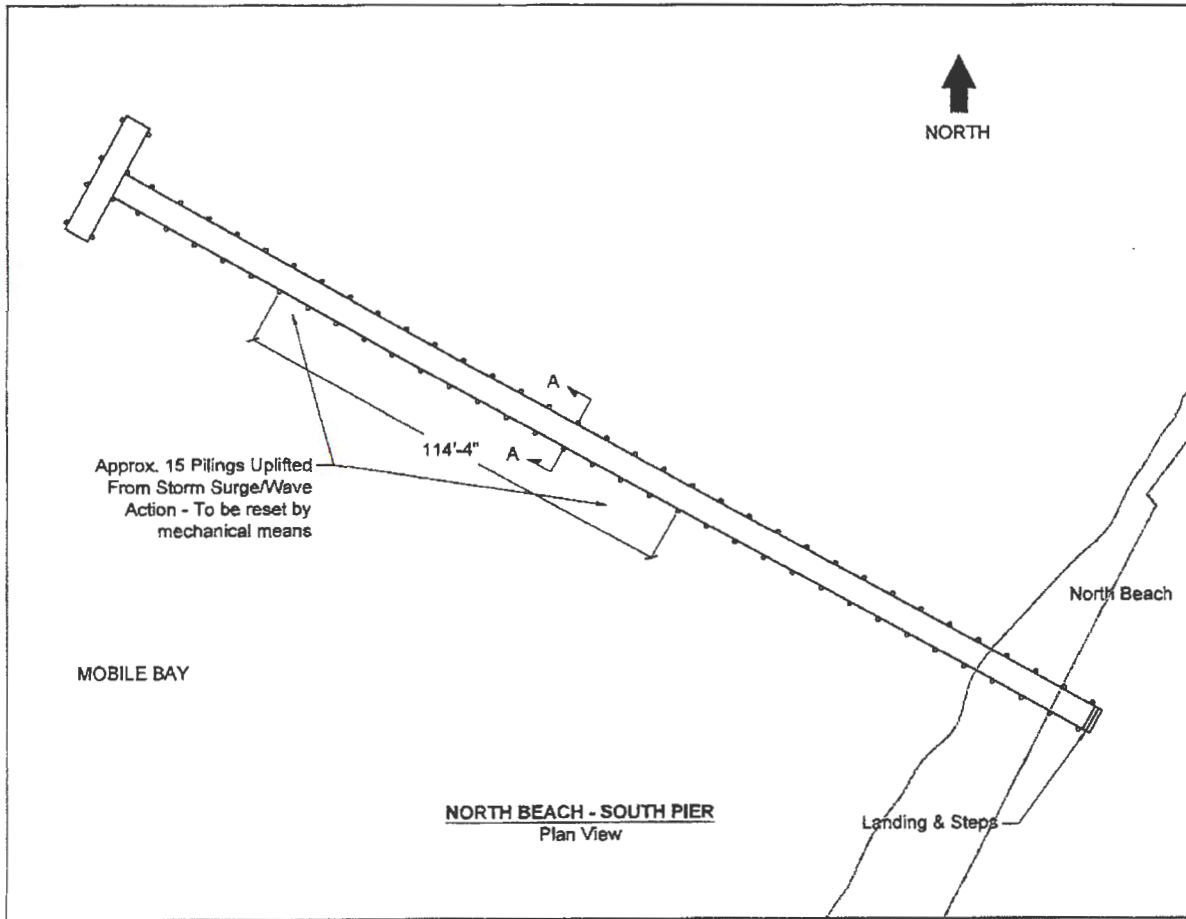

**NORTH BEACH - SOUTH PIER**  
Plan View

**PIER REPAIR NOTES:**

1. It is the intent of this repair to reset the piles to level pier without damaging intact sub and superstructure.
2. Contractor shall have latitude on how to conduct the work:
  - 2.1. Piles can be mechanically driven from shallow-draft barge on water.
  - 2.2. Piles can be reset by jetting as long as turbidity control measures are employed.
3. Post pile resetting contractor shall tighten and refasten all loose hardware and fasteners.
4. All work proposed should match dimensions and geometric's of existing structure(s). Any areas of conflict should be addressed with the Director of Public Works prior to work.
5. All new and repair work shall be conducted and completed without damage to the existing pier structures and the existing piles.

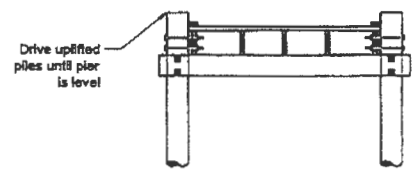

**TYPICAL PIER REPAIRED CROSS SECTION**

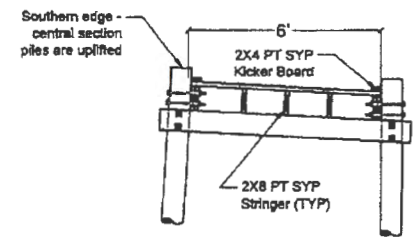

**SECTION A - A DAMAGED PIER CROSS SECTION**

**NOTES:**

1. All wood shall be No. 1, Pressure Treated (2.5 CCA), Southern Yellow Pine - Decking 2"x8" (Radius Edge); Stringers 2"x8"; Pile Caps (Beam) 2"x8" Rough Cut.
2. If new piles are required - Piling Penetration Shall be the Greater of: 10' Penetration into ground or 1/3 total length of pile Contractor is to Determine the Length of Piling Needed To Meet This Requirement. If new piles are required - Piling Penetration Shall be the Greater of: 10' Penetration into ground or 1/3 total length of pile Contractor is to Determine the Length of Piling Needed To Meet This Requirement. For new piles with exposed tops - Top of Piling Shall Be Sanded Smooth and Edges Rounded 1/4"
3. Decking and 2" dimensional railings shall be installed using #10 x 3.5-in Countersinking-Head Polymer-Coated Deck Screws - minimum 2 screws per stringer and/or connection point.
4. All through bolts fastening pile caps (beams) and stringers to piles shall be 5/8" Ø hot dipped galvanized steel with 2 1/2 x 2 1/2 x 1/4 hot dipped galvanized plate washer.
5. All quantities are approximate, the contractor shall visit site prior to bidding and field verify quantities and extents of damage.
6. All work proposed should match dimensions and geometric's of existing structure(s). Any areas of conflict should be addressed with the Director of Public Works prior to work.

NORTH BEACH - SOUTH PIER REPAIR PLAN		
City of Fairhope	Dept. of Public Works	Drawn By: RDJ
Project #: 2021-PWI 006		Scale: N.T.S.
Date: 11/06/2020	Permit Dwg (01/12/21)	Sheet 3 of 5



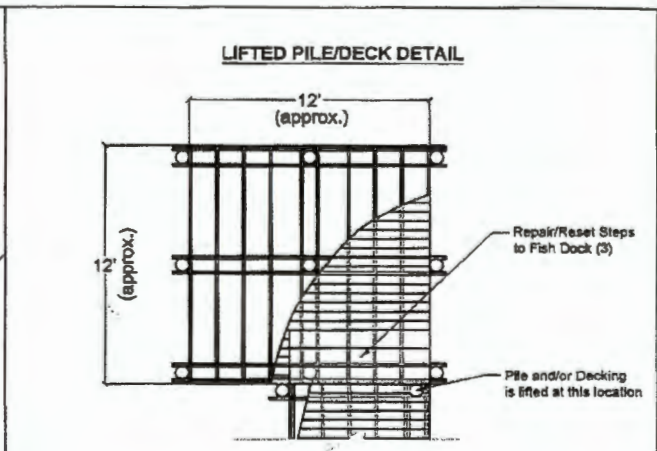
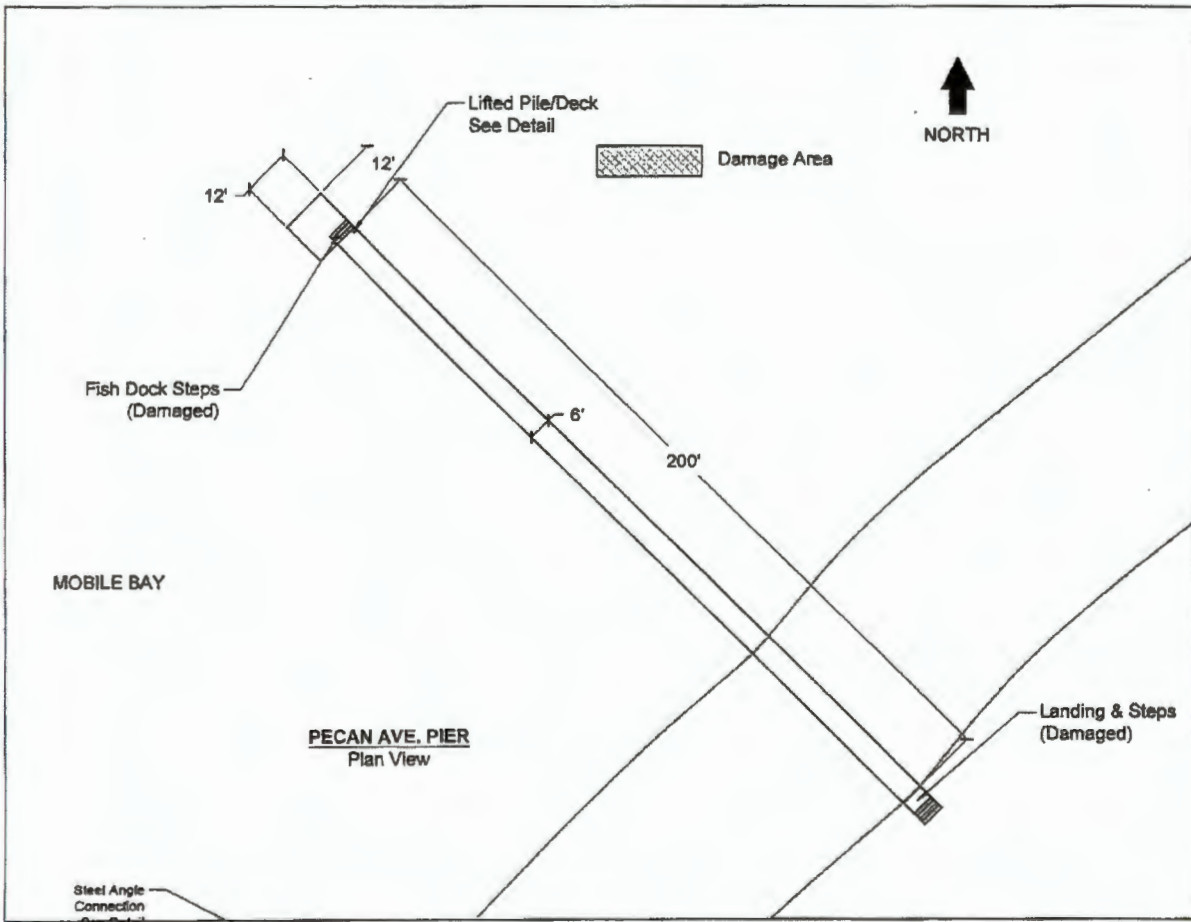

- PILE/DECK REPAIR NOTES:**
- The piling and/or deck is lifted at the northwest end of the wooden pier. This pile protrudes through the deck and support the pier light fixture.
  - It is the intent of this repair to reset the pile to level pier without damaging intact sub and superstructure.
  - Contractor shall have latitude on how to conduct the work:
    - Piles can be mechanically driven from shallow-draft barge on water.
    - Piles can be reset by jacking as long as turbidity control measures are employed.
  - Post pile resetting contractor shall tighten and refasten all loose hardware and fasteners.
  - All work proposed should match dimensions and geometric of existing structure(s). Any areas of conflict should be addressed with the Director of Public Works prior to work.
  - All new and repair work shall be conducted and completed without damage to the existing pier structures and the existing piles.

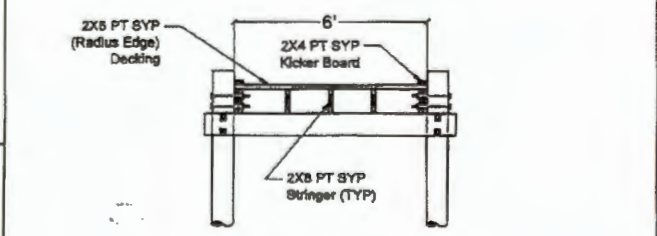

- NOTES:**
- All wood shall be No. 1, Pressure Treated (2.5 CCA), Southern Yellow Pine - Decking 2"x8" (Radius Edge); Stringers 2"x8"; Pile Caps (Beam) 2"x8" Rough Cut.
  - If new piles are required - Piling Penetration shall be the Greater of: 10' Penetration into ground or 1/3 total length of pile Contractor is to Determine the Length of Piling Needed To Meet This Requirement. For new piles with exposed tops - Top of Piling shall Be Sanded Smooth and Edges Rounded  $\frac{1}{2}$ ".
  - Decking and 2" dimensional railings shall be installed using #10 x 3.5-in Countersinking-Head Polymer-Coated Deck Screws - minimum 2 screws per stringer and/or connection point.
  - All through bolts fastening pile caps (beams) and stringers to piles shall be  $\frac{3}{4}$ "  $\phi$  hot dipped galvanized steel with 2  $\frac{1}{2}$ " x 2  $\frac{1}{2}$ " x  $\frac{1}{4}$ " hot dipped galvanized plate washer.
  - All quantities are approximate, the contractor shall visit site prior to bidding and field verify quantities and extents of damage.
  - All work proposed should match dimensions and geometric of existing structure(s). Any areas of conflict should be addressed with the Director of Public Works prior to work.

PECAN AVENUE PIER - PILE RESET & DECK LEVELING		
City of Fairhope	Dept. of Public Works	Drawn By: RDJ
Project #: 2021-PW 006		Scale: N.T.S.
Date: 01/12/21	Permit Dwg (01/12/21)	Sheet 4 of 5

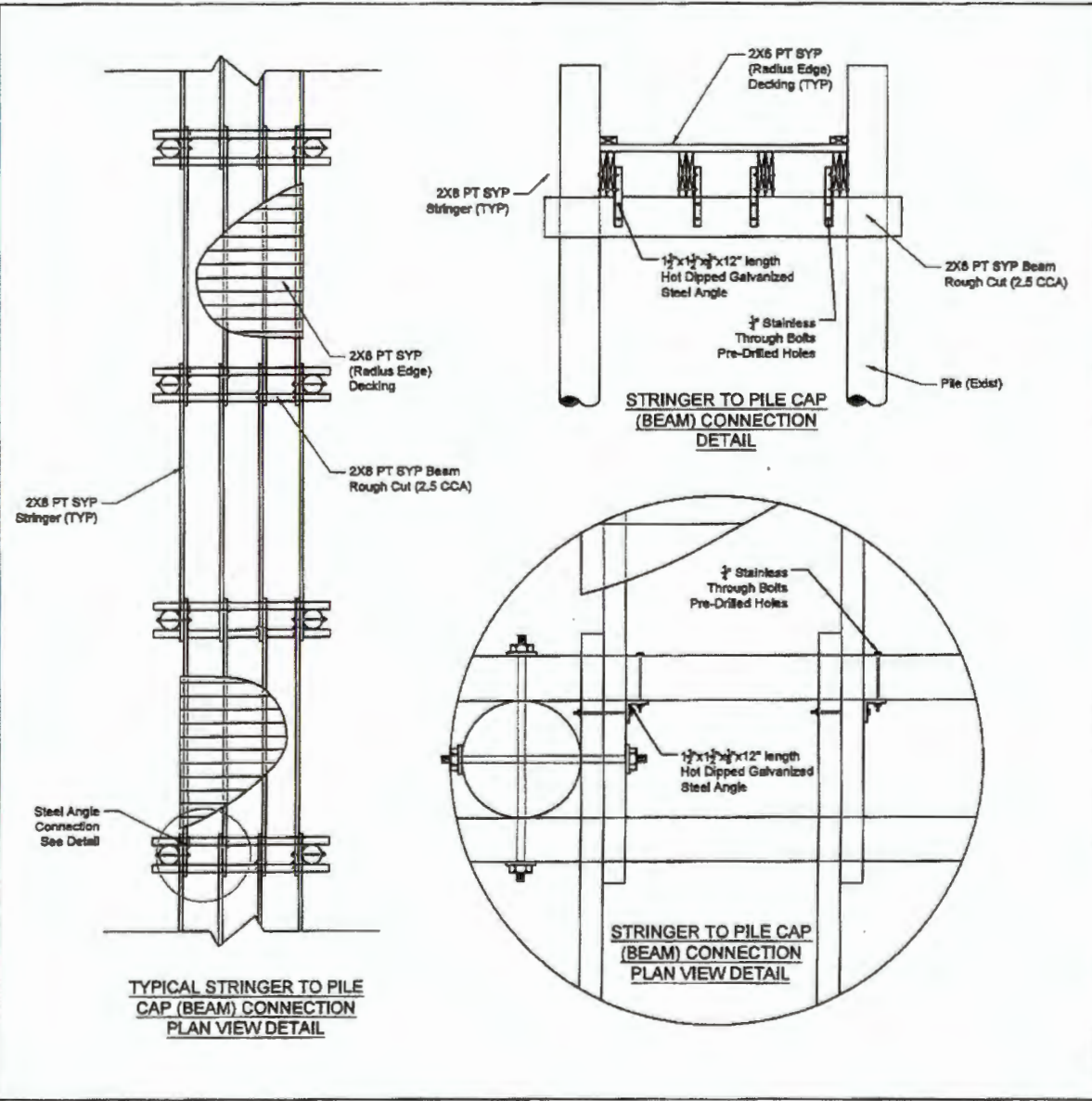

**GENERAL PROJECT NOTES**

1. This is a singular project consisting of work involving the repair and rebuilding of a city-owned piers described as:
  - 1.1. North Beach Park - North Pier
  - 1.2. North Beach Park - South Pier
2. Work includes, but is not limited to: replacement of wooden piles, repair and/or replacement of pile caps (beams), stringers, decking, railings, steps, fishing docks, covered piers and all other pier related infrastructure(s).
3. Note: Unit Quantities include subsidiary obligations of the repair work - bidding contractor should thoroughly review all quantities and the description of work product prior to bidding.
4. The Public Works Director will determine the priority and the order of work concerning the pier.
5. The removal and proper disposal of all construction and demolition (C&D) debris is the contractor's responsibility. The cost of such removal and disposal shall be a subsidiary obligation of the related works unit costs.
6. The contractor shall secure the site when workers are not present. The pier shall be barricaded and proper signage displayed at all times during construction. Pier shall not be opened to the General Public until inspected and all work is accepted by the owner.
7. Some work will involve field investigation and "design build" prior to repair. All proposed field modifications and "design build" shall be reviewed and approved by the Public Works Director prior to Contractor's initiation of work.
8. Plan Notes:
  - 8.1. All shown dimensions and areas are approximate - contractor should field verify prior to submission of bids
  - 8.2. Payment will be based on actual quantities of repair work completed by the contractor
  - 8.3. The Public Works Director shall decide the meaning and intent of any portion of the specifications and of any plans or drawings where the same may be found obscure or be in dispute.
  - 8.4. These plans are to be considered "suggestive" or "recommended" - field conditions may dictate alternative repair methodologies.
  - 8.5. All work proposed should match dimensions and geometric's of existing structure(s).
9. Questions or clarifications contact Richard D. Johnson, P.E. at (251) 929-0360 or richard.johnson@fairhopeal.gov

PIER REPAIR PROJECT - TYPICAL DETAILS		
City of Fairhope	Dept. of Public Works	Drawn By: RDJ
Project #: 2021-PWI 006		Scale: N.T.S.
Date: 11/06/2020	Permit Dwg (01/12/21)	Sheet 5 of 5

CERTIFICATION REGARDING LOBBYING

The undersigned certifies, to the best of his or her knowledge and belief, that:

(1) No Federal appropriated funds have been paid or will be paid, by or on behalf of the undersigned, to any person for influencing or attempting to influence an officer or employee of any agency, a Member of Congress, an officer or employee of Congress, or an employee of a Member of Congress in connection with the awarding of any Federal grant, the making of any Federal loan, the entering into of any cooperative agreement, and the extension, continuation, renewal, amendment or modification of any Federal contract, grant, loan, or cooperative agreement.

(2) If any funds other than Federal appropriated funds have been paid or will be paid to any person for influencing or attempting to influence an officer or employee of any agency, a Member of Congress, an officer or employee of Congress, or an employee of a Member of Congress in connection with this Federal contract, grant, loan, or cooperative agreement, the undersigned shall complete and submit Standard Form-LLL, "Disclosure of Lobbying Activities," in accordance with its instructions.

(3) The undersigned shall require that the language of this certification be included in the award documents of all sub-awards at all tiers (including subcontracts, sub-grants, and contracts under grants, loans, and cooperative agreements) and that all subrecipients shall certify and disclose accordingly.

This certification is a material representation of fact upon which reliance was placed when this transaction was made or entered into. Submission of this certification is a prerequisite for making or entering into this transaction imposed by section 1352, title 31, United States Code. Any person who fails to file the required certification shall be subject to a civil penalty of not less than \$10,000 and not more than \$100,000 for each such failure.

Organization:                                 ASPHALT SERVICES, INC.                                

Street address:                                 11045 OLD HIGHWAY 31                                

City, State, Zip:                                 SPANISH FORT, AL. 36527                                

CERTIFIED BY: (type or print)                                 GREG SMITH                                

TITLE                                 SENIOR PROJECT MANAGER                                

                                *Greg Smith*                                 (signature)                                 2/3/2021                                 (date)





City of Fairhope  
**BID RESPONSE FORM**

Multiple Piers - Repair Project - Hurricane Damage  
 Project No. 2021-PWI 006

NORTH BEACH PARK - NORTH PIER					
Item #	Description	Unit	Unit Quantity	Unit Price	Total Price
1.)	Pier Decking - 2"X6" No. 1, Radius Edge, Pressure Treated, Southern Yellow Pine (Pile Caps (Beams), Stringer Repair/Replacement and Specified Hardware Shall Be A Subsidiary Obligation of the Unit Price Quoted)	SF	720	40.25	28,980.00
2.)	Fish Dock - Approx. 16'X16' - 2"X6" No. 1, Radius Edge, Pressure Treated, Southern Yellow Pine (Pile Caps (Beams), Stringer Repair/Replacement, Handrails, Transition Steps and Specified Hardware Shall Be A Subsidiary Obligation of the Unit Price Quoted)	SF	256	40.25	10,304.00
3.)	Replacement Piles - 12" (Min.) Diameter - 2.5 CCA Treatment - Piling Penetration Shall be the Greater of: 10' Penetration into ground or 1/3 total length of pile Contractor is to Determine the Length of Piling Needed To Meet This Requirement	EACH	6	747.50	4,485.00
<b>Sub Project Total</b>					<b>\$ 43,769.00</b>

NORTH BEACH PARK - SOUTH PIER					
Item #	Description	Unit	Unit Quantity	Unit Price	Total Price
1.)	Resetting of Uplifted Piles - 12" (Min.) Diameter - The work can be accomplished by mechanical or hydraulic means - the tightening and refastening of all loose hardware and fasteners Shall Be a Subsidiary Obligation of the Unit Price Quoted	EACH	18	575.00	10,350.00
<b>Sub Project Total</b>					<b>\$ 10,350.00</b>

PECAN AVENUE PIER					
Item #	Description	Unit	Unit Quantity	Unit Price	Total Price
1.)	Resetting of Uplifted Pile, Leveling of Deck and Resetting/Repair of Steps - 12" (Min.) Diameter - The work can be accomplished by mechanical or hydraulic means - the tightening and refastening of all loose hardware and fasteners Shall Be a Subsidiary Obligation of the Unit Price Quoted	LS	1	6,000.00	6,000.00
<b>Sub Project Total</b>					<b>\$ 6,000.00</b>

<b>Total of All Sub Projects</b>					<b>\$ 60,119.00</b>
----------------------------------	--	--	--	--	---------------------

## BID BOND

**CONTRACTOR:**

(Name, legal status and address)

Asphalt Services, Inc.  
11045 Old Hwy. 31, Spanish Fort, AL 36527

**OWNER:**

(Name, legal status and address)

City of Fairhope  
P.O. Drawer 429, Fairhope, AL 36533

**BOND AMOUNT:**

5% Five Percent of Amount Bid

**PROJECT:**

(Name, location or address, and Project number, if any)

Wooden Pier Repairs, Project No. 2021-PWI 006

**SURETY:**

North American Specialty Insurance Company  
1450 American Lane, Suite 1100  
Schaumburg, IL 60173

This document has important legal consequences. Consultation with an attorney is encouraged with respect to its completion or modification.

Any singular reference to Contractor, Surety, Owner or other party shall be considered plural where applicable.

The Contractor and Surety are bound to the Owner in the amount set forth above, for the payment of which the Contractor and Surety bind themselves, their heirs, executors, administrators, successors and assigns, jointly and severally, as provided herein. The conditions of this Bond are such that if the Owner accepts the bid of the Contractor within the time specified in the bid documents, or within such time period as may be agreed to by the Owner and Contractor, and the Contractor either (1) enters into a contract with the Owner in accordance with the terms of such bid, and gives such bond or bonds as may be specified in the bidding or Contract Documents, with a surety admitted in the jurisdiction of the Project and otherwise acceptable to the Owner, for the faithful performance of such Contract and for the prompt payment of labor and material furnished in the prosecution thereof; or (2) pays to the Owner the difference, not to exceed the amount of this Bond, between the amount specified in said bid and such larger amount for which the Owner may in good faith contract with another party to perform the work covered by said bid, then this obligation shall be null and void, otherwise to remain in full force and effect. The Surety hereby waives any notice of an agreement between the Owner and Contractor to extend the time in which the Owner may accept the bid. Waiver of notice by the Surety shall not apply to any extension exceeding sixty (60) days in the aggregate beyond the time for acceptance of bids specified in the bid documents, and the Owner and Contractor shall obtain the Surety's consent for an extension beyond sixty (60) days.

If this Bond is issued in connection with a subcontractor's bid to a Contractor, the term Contractor in this Bond shall be deemed to be Subcontractor and the term Owner shall be deemed to be Contractor.

When this Bond has been furnished to comply with a statutory or other legal requirement in the location of the Project, any provision in this Bond conflicting with said statutory or legal requirement shall be deemed deleted herefrom and provision conforming to such statutory or other legal requirement shall be deemed incorporated herein. When so furnished, the intent is that this Bond shall be construed as a statutory bond and not as a common law bond.

Signed and sealed this 2nd day of February, 2021

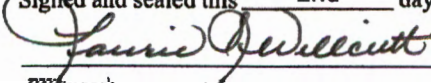
  
\_\_\_\_\_  
(Witness)

Asphalt Services, Inc.

(Principal)

By: 

(Title)

North American Specialty Insurance Company

(Surety)

By: 

(Title) Jeffrey M. Wilson, Attorney-in-Fact

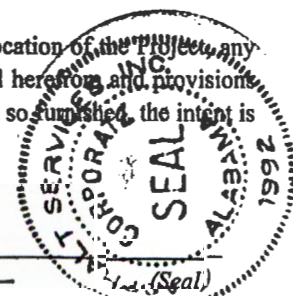

SWISS RE CORPORATE SOLUTIONS

NORTH AMERICAN SPECIALTY INSURANCE COMPANY
WASHINGTON INTERNATIONAL INSURANCE COMPANY
WESTPORT INSURANCE CORPORATION GENERAL POWER OF ATTORNEY

KNOW ALL MEN BY THESE PRESENTS, THAT North American Specialty Insurance Company, a corporation duly organized and existing under laws of the State of New Hampshire, and having its principal office in the City of Kansas City, Missouri and Washington International Insurance Company a corporation organized and existing under the laws of the State of New Hampshire and having its principal office in the City of Kansas City, Missouri, and Westport Insurance Corporation, organized under the laws of the State of Missouri, and having its principal office in the City of Kansas City, Missouri does hereby make, constitute and appoint:

MARK W. EDWARDS II, JEFFREY M. WILSON, WILLIAM M. SMITH, ROBERT R. FREEL, ALISA B. FERRIS and RICHARD H. MITCHELL

JOINTLY OR SEVERALLY

Its true and lawful Attorney(s)-in-Fact, to make, execute, seal and deliver, for and on its behalf and as its act and deed, bonds or other writings obligatory in the nature of a bond on behalf of each of said Companies, as surety, on contracts of suretyship as are or may be required or permitted by law, regulation, contract or otherwise, provided that no bond or undertaking or contract or suretyship executed under this authority shall exceed the amount of: ONE HUNDRED TWENTY FIVE MILLION (\$125,000,000.00) DOLLARS

This Power of Attorney is granted and is signed by facsimile under and by the authority of the following Resolutions adopted by the Boards of Directors of North American Specialty Insurance Company and Washington International Insurance Company at meetings duly called and held on March 24, 2000 and Westport Insurance Corporation by written consent of its Executive Committee dated July 18, 2011.

"RESOLVED, that any two of the President, any Senior Vice President, any Vice President, any Assistant Vice President, the Secretary or any Assistant Secretary be, and each or any of them hereby is authorized to execute a Power of Attorney qualifying the attorney named in the given Power of Attorney to execute on behalf of the Company bonds, undertakings and all contracts of surety, and that each or any of them hereby is authorized to attest to the execution of any such Power of Attorney and to attach therein the seal of the Company; and it is

FURTHER RESOLVED, that the signature of such officers and the seal of the Company may be affixed to any such Power of Attorney or to any certificate relating thereto by facsimile, and any such Power of Attorney or certificate bearing such facsimile signatures or facsimile seal shall be binding upon the Company when so affixed and in the future with regard to any bond, undertaking or contract of surety to which it is attached."



By Steven P. Anderson, Senior Vice President of Washington International Insurance Company & Senior Vice President of North American Specialty Insurance Company & Senior Vice President of Westport Insurance Corporation

By Mike A. Ito, Senior Vice President of Washington International Insurance Company & Senior Vice President of North American Specialty Insurance Company & Senior Vice President of Westport Insurance Corporation



IN WITNESS WHEREOF, North American Specialty Insurance Company, Washington International Insurance Company and Westport Insurance Corporation have caused their official seals to be hereunto affixed, and these presents to be signed by their authorized officers this 18th day of JULY, 20 19.

North American Specialty Insurance Company
Washington International Insurance Company
Westport Insurance Corporation

State of Illinois
County of Cook ss:

On this 18th day of JULY, 20 19, before me, a Notary Public personally appeared Steven P. Anderson, Senior Vice President of

Washington International Insurance Company and Senior Vice President of North American Specialty Insurance Company and Senior Vice President of Westport Insurance Corporation and Michel A. Ito, Senior Vice President of Washington International Insurance Company and Senior Vice President of North American Specialty Insurance Company and Senior Vice President of Westport Insurance Corporation, personally known to me, who being by me duly sworn, acknowledged that they signed the above Power of Attorney as officers of and acknowledged said instrument to be the voluntary act and deed of their respective companies.



M. Kenny, Notary Public

I, Jeffrey Goldberg, the duly elected Vice President and Assistant Secretary of North American Specialty Insurance Company, Washington International Insurance Company and Westport Insurance Corporation do hereby certify that the above and foregoing is a true and correct copy of a Power of Attorney given by said North American Specialty Insurance Company, Washington International Insurance Company and Westport Insurance Corporation which is still in full force and effect.

IN WITNESS WHEREOF, I have set my hand and placed the seals of the Companies this 2nd day of February, 20 21



Jeffrey Goldberg, Vice President & Assistant Secretary of Washington International Insurance Company & North American Specialty Insurance Company & Vice President & Assistant Secretary of Westport Insurance Corporation

STATE OF ALABAMA

BID LIMIT: U  
AMOUNT: UNLIMITED



LICENSE NO.: 22479  
TYPE: RENEWAL

State Licensing Board for General Contractors

THIS IS TO CERTIFY THAT

ASPHALT SERVICES INC  
SPANISH FORT, AL 36527

is hereby licensed a General Contractor in the State of Alabama and is authorized to perform the following type(s) of work:

BC: BUILDING CONSTRUCTION, EV-S: POL DISPENSING SYSTEM, H/RR: HEAVY AND RAILROAD, HS: HIGHWAYS AND STREETS, MU: MUNICIPAL AND UTILITY

until December 31, 2021 when this Certificate expires.

Witness our hands and seal of the Board, dated Montgomery, Ala.,

11th day of December, 2020

*Marc W. O'Quinn*

SECRETARY-TREASURER

*Alan W. Kelly*

CHAIRMAN

169856



# ALABAMA DEPARTMENT OF TRANSPORTATION

1409 Coliseum Boulevard, Montgomery, Alabama 36110  
Bureau of Office Engineer / Plans and Proposals Section  
Telephone: 334-242-6444 FAX: 334-264-7976  
www.dot.state.al.us



Kay Ivey  
Governor

John R. Cooper  
Transportation Director

October 21, 2020

Asphalt Services, Inc.  
11045 Old Highway 31  
Spanish Fort, AL 36527

# CONFIDENTIAL

To Whom It May Concern:

This is to certify that the above addressee is qualified under the rules and regulations of the Alabama Department of Transportation and Section 23-1-56, Code of Alabama 1975, to submit proposals for Highway and Bridge Construction, and which bids are to be taken by the Alabama Department of Transportation, subject to the following restrictions.

Your contractor Identification number is 01-071

The permissible amount of work under contract at any one time is: \$75,769,130

This certificate not valid after: 4/30/2021

This certificate limits the holder to the classification of work indicated below:

- Flexible Paving
- Grading
- Minor Drainage
- Bit. Hot Mix Structural & Surface Course

Alabama Secretary of State Certificate of Existence: Foreign corporations will not be awarded a federal aid project without having furnished this office a Secretary of State Certificate of Existence valid for a period covering the bid award date. Foreign corporations will not be issued a bidding proposal for any project exclusive of federal funding without having provided this office with a Secretary of State Certificate of Existence valid for a period covering the bid opening date.

Alabama General Contractors License: You will not be awarded a federal aid project without having obtained an Alabama General Contractors License that is valid for a period covering the award date. Your bid on any project exclusive of federal funding will be rejected if you do not hold a valid Alabama General Contractors License and provide evidence of such in your bid package.

Memorandum of Understanding: MOU concerning enrollment in the E-Verify program must be on file in this office before a project can be awarded.

Sincerely,

Clay P. McBrien, P.E.  
State Office Engineer

Certified by:

Bryan E. Nichols  
Assistant Bureau Chief



# E-Verify



Company ID Number: 489423

To be accepted as a participant in E-Verify, you should only sign the Employer's Section of the signature page. If you have any questions, contact E-Verify at 888-464-4218.

**Employer Asphalt Services, Inc.**

**Laurie S Willcutt**

Name (Please Type or Print)

Title

**Electronically Signed**

**01/13/2012**

Signature

Date

**Department of Homeland Security – Verification Division**

**USCIS Verification Division**

Name (Please Type or Print)

Title

**Electronically Signed**

**01/13/2012**

Signature

Date

## Information Required for the E-Verify Program

### Information relating to your Company:

Company Name:	Asphalt Services, Inc.
Company Facility Address:	11045 Old Highway 31 Spanish Fort, AL 36527
Company Alternate Address:	
County or Parish:	BALDWIN
Employer Identification Number:	831062122



Company ID Number: 489423

North American Industry Classification Systems Code:	237
Administrator:	
Number of Employees:	20 to 99
Number of Sites Verified for:	1
Are you verifying for more than 1 site? If yes, please provide the number of sites verified for in each State:	
<ul style="list-style-type: none"><li>• ALABAMA 1 site(s)</li></ul>	

Information relating to the Program Administrator(s) for your Company on policy questions or operational problems:

Name:	Gregory T Smith	Fax Number:	(251) 621 - 9393
Telephone Number:	(251) 621 - 9325		
E-mail Address:	gsi@asi-gc.com		
Name:	Laurie S Willcutt	Fax Number:	(251) 621 - 9393
Telephone Number:	(251) 621 - 9325		
E-mail Address:	lsi@asi-gc.com		

**INSURANCE REQUIREMENTS**

**4.0 INSURANCE REQUIREMENTS**

Awarded Contractor, at its sole expense, shall obtain and maintain in full force the following insurance to protect the Contractor and the City of Fairhope at limits and coverages specified herein. The City of Fairhope will be listed as an additional insured under the Contractor's General Liability insurance and automobile liability insurance policies, and all other applicable policies and certificates of insurance. These limits and coverages specified are the minimum to be maintained and are not intended to represent the correct insurance needed to fully and adequately protect the awarded Bidder.

**4.01** All insurance will be provided by insurers by admitted carriers in the State of Alabama, shall have a minimum A.M. Best rating of A-VII and must be acceptable to the CITY. Self-insured plans and/or group funds not having an A.M. Best rating must be submitted to the CITY for prior approval.

**4.02 NO WORK IS TO BE PERFORMED UNTIL PROOF OF COMPLIANCE WITH THE INSURANCE REQUIREMENTS HAS BEEN RECEIVED BY THE CITY.**

**4.03 Worker's Compensation and Employer's Liability**

Part One: Statutory Benefits as required by the State of Alabama		
Part Two: Employer's Liability	\$1,000,000	each accident
	\$1,000,000	each employee
	\$1,000,000	Policy Limit

**4.04 U.S. Longshoreman & Harbor Workers Act (USL&H)**

Required if contract involves work near a navigable waterway that may be subject to the USL&H law.

**4.05 Maritime Endorsement (Jones Act)**

Endorsement required if contract involves the use of a Vessel. Or include coverage for "Master or Member or Crew" under "Protection and Indemnity" coverage (P&I) unless crew is covered under Workers Compensation.

Bodily injury by accident	\$1,000,000	each accident
Bodily injury by disease	\$1,000,000	aggregate

**4.06 Commercial General Liability**

Coverage on an Occurrence from with a combined single limit of (Bodily Injury and Property Damage combined as follows:

Each occurrence	\$1,000,000
Personal and Advertising Injury	\$1,000,000
Products/Completed Operation Aggregate	\$2,000,000
General Aggregate	\$2,000,000

Coverage to include:

- Premises and operations
- Personal injury and Advertising Injury
- Products/completed operations
- Independent Contractors
- Blanket Contractual Liability
- Explosion, Collapse and Underground hazards
- Broad Form Property Damage
- Railroad Protective Liability Insurance if work involves construction, demolition, or maintenance operations on or within 50 feet of a railroad.

**4.07 Automobile Liability**

Covering all owned, non-owned and hired vehicles with a limit of no less than \$1,000,000 combined single limit of Bodily injury and property damage per occurrence.

**4.08 Certificates of Insurance**

A Certificate of Insurance evidencing the above minimum requirements must be provided to and accepted by the CITY PRIOR to commencement of any work on the contract. Each policy shall be endorsed to provide ten (10) days written notice of cancellation to the CITY.

- 4.08.1** The Contractor shall require certificates of insurance from sub-Contractors. Sub-Contractors will carry limits of insurance equal to or greater than those carried by the Contractor. These certificates shall evidence waivers of subrogation in favor of the Contractor and the CITY, and shall be made available to the CITY upon request.

# **END OF PROPOSAL**



## **ASPHALT SERVICES, INC.**

11045 OLD HIGHWAY 31  
SPANISH FORT, AL. 36527

PHONE: (251) 621-9325

Fax: (251) 621-9393

Company Email: [asi@asi-gc.com](mailto:asi@asi-gc.com)

### **SENIOR PROJECT MANAGER:**

**Greg Smith**

(251) 689-8656

[gsmith@asi-gc.com](mailto:gsmith@asi-gc.com)

STATE OF ALABAMA  
**GC License Number: 22479**  
**Authorized Scopes of Work:**  
**BC; EV-S; H/RR; HS and MU**

RESOLUTION NO. \_\_\_\_\_

**BE IT RESOLVED BY THE GOVERNING BODY OF THE CITY OF FAIRHOPE, ALABAMA**, as follows:

[1] That the City of Fairhope has voted to purchase a 2021 Dodge Ram 2500 3/4 Ton Crew Cab 4x4 Pickup Truck for the Gas Department; and the type of vehicle needed is on the Alabama State Department of Purchasing bid list and therefore does not have to be let out for bid; and

[2] The following is the Alabama State Department of Purchasing contract information:

Bid Number: T191

2021 Dodge Ram 2500 3/4 Ton Crew Cab **Cost is \$28,208.30**

Adopted on this 22nd day of February, 2021

\_\_\_\_\_  
Jack Burrell, Council President

Attest:

\_\_\_\_\_  
Lisa A. Hanks, MMC  
City Clerk

City of Fairhope  
Project Funding Request

Issuing Date: 2/10/2021

Please return this Routing Sheet to Treasurer by: ASAP

Project Name: Procurement of (1) 2021 Ram 2500 3/4 ton crew cab 4x4 pickup truck

Project Location: Gas Department

Presented to City Council: 2/22/2021

Funding Request Sponsor: Terry Holman, Gas Superintendent  
Sherry Sullivan, Mayor

Resolution #: FEB 10 '21 PM 3:30  
Approved \_\_\_\_\_  
Changed \_\_\_\_\_  
Rejected \_\_\_\_\_

Project Cash Requirement Requested:  
Cost: \$ 28,208.30

Vendor: Stivers Ford Chrysler Dodge Jeep Ram of Prtville, AL

Project Engineer: n/a

Order Date: n/a Lead Time: n/a

Department Funding This Project

General  **Gas**  Electric  Water  Sewer  Gas Tax  Cap Project  Impact  Health  Fed Grant

Department of General Fund Providing the Funding

Admin-10  Bldg-13  Police-15  Fire-20  ECD-24  Rec-25  Civic-26  Street-35  Sanitation-40   
 Fac Maint-45  Golf-50  Golf Grounds-55  Museum-70  Debt Service-85  Marina-34  Plan/Zone

Project will be: Expensed  Capitalized XXX  Inventoried

Funding Source: Operating Expenses  Budgeted Capital XXX  Unfunded

Expense Code: 002-16030  
G/L Acct Name: Capital Purchases V&E

Project Budgeted: \$ 40,000.00  
Balance Sheet Item Included in projected cash flow

Over (Under) budget amount: \$ (11,791.70)

Comments:

Grant: \_\_\_\_\_ Federal - not to exceed amount  
\_\_\_\_\_ State  
\_\_\_\_\_ City  
\$0.00 Local

Bond: \_\_\_\_\_ Title \_\_\_\_\_ Year \_\_\_\_\_  
Loan: \_\_\_\_\_ Title \_\_\_\_\_ Year \_\_\_\_\_

Capital Lease: \_\_\_\_\_ - Payment \_\_\_\_\_ Term \_\_\_\_\_

City Council Prior Approval/Date? \_\_\_\_\_

Finance Manager: Jill Cabaniss, MBA City Treasurer: Kim Creech Mayor: Sherry Sullivan

Purchasing Memo Date: 2/2/2021 Purchasing Memo Date: 2/2/2021 Delivered To Date: 2/10/2021

Request Approved Date: 2/10/2021 Request Approved Date: 2/10/2021 Approved Date: \_\_\_\_\_

Signatures: Jill Cabaniss, MBA Kim Creech Mayor Sherry Sullivan



**MEMO**

To: **Kimberly Creech, Treasurer**  
From: *Delores Brandt*  
**Delores A Brandt, Purchasing Manager**

Sherry Sullivan  
Mayor

Date: **February 2, 2021**

*Council Members:*  
Kevin G. Boone  
Robert A. Brown  
Jack Burrell, ACO  
Jimmy Conyers  
Corey Martin

Re: **Greensheet and City Council Approval for procurement of budgeted, over \$10,000, request for ONE (1) 2021—RAM 2500 ¾ Ton Crew Cab 4x4 Pickup for the Gas Department**

Lisa A. Hanks, MMC  
City Clerk

The Gas Department Superintendent, Terry Holman, and the Superintendent of Utilities, Mayor Sherry Sullivan, are requesting procurement of **ONE (1) 2021-- RAM 2500 ¾ Ton Crew Cab 4x4 Pickup** for the Gas Department . The proposed budgeted amount is \$40,000. The best pricing is from the **State of Alabama Contract T191 #MA999 210000000080 Model**

The estimated of **ONE (1) RAM 2500 ¾ Ton Crew Cab 4x4 Pickup** which does not include delivery, plus required options, is **TWENTY-EIGHT THOUSAND TWO HUNDRED EIGHT DOLLARS AND THIRTY CENTS (\$28,208.30)**.

The State contract vendor is **Stivers Ford Chrysler Dodge Jeep RAM** of Prattville, AL

**NOTES:**

See Attached Vendor CUT-SHEET printout for details.  
Delivery/pickup Approximately 8-12 weeks ARO

161 North Section  
Street PO Drawer 429  
Fairhope, Alabama  
36533

**Please compose a greensheet and place on the next available City Council Agenda this request to approve this budgeted procurement for one (1) 2021-- RAM 2500 ¾ Ton Crew Cab 4x4 Pickup truck from Stivers Ford Chrysler Dodge Jeep RAM of Prattville, AL through the State of Alabama Bid T191 for \$28,208.30**

251-928-2136

251-928-6776 Fax  
[www.fairhopeal.gov](http://www.fairhopeal.gov)

CC file, Terry Holman, Sherry Sullivan, Tim Bung



# CITY OF FAIRHOPE PURCHASING DEPARTMENT REQUEST FORM

Name: Terry Holman

Date: 2/2/2021

Department: Gas

## ITEM OR SERVICE INFORMATION

1. What item or service do you need to purchase? 2021 Ram 2500 Crew Cab 4 x 4
2. What is the total cost of the item or service? \$27,936.80 + Delivery \$271.50 = \$28,208.30
3. Where will the item or service be physically located? Gas Department
4. What is the primary function of the item or service? Assistant Superintendent/Service Truck Job evaluation and inspection.
5. How many do you need? One
6. Item or Service Is:  New  Used  Replacement  Annual Request
7. When do you anticipate implementation? Upon delivery of approx. 60 to 90 days.
8. Additional Information or Comments: This truck was postponed from 2020
9. Vendor Name: Stivers, Prattville CD JR
10. Vendor Number: #6472 MA 999 21 8000000080

## BUDGET INFORMATION

1. Is it budgeted?  Yes  No  Emergency Request
2. If budgeted, what is the budgeted amount? \$40,000
3. What is the Capital Project Name or Operating Budget Code: 50472 Vehicles & Equipment
4. Check any applicable boxes:  State Contract  ALDOT  Purchasing Group  
 Sole Source (Attach Sole Source Justification)

*Email completed form with quotes and other supporting documentation to [deedee.brandt@fairhopeal.gov](mailto:deedee.brandt@fairhopeal.gov) and [jennifer.bush@fairhopeal.gov](mailto:jennifer.bush@fairhopeal.gov).*



Quotation prepared by:

BUTCH ADKINS

*Butch Adkins*

This is a quotation on the goods named, subject to the conditions noted below: Describe any conditions pertaining to these prices and any additional terms of the agreement. You may want to include contingencies that will affect the quotation.

To accept this quotation, sign here and return: \_\_\_\_\_

**THANK YOU FOR YOUR BUSINESS!**



State of Alabama  
Department of Finance  
Division of Purchasing  
Master Agreement

New

**CONTRACT INFORMATION**

**MASTER AGREEMENT NUMBER:** MA 999 21000000080

**NOT TO EXCEED AMOUNT:**

Begin Date: 11/12/2020

Procurement Folder: 1155201

Expiration Date: 11/12/2021

Procurement Type: Master Agreement

Solicitation Number:

Replaces Award Document:

Award Date:

Replaced by Award Document:

Modification Date: 11/17/20

Version Number: 1

**CONTACT INFORMATION**

**REQUESTOR:**

Patrick Hemme

334-242-7173

Pat.Hemme@purchasing.alabama.gov

**ISSUER:**

Patrick Hemme

334-242-7173

Pat.Hemme@purchasing.alabama.gov

**BUYER:**

Patrick Hemme

334-242-7173

Pat.Hemme@purchasing.alabama.gov

**GENERAL DESCRIPTION**

MA - STATE OF ALABAMA VEHICLES

STATE OF ALABAMA VEHICLES

**Ship To:**

**Bill To:**

**REASON FOR MODIFICATION**

**VENDOR INFORMATION**

**Name /Address:**

VS000054430: Stivers Brothers Automotive of Alabama Inc  
DBA: Stivers Chrysler Dodge Jeep Ram  
2209 Cobbs Ford Road

Prattville AL 36066

**Contact:**

Butch Adkins  
334-613-5000  
ladkins@stiversonline.com

**COMMODITY / SERVICE INFORMATION**

Line	Quantity	UOM	Unit Price	Service Amount	Service From	Service To	Line Sub Total	Line Total
1	0	EA	\$20,490.880000	\$0.00			\$0.00	\$0.00

0720225 - TRUCK, PICKUP, FULL SIZE, EXTENDED CAB, 5 PASSENGER, GASOLIN  
 RAM 1500 1/2 TON EXTENDED CAB 2WD  
 1/2 TON EXTENDED CAB 2WD SHORT BED.  
 EQUIPPED WITH THE MINIMUM SPECIFICATIONS:  
 8-CYLINDER ENGINE  
 WHEELBASE: MINIMUM 140" - 148" MAXIMUM  
 4-WHEEL ANTI LOCK BRAKES  
 AUTOMATIC TRANSMISSION  
 BLUETOOTH, AC/HEAT, AM/FM RADIO  
 REAR VIEW CAMERA  
 CLASS IV TRAILER HITCH WITH 4 / 7 PIN CONNECTOR.  
 HD COOLING COMPONENTS  
 CRUISE CONTROL, TILT STEERING WHEEL, POWER WINDOWS, DOOR LOCKS, KEYLESS ENTRY.  
 ALL STANDARD FEATURES.

MAKE: RAM  
 MODEL: 1500 DS1L41

Line	Quantity	UOM	Unit Price	Service Amount	Service From	Service To	Line Sub Total	Line Total
2	0	EA	\$25,928.720000	\$0.00			\$0.00	\$0.00

0720225 - TRUCK, PICKUP, FULL SIZE, EXTENDED CAB, 5 PASSENGER, GASOLIN  
 RAM 2500 3/4 TON CREW CAB 2WD  
 3/4 TON CREW CAB 2WD STANDARD BED.  
 EQUIPPED WITH THE MINIMUM SPECIFICATIONS:  
 8-CYLINDER ENGINE  
 WHEELBASE: MINIMUM 147" - 160" MAXIMUM  
 4-WHEEL ANTI LOCK BRAKES  
 AUTOMATIC TRANSMISSION  
 BLUETOOTH, AC/HEAT, AM/FM RADIO  
 REAR VIEW CAMERA  
 CLASS IV TRAILER HITCH WITH 4 / 7 PIN CONNECTOR.  
 HD COOLING COMPONENTS  
 CRUISE CONTROL, TILT STEERING WHEEL, POWER WINDOWS, DOOR LOCKS, KEYLESS ENTRY.  
 ALL STANDARD FEATURES.

MAKE: RAM  
 MODEL: 2500 DJ2L81  
 CAN BE OPTIONED UP TO LONG BED AND DIESEL.

Line	Quantity	UOM	Unit Price	Service Amount	Service From	Service To	Line Sub Total	Line Total
3	0	EA	\$25,936.800000	\$0.00			\$0.00	\$0.00

0720225 - TRUCK, PICKUP, FULL SIZE, EXTENDED CAB, 5 PASSENGER, GASOLIN  
 RAM 2500 3/4 TON CREW CAB  
 4WD

**Final**

**COMMODITY / SERVICE INFORMATION**

3/4 TON CREW CAB 4WD STANDARD BED.  
 EQUIPPED WITH THE MINIMUM SPECIFICATIONS:  
 8-CYLINDER ENGINE  
 WHEELBASE: MINIMUM 147" - 160" MAXIMUM  
 4-WHEEL ANTI LOCK BRAKES  
 AUTOMATIC TRANSMISSION  
 BLUETOOTH, AC/HEAT, AM/FM RADIO  
 REAR VIEW CAMERA  
 CLASS IV TRAILER HITCH WITH 4 / 7 PIN CONNECTOR.  
 HD COOLING COMPONENTS  
 CRUISE CONTROL, TILT STEERING WHEEL, POWER WINDOWS, DOOR LOCKS, KEYLESS ENTRY.  
 ALL STANDARD FEATURES.

MAKE: RAM

MODEL: 2500 DJ7L91

CAN BE OPTIONED UP TO LONG BED AND DIESEL.

Line	Quantity	UOM	Unit Price	Service Amount	Service From	Service To	Line Sub Total	Line Total
4	0	EA	\$18,981.940000	\$0.00			\$0.00	\$0.00

0720221 - TRUCK, PICKUP, REGULAR CAB AND CHASSIS, GASOLINE OR DIESEL  
 RAM 1500 TRUCK, PICKUP, REGULAR CAB AND CHASSIS  
 1/2 TON REGULAR CAB 2WD SHORT BED.  
 EQUIPPED WITH THE MINIMUM SPECIFICATIONS:  
 6-CYLINDER ENGINE  
 WHEELBASE: MINIMUM 120"  
 4-WHEEL ANTI LOCK BRAKES  
 AUTOMATIC TRANSMISSION  
 BLUETOOTH, AC/HEAT, AM/FM RADIO  
 REAR VIEW CAMERA  
 CRUISE CONTROL, TILT STEERING WHEEL, POWER WINDOWS, DOOR LOCKS, KEYLESS ENTRY.  
 ALL STANDARD FEATURES.

**Final**

MAKE: RAM

MODEL: 1500 DS1L61

Line	Quantity	UOM	Unit Price	Service Amount	Service From	Service To	Line Sub Total	Line Total
5	0		\$0.000000	\$0.00			\$0.00	\$0.00

07100 - AUTOMOBILES, SCHOOL BUSES, SUVs, AND VANS, INCLUDING DIESEL,  
 OPTIONAL EQUIPMENT  
 OPTIONAL EQUIPMENT  
 TO BE INVOICED AT DEALER COST.

Line	Quantity	UOM	Unit Price	Service Amount	Service From	Service To	Line Sub Total	Line Total
6	0		\$0.000000	\$0.00			\$0.00	\$0.00

96286 - Transportation of Goods, Shipping and Handling, and Other Fr  
 VEHICLE DELIVERY  
 VEHICLE DELIVERY  
 PLEASE REFER TO SPECIFICATION SHEET FOR DETAILS.

All terms, conditions, and any amendments to solicitation are part of this contract as if fully reproduced herein .

Approved:

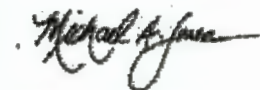

Purchasing Director

**RESOLUTION NO. \_\_\_\_\_**

**BE IT RESOLVED BY THE GOVERNING BODY OF THE CITY OF FAIRHOPE, ALABAMA**, as follows:

[1] That the City of Fairhope has voted to purchase a 2021 Dodge Ram 5500 Diesel Crew Cab and Chassis with dual rear wheels for the Gas Department; and the type of vehicle needed is on the Alabama State Department of Purchasing bid list and therefore does not have to be let out for bid; and

[2] The following is the Alabama State Department of Purchasing contract information:

Bid Number: T193-A

2021 Dodge Ram 5500 Diesel      **Cost is \$50,172.00**  
Crew Cab and Chassis

Adopted on this 22nd day of February, 2021

\_\_\_\_\_  
Jack Burrell, Council President

Attest:

\_\_\_\_\_  
Lisa A. Hanks, MMC  
City Clerk

City of Fairhope  
Project Funding Request

Issuing Date: 2/12/2021

Please return this Routing Sheet to Treasurer by: ASAP

Project Name: Procurement of one (1) 2021 5500 Ram Crew Cab and Chassis Diesel with dual rear wheels

02-15-21A08:25 RCVD  
FAH

Project Location: Gas Department

Presented to City Council: 2/22/2021

Funding Request Sponsor: Terry Holman, Gas Superintendent

Resolution # :  
Approved \_\_\_\_\_  
Changed \_\_\_\_\_  
Rejected \_\_\_\_\_

Project Cash Requirement Requested:  
Cost: \$ 50,172.00

Vendor: Tallassee Automotive, Inc.

Project Engineer: n/a

Order Date: n/a Lead Time: 8-10 weeks ARO

Department Funding This Project

General  Gas  Electric  Water  Sewer  Gas Tax  Cap Project  Impact  Health  Fed Grant

Department of General Fund Providing the Funding

Admin-10  Bldg-13  Police-15  Fire-20  ECD-24  Rec-25  Civic-26  Street-35  Sanitation-40   
Fac Maint-45  Golf-50  Golf Grounds-55  Museum-70  Debt Service-85  Marine-34  Plan/Zone

Project will be:

Expensed \_\_\_\_\_   
Capitalized XXX   
Inventoried XXX

Funding Source:

Operating Expenses \_\_\_\_\_   
Budgeted Capital XXX   
Unfunded \_\_\_\_\_

Expense Code: 002-16030  
G/L Acct Name: Capital Purchases V&E

Grant: \_\_\_\_\_ Federal - not to exceed amount  
\_\_\_\_\_ State  
\_\_\_\_\_ City  
\$0.00 Local

Project Budgeted: \$ 74,000.00  
Balance Sheet Item-  
Included in projected  
cash flow

Over (Under) budget amount: \$ (23,828.00)

Bond: \_\_\_\_\_ Title \_\_\_\_\_ Year \_\_\_\_\_  
Loan: \_\_\_\_\_ Title \_\_\_\_\_ Year \_\_\_\_\_

Comments:

GS 1895 is for the service body. Total budget for the truck and body are \$74k

Capital Lease: \_\_\_\_\_ - Payment \_\_\_\_\_ Term \_\_\_\_\_

City Council Prior Approval/Date? \_\_\_\_\_

Finance Manager

City Treasurer

Mayor

Purchasing Memo Date: 2/12/2021

Purchasing Memo Date: 2/12/2021

Delivered To Date: 2/12/2021

Request Approved Date: 2/12/2021

Request Approved Date: 2/12/2021

Approved Date: \_\_\_\_\_

Signatures:

Jill Cabaniss, MBA

Kim Creech

Mayor Sherry Sullivan





**MEMO**

To: Jill Cabaniss, Finance Manager  
Kimberly Creech, Treasurer

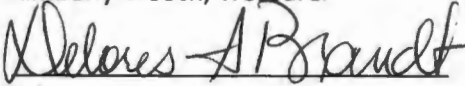
From:   
Delores A Brandt, Purchasing Manager

Date: February 12, 2021

Sherry Sullivan  
Mayor

*Council Members:*  
Kevin G. Boone  
Robert A. Brown  
Jack Burrell, ACOMO  
Jimmy Conyers  
Corey Martin

Lisa A. Hanks, MMC  
City Clerk

Kimberly Creech  
Treasurer

Re: **Greensheet --CC Approval procurement of proposed FY2021 budgeted, over \$10,000, request for ONE (1) 2021--5500 RAM CREW Cab & Chassis Diesel with dual rear wheels for the GAS Department**

The GAS Department Superintendent, Terry Holman requests procurement of ONE (1) 2021-- 5500 RAM CREW Cab & Chassis Diesel with dual rear wheels with utility body which is budgeted for \$74,000. The best pricing for the Crew Cab and Chassis is from the **State of Alabama Contract MA999 200000000116 T193-A with Tallassee Automotive Inc.** This budgeted Truck will be used for a 3rd Gas Dept Crew to run gas services and repair leaks. See attached Specifications.

**ONE (1) 2021-- 5500 RAM CREW Cab & Chassis Diesel with dual rear wheels which includes delivery.** The estimated cost is **FIFTY THOUSAND ONE HUNDRED SEVENTY-TWO DOLLARS (\$50,172.00)**. The State contract vendor is **Tallassee Automotive, Inc** contract #: **MA 999 200000000116 T193 A 2021 Model** (see attached

The Utility body will be ordered from another vendor on the State Contract.

NOTES: See Attached Vendor CUT-SHEET printout for details.  
Delivery/pickup Approximately 8-10 weeks ARO

**Please compose a greensheet and place on the next available City Council Agenda request to approve this budgeted procurement for one (1) 2021--5500 RAM CREW Cab & Chassis Diesel from Tallassee Automotive, Inc through State Contract T-193-A for \$50,172.00.**

161 North Section  
Street PO Drawer 429  
Fairhope, Alabama  
36533

251-928-2136

251-928-6776 Fax  
[www.fairhopeal.gov](http://www.fairhopeal.gov)

CC file, Terry Holman, Sherry Sullivan, Tim Bung; Clint Steadham

# CITY OF FAIRHOPE PURCHASING DEPARTMENT REQUEST FORM

**Name:** Terry Holman

**Date:** 2/11/2021

**Department:** Gas

## ITEM OR SERVICE INFORMATION

- 1. What item or service do you need to purchase?** Dodge Ram 5500 Crew Cab.
- 2. What is the total cost of the item or service?** \$50,172
- 3. Where will the item or service be physically located?** Gas Department
- 4. What is the primary function of the item or service?** To Run Gas services and Repair Leaks for a 3<sup>rd</sup> Crew.
- 5. How many do you need?** One
- 6. Item or Service Is:**  New  Used  Replacement  Annual Request
- 7. When do you anticipate implementation?** ASAP
- 8. Additional Information or Comments:** With Listed Upgrades.
- 9. Vendor Name:** Tallassee Automotive, Inc.
- 10. Vendor Number:** #6474.

## BUDGET INFORMATION

- 1. Is it budgeted?**  Yes  No  Emergency Request
- 2. If budgeted, what is the budgeted amount?** \$74,000.00
- 3. What is the Capital Project Name or Operating Budget Code:** 002-50470
- 4. Check any applicable boxes:**  State Contract  ALDOT  Purchasing Group  
 Sole Source (Attach Sole Source Justification)

*Email completed form with quotes and other supporting documentation to [deedee.brandt@fairhopeal.gov](mailto:deedee.brandt@fairhopeal.gov) and [jennifer.bush@fairhopeal.gov](mailto:jennifer.bush@fairhopeal.gov).*

TO : CITY OF FAIRHOPE UTILITIES  
ATTN : JASON LANGLEY

01 / 20 / 21'

FROM : TALLASSEE AUTOMOTIVE , INC.  
BRUCE BROWN @ 1-800-255-5650 or [bbrown@tallasseautomotive.com](mailto:bbrown@tallasseautomotive.com)

STATE OF ALABAMA – DIVISION OF PURCHASING 01 / 21 / 20'  
REF. VEHICLE CONTRACT # MA 999 20000000116 T 193 A 2020' MODEL YEAR

OPTIONS FOR RAM 5500 CREW CAB & CHASSIS LOT # 20  
EQUIPMENT INCLUDED : 60 " CA , DUAL REAR WHEELS , 18,000# GVWR , 6.4L V-8 GAS ENGINE , 6 SPD  
AUTOMATIC TRANSMISSION , AIR COND , TINTED GLASS w DK TINT REAR GLASS , AM/FM RADIO ,  
4 WHL DISC & ABS BRAKES , DUAL AIR BAGS , 180 AMP ALTERNATOR , TRAILER TOW MIRRORS . SPARE  
TIRE & WHEEL , LT225/70RX19.5G BSW A/S TIRES , ANTI-SPIN REAR DIFFERENTIAL , 52 GAL AFT AXLE  
FUEL TANK , ROOF CLEARANCE LAMPS , CRUISE CONTROL , TILT STEERING WHEEL . DAY TIME  
RUNNING LAMPS , U-CONNECT HANDS FREE PHONE CAPABILITY , P/WINDOWS-MIRRORS & LOCKS ,  
DASH MTD AUX SWITCHES , BLACK OVAL CAB STEPS , FUEL LINE KIT .

YOUR COST : \$34,532.00

“ ITEMS INDICATED ARE RECOMMENDED FOR YOUR APPLICATION “

UPGRADE TO 6.7L I-6 CUMMINS DIESEL ENGINE	#DSL \$8,997
UPGRADE TO 4WD MODEL	#4WD \$3,617
ELECTRIC SHIFT TRANSFER CASE	#DK3 \$286
TRACTION TREAD TIRES	#TTT \$243
SKID PLATE & TOW HOOKS	#XEF \$145
KEYLESS ENTRY	#GXM \$382
INTEGRATED ELECTRIC BRAKE CONTROL	#XHC \$359
115 v / 400 watt DASH MTD P/OUTLET	#JKV \$197
220 AMP ALTERNATOR	#BAJ \$236
CARGO LAMP BACK OF CAB	#LPE \$94
REAR VIEW CAMERA KIT shpd loose for bdy co mtng	#XAC \$495
UPGRADE TO 84 " CA FOR 11 ' BODY LENGTHS	#84CA \$289
DELIVERY TO YOUR LOCATION	#DLV \$300

TOTAL COST : \$50,172.00

COLOR : W7 WHITE TRIM : #TXX8 BLACK/DIESEL GRAY VINYL

;

RESOLUTION NO. \_\_\_\_\_

**BE IT RESOLVED BY THE GOVERNING BODY OF THE CITY OF FAIRHOPE, ALABAMA**, as follows:

[1] That the City of Fairhope has voted to purchase a 2021 Utility Body for Dodge Ram 5500 Diesel Crew Cab for the Gas Department; and the type of vehicle needed is on the Alabama State Department of Purchasing bid list and therefore does not have to be let out for bid; and

[2] The following is the Alabama State Department of Purchasing contract information:

State Contract No. MA999200000000122

2021 Utility Body for Dodge Ram 5500 Crew Cab	<b>Cost is \$22,371.00</b>
--	----------------------------

Adopted on this 22nd day of February, 2021

\_\_\_\_\_  
Jack Burrell, Council President

Attest:

\_\_\_\_\_  
Lisa A. Hanks, MMC  
City Clerk

City of Fairhope  
Project Funding Request

Issuing Date: 2/12/2021

Please return this Routing Sheet to Treasurer by: ASAP

Project Name: Procurement of one (1) 2021 Utility body for 5500 Ram Crew Cab truck

Project Location: Gas Department

Presented to City Council: 2/22/2021

Funding Request Sponsor: Terry Holman, Gas Superintendent

Resolution #: 02-15-21A08:25 RCVD  
Approved: [Signature]  
Changed: \_\_\_\_\_  
Rejected: \_\_\_\_\_

Project Cash Requirement Requested:  
Cost: \$ 22,371.00

Vendor: Tallassee Automotive, Inc.

Project Engineer: n/a

Order Date: n/a Lead Time: 8-10 weeks ARO

Department Funding This Project

General   Electric  Water  Sewer  Gas Tax  Cap Project  Impact  Health  Fed Grant

Department of General Fund Providing the Funding

Admin-10  Bldg-13  Police-15  Fire-20  ECD-24  Rec-25  Civic-26  Street-35  Sanitation-40   
 Fac Maint-45  Golf-50  Golf Grounds-55  Museum-70  Debt Service-85  Marina-34  Plan/Zone

Project will be: Expensed \_\_\_\_\_   
 Capitalized XXX   
 Inventoried XXX

Funding Source: Operating Expenses \_\_\_\_\_   
 Budgeted Capital XXX   
 Unfunded \_\_\_\_\_

Expense Code: 002-16030  
 G/L Acct Name: Capital Purchases V&E

Grant: \_\_\_\_\_ Federal - not to exceed amount  
 \_\_\_\_\_ State  
 \_\_\_\_\_ City  
\$0.00 Local

Project Budgeted: \$ 23,828.00 remaining after truck purchase  
 Balance Sheet Item- Included in projected cash flow

Over (Under) budget amount: \$ (1,457.00)

Comments: GS 1894 is for the truck itself. Total budget for the truck and body are \$74k

Bond: \_\_\_\_\_ Title \_\_\_\_\_ Year \_\_\_\_\_  
 Loan: \_\_\_\_\_ Title \_\_\_\_\_ Year \_\_\_\_\_

Capital Lease: \_\_\_\_\_ - Payment \_\_\_\_\_ Term \_\_\_\_\_

City Council Prior Approval/Date? \_\_\_\_\_

Finance Manager: [Signature] City Treasurer: [Signature] Mayor: [Signature]

Purchasing Memo Date: 2/12/2021 Purchasing Memo Date: 2/12/2021 Delivered To Date: 2/12/2021

Request Approved Date: 2/12/2021 Request Approved Date: 2/12/2021 Approved Date: \_\_\_\_\_

Signatures: [Signature] [Signature] [Signature]  
 Jill Cabaniss, MBA Kim Creech Mayor Sherry Sullivan



## MEMO

Sherry Sullivan  
Mayor

To: Jill Cabaniss, Finance Manager  
Kimberly Creech, Treasurer

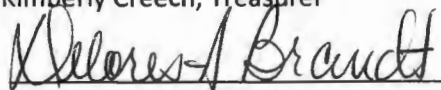
From:   
Delores A Brandt, Purchasing Manager

Date: February 12, 2021

*Council Members:*  
Kevin G. Boone  
Robert A. Brown  
Jack Burrell, ACMO  
Jimmy Conyers  
Corey Martin

Re: **Greensheet --CC Approval procurement of proposed FY2021 budgeted, over \$10,000, request for ONE (1) 2021-- Utility Body #6132D54 got RAM 5500 truck for the GAS Department**

Lisa A. Hanks, MMC  
City Clerk

The GAS Department Superintendent, Terry Holman requests procurement of ONE (1) 2021-- **One (1) 6132D54 Service Body for 84" CA DRW Chassis cab** for a 5500 RAM CREW Cab & Chassis Diesel with dual rear wheels. The truck and the body are budgeted for \$74,000. The best pricing is from the **State of Alabama contract MA 999 200000000122** and the vendor is **Truck Equipment Sales, Inc . The estimated quote is TWENTY-THREE THOUSAND THREE HUNDRED SEVENTY-ONE DOLLARS (\$22, 371.00)**. The budgeted Truck is for a 3rd Gas Dept Crew to run gas services and repair leaks. See attached Specifications.

Kimberly Creech  
Treasurer

NOTES: See Attached Vendor CUT-SHEET printout for details.  
Delivery/pickup Approximately 8-10 weeks ARO

**Please compose a greensheet and place on the next available City Council Agenda this request to approve budgeted procurement for one (1) 2021--84" Service body from Truck Equipment Sales, Inc., through State of Alabama Contract # MA 999 200000000122, in the estimated amount of \$22, 371.00**

161 North Section  
Street PO Drawer 429  
Fairhope, Alabama  
36533

CC file, Terry Holman , Tim Bung; Clint Steadham

251-928-2136

251-928-6776 Fax  
[www.fairhopeal.gov](http://www.fairhopeal.gov)

# CITY OF FAIRHOPE PURCHASING DEPARTMENT REQUEST FORM

**Name:** Terry Holman

**Date:** 2/12/2021

**Department:** Gas

## ITEM OR SERVICE INFORMATION

- 1. What item or service do you need to purchase?** Utility/Service Body #6132D54 for Dodge Ram 5500 Truck.
- 2. What is the total cost of the item or service?** \$22,371
- 3. Where will the item or service be physically located?** Gas Department
- 4. What is the primary function of the item or service?** Service work body for Gas Service Material.
- 5. How many do you need?** One
- 6. Item or Service Is:**  New  Used  Replacement  Annual Request
- 7. When do you anticipate implementation?** ASAP
- 8. Additional Information or Comments:** This Utility/Service Body will be installed on the new Dodge Ram 5500 Truck.
- 9. Vendor Name:** Truck Equipment Sales Inc.
- 10. Vendor Number:** 254

## BUDGET INFORMATION

- 1. Is it budgeted?**  Yes  No  Emergency Request
- 2. If budgeted, what is the budgeted amount?** \$74,000
- 3. What is the Capital Project Name or Operating Budget Code:** 002-50470
- 4. Check any applicable boxes:**  State Contract  ALDOT  Purchasing Group  
 Sole Source (Attach Sole Source Justification)

*Email completed form with quotes and other supporting documentation to [deedee.brandt@fairhopeal.gov](mailto:deedee.brandt@fairhopeal.gov) and [jennifer.bush@fairhopeal.gov](mailto:jennifer.bush@fairhopeal.gov).*

# TRUCK EQUIPMENT SALES, INC.

## Quote

Date	February 11, 2021
Valid Until	60 DAYS
Quote #	012621JH1231
Customer ID	

**Customer:**

City of Fairhope  
Terry Holman

**Quote/Project Description**

Utility Body for 84" CA Dodge Dual rear wheel chassis  
State Contract MA999200000000122  
Line 17 = \$6295.00 Line 22 = \$216.30 Line 23 = balance

Description	Line Total
6132D54 Service body for 84" CA DRW chassis cab. Includes Master locking compartments, 3 point rotary latches Work bumper with thru compartment, vise stand kit Knaphied proprietary STT light LED surface mount with built in strobe functionality Full factory paint including inside compartments LED marker lights 60" tall compartments street side 1st and 2nd vertical location 60" tall compartment curbside 1st and 2nd vertical location LED Compartment lights in all compartments wired to chassis switch on/off. 3 adjustable shelves each frt vertical compartments and one shelf in Left horizontal and SS and CS rear **Work bumper with 18,000lb hitch rating.	17,384.00
<b>Options:</b>	
Line-X complete bedfloor, compartment backs, tops (excl dng raised), bulkhead, and bmpr	1,300.00
Install front mount surface strobes and wire to switch with rear strobes	320.00
36" tall mechanic drawer set Street side 2nd vertical 1-7" drawer, 2-5" drawers, balance -3" drawers (each)	2,200.00
Install Four spot lights one on each corner of body	725.00
Pull out drawer installed in horizontal compartment (price each installs in either compartment)	442.00

**Special Notes and Instructions**

Once signed, please Fax, mail or e-mail it to the provided address.

Subtotal	
Discount	-
Sales Tax Rate	
Sales Tax	-
<b>Total</b>	<b>-</b>

Above information is not an invoice and only an estimate of services/goods described above.  
Payment and/or deposit will be collected prior to provision of services/goods described in this quote.

Please confirm your acceptance of this quote by signing this document

Signature	Print Name	Date
-----------	------------	------

**Thank you for your business!**

Should you have any enquiries concerning this quote, please contact Jimmy Hamrick on 251-666-8606



**RESOLUTION NO. \_\_\_\_\_**

**BE IT RESOLVED BY THE GOVERNING BODY OF THE CITY OF FAIRHOPE, ALABAMA, as follows:**

[1] That the City of Fairhope has voted to procure a 2021 Caterpillar 303.5 E2 CR-Canopy Mini Excavator with Power Angle for the Water and Sewer Departments; and the item is available for direct procurement through the Sourcewell Contract; and therefore, does not have to be let out for bid. This has been nationally bid through the OMNIA Partners' bid process. The total cost will be \$44,980.00.

Adopted on this 22nd day of February, 2021

\_\_\_\_\_  
Jack Burrell, Council President

Attest:

\_\_\_\_\_  
Lisa A. Hanks, MMC  
City Clerk

City of Fairhope  
Project Funding Request

Issuing Date: 2/11/2021

Please return this Routing Sheet to Treasurer by: ASAP

Project Name: Procurement of one (1) 2021 Caterpillar 303.5 E2 CR-Canopy Mini Excavator with power angle 02-15-21A03:25 RCVD

Project Location: Water and Sewer Departments

Presented to City Council: 2/22/2021 Resolution #:                     

Funding Request Sponsor: Jason Langley, Water & Sewer Superintendent Approved                     

Changed                     

Rejected                     

Project Cash Requirement Requested:  
Cost: \$ 44,980.00

Vendor: Thompson Tractor Company, Inc.

Project Engineer: n/a

Order Date: n/a Lead Time: n/a

**Department Funding This Project**

General  Gas  Electric  **Water**  Sewer  Gas Tax  Cap Project  Impact  Health  Fed Grant

**Department of General Fund Providing the Funding**

Admin-10  Bldg-13  Police-15  Fire-20  ECD-24  Rec-25  Civic-26  Street-35  Sanitation-40   
 Fac Maint-45  Golf-50  Golf Grounds-55  Museum-70  Debt Service-85  Marina-34  Plan/Zone

Project will be: Expensed  Capitalized XXX  Inventoried

Funding Source: Operating Expenses  Budgeted Capital XXX  Unfunded

Expense Code: 004-16030 Grant:                      Federal - not to exceed amount  
 G/L Acct Name: Capital Purchases V&E State                       
 City                       
\$0.00 Local

Project Budgeted: \$ 45,000.00  
 Balance Sheet Item- Included in projected cash flow                     



Over (Under) budget amount: \$ (20.00)

Comments:

Bond:                      Title                      Year                       
 Loan:                      Title                      Year                     

Capital Lease:                      - Payment                      Term                     

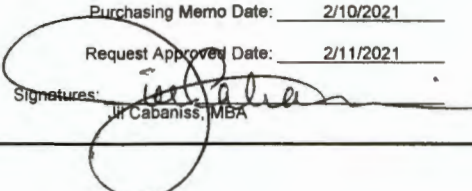
City Council Prior Approval/Date?                     

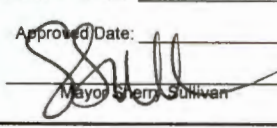
<b>Finance Manager</b>	<b>City Treasurer</b>	<b>Mayor</b>
Purchasing Memo Date: <u>2/10/2021</u>	Purchasing Memo Date: <u>2/10/2021</u>	Delivered To Date: <u>2/11/2021</u>
Request Approved Date: <u>2/11/2021</u>	Request Approved Date: <u>2/11/2021</u>	Approved Date: <u>                    </u>
Signatures: <u></u> J. Cabaniss, MBA	<u></u> Kim Creech	<u></u> Mayor Sherrill Sullivan



## MEMO

Karin Wilson  
Mayor

To: Kimberly Creech, Treasurer  
From: Delores A Brandt  
Delores A Brandt, Purchasing Manager

Date: February 10, 2021

*Council Members:*

Kevin G. Boone  
Robert A. Brown  
Jack Burrell, ACOMO  
Jimmy Conyers  
Jay Robinson

Lisa A. Hanks, MMC  
City Clerk

Kimberly Creech  
City Treasurer

Re: **Greensheet/City Council to approve acquisition of over \$10,000.00 budgeted 2021 Caterpillar 303.5 E2 CR-Canopy Mini Excavator with power angle through Sourcewell for the Water Dept**

The Water Department Superintendent, Jason Langley, has requested the acquisition of **one (1) 2021 Caterpillar 303.5 E2 CR-Canopy Mini Excavator with power angle** through the **SOURCEWELL Contract #032119 CAT**. This equipment is **budgeted** for \$45,000.00.

The cost of the **mini excavator** with 2 yr./2000 hr. Premier Full Machine warranty, freight and discounts (see attached quotes) is FORTY-FOUR THOUSAND NINE HUNDRED EIGHTY DOLLARS (\$44,980.00). The equipment will be obtained through **Thompson Tractor Company, Inc.** holding the contract with **SOURCEWELL Buying Group**.

The Water Department recommends the award be made to **Thompson Tractor Company, Inc.** of Spanish Fort, AL

**Please prepare a greensheet and place on the next City Council Agenda this request to Award request for 2021 303.5 E2 CR-Canopy Mini Excavator with power angle through SOURCEWELL Contract #032119 CAT, to Thompson Tractor Company, Inc. in the amount of \$49,980.00.**

*LL  
JC*

161 North Section  
Street PO Drawer 429  
Fairhope, Alabama  
36533

251-928-2136

251-928-6776 Fax  
[www.fairhopeal.gov](http://www.fairhopeal.gov)

Cc: file, Jason Langley, C Steadham

# CITY OF FAIRHOPE PURCHASING DEPARTMENT REQUEST FORM

**Name:** Jason S Langley

**Date:** 2/10/2021

**Department:** Water & Sewer

## ITEM OR SERVICE INFORMATION

- 1. What item or service do you need to purchase?** Cat 303.5 Excavator
- 2. What is the total cost of the item or service?** \$44,980.00
- 3. Where will the item or service be physically located?** 555 S. Section Street
- 4. What is the primary function of the item or service?** Water and sewer Crew
- 5. How many do you need?** One
- 6. Item or Service Is:**  New  Used  Replacement  Annual Request
- 7. When do you anticipate implementation?** Soon as possible
- 8. Additional Information or Comments:** Budgeted excavator to be utilized installing new services for Water and Sewer. Will also be available for other tasks as needed in the performance of operating and maintaining the Water and Sewer System.
- 9. Vendor Name:** Thompson Tractor Company
- 10. Vendor Number:** Click or tap here to enter text.

## BUDGET INFORMATION

- 1. Is it budgeted?**  Yes  No  Emergency Request
- 2. If budgeted, what is the budgeted amount?** \$45,000
- 3. What is the Capital Project Name or Budget Code:** 004-16500
- 4. Check any applicable boxes:**  State Contract  ALDOT  Purchasing Group  
 Sole Source (Attach Sole Source Justification)

*Email completed form with quotes and other supporting documentation to [deedee.brandt@fairhopeal.gov](mailto:deedee.brandt@fairhopeal.gov) and [jennifer.bush@fairhopeal.gov](mailto:jennifer.bush@fairhopeal.gov).*



**Thompson Tractor Company, Inc.**  
30950 State Highway 181  
Spanish Fort, AL 36527

*February 10, 2021*

*City of Fairhope  
555 South Section Street  
Fairhope, AL 36533*

*We are pleased to offer the following Caterpillar 303.5E2 for your review.*

**Caterpillar 303.5E2 CR-Canopy with Power Angle**

***Equipped with:***

- Rops Canopy***
- Cat C1.7-24.8hp -Gross***
- Long Stick***
- 70" Blade w/ Power Angle***
- 12" Rubber Belt Tracks***
- 18" Bucket and 24" Bucket***
- Mechanical Coupler***
- Caterpillar Hydraulic Thumb***

***Warranty: 2 year/2000hr Premier Full Machine***

<b><i>Caterpillar List Price</i></b>	<b>\$67,900.00</b>
<b><i>Sourcewell Contract #032119 CAT</i></b>	<b><u><del>(\$23,580.00)</del></u></b>
<b><i>Sales Price after discount</i></b>	<b>\$44,320.00</b>
<b><i>Freight Prep Delivery</i></b>	<b><u>\$660.00</u></b>
<b><i>City of Fairhope Price</i></b>	<b>\$44,980.00</b>

***We, at Thompson Tractor, are fully committed to helping you succeed with your projects. We appreciate the opportunity to earn your business, and we look forward to doing just that.***

***Sincerely,***

***Jimmy Mitchell  
Sales Representative  
Thompson Tractor Company***

**Alabama**

Birmingham Auburn/Opelika Mobile  
Anniston Dothan Montgomery  
Attalla Huntsville/Decatur Shelby County

**Florida**

Crestview Pensacola  
Marianna  
Panama City

**Georgia**

Albany Macon  
Atlanta Savannah  
Augusta

**RESOLUTION NO. \_\_\_\_\_**

**BE IT RESOLVED BY THE GOVERNING BODY OF THE CITY OF FAIRHOPE, ALABAMA, as follows:**

[1] That the City of Fairhope has voted to procure a 2021 Caterpillar 303.5 E2 CR-Canopy Mini Excavator with Power Angle through Sourcewell Contract and Econoline LP0721ITE Trailer through Omnia Partners Contract for the Gas Department; and the items are available for direct procurement through these Contracts. These items have been nationally bid through their bid process; and therefore, do not have to be let out for bid. The total cost will be \$49,996.00.

Adopted on this 22nd day of February, 2021

\_\_\_\_\_  
Jack Burrell, Council President

Attest:

\_\_\_\_\_  
Lisa A. Hanks, MMC  
City Clerk

City of Fairhope  
Project Funding Request

Issuing Date: 2/10/2021

Please return this Routing Sheet to Treasurer by: ASAP

Project Name: Procurement of Caterpillar 303.5 E2 CR-Canopy Mini Excavator and Econoline LP072ITE Trailer

Project Location: Gas Department

Presented to City Council: 2/22/2021

Funding Request Sponsor: Terry Holman, Gas Superintendent

Resolution # :  
Approved \_\_\_\_\_  
Changed \_\_\_\_\_  
Rejected \_\_\_\_\_

FEB 10 '21 PM 8:30

ZAN

Project Cash Requirement Requested:  
Cost: \$ 49,996.00

\$ -

Vendor: Thompson Tractor Company, Inc.

Project Engineer: n/a

Order Date: n/a Lead Time: n/a

Department Funding This Project

General  Gas  Electric  Water  Sewer  Gas Tax  Cap Project  Impact  Health  Fed Grant

Department of General Fund Providing the Funding

Admin-10  Bldg-13  Police-15  Fire-20  ECD-24  Rec-25  Civic-26  Street-35  Sanitation-40   
Fac Maint-45  Golf-50  Golf Grounds-55  Museum-70  Debt Service-85  Marina-34  Plan/Zone

Project will be:

Expensed \_\_\_\_\_   
Capitalized XXX   
Inventoried \_\_\_\_\_

Funding Source:

Operating Expenses \_\_\_\_\_   
Budgeted Capital XXX   
Unfunded \_\_\_\_\_

Expense Code: 002-16030  
G/L Acct Name: Capital Purchases V&E

Grant: \_\_\_\_\_ Federal - not to exceed amount  
\_\_\_\_\_ State  
\_\_\_\_\_ City  
\$0.00 Local

Project Budgeted: \$ 50,000.00  
Balance Sheet Item-  
Included in projected  
cash flow

Over (Under) budget amount: \$ (4.00)

Bond: \_\_\_\_\_ Title \_\_\_\_\_ Year \_\_\_\_\_  
Loan: \_\_\_\_\_ Title \_\_\_\_\_ Year \_\_\_\_\_

Comments:

Capital Lease: \_\_\_\_\_ - Payment \_\_\_\_\_ Term \_\_\_\_\_

City Council Prior Approval/Date? \_\_\_\_\_

Finance Manager

City Treasurer

Mayor

Purchasing Memo Date: 2/10/2021

Purchasing Memo Date: 2/10/2021

Delivered To Date: 2/10/2021

Request Approved Date: 2/10/2021

Request Approved Date: 2/10/2021

Approved Date: \_\_\_\_\_

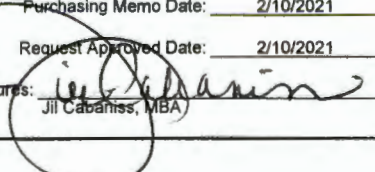
Signatures:   
Jill Cabaniss, MBA

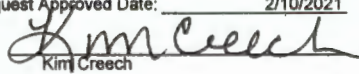
  
Kim Creech

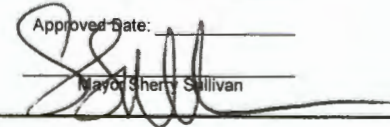
  
Mayor Sherry Sullivan



## MEMO

Karin Wilson  
Mayor

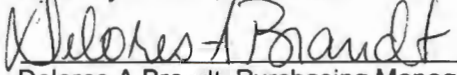
To: Kimberly Creech, Treasurer  
From:   
Delores A Brandt, Purchasing Manager

*Council Members:*  
Kevin G. Boone  
Robert A. Brown  
Jack Burrell, ACOMO  
Jimmy Conyers  
Jay Robinson

Date: February 10, 2021

Re: **Greensheet/City Council to approve acquisition of over \$10,000.00 budgeted 2021 Caterpillar 303.5 E2 CR-Canopy Mini Excavator with power angle through Sourcewell and Econoline LP072ITE Trailer through Onmi Partners for the Gas Dept**

Lisa A. Hanks, MMC  
City Clerk

The Gas Department Superintendent, Terry Holman, has requested the acquisition of **one (1) 2021 Caterpillar 303.5 E2 CR-Canopy Mini Excavator with power angle through SOURCEWELL Contract #032119 CAT, and Econoline LP072ITE Trailer through Omni Partners Contract #161534.** This equipment together is **budgeted** for \$50,000.00.

Kimberly Creech  
City Treasurer

The cost of the **mini excavator** with 2 yr./2000 hr. Premier Full Machine warranty, freight and discounts (see attached quotes) is FORTY-TWO THOUSAND TWO HUNDRED TEN DOLLARS (\$42,210.00). The Econoline LP072ITE Trailer with freight and discounts (see attached quotes) is SEVEN THOUSAND SEVEN HUNDRED EIGHTY-SIX DOLLARS (\$7,786.00). The equipment will be obtained through **Thompson Tractor Company, Inc.** holding the contracts with **SOURCEWELL** and **OMNIA PARTNERS Buying Group.**

The Gas Department recommends the award be made to **Thompson Tractor Company, Inc.** of Spanish Fort, AL, in the combined amount of **FORTY-NINE THOUSAND NINE HUNDRED NINETY-SIX DOLLARS (\$49,996.00).**

**Please prepare a greensheet and place on the next City Council Agenda this request to Award request for 2021 303.5 E2 CR-Canopy Mini Excavator with power angle through SOURCEWELL Contract #032119 CAT, and Econoline LP072ITE Trailer through Omni Partners Contract #161534 to Thompson Tractor Company, Inc. in the amount of \$49,996.00.**

161 North Section  
Street PO Drawer 429  
Fairhope, Alabama  
36533

251-928-2136

251-928-6776 Fax  
[www.fairhopeal.gov](http://www.fairhopeal.gov)

Cc: file, Terry Holman, C Steadham





**Thompson Tractor Company, Inc.**  
 30950 State Highway 181  
 Spanish Fort, AL 36527

*January 20, 2021*

*City of Fairhope  
 555 South Section Street  
 Fairhope, AL 36533*

*We are pleased to offer the following Econoline Trailer for your review.*

*Omnipartners Contract #161534*

*Econoline LP0721TE*

<i>Econoline List Price</i>	<i>\$9,405.00</i>
<i>OmniPartners Contract #161534 -12.4% Discount</i>	<i><u>(\$1,167.00)</u></i>
<i>Sales Price after discount</i>	<i>\$8,238.00</i>
<i>Freight Prep Delivery</i>	<i><u>\$150.00</u></i>
<i>Sales Price after nets.....</i>	<i>\$8,388.00</i>
<i>*TTCO Loyalty Discount in the amount of \$602.00</i>	
<i>City of Fairhope Price with Discount.....</i>	<i>\$7,786.00</i>

*We, at Thompson Tractor, are fully committed to helping you succeed with your projects. We appreciate the opportunity to earn your business, and we look forward to doing just that.*

*Sincerely,*

*Jimmy Mitchell  
 Sales Representative  
 Thompson Tractor Company*

**Alabama**

Birmingham Auburn/Opelika Mobile  
 Anniston Dothan Montgomery  
 Attalla Huntsville/Decatur Shelby County

**Florida**

Crestview Pensacola  
 Marianna  
 Panama City

**Georgia**

Albany Macon  
 Atlanta Savannah  
 Augusta



**Thompson Tractor Company, Inc.**  
30950 State Highway 181  
Spanish Fort, AL 36527

*February 9, 2021*

*City of Fairhope  
555 South Section Street  
Fairhope, AL 36533*

*We are pleased to offer the following Caterpillar 303.5E2 for your review.*

**Caterpillar 303.5E2 CR-Canopy with Power Angle**

***Equipped with:***

- Rops Canopy***
- Cat C1.7-24.8hp -Gross***
- Long Stick***
- 70" Blade w/ Power Angle***
- 12" Rubber Belt Tracks***
- 18" Bucket***
- Caterpillar Hydraulic Thumb***

***Warranty: 2 year/2000hr Premier Full Machine***

<b><i>Caterpillar List Price</i></b>	<b><i>\$60,400.00</i></b>
<b><i>Sourcewell Discount#032119 CAT</i></b>	<b><i><u>(\$18,810.00)</u></i></b>
<b><i>Sales Price after discount</i></b>	<b><i>\$41,590.00</i></b>
<b><i>Freight Prep Delivery</i></b>	<b><i><u>\$620.00</u></i></b>
<b><i>City of Fairhope Price</i></b>	<b><i>\$42,210.00</i></b>

***We, at Thompson Tractor, are fully committed to helping you succeed with your projects. We appreciate the opportunity to earn your business, and we look forward to doing just that.***

***Sincerely,***

***Jimmy Mitchell  
Sales Representative  
Thompson Tractor Company***

**Alabama**

Birmingham Auburn/Opelika Mobile  
Anniston Dothan Montgomery  
Attalla Huntsville/Decatur Shelby County

**Florida**

Crestview Pensacola  
Marianna  
Panama City

**Georgia**

Albany Macon  
Atlanta Savannah  
Augusta

# CITY OF FAIRHOPE PURCHASING DEPARTMENT REQUEST FORM

**Name:** Terry Holman

**Date:** 2/10/2021

**Department:** Gas

## ITEM OR SERVICE INFORMATION

- 1. What item or service do you need to purchase?** Caterpillar 303.5E2 Mini Excavator with Econoline tilt trailer.
- 2. What is the total cost of the item or service?** \$49,996.00
- 3. Where will the item or service be physically located?** Gas Department
- 4. What is the primary function of the item or service?** Installing Gas Services and repairing leaks.
- 5. How many do you need?** One
- 6. Item or Service Is:**  New  Used  Replacement  Annual Request
- 7. When do you anticipate implementation?** ASAP
- 8. Additional Information or Comments:** Caterpillar 303.5E2 Mini Excavator Sourcewell # 032119 and Econoline LP0721TE Tilt Trailer Omni Partners #161534.
- 9. Vendor Name:** Thompson Cat
- 10. Vendor Number:** 1117

## BUDGET INFORMATION

- 1. Is it budgeted?**  Yes  No  Emergency Request
- 2. If budgeted, what is the budgeted amount?** \$50,000
- 3. What is the Capital Project Name or Operating Budget Code:** 002-50470
- 4. Check any applicable boxes:**  State Contract  ALDOT  Purchasing Group  
 Sole Source (Attach Sole Source Justification)

*Email completed form with quotes and other supporting documentation to  
[deedee.brandt@fairhopeal.gov](mailto:deedee.brandt@fairhopeal.gov) and [jennifer.bush@fairhopeal.gov](mailto:jennifer.bush@fairhopeal.gov).*

**RESOLUTION NO. \_\_\_\_\_**

**BE IT RESOLVED BY THE GOVERNING BODY OF THE CITY OF FAIRHOPE, ALABAMA, as follows:**

[1] That the City of Fairhope has voted to procure a 2021 Petersen Lightning Loader Trash Truck with Dump Body for the Sanitation Department (Public Works); and the item is available for direct procurement through the Sourcewell Contract which has been nationally bid through their bid process; and therefore, does not have to be let out for bid. The total cost will be \$157,134.38.

Adopted on this 22nd day of February, 2021

\_\_\_\_\_  
Jack Burrell, Council President

Attest:

\_\_\_\_\_  
Lisa A. Hanks, MMC  
City Clerk

City of Fairhope  
Project Funding Request

Issuing Date: 2/11/2021

Please return this Routing Sheet to Treasurer by: ASAP

Project Name: Procurement of one (1) 2021 Peterson Lightning Loader trash truck and dump body

*[Handwritten Signature]*

Project Location: Sanitation Department

Presented to City Council: 2/22/2021

Funding Request Sponsor: Dale Linder, Supervisor-Sanitation/Recycling

Resolution # :  
Approved \_\_\_\_\_

Changed \_\_\_\_\_

Rejected \_\_\_\_\_

Project Cash Requirement Requested:  
Cost: \$ 157,134.38

Vendor: Petersen Industries, Inc.

Project Engineer: n/a

Order Date: n/a Lead Time: at least 6 months ARO

Department Funding This Project

General  Gas  Electric  Water  Sewer  Gas Tax  Cap Project  Impact  Health  Fed Grant

Department of General Fund Providing the Funding

Admin-10  Bldg-13  Police-15  Fire-20  ECD-24  Rec-25  Civic-26  Street-35  Sanitation-40   
Fac Maint-45  Golf-50  Golf Grounds-55  Museum-70  Debt Service-85  Marina-34  Plan/Zone

Project will be:

Expensed XXX   
Capitalized \_\_\_\_\_   
Inventoried \_\_\_\_\_

Funding Source:

Operating Expenses XXX   
Budgeted Capital \_\_\_\_\_   
Unfunded \_\_\_\_\_

Expense Code: 001400-50470  
G/L Acct Name: Capital Purchases V&E

Grant: \_\_\_\_\_ Federal - not to exceed amount  
\_\_\_\_\_ State  
\_\_\_\_\_ City  
\$0.00 Local

Project Budgeted: \$ 163,000.00  
Balance Sheet Item-  
Included in projected  
cash flow \_\_\_\_\_

Over (Under) budget amount: \$ (5,865.62)

Bond: \_\_\_\_\_ Title \_\_\_\_\_ Year \_\_\_\_\_  
Loan: \_\_\_\_\_ Title \_\_\_\_\_ Year \_\_\_\_\_

Comments:

Capital Lease: \_\_\_\_\_ - Payment \_\_\_\_\_ Term \_\_\_\_\_

City Council Prior Approval/Date? \_\_\_\_\_

Finance Manager

City Treasurer

Mayor

Purchasing Memo Date: 2/10/2021

Purchasing Memo Date: 2/10/2021

Delivered To Date: 2/11/2021

Request Approved Date: 2/11/2021

Request Approved Date: 2/11/2021

Approved Date: \_\_\_\_\_

Signatures: *[Signature]*  
M Cabaniss, MBA

*[Signature]*  
Kim Creech

*[Signature]*  
Mayor Sherry Sullivan



## MEMO

Sherry Sullivan  
Mayor

To: Kim Creech, City Treasurer  
From: Delores A Brandt  
Delores A Brandt, Purchasing Manager

Date: February 10, 2021

*Council Members*  
Kevin G. Boone  
Robert A. Brown  
Jack Burrell, ACOMO  
Jimmy Conyers  
Corey Martin

Re: **Request Green Sheet and City Council approval for procurement of one (1) budgeted 2021 Petersen Lightning Loader Trash truck and Dump Body for the Sanitation Department.**

Lisa A. Hanks, MMC  
City Clerk

The Sanitation Department has requested the procurement of one (1) Petersen Lightning Loader Trash Truck with dump body. Utilizing our access to national buying groups, quotations were sought for the unit (see attached).

Kimberly Creech  
City Treasurer

The Sanitation Department recommends acquiring the **2021 Petersen Lightning Loader Trash Truck and Dump body**. The total cost of the procurement with delivery is **ONE HUNDRED FIFTY-SEVEN THOUSAND ONE HUNDRED THIRTY FOUR DOLLARS AND THIRTY-EIGHT CENTS (\$157,134.38)**, through the **SOURCEWELL** Buying group contract # 041217-P11, from **Petersen Industries, Inc.** (see attached quotation) The local dealer handling the procurement is Sansom Equipment Company, of Mobile, AL.

Lead time is: At least 6 months, ARO.

**Please compose a greensheet and move forward for Council approval, this procurement request for one (1) 2021 Petersen Lightning Loader Trash Truck and Dump Body, for the quoted amount of \$157,134.38 through the SOURCEWELL Buying group Contract with Petersen Industries, Inc.**

161 North Section  
Street PO Drawer  
429  
Fairhope, Alabama  
36533

Cc, file, D. Linder, A. Bosarge

251-928-2136  
251-928-6776 Fax  
[www.fairhopeal.gov](http://www.fairhopeal.gov)

# CITY OF FAIRHOPE PURCHASING DEPARTMENT REQUEST FORM

**Name:** Dale Linder

**Date:** 2/10/2021

**Department:** Sanitation / Public Works

## ITEM OR SERVICE INFORMATION

- 1. What item or service do you need to purchase?** Peterson TL3 Lightning Loader Trash Truck
- 2. What is the total cost of the item or service?** \$157,134.38
- 3. Where will the item or service be physically located?** Public Works Yard
- 4. What is the primary function of the item or service?** Sanitation Trash Service
- 5. How many do you need?** One
- 6. Item or Service Is:**  New  Used  Replacement  Annual Request
- 7. When do you anticipate implementation?** Click or tap to enter a date.
- 8. Additional Information or Comments:** Vehicle Purchase for Sanitation Route Service At least 6 months lead time
- 9. Vendor Name:** Peterson Industries Inc.
- 10. Vendor Number:** 4003

## BUDGET INFORMATION

- 1. Is it budgeted?**  Yes  No  Emergency Request
- 2. If budgeted, what is the budgeted amount?** \$163,000.00
- 3. What is the Capital Project Name or Operating Budget Code:** 50470; Purchase Vehicles and Equipment
- 4. Check any applicable boxes:**  State Contract  ALDOT  Purchasing Group  
 Sole Source (Attach Sole Source Justification)

*Email completed form with quotes and other supporting documentation to  
[deedee.brandt@fairhopeal.gov](mailto:deedee.brandt@fairhopeal.gov) and [jennifer.bush@fairhopeal.gov](mailto:jennifer.bush@fairhopeal.gov).*

**Quote**



**Quote No**      **Quote Date**      **Page**  
 20210088      1/22/2021      1

Source Well No. 041217-P!!

**Bill To**

CITY OF FAIRHOPE  
 P.O. DRAWER 429  
 FAIRHOPE, AL 36533  
 US

**Ship to**

CITY OF FAIRHOPE  
 555 SECTION ST.  
 FAIRHOPE, AL 36532  
 US

**END USER:** Fairhope, City of (AL)

**Customer No**      **Slspsn**      **Payment terms**  
 2387      66      Net 30

**Loc**      **PPD/COL**      **Ship via**      **Ship Date**  
 LW           DRIVE AWAY      A.S.A.P.

**Delivery Date:** 60-90 Days After CHAS F

**Qty Ordered**      **UOM**      **Item No**      **Unit price**      **Disc**      **Extended price**

1.00      EA      LOADER  
 AS CONFIGURED BELOW      53,420.00      2.00      52,351.60

**Feature/Kit Components- LOADER**

1.00	EA	0.TL3	1.00		48,948.00
		MODEL TL3 BASE LOADER			
1.00	EA	03.11SAI	1.00		0.00
		HEAVY DUTY SWING MOTOR			
1.00	EA	01.11MQCA	1.00		3,092.00
		QUADSTICK MECH CONTROLS (UPGRADE)			
1.00	EA	01.24	1.00		342.00
		GRATING HEAT SHIELD (FOR DUAL CONTROLS ONLY)			
1.00	EA	07.10SB60	1.00		0.00
		STANDARD BUCKET 60"			
1.00	EA	10.04 BUWL	1.00		0.00
		BOOM-UP WARNING LIGHT/AUDIBLE ALARM			
1.00	EA	12.05 HG	1.00		335.00
		HOSE GUARDS- HEAD & VALVE BANK			
1.00	EA	8.41 TB TFM	1.00		703.00
		TOOL BOX, TRUCK FRAME MOUNTED UNDER BODY (ADD-ON)			
1.00	EA	12.36 HD	1.00		0.00
		HD CONTROL BOX THROTTLE ENGINE KILL & HORN			
1.00	EA	12.02 TP	1.00		0.00
		TANDEM PUMP IN LIEU OF SINGLE 18 GMP			
1.00	EA	11.02 LBPIO	1.00		0.00
		LOADER SINGLE COLOR PI ORANGE			

1.00      EA      8.0 DUMP BODY  
 AS CONFIGURED BELOW      23,344.00      2.00      22,877.12

**Feature/Kit Components- 8.0 DUMP BODY**

1.00	EA	8.11 1824-TBS	1.00		22,050.00
		MODEL TB-1824 TRASH BODY STANDARD 18FT X 24 CU. YD.			
1.00	EA	8.36 PISWLCD	1.00		923.00
		PI SELF-WINDING LOAD COVERING DEVICE (ADD-ON)			
1.00	EA	8.40 S-BD	1.00		0.00
		STANDARD BARN DOORS FOR BODY			
1.00	EA	8.47 WL-BW	1.00		0.00
		WIRE LOOM FOR BODY WIRING			
1.00	EA	10.09 LED	1.00		0.00
		LED TYPE BODY LIGHTS, 15 EA.			



**Quote**



**Quote No**      **Quote Date**      **Page**  
 20210088      1/22/2021      2

Source Well No. 041217-P11

**Bill To**

CITY OF FAIRHOPE  
 P.O. DRAWER 429  
 FAIRHOPE, AL 36533  
 US

**Ship to**

CITY OF FAIRHOPE  
 555 SECTION ST.  
 FAIRHOPE, AL 36532  
 US

**END USER:** Fairhope, City of (AL)

**Customer No**      **Slpsn**      **Payment terms**  
 2387      66      Net 30

**Loc**      **PPD/COL**      **Ship via**      **Ship Date**  
 LW           DRIVE AWAY      A.S.A.P.

**Delivery Date:** 60-90 Days After CHAS F

<b>Qty Ordered</b>	<b>UOM</b>	<b>Item No</b>	<b>Unit price</b>	<b>Disc</b>	<b>Extended price</b>
1.00	EA	10.10 LED FLASH AMBER LED FLASHERS IN REAR CORNER POST	1.00		371.00
1.00	EA	8.77ANSI ANSI Z245 PACKAGE	1.00		0.00
1.00	EA	11.02B BODY COLOR: BLACK	1.00		0.00
1.00	EA	CHASSIS-OTHER CHASSIS, FOR NEW LOADER 2021 Freightliner M2 106 Cummins L9 300 HP 860 LB/FT Torque Allison 3500 RDS Automatic Single rear axle, 33,000 GVWR	82,217.00	2.00	80,572.66

Dale Linder / 251-259-1500

\_\_\_\_\_  
 Signature

\_\_\_\_\_  
 Date

**SubTotal**      **155,801.38**  
**Delivery**      **1,333.00**  
**Tax**      **0.00**  
**Total Quote**      **157,134.38**

**RESOLUTION NO. \_\_\_\_\_**

**BE IT RESOLVED BY THE GOVERNING BODY OF THE CITY OF FAIRHOPE, ALABAMA**, as follows:

[1] That the City of Fairhope approves the procurement for Fairhope Fire Hall Roof damaged by Hurricane Sally (FEMA 4563). This Request for Quotes was sent to eight (8) contractors as well as multiple State agencies for MBE and DEB consideration. The initial request received no quotes, so the City solicited quotes a second time and received one quote; and awards the project to Roof Doctors of Alabama in the amount of \$10,500.00. An insurance claim has been filed; and once the claim is done, then FEMA claim will be submitted.

Adopted on this 22nd day of February, 2021

\_\_\_\_\_  
Jack Burrell, Council President

Attest:

\_\_\_\_\_  
Lisa A. Hanks, MMC  
City Clerk

City of Fairhope  
Project Funding Request

Issuing Date: 2/10/2021

Please return this Routing Sheet to Treasurer by: ASAP

FEB 10 '21 10:30

ZMA

Project Name: Repair of the Fairhope Fire Hall roof damaged by Hurricane Sally

Project Location: Municipal Pier Landing

Presented to City Council: 2/22/2021

Resolution #: Approved \_\_\_\_\_

Funding Request Sponsor: Richard Johnson, Public Works Director  
George Ladd, Supervisor Streets and Facilities Maintenance

Changed \_\_\_\_\_

Rejected \_\_\_\_\_

Project Cash Requirement Requested:  
Cost: \$ 10,500.00 FEMA reimbursement

\$ \_\_\_\_\_

Vendor: Roof Doctors of Alabama, Inc.

Project Engineer: n/a

Order Date: n/a

Lead Time: n/a

Department Funding This Project

General  Gas  Electric  Water  Sewer  Gas Tax  Cap Project  Impact  Health  Fed Grant

Department of General Fund Providing the Funding

Admin-10  Bldg-13  Police-15   Fire-20  ECD-24  Rec-25  Civic-26  Street-35  Sanitation-40   
Fac Maint-45  Golf-50  Golf Grounds-55  Museum-70  Debt Service-85  Marine-34  Plan/Zone

Project will be:

Expensed XXX   
Capitalized \_\_\_\_\_   
Inventoried \_\_\_\_\_

Funding Source:

Operating Expenses XXX   
Budgeted Capital \_\_\_\_\_   
Unfunded \_\_\_\_\_

Expense Code: 001200-60475  
G/L Acct Name: Capital Improvements

Grant: \_\_\_\_\_ Federal - not to exceed amount  
\_\_\_\_\_ State  
\_\_\_\_\_ City  
\$0.00 Local

Project Budgeted: \$ \_\_\_\_\_ - FEMA reimbursement 87.5%  
Balance Sheet Item-  
Included in projected  
cash flow \_\_\_\_\_

Over (Under) budget amount: \$ 10,500.00

Bond: \_\_\_\_\_ Title \_\_\_\_\_ Year \_\_\_\_\_  
Loan: \_\_\_\_\_ Title \_\_\_\_\_ Year \_\_\_\_\_

Comments:

Capital Lease: \_\_\_\_\_ - Payment \_\_\_\_\_ Term \_\_\_\_\_

City Council Prior Approval/Date? \_\_\_\_\_

Finance Manager

City Treasurer

Mayor

Purchasing Memo Date: 2/5/2021

Purchasing Memo Date: 2/5/2021

Delivered To Date: 2/10/2021

Request Approved Date: 2/10/2021

Request Approved Date: 2/10/2021

Approved Date: \_\_\_\_\_

Signatures: [Signature]  
M. Cabaniss, MBA

[Signature]  
Kim Creech

[Signature]  
Mayor Sherry Sullivan



## MEMO

To: Kimberly Creech, Treasurer

From: *Delores A Brandt*  
Delores A. Brandt, Purchasing Manager

Date: February 5, 2021

Sherry Sullivan  
Mayor

*Council Members:*

Kevin G. Boone  
Robert A. Brown  
Jack Burrell, ACOMO  
Jimmy Conyers  
Corey Martin

Lisa A. Hanks, MMC  
City Clerk

Kimberly Creech  
City Treasurer

**Re: Placement on City Council agenda to approve acquisition of repairs to the roof at the Fairhope Fire Hall located at the Municipal Pier Landing damaged by Hurricane Sally (FEMA 4563) for the Streets and Facilities Maintenance Department in Public Works**

The Public Works Director, Richard Johnson, and the Streets and Facilities Maintenance Supervisor, George Ladd, have need to repair the Fairhope Fire Hall roof damaged as a result of Hurricane Sally (FEMA 4563) on or about September 15, 2020.

A quote for Fairhope Fire Hall Roof Repairs was sent to eight (8) contractors as well as multiple state agencies for MBE and DBE consideration, was posted on the City website, and in the Public Utilities Building lobby satisfying both FEMA and Public Works procurement procedure requirements. The City did not receive any response to the request for quotes.

Since no quotes were received in the first request for response, the City of Fairhope solicited quotes a second time and received one response. The Director of Public Works recommends the award be made to **Roof Doctors of Alabama** in the amount of **TEN THOUSAND FIVE HUNDRED DOLLARS AND ZERO CENTS (\$10,500.00)**.

**Please prepare a greensheet and place on the next City Council Agenda this request to award the repair of the Fairhope Fire Hall roof damaged in Hurricane Sally (FEMA 4563) from ROOF DOCTORS OF ALABAMA in the amount of \$10,500.00.**

Cc: File, R. Johnson, G. Ladd

161 North Section St.  
PO Drawer 429  
Fairhope, AL 36533

251-928-2136 (p)  
251-928-6776 (f)  
www.fairhopeal.gov

**CITY OF FAIRHOPE TABULATION  
 QUOTE ROOF REPAIRS FAIRHOPE FIRE HALL  
 DEADLINE TO SUBMIT: January 12, 2021, 11:30 a.m.**

Vendor	Lump Sum Price
Porter Roofing Contractors	NO RESPONSE
Roof Doctors of Alabama	NO RESPONSE
Allstop Waterproofing	NO RESPONSE
Apex Contracting Alabama	NO RESPONSE
5 Star Roofer	NO RESPONSE
Metal Roofing Center	NO RESPONSE
Mid-Western Commercial Roofers	NO RESPONSE
Thomas Roofing	NO RESPONSE

**Recommendation: Solicit quotes in accordance with Public Works procurement procedures.**



Richard Johnson, Public Works Director

02/05/2021

Date

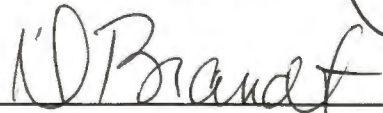

Delores A. Brandt, Purchasing Manager

2-5-21

Date

## Jennifer Bush

---

**From:** Jennifer Bush  
**Sent:** Wednesday, January 6, 2021 2:54 PM  
**To:** david@allstopwaterproofing.com; william@metalroofingcenter.com; roofdoctors.al@gmail.com; derek@thomasroofing.com; Zachary Bell; dan@5starroofer.com; daniel.smith.w@gmail.com; brian@fleminghsv.com  
**Cc:** Jennifer Bush  
**Subject:** City of Fairhope Roof Repairs  
**Attachments:** Quote Fire Hall Roof FEMA 4563.pdf; Quote Recreation Center Roof Repairs.pdf; Quote Founders Park Roof Repairs FEMA 4563.pdf

<b>Tracking:</b>	<b>Recipient</b>	<b>Delivery</b>
	david@allstopwaterproofing.com	
	william@metalroofingcenter.com	
	roofdoctors.al@gmail.com	
	derek@thomasroofing.com	
	Zachary Bell	
	dan@5starroofer.com	
	daniel.smith.w@gmail.com	
	brian@fleminghsv.com	
	Jennifer Bush	Delivered: 1/6/2021 2:54 PM

Please see attached Request for Quotes for various locations due to damage from Hurricane Sally (FEMA 4563). Deadline for submissions is listed within each quote.

Questions should be submitted in writing to [deedee.brandt@fairhopeal.gov](mailto:deedee.brandt@fairhopeal.gov).

## Jennifer Bush

Purchasing Administrative Assistant

555 S. Section Street  
Fairhope, AL 36532  
251-279-6231

## Jennifer Bush

---

**To:** Scott.Stewart@adeca.alabama.gov; PTAC@ua.edu; Danielle.Barnes@aamu.edu; Natoya.sterling@aamu.edu; dmills@uwa.edu; sstoudemire@uwa.edu; Mike.self@contractorcn.com; cm@contractorcn.com; meadowss@dot.state.al.us; cdrake@tuscaloosa.com; wrightz@dot.state.al.us

**Subject:** RE: City of Fairhope Roof Repairs

**Attachments:** Fuel Canopy Replacement Quote.pdf; Quote Recreation Center Roof Repairs.pdf; Quote Founders Park Roof Repairs FEMA 4563.pdf; Quote Fire Hall Roof FEMA 4563.pdf; Quote Public Works South Fence FEMA 4563.pdf

**From:** Jennifer Bush

**Sent:** Wednesday, January 6, 2021 9:18 AM

**To:** Scott.Stewart@adeca.alabama.gov; PTAC@ua.edu; Danielle.Barnes@aamu.edu; Natoya.sterling@aamu.edu; dmills@uwa.edu; sstoudemire@uwa.edu; Mike.self@contractorcn.com; cm@contractorcn.com; meadowss@dot.state.al.us; cdrake@tuscaloosa.com; wrightz@dot.state.al.us

**Subject:** City of Fairhope Roof Repairs

Please see attached Request for Quotes for various locations due to damage from Hurricane Sally (FEMA 4563). Deadline for submissions is listed within each quote.

Questions should be submitted in writing to [deedee.brandt@fairhopeal.gov](mailto:deedee.brandt@fairhopeal.gov).

## Jennifer Bush

Purchasing Administrative Assistant

555 S. Section Street  
Fairhope, AL 36532  
251-279-6231



805 River Route • Magnolia Springs, Alabama 36555 • (251) 233-8682 • (251) 943-8682 • Residential & Commercial Roofing

PROPOSAL SUBMITTED TO <b>George Ladd</b>		PHONE	DATE <b>2/3/2021</b>
STREET		JOB NAME <b>Fire Hall</b>	
CITY, STATE AND ZIP CODE		JOB LOCATION <b>Thompson Hall Rd Fairhope, AL 36532</b>	
ARCHITECT	DATE OF PLANS	JOB PHONE	

We hereby submit specifications and estimates for:

- Tear off existing shingles and felt
- Inspect decking and repair as needed @ \$60.00 per sheet
- Re-nail plywood per code
- Install Wind & Watershield
- Install new eve metal
- Install new shingles (GAF or Tamko)
- Install all flashing necessary (ridge vents, pipe flashing)
- Clean and haul away all job related debris
- Limited Lifetime warranty on material
- 2 year workmanship warranty

**We Propose** hereby to furnish material and labor, complete in accordance with above specifications, for  
MAKE CHECKS PAYABLE TO ROOF DOCTOR OF ALABAMA, INC.

the sum of: \_\_\_\_\_ dollars (\$ **\$10,500.00** ).

Payment to be made as follows: Upon Completion

All material is guaranteed to be as specified. All work is to be completed in a workmanlike manner according to standard practices. Any alteration or deviation from above specifications involving extra costs will be executed only upon written orders, and will become an extra charge over and above the estimate. All agreements contingent upon strikes, accidents or delays beyond our control. Owner to carry fire, tornado and other necessary insurance. Our workers are fully covered by Workman's Compensation Insurance.

Authorized Signature: Lance Carberry  
Note: This proposal may be withdrawn by us if not accepted within \_\_\_\_\_ days.

**Acceptance of Proposal** - The above prices, specifications and conditions are satisfactory and are hereby accepted. You are authorized to do the work as specified. Payment will be made as outlined above.

Date of Acceptance \_\_\_\_\_

Signature \_\_\_\_\_

Signature \_\_\_\_\_



**CITY OF FAIRHOPE  
REQUEST FOR QUOTATIONS  
COVER SHEET**

The following Request for Quotation is related to damages caused by Hurricane Sally (FEMA 4563) on or about September 15, 2020.

**Fire Hall Roof Repair**

**Date Issued:** January 5, 2021

**Deadline to Submit:** Tuesday, January 12, 2021, 11:30 a.m.

**Direct all Questions To:** Dee Dee Brandt, Purchasing Manager  
[DeeDee.Brandt@fairhopeal.gov](mailto:DeeDee.Brandt@fairhopeal.gov)

**Submitted Quotes Should Include:** Completed Quote Response form  
Anti-Lobbying Certification  
Other supporting documentation as requested

**Deliver Quotes To:** Public Works Building  
555 S. Section Street  
Fairhope, AL 36532

**Email Quotes To:** Dee Dee Brandt, Purchasing Manager  
[DeeDee.Brandt@fairhopeal.gov](mailto:DeeDee.Brandt@fairhopeal.gov)

For emailed quotes, please reference the Founders Park Roof Repairs in the subject line.

**1 Beach Drive – Fairhope Fire Hall**  
**Repair and Replacement of Asphalt Shingle Roof**  
**City of Fairhope Public Works Project No.**  
**Bid/Quote Response:**

**REPAIR and REPLACEMENT OF EXISTING ROOF BID/QUOTE:**

The City of Fairhope is requesting responses to repair and replace the composite asphalt shingle roof on the Fairhope Fire Hall Building located at 1 Beach Drive (Municipal Pier Landing), Fairhope, Alabama. During Hurricane Sally, September 16, 2020, hipped roof system was damaged beyond repair. The respondent shall submit a lump sum price to completely repair and replace the roof to current code standards. The lump sum price should include all material, equipment, tools, labor, and incidentals to deliver a complete "turnkey" replaced roof system.

**SCOPE OF WORK:**

Work shall include, but not be limited to the following:

- Remove Existing Shingles and Felt to Decking
- Inspect, Remove and Replace any Bad Decking as needed
- Re-nail decking per code (See Attached)
- Install Deck Tape on Plywood Laps per code (wind and watershed)
- Install New Underlayment per code (wind and watershed)
- Install New eve/valley metal Trim Package
- Install new GAF Timberline 30-year shingles (or equivalent) – owner to select color
- Install new Ridge Vent, Ridge Cap, Wall Flashings and Pipe (vent) Boots
- Clean, Haul and Dispose of all job-related debris
- Provide Limited Lifetime Warranty on Shingles
- Provide 2-year workmanship warranty
- This project is not located in the City of Fairhope Fire District

**CRITICAL TIMELINES:**

- 15-day Notice to Proceed Period
- 21 Calendar Days allowed for work (no exceptions for holidays)

**GENERAL NOTES:**

1. Contractor will be required to be Licensed, Bonded, and Insured. Documents will be required at time of bid/quote acceptance and issuance of purchase order.
2. Work must be completed 21 calendar days from the end of "Notice to Proceed" period.
3. Enclosed scope of work, descriptions, quantities, etc. are "good faith" estimates only. Prior

to submitting quotations contractor should field measure and verify all quantities.

4. Quotes will be treated and considered as "lump sum" bids for all described work.
5. Only one pay request will be accepted and processed upon final acceptance of work.
6. Job quoted are subject to the GENERAL CONDITIONS, SPECIAL PROVISIONS and SUPPLEMENTAL SPECIFICATIONS as attached.
7. Questions, inquiries and requests for clarification should be directed to Richard D. Johnson, PE; Director of Public Works: Phone - (251) 928-8003; or by Email [richard.johnson@fairhopeal.gov](mailto:richard.johnson@fairhopeal.gov)
8. Quotes must be received by Tuesday, January 12, 2020 at 11:00 a.m., at the Purchasing Department; 555 South Section Street; Fairhope, AL 36532 or via email at [deedee.brandt@fairhopeal.gov](mailto:deedee.brandt@fairhopeal.gov).

**New Asphalt Shingle Roof Repair  
and Replacement Lump Sum Bid:**

\$ \_\_\_\_\_

Contractor Name: \_\_\_\_\_

Address: \_\_\_\_\_

City: \_\_\_\_\_ State: \_\_\_\_\_ Zip: \_\_\_\_\_

Contact Name: \_\_\_\_\_ Phone: \_\_\_\_\_



Mobile Bay

### DR-AL-4563 PA PROJECT Location Map

— Road Centerlines

□ Parcels

Aerial Photo 2016

RGB

■ Red: Band\_1

■ Green: Band\_2

■ Blue: Band\_3



1 Beach Drive  
Roof Replacement Quote  
Fairhope Fire Hall

87°54'41.602"W, 30°31'26.612"N

South Beach Park

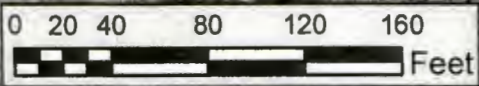

NORTH

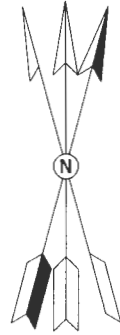

2475 Sq. Feet  
(Plan View)

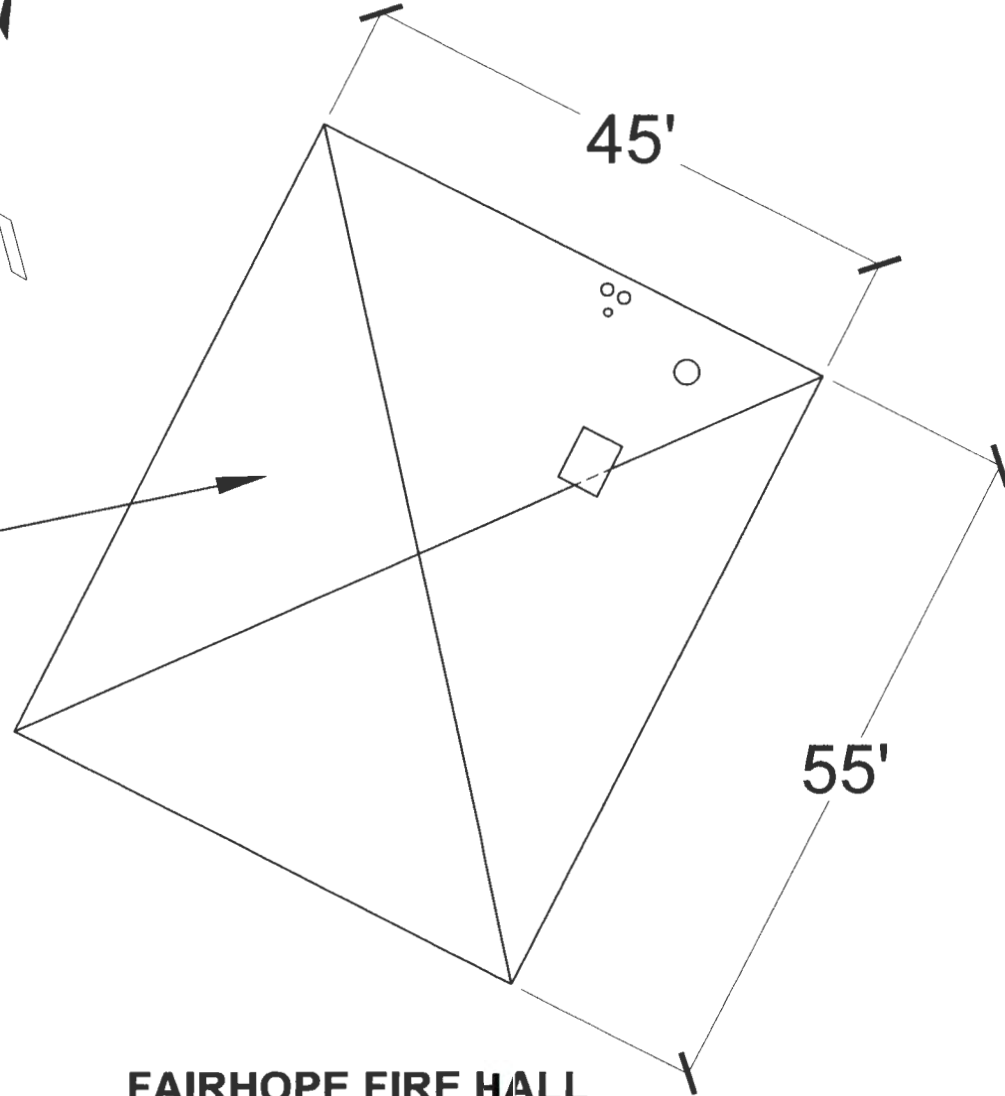

**FAIRHOPE FIRE HALL**  
**1 BEACH DRIVE**  
**PLAN VIEW**

CERTIFICATION REGARDING LOBBYING

The undersigned certifies, to the best of his or her knowledge and belief, that:

(1) No Federal appropriated funds have been paid or will be paid, by or on behalf of the undersigned, to any person for influencing or attempting to influence an officer or employee of any agency, a Member of Congress, an officer or employee of Congress, or an employee of a Member of Congress in connection with the awarding of any Federal grant, the making of any Federal loan, the entering into of any cooperative agreement, and the extension, continuation, renewal, amendment or modification of any Federal contract, grant, loan, or cooperative agreement.

(2) If any funds other than Federal appropriated funds have been paid or will be paid to any person for influencing or attempting to influence an officer or employee of any agency, a Member of Congress, an officer or employee of Congress, or an employee of a Member of Congress in connection with this Federal contract, grant, loan, or cooperative agreement, the undersigned shall complete and submit Standard Form-LLL, "Disclosure of Lobbying Activities," in accordance with its instructions.

(3) The undersigned shall require that the language of this certification be included in the award documents of all sub-awards at all tiers (including subcontracts, sub-grants, and contracts under grants, loans, and cooperative agreements) and that all subrecipients shall certify and disclose accordingly.

This certification is a material representation of fact upon which reliance was placed when this transaction was made or entered into. Submission of this certification is a prerequisite for making or entering into this transaction imposed by section 1352, title 31, United States Code. Any person who fails to file the required certification shall be subject to a civil penalty of not less than \$10,000 and not more than \$100,000 for each such failure.

Organization: \_\_\_\_\_

Street address: \_\_\_\_\_

City, State, Zip: \_\_\_\_\_

CERTIFIED BY:(type or print) \_\_\_\_\_

TITLE: \_\_\_\_\_

\_\_\_\_\_ (signature) \_\_\_\_\_ (date)

## INSURANCE REQUIREMENTS

### 4.0 INSURANCE REQUIREMENTS

Awarded Contractor, at its sole expense, shall obtain and maintain in full force the following insurance to protect the Contractor and the City of Fairhope at limits and coverages specified herein. The City of Fairhope will be listed as an additional insured under the Contractor's General Liability insurance and automobile liability insurance policies, and all other applicable policies and certificates of insurance. These limits and coverages specified are the minimum to be maintained and are not intended to represent the correct insurance needed to fully and adequately protect the awarded Bidder.

**4.01** All insurance will be provided by insurers by admitted carriers in the State of Alabama, shall have a minimum A.M. Best rating of A-VII and must be acceptable to the CITY. Self-insured plans and/or group funds not having an A.M. Best rating must be submitted to the CITY for prior approval.

### **4.02 NO WORK IS TO BE PERFORMED UNTIL PROOF OF COMPLIANCE WITH THE INSURANCE REQUIREMENTS HAS BEEN RECEIVED BY THE CITY.**

#### **4.03 Worker's Compensation and Employer's Liability**

Part One: Statutory Benefits as required by the State of Alabama

Part Two: Employer's Liability	\$1,000,000	each accident
	\$1,000,000	each employee
	\$1,000,000	Policy Limit

#### **4.04 U.S. Longshoreman & Harbor Workers Act (USL&H)**

Required if contract involves work near a navigable waterway that may be subject to the USL&H law.

#### **4.05 Maritime Endorsement (Jones Act)**

Endorsement required if contract involves the use of a Vessel. Or include coverage for "Master or Member or Crew" under "Protection and Indemnity" coverage (P&I) unless crew is covered under Workers Compensation.

Bodily injury by accident	\$1,000,000	each accident
Bodily injury by disease	\$1,000,000	aggregate

#### **4.06 Commercial General Liability**

Coverage on an Occurrence from with a combined single limit of (Bodily Injury and Property Damage combined as follows:

Each occurrence	\$1,000,000
Personal and Advertising Injury	\$1,000,000
Products/Completed Operation Aggregate	\$2,000,000
General Aggregate	\$2,000,000

Coverage to include:

- Premises and operations
- Personal injury and Advertising Injury
- Products/completed operations
- Independent Contractors
- Blanket Contractual Liability
- Explosion, Collapse and Underground hazards
- Broad Form Property Damage
- Railroad Protective Liability Insurance if work involves construction, demolition, or maintenance operations on or within 50 feet of a railroad.

#### **4.07 Automobile Liability**

Covering all owned, non-owned and hired vehicles with a limit of no less than \$1,000,000 combined single limit of Bodily injury and property damage per occurrence.

**4.08 Certificates of Insurance**

A Certificate of Insurance evidencing the above minimum requirements must be provided to and accepted by the CITY PRIOR to commencement of any work on the contract. Each policy shall be endorsed to provide ten (10) days written notice of cancellation to the CITY.

- 4.08.1** The Contractor shall require certificates of insurance from sub-Contractors. Sub-Contractors will carry limits of insurance equal to or greater than those carried by the Contractor. These certificates shall evidence waivers of subrogation in favor of the Contractor and the CITY, and shall be made available to the CITY upon request.



RESOLUTION NO. \_\_\_\_\_

**BE IT RESOLVED BY THE GOVERNING BODY OF THE CITY OF FAIRHOPE, ALABAMA**, as follows:

[1] That the City of Fairhope did vote to procure an IT Consultant for 3-Year Services Contract for the City of Fairhope from CDW Government, LLC through Sourcewell Purchasing Coop with a cost of \$218,161.80. The cost covered all three years of consulting.

[2] That the City of Fairhope hereby terminates the Purchase Order (the Contract) between the City of Fairhope and CDW Government, LLC due to no compromise could be reached by the attorneys for CDW and City of Fairhope.

Adopted on this 22nd day of February, 2021

\_\_\_\_\_  
Jack Burrell, Council President

Attest:

\_\_\_\_\_  
Lisa A. Hanks, MMC  
City Clerk



## MEMO

Date: February 16, 2021

Sherry Sullivan  
Mayor

To: Jill Cabaniss, Finance Manager  
Kim Creech, Treasurer

From:

Delores A Brandt  
Delores A Brandt, Purchasing Manager

**Council Members**

Kevin G. Boone  
Robert A. Brown  
Jack Burrell, ACMO  
Jimmy Conyers  
Corey Martin

Re: **Terminating Contract (PO #) for IT Consultant-3 yr Services  
from CDW Government, LLC through Sourcewell Purchasing COOP**

The IT department is requesting termination of **PO #20210062-00 (the contract)** dated 10/05/2020, with **CDW Government LLC** through contract with Sourcewell 081419—CDW Tech Catalog. CDW Government wanted the City to sign their agreement The Attorneys with CDW Government LLC and the City of Fairhope corresponded through December 2020, reviewing the agreement, and that culminated in the City not wanting to pursue the Contract, as no compromise could be reached.

**Please place on the next City Council agenda this request for the termination of the PO (the Contract) between the City of Fairhope and CDW Government LLC for IT Consultant for three years dated October 5, 2020, in the amount of \$218,161.80**

Cc: file, Jeff Montgomery, Clint Steadham

161 North Section  
Street PO Drawer  
429  
Fairhope, Alabama  
36533

251-928-2136  
251-928-6776 Fax  
[www.fairhopeal.gov](http://www.fairhopeal.gov)

**RESOLUTION NO. 3826-20**

**BE IT RESOLVED BY THE GOVERNING BODY OF THE CITY OF FAIRHOPE, ALABAMA, as follows:**

[1] That the City of Fairhope has voted for procurement of an IT Consultant (Three Year Services) for the City of Fairhope (FY2021, FY2022, and FY2023); and the service is available for direct procurement from CDW Government, LLC through the Sourcewell Purchasing Coop which has been nationally bid; and therefore, does not have to be let out for bid. The Cost will be \$218,161.80 which covers all three years of consulting.

Adopted on this 14th day of September, 2020

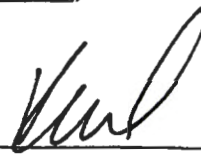

\_\_\_\_\_  
Karin Wilson, Mayor

Attest:

  
\_\_\_\_\_  
Lisa A. Hanks, MMC  
City Clerk

**RESOLUTION NO. \_\_\_\_\_**

**BE IT RESOLVED BY THE GOVERNING BODY OF THE CITY OF FAIRHOPE, ALABAMA,** as follows:

[1] That the City of Fairhope has voted to purchase a 2013 Dodge Ram Flat Crew Cab Dump Truck for the Water Department and the type of vehicle needed is on the Alabama Department of Transportation (ALDOT) surplus equipment list. The total cost not to exceed \$22,957.00.

Adopted on this 22nd day of February, 2021

\_\_\_\_\_  
Jack Burrell, Council President

Attest:

\_\_\_\_\_  
Lisa A. Hanks, MMC  
City Clerk

2/17/2021

City of Fairhope  
Project Funding Request

Issuing Date: 2/17/2021

Received by: *[Signature]*  
Please return this Routing Sheet to Treasurer by: ASAP

Project Name: Procurement of one (1) 2013 Dodge Ram Flat Crew Cab Dump Truck for the Water Department from ALDOT Surplus

Project Location: Water Department

Presented to City Council: 2/22/2021

Funding Request Sponsor: Jason Langley, Water & Sewer Superintendent  
Tim Bung, Supervisor Vehicle mechanics

Project Cash Requirement Requested:  
Cost: \$ 22,957.00

Vendor: Alabama Department of Transportation

Project Engineer: n/a

Order Date: n/a Lead Time: n/a

Resolution # :  
Approved \_\_\_\_\_  
Changed \_\_\_\_\_  
Rejected \_\_\_\_\_

Department Funding This Project

General  Gas  Electric  **Water**  Sewer  Gas Tax  Cap Project  Impact  Health  Fed Grant

Department of General Fund Providing the Funding

Admin-10  Bldg-13  Police-15  Fire-20  ECD-24  Rec-25  Civic-26  Street-35  Sanitation-40   
Fac Maint-45  Golf-50  Golf Grounds-55  Museum-70  Debt Service-85  Marina-34  Plan/Zone

Project will be:

Expensed   
Capitalized XXX   
Inventoried

Funding Source:

Operating Expenses   
Budgeted Capital XXX   
Unfunded

Expense Code: 004-16030  
G/L Acct Name: Capital Purchases V&E

Project Budgeted: \$ 40,000.00

Balance Sheet Item-  
Included in projected  
cash flow

Over (Under) budget amount: \$ (17,043.00)

Comments:

Grant: \_\_\_\_\_ Federal - not to exceed amount  
\_\_\_\_\_ State  
\_\_\_\_\_ City  
\$0.00 Local

Bond: \_\_\_\_\_ Title \_\_\_\_\_ Year \_\_\_\_\_  
Loan: \_\_\_\_\_ Title \_\_\_\_\_ Year \_\_\_\_\_

Capital Lease: \_\_\_\_\_ - Payment \_\_\_\_\_ Term \_\_\_\_\_

City Council Prior Approval/Date? \_\_\_\_\_

Finance Manager: \_\_\_\_\_ City Treasurer: \_\_\_\_\_ Mayor: \_\_\_\_\_

Purchasing Memo Date: 2/15/2021 Purchasing Memo Date: 2/15/2021 Delivered To Date: 2/17/2021

Request Approved Date: 2/17/2021 Request Approved Date: 2/17/2021 Approved Date: \_\_\_\_\_

Signatures: Jill Cabaniss, MBA Kim Creech Mayor Sherry Sullivan



**MEMO**

Sherry Sullivan  
Mayor

To: Kimberly Creech, Treasurer  
From: *Delores A Brandt*  
Delores A Brandt, Purchasing Manager

*Council Members:*  
Kevin G. Boone  
Robert A. Brown  
Jack Burrell, ACOMO  
Jimmy Conyers  
Corey Martin

Date: February 15, 2021

Lisa A. Hanks, MMC  
City Clerk

Re: Request for Greensheet and CC Approval of procurement of budgeted, over \$10,000, request for ONE (1) used RAM 3500 Crew Cab Dump Truck for Water Department from ALDOT Surplus

The Water Department Superintendent, Jason Langley is requesting procurement of ONE (1) USED RAM 3500 CREW Cab Dump Truck from ALDOT SURPLUS Property. This is a 2013 Dodge RAM 3500 Flat Crew Cab with 82,759 miles and priced at **TWENTY-TWO THOUSAND NINE HUNDRED FIFTY-SEVEN DOLLARS (\$22,957.00)** plus delivery.

The State invoice from the Alabama Department of Transportation (ALDOT) Equipment Bureau is attached.

NOTES:

See Attached Vendor CUT-SHEET printout for details.  
Delivery/pickup Approximately 10-12 weeks ARO

**Please compose a greensheet and place on the next available City Council Agenda this request to approve this budgeted procurement for one (1) Used 2013 RAM 3500 CREW Cab Dump Truck from ALDOT Surplus Property in the estimated amount of \$22,957.00 plus delivery.**

CC file, Jason Langley, Tim Bung, Clint Steadham

161 North Section  
Street PO Drawer 429  
Fairhope, Alabama  
36533

251-928-2136

251-928-6776 Fax  
[www.fairhopeal.gov](http://www.fairhopeal.gov)

# CITY OF FAIRHOPE PURCHASING DEPARTMENT REQUEST FORM

Name: Jason S Langley

Date: 2/15/2021

Department: Water & Sewer

## ITEM OR SERVICE INFORMATION

1. **What item or service do you need to purchase?** Ram 3500 Dump ALDOT Surplus Property
2. **What is the total cost of the item or service?** 22,957.00
3. **Where will the item or service be physically located?** 555 S. Section Street
4. **What is the primary function of the item or service?** Dump Truck to be used by the Water and Sewer department.
5. **How many do you need?** One
6. **Item or Service Is:**  New  Used  Replacement  Annual Request
7. **When do you anticipate implementation?** Soon as possible
8. **Additional Information or Comments:** Budgeted Dump Truck for our department. By utilizing ALDOT Surplus Property there is significant cost savings. ALDOT has a history of well-maintained equipment.
9. **Vendor Name:** Alabama Department of Transportation
10. **Vendor Number:** Click or tap here to enter text.

## BUDGET INFORMATION

1. **Is it budgeted?**  Yes  No  Emergency Request
2. **If budgeted, what is the budgeted amount?** <sup>20,000</sup> \$2250-Water, <sup>20,000</sup> \$2250 Sewer *Small Dump Truck*
3. **What is the Capital Project Name or Budget Code:** 004-1630016030
4. **Check any applicable boxes:**  State Contract  ALDOT  Purchasing Group  
 Sole Source (Attach Sole Source Justification)

Email completed form with quotes and other supporting documentation to [deedee.brandt@fairhopeal.gov](mailto:deedee.brandt@fairhopeal.gov) and [jennifer.bush@fairhopeal.gov](mailto:jennifer.bush@fairhopeal.gov).

Date 02/12/2021  
Buyer No.: 63600125400

AUDITOR'S # \_\_\_\_\_  
INVOICE/SD-1 NO 6536

**STATE INVOICE**  
**ALABAMA DEPARTMENT OF TRANSPORTATION**  
**EQUIPMENT BUREAU**  
**1409 COLISEUM Blvd.**  
**Montgomery, Alabama 36110**  
**Telephone (334) 242-6248**

Buyer Name: City Of Fairhope  
Buyer Address: 161 N. Section Street  
P.O. BOX 429  
FAIRHOPE AL 36533-0429

MAKE CHECK PAYABLE TO: ALABAMA DEPARTMENT OF TRANSPORTATION  
AND REMIT TO ABOVE ADDRESS ATTENTION: Susan Horton

**A COPY OF THIS INVOICE MUST ACCOMPANY REMITTANCE**

Inventory Number	Act No	Description of Property	Serial Number	Make	Model	Mileage	Tag No	Total
ST015108	07	FLAT CREW CAB DUMP GAS 1T	3C7WRSC9DG553090	RAM	2013	82,759	004770A	\$22,957.00

All sales are as is per terms of the eligibility application. Payment must be made within 30 days from the date of the invoice. Any Title or Bill of Sale will be sent after payment is received.

Total Charge **\$22,957.00**  
(pay this amount)

Picked Up By \_\_\_\_\_

Picked Up Date \_\_\_\_\_

Equip. Released By \_\_\_\_\_

Authorized Purchaser \_\_\_\_\_

Printed Name

Signature

*EQUIPMENT BUREAU USE ONLY*

Sale Approved/Property Released by: \_\_\_\_\_  
Department of Transportation Property Manager Date



## Kimberly Creech

---

**From:** Sherry Sullivan  
**Sent:** Sunday, February 14, 2021 11:39 AM  
**To:** Kimberly Creech  
**Subject:** FW: ALDOT WEB INVOICE # 6536 - CONFIRMATION

-----Original Message-----

From: Equipment Bureau <equipmentbureau@dot.state.al.us>  
Sent: Friday, February 12, 2021 5:31 PM  
To: equipmentbureau@dot.state.al.us; Tim Bung <Tim.Bung@fairhopeal.gov>  
Cc: Sherry Sullivan <sherry.sullivan@fairhopeal.gov>  
Subject: ALDOT WEB INVOICE # 6536 - CONFIRMATION

SENT FROM AN EXTERNAL ADDRESS

---

This message has been automatically generated.

This is a confirmation for invoice # 6536. The purchaser must submit a SIGNED copy of the invoice printed off the web within 7 BUSINESS DAYS to Alabama DOT. The asset(s) on invoice 6536 will become available for others to purchase after the 7th business day if ALDOT has not received a signed invoice.

Agency/Organization: City Of Fairhope  
Authorized Purchaser for Agency/Organization: Tim Bung

The following assets were purchased on this invoice

ST-015108 (07)3C7WRSCT9DG553090 RAM 2013 Salvage Yard - Montgomery, AL \$22,957.00

Total Price: \$22,957.00

Please direct any questions to the Alabama DOT Equipment Bureau by email by responding to this email message or by telephone at (334) 242-6266.

**RESOLUTION NO. \_\_\_\_\_**

**BE IT RESOLVED BY THE GOVERNING BODY OF THE CITY OF FAIRHOPE, ALABAMA**, as follows:

[1] That the City of Fairhope has voted to purchase a 2014 Ford Crane Truck for Public Works Department to be used for painting of signs; and the type of vehicle needed is on the Alabama Department of Transportation (ALDOT) surplus equipment list. The total cost not to exceed \$30,000.00.

Adopted on this 22nd day of February, 2021

\_\_\_\_\_  
Jack Burrell, Council President

Attest:

\_\_\_\_\_  
Lisa A. Hanks, MMC  
City Clerk

2/17/2021

Received  
ASAP

City of Fairhope  
Project Funding Request

Issuing Date: 2/17/2021

Please return this Routing Sheet to Treasurer by: ASAP

Project Name: Procurement of one (1) 2014 Ford Crane Truck from ALDOT Surplus to be used for painting of signs

Project Location: Street Department

Presented to City Council: 2/22/2021

Funding Request Sponsor: Richard Johnson, Public Works Director  
Tim Bung, Supervisor Vehicle mechanics

Resolution # :  
Approved \_\_\_\_\_  
Changed \_\_\_\_\_  
Rejected \_\_\_\_\_

Project Cash Requirement Requested:  
Cost: \$ 30,000.00

Vendor: Alabama Department of Transportation

Project Engineer: n/a

Order Date: n/a Lead Time: n/a

Department Funding This Project

General  Gas  Electric  Water  Sewer  Gas Tax  Cap Project  Impact  Health  Fed Grant

Department of General Fund Providing the Funding

Admin-10  Bldg-13  Police-15  Fire-20  ECD-24  Rec-25  Civic-26  **Street-35**  Sanitation-40   
Fac Maint-45  Golf-50  Golf Grounds-55  Museum-70  Debt Service-85  Marine-34  Plan/Zone

Project will be:

Expensed \_\_\_\_\_   
Capitalized XXX   
Inventoried \_\_\_\_\_

Funding Source:

Operating Expenses \_\_\_\_\_   
Budgeted Capital XXX   
Unfunded \_\_\_\_\_

Expense Code: 001350-50470  
G/L Acct Name: Capital Purchases V&E

Grant: \_\_\_\_\_ Federal - not to exceed amount  
\_\_\_\_\_ State  
\_\_\_\_\_ City  
\$0.00 Local

Project Budgeted: \$ 45,000.00  
Balance Sheet Item Included in projected cash flow

Over (Under) budget amount: \$ (15,000.00)

Comments:

Bond: \_\_\_\_\_ Title \_\_\_\_\_ Year \_\_\_\_\_  
Loan: \_\_\_\_\_ Title \_\_\_\_\_ Year \_\_\_\_\_

Capital Lease: \_\_\_\_\_ - Payment \_\_\_\_\_ Term \_\_\_\_\_

City Council Prior Approval/Date? \_\_\_\_\_

Finance Manager: \_\_\_\_\_ City Treasurer: \_\_\_\_\_ Mayor: \_\_\_\_\_

Purchasing Memo Date: 2/17/2021 Purchasing Memo Date: 2/17/2021 Delivered To Date: 2/17/2021

Request Approved Date: 2/17/2021 Request Approved Date: 2/17/2021 Approved Date: \_\_\_\_\_

Signatures: Jill Cabaniss, MBA Kim Creech Sherry Sullivan  
Jill Cabaniss, MBA Kim Creech Mayor Sherry Sullivan



**MEMO**

To: Kimberly Creech, Treasurer  
From: Delores A Brandt  
Delores A Brandt, Purchasing Manager

Sherry Sullivan  
Mayor

Date: February 17, 2021

*Council Members:*

Kevin G. Boone  
Robert A. Brown  
Jack Burrell, ACOMO  
Jimmy Conyers  
Corey Martin

Lisa A. Hanks, MMC  
City Clerk

Re: Request for **Greensheet and CC Approval of procurement of budgeted, over \$10,000, request for ONE (1) used Crane Truck for Public Works Department from ALDOT Surplus to be used for painting of signs**

The Director of Public Works, Richard Johnson, and Fleet Maintenance Dept, Tim Bung, are requesting procurement of ONE (1) USED gas powered 1 ½ ton Crane Truck from ALDOT SURPLUS Property with 65,501 miles and priced at THIRTY THOUSAND DOLLARS (\$30,000.00) plus delivery. This was budgeted in FY2021 for \$45,000.

The State invoice # 6538 from the Alabama Department of Transportation (ALDOT) Equipment Bureau is attached.

NOTES:

See Attached Vendor CUT-SHEET printout for details.  
Delivery/pickup Approximately IMMEDIATELY

**Please compose a greensheet and place on the next available City Council Agenda this request to approve this budgeted procurement for one (1) used Crane Truck for Public Works Department from ALDOT Surplus Property in the estimated amount of \$30,000.00 plus delivery.**

161 North Section  
Street PO Drawer 429  
Fairhope, Alabama  
36533

251-928-2136

251-928-6776 Fax  
[www.fairhopeal.gov](http://www.fairhopeal.gov)

CC file, Richard Johnson, Tim Bung, Clint Steadham

# CITY OF FAIRHOPE PURCHASING DEPARTMENT REQUEST FORM

**Name:** Tim Bung for Richard Johnson

**Date:** 2/16/2021

**Department:** PW

## ITEM OR SERVICE INFORMATION

- 1. What item or service do you need to purchase?** Crane Truck Mounted Hoist
- 2. What is the total cost of the item or service?** \$30,000 ( time B will pick it up)
- 3. Where will the item or service be physically located?** PW
- 4. What is the primary function of the item or service?** Sign truck
- 5. How many do you need?** one
- 6. Item or Service Is:**  New  Used  Replacement  Annual Request
- 7. When do you anticipate implementation?** ASAP
- 8. Additional Information or Comments:** ALDOT Surplus. Will be picked up by Tim Bung Replacing truck now in use.
- 9. Vendor Name:** ALDOT
- 10. Vendor Number:** Click or tap here to enter text.

## BUDGET INFORMATION

- 1. Is it budgeted?**  Yes  No  Emergency Request
- 2. If budgeted, what is the budgeted amount?** \$45,000 ?
- 3. What is the Capital Project Name or Budget Code:** 001350-50470
- 4. Check any applicable boxes:**  State Contract  ALDOT  Purchasing Group  
 Sole Source (Attach Sole Source Justification)

*Email completed form with quotes and other supporting documentation to  
[deedee.brandt@fairhopeal.gov](mailto:deedee.brandt@fairhopeal.gov) and [jennifer.bush@fairhopeal.gov](mailto:jennifer.bush@fairhopeal.gov).*

Date: 2/12/2021

AUDITOR'S # \_\_\_\_\_

Page 1 of 1

**STATE INVOICE**  
**ALABAMA DEPARTMENT OF TRANSPORTATION**  
**EQUIPMENT BUREAU**

1409 Coliseum Blvd.  
Montgomery, Alabama 36110  
Telephone: (334) 242-6248

Buyer No: **63600125400**

INVOICE/SD-1 NO. **6538**

Buyer Name: City Of Fairhope

Buyer Address: 161 N. Section Street

FAIRHOPE, AL 36533-0429

*MAKE CHECKS PAYABLE TO: ALABAMA DEPARTMENT OF TRANSPORTATION AND REMIT TO ABOVE ADDRESS ATTENTION: Susan Horton*

<b>A COPY OF THIS INVOICE MUST ACCOMPANY ANY REMITTANCE</b>				
<b>Inventory #</b>	<b>ACCT#</b>	<b>Description</b>	<b>Serial Number</b>	<b>PRICE</b>
CH078471	07	CRANE, TRUCK MOUNTED HOIST Mileage: 0	69246	\$0.00
ST015202	07	TRUCK W/SERVICE BODY GAS 1-1/2TON Mileage: 65501.00	1FDUF4GY1EEA23070	\$30,000.00
<b>Total Charge:</b>				<b>\$30,000.00</b>

**All sales as in per terms of the eligibilty application. Payment must be made within 30 days from the date of this invoice. Any Titles or Bill of State will be sent after payment**

Picked up By: \_\_\_\_\_

Picked up Date: \_\_\_\_\_

Equipment Released by: \_\_\_\_\_

AUTHORIZED PURCHASER: \_\_\_\_\_

Print Name

Signature

**EQUIPMENT BUREAU USE ONLY**

Sale approved/Property Released by: \_\_\_\_\_

Department of Transportation Property Inventory Officer

Date Signed: \_\_\_\_\_

## Kimberly Creech

---

**From:** Sherry Sullivan  
**Sent:** Sunday, February 14, 2021 11:39 AM  
**To:** Kimberly Creech  
**Subject:** FW: ALDOT WEB INVOICE # 6538 - CONFIRMATION

-----Original Message-----

From: Equipment Bureau <equipmentbureau@dot.state.al.us>  
Sent: Friday, February 12, 2021 5:31 PM  
To: equipmentbureau@dot.state.al.us; Tim Bung <Tim.Bung@fairhopeal.gov>  
Cc: Sherry Sullivan <sherry.sullivan@fairhopeal.gov>  
Subject: ALDOT WEB INVOICE # 6538 - CONFIRMATION

SENT FROM AN EXTERNAL ADDRESS

---

This message has been automatically generated.

This is a confirmation for invoice # 6538. The purchaser must submit a SIGNED copy of the invoice printed off the web within 7 BUSINESS DAYS to Alabama DOT. The asset(s) on invoice 6538 will become available for others to purchase after the 7th business day if ALDOT has not received a signed invoice.

Agency/Organization: City Of Fairhope  
Authorized Purchaser for Agency/Organization: Tim Bung

The following assets were purchased on this invoice

ST-015202 (07)1FDUF4GY1EEA23070 FORD 2014 Salvage Yard - Montgomery, AL \$30,000.00  
CH-078471 (07)69246 VENTURO 2013 Salvage Yard - Montgomery, AL \$.00

Total Price: \$30,000.00

Please direct any questions to the Alabama DOT Equipment Bureau by email by responding to this email message or by telephone at (334) 242-6266.

# ~~CANCELLATION / DATE CHANGE FORM~~

NAME OF RENTER: EASTERN SHORE REPERTORY THEATRE  
ADDRESS: PO Box 951  
CITY: Fairhope STATE: AL ZIP: 36532  
PHONE: 251.747.5354  
LOCATION OF FUNCTION: Henry George Bluff  
DATE OF FUNCTION: 01MAY20 - 11MAY20

I wish to cancel this reservation. I understand that if this cancellation is made within 30 days of the event, I will not receive a refund. Outside the 30 days, I will receive a refund for the amount of the deposit less a 20% handling fee.

I wish to change the date of this event to:

NEW DATE OF FUNCTION: 30APR21 - 10MAY21

Braida Sharpe  
RENTER'S SIGNATURE

2.13.2021

TODAY'S DATE

[Signature]  
BANQUET MANAGERS SIGNATURE

15FEB21

TODAY'S DATE



**APPLICATION FOR THE USE OF CITY OF FAIRHOPE PARKLANDS**

We, the undersigned, hereby apply for the use of certain facilities at City of Fairhope Parklands, and in connection with said application, furnish the following:

- 1. We wish to use:
  - Henry George Park (park on bluff above Fire Hall) (E)
  - Fairhope Beach Pavilion (W & E)
  - Park on South End of Pier (South Beach Park) (W&E)
- 2. Date Requested: April 30 - May 9, 2021 Hours requested: from 8 am to 11pm
- 3. Renter's Name: Eastern Shore Repertory Theatre INC
- 4. Address: P O Box 951 City: Fairhope State: AL Zip: 36532
- 5. Phone Numbers: Mobile: 251-747-5354 Work/Alt: \_\_\_\_\_
- 6. Purpose of Use: Theatre on the Bluff - Spring Play
- 7. Number of persons expected to attend (adults and minors): \_\_\_\_\_
- 8. Describe any decorations, tents, sound equipment, staging, port-o-lets, etc.: Tents, Sound Equipment, Staging, Port-o-Lets, Signs, Food Trucks Rental Company: \_\_\_\_\_
- 9. Will you need electricity?  Yes  No For: \_\_\_\_\_
- Will you need water?  Yes  No For: \_\_\_\_\_

**INDEMNITY AND HOLD HARMLESS AGREEMENT**

In consideration of the permission granted to me by the City of Fairhope to use the parks, I hereby indemnify and hold harmless the City of Fairhope, its agents, servants and employees from any and all claims and causes of action that may arise from injury to me or third parties using the parks who are injured or suffer property damage that is in any way caused by my use of the parks. This indemnity and hold harmless agreement is given to the City of Fairhope to protect the City and its agents, servants and employees from cost of defense and claims for injuries and damages that may be caused either directly or indirectly by my use of the parks.

**CLEANING & CANCELLATION POLICIES**

- a.) At the conclusion of the event, the area will be inspected by a representative of the City. If the user has not cleaned up the park and restored it to its original condition, the City will clean up the park and charge the user for the services.
- b.) All cancellations and/or date changes must be in writing and signed by the same person who signed the application and paid the rental fees, and must be given to the Site Manager not less than 30 days prior to the event. No fee refunds will be made for cancellations made less than 30 days prior to the event.

Fee refunds will be made by check, and delivered by mail, less the cost of City services, as assessed by the appropriate City staff for cleaning, or a 20% handling charge for cancellations.

We the undersigned have read and understand the **Indemnity Agreement**, as well as all rules and regulations contained in **City Ordinance No. 1575** as set forth by the governing body of the City of Fairhope and will abide by these rules and regulations, which include but are not limited to the **Cancellation** and **Cleaning** policies. We also understand that if, at any time, the City-appointed Law Enforcement Personnel feel that said rules and regulations are not being followed, the function will be terminated.

Renter's Signature: Braida Sharpe Date: 11.25.2020

City Personnel: Chuck [Signature] Fees Paid: \$4875.00 Date: 19 JAN 2021 Ck. #: 2004

-Office Use Only-

Application Signed Dated 11/25/20 Permit Deposit Fees 4875 Entered in Calendar 11/25/20

City of Fairhope

Approval Special Event Request

Date complete application submitted to Rental Facilities Department

Event: Eastern Shore Repertory Theatre

Person Requesting: Erin Langley

Date of Event: April 30 - May 11, 2021

Location: Henry George Bluf

Approval/Disapproval supporting documentation attached.

Approval:



Police Chief/Designee

Date: 2/15/21

Approx. security cost

Off-Duty  
\$ 1,600

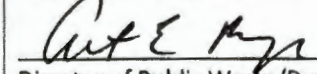

Director of Public Works/Designee

Date: 2-12-21

Approx. cost city services

\$ 1,000

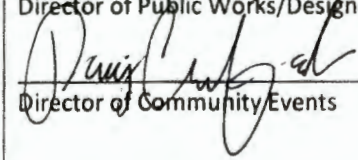

Director of Community Events

Date: 2-15-2021

Disapproval:

\_\_\_\_\_  
Date: \_\_\_\_\_  
Police Chief

\_\_\_\_\_  
Date: \_\_\_\_\_  
Director of Public Works/Designee

\_\_\_\_\_  
Date: \_\_\_\_\_  
Director of Community Events

Route back to rental facilities department for application package finalization

NOTES: \_\_\_\_\_

## CITY OF FAIRHOPE PARK AND/OR STREET USAGE CHECKLIST

ALL INFORMATION AND DOCUMENTATION REGARDING YOUR EVENT MUST BE SUBMITTED TO  
THE CITY OF FAIRHOPE AT LEAST 12 WEEKS PRIOR TO YOUR EVENT  
ANY DOCUMENTATION THAT IS SUBMITTED LESS THAN 12 WEEKS WILL NOT BE ACCEPTED

1. Application, Cancellation Policy, Indemnity/Hold Harmless Agreement completed, signed, and dated.
2. A copy of the letter to the City Council if you are making any special requests which include but are not limited to street closing, permission to have alcohol, law enforcement personnel, barricades, and other event details.
3. Route/Map of Special Event [Emergency Vehicle (i.e. police, fire, etc.) access must be provided]  
Estimated Law Enforcement/Personnel Cost: \$ \_\_\_\_\_
- \_\_\_ 4. NON-PROFIT ORGANIZATIONS: Proof of nonprofit status (IRS letterhead)
- \_\_\_ 5. Proof of liability insurance for event naming the City of Fairhope as certificate holder with date of event requested.
- \_\_\_ 6. For Street Closings within the Central Business District, signatures from 75% businesses/residences and notification to 100% of the businesses/residences within 300 feet of the location of event. (12 weeks prior to event)
- \_\_\_ 7. For Street Closings outside the Central Business District, signatures from adjacent businesses within 300 feet of event (12 weeks prior to event) and notification of all businesses/residents along race route (30 days prior to event).
- \_\_\_ 8. For South Park Events, signatures from:  
Shook's Restaurants \_\_\_\_\_ Date: \_\_\_\_\_  
Down by the Bay Cafes \_\_\_\_\_ Date: \_\_\_\_\_
- \_\_\_ 9. Event details (Items, including the ones listed below, must be removed immediately following event and park/street cleaned and restored to original condition. (If not, additional fees will be incurred.)
- Law Enforcement Personnel Provided by: \_\_\_\_\_
- Barricades Provided by: \_\_\_\_\_
- Staging Provided by: \_\_\_\_\_
- Tents Provided by: \_\_\_\_\_
- Port-o-lets provided by: \_\_\_\_\_
- \_\_\_ Special transportation needs provided by: \_\_\_\_\_
- \_\_\_ Special electrical needs: \_\_\_\_\_
- \_\_\_ 10. AGENDA DATE TO MEET WITH CITY COUNCIL (if required): \_\_\_\_\_

*Office use only*

\_\_\_ Street closing approved \_\_\_ Alcohol approved \_\_\_ ABC License if selling alcohol \_\_\_ Park/Street permit fees paid

**APPLICATION FOR THE USE OF CITY OF FAIRHOPE PARKLANDS**

We, the undersigned, hereby apply for the use of certain facilities at City of Fairhope Parklands, and in connection with said application, furnish the following:

1. We wish to use:
  - Henry George Park (park on bluff above Fire Hall) (E)
  - Fairhope Beach Pavilion (W & E)
  - Park on South End of Pier (South Beach Park) (W&E)
2. Date Requested: May 1 - 11 2020 Hours requested: from \_\_\_\_\_ to \_\_\_\_\_
3. Renter's Name: Eastern Shore Repertory Theatre
4. Address: P.O. Box 951 City: Fairhope State: AL Zip: 36532
5. Phone Numbers: Mobile: 251-747-5354 Work/Alt: \_\_\_\_\_
6. Purpose of Use: Theater on The Bluff
7. Number of persons expected to attend (adults and minors): 800 +
8. Describe any decorations, tents, sound equipment, staging, port-o-lets, etc.: tents stage, sound equipment  
port-o-lets etc. . . . . Rental Company: \_\_\_\_\_
9. Will you need electricity?  Yes  No For: Theater on the Bluff
- Will you need water?  Yes  No For: " " "

ORIGINAL DOCUMENT HAS A SECURITY VOID BACKGROUND PANTOGRAPH, MICROPRINTED BORDER - SEE REVERSE SIDE FOR COMPLETE SECURITY FEATURES

**Eastern Shore Repertory Theatre INC**  
P O Box 951  
Fairhope, AL 36532

TCB  
The Citizens Bank

002004

DATE 6/5/19

PAY TO THE ORDER OF City of Fairhope \$ 4,875  
Four Thousand Eight Hundred Seventy Five DOLLARS

MEMO: 2020 Theater on Bluff George Henry Park AUTHORIZED SIGNATURE

⑈002004⑈ ⑆062105710⑆ 159883701⑈

THIS DOCUMENT CONTAINS HEAT SENSITIVE INK. TOUCH OR PRESS AND RED IMAGE DISAPPEARS WITH HEAT.

**Ordinance No. 1575** as set forth by the governing body of the City of Fairhope and will abide by these rules and regulations, which include but are not limited to the **Cancellation and Cleaning** policies. We also understand that if, at any time, the City-appointed Law Enforcement Personnel feel that said rules and regulations are not being followed, the function will be terminated.

Renter's Signature: \_\_\_\_\_ Date: 5/5/19  
City Personnel: [Signature] Fees Paid: \$4,875.00 Date: 5-5-19 Ck. #: 2004

-Office Use Only-

Application Signed/Dated \_\_\_\_\_ Permit/Deposit Fees \_\_\_\_\_ Entered in Calendar \_\_\_\_\_

**City of Fairhope  
Park & Street Usage Charges**

**(per city ordinance No. 1575, 1576, & 1486)**

Fairhope Civic Center, P.O. Drawer 429, Fairhope AL 36533 - (251) 929-1479 / 990-0130 (251) 929-1467[Fax]

Name: Eastern Shore Repertory

Address: PO Box 951 Fairhope AL 36533

Date of function: May 1st - 11th, 2020 Phone: 251-751-2935 No. in attendance: 700-900

**FEE SCHEDULE**

Park Rental Fee: \$150. per diem	\$1,650.
Street Rental Fee: \$150. per diem	_____

Subtotal: \$1,650.

Non-profit organization; exempt from 50% rental fees.  
\*Proof of 501 non-profit must be on file.

50% Non-Profit Rate : \$825.

Additional Hours – past allotted four hour: @ \$75 per hour	\$3,000.
Electric/Water Fee: (one time charge of \$50.)	<u>\$50.</u>
Refundable Clean-up Deposit: (Required)	<u>\$1,000.</u>

**Balance Due:** \$4,875.

Less cleaning fee: - \_\_\_\_\_

(50% non-profit rate) - \_\_\_\_\_

Refund Due: \_\_\_\_\_

\*Refunds for clean-up deposit to be mailed to address given on rental application, three weeks after event.\*

Notes: Hourly fees assessed on a 12-hr/day basis, less 4 hr. provision for each day of usage. No hourly fees will be

charged for Monday strike day. 10 days x 8 hrs./day= 80 hrs (.5 non-profit)(\$75. per hr.) = \$3,000.00 hourly fee

Paid: \$4,875.00 Check# /Cash 2004 Date: 6-5-19

CITY OF FAIRHOPE  
CITY HALL  
PO DRAWER 429  
FAIRHOPE, AL 36533  
251-928-2136

015419-0070 Megan G. 06/05/2019 02:48PM

MISCELLANEOUS

PARK/SIDEWALK USAGE FEE  
(41080)

2019 Item: 41080

1.00 @ 4,875.00

PARK/SIDEWALK USAGE FEE  
(41080)

4,875.00

-----  
4,875.00

Subtotal

4,875.00

Total

4,875.00

CHECK

4,875.00

Check Number 002004

Change due

-----  
0.00

Paid by: EASTERN SHORE

161 N SECTION ST, FAIRHOPE, AL 36532  
<http://www.fairhopeal.gov>

CITY OF FAIRHOPE COPY  
DUPLICATE RECEIPT

EASTERN SHORE  
 REPERTORY  
THEATRE

June 12, 2019

To the Fairhope City Council Members:

On behalf of Eastern Shore Repertory Theatre, I would like to whole-heartedly thank you for your support in allowing our spring productions of "Joseph and the Amazing Technicolor Dreamcoat," "The Music Man," "Bye Bye Birdie," "The Little Mermaid," "NEWSIES" and "Matilda" at the Henry George Bluff. We have had a beautiful weekends of weather and tremendous community support. We hope that we have, in a small way, added to the artistic texture of Fairhope. Because of the positive feedback of the community, we would like to request usage of the Henry George Bluff for May 1-11, 2020. We will tentatively be performing the musical, "Beauty and the Beast" and will include 90 plus members of our Eastern Shore community as actors. We will again have David Redman Scott (our guest director from Disney Theatrical Productions in New York City)'s support and guidance. We will schedule 3 performances in order to better seat the community: May 7-9, 2020 at 7:30 pm with a rain date or possible encore performance on May 10th.

Our request would be similar to the spring 2014-2019 rentals. We would request usage of the City's barricades, and to have City employees to assist in the setup and removal of these.

We will plan on using a generator for any additional power needed and will pay for a police officers' assistance during performances.  
Thank you again for your support!

Sincerely,

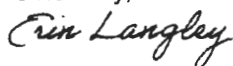

Erin Langley  
Executive Director

8 July 2019

Councilmember Conyers moved to reappoint Vann Saltz to the Recreation Board for a five-year term which will expire April 2024. Seconded by Councilmember Robinson. motion passed unanimously by voice vote.

Councilmember Conyers moved to grant the request of Mary Riser, Executive Director of Fairhope Film Festival – Requesting permission to close S Summit Street (between Fairhope Avenue and S Summit near St. James) on Saturday, November 16, 2019 from 4:00 p.m. to 11:00 p.m. for the Red Carpet Party, and the use of 10 barricades, 4 trash cans and electric power hook-up.

Also requesting use of the Welcome Center on Section Street as our Box Office from Wednesday, November 13, 2019 through Sunday, November 17, 2019. Times are listed on letter of request. Requesting use of the City public area near the Fairhope Clock adjacent to the flowerbed and near the Northeast Corner of Fairhope Avenue and Section, and signage and additional publicity in City notifications from October 24, 2019 through November 17, 2019 (requesting a minimum of 6 pole banners to be hung 14 days prior to and during Festival). Seconded by Councilmember Boone. motion passed unanimously by voice vote.

Councilmember Conyers moved to grant the request of Erin Langley, Eastern Shore Repertory Theatre, Inc. - Requesting permission to use Henry George Park from May 1, 2020 through May 11, 2020 for the tentative performance of "Beauty and the Beast" with performances being held May 7, 2020 through May 9, 2020 at 7:30 p.m., and usage of barricades and to have City employees assist in setup and removal of these. Seconded by Councilmember Robinson. motion passed unanimously by voice vote.

At the request of the City Attorney, Marcus E. McDowell, the City Council will rise from the meeting to go into Executive Session based on § 36-25A-7(a)(3) to discuss pending litigation and possible settlement options regarding said pending litigation, and § 36-25A-7(a)(6) to discuss the consideration the City is willing to offer or accept when considering the purchase, sale, exchange, lease, or market value of real property. The discussions could have a detrimental effect upon the competitive position of the City in the negotiations if the matter was discussed in public. The approximate time to be in Executive Session is 45 minutes. Councilmember Brown moved to go into Executive Session. Seconded by Councilmember Boone. motion passed unanimously by voice vote.

Exited the dais at 6:25 p.m. Returned at 7:08 p.m.

Best,

Michael Stonehouse  
[michael.stonehouse@fairhopeal.gov](mailto:michael.stonehouse@fairhopeal.gov)  
Rental Facilities Manager  
City of Fairhope  
251-990-0130  
251-929-1467 Fax

**From:** Eastern Shore Repertory Theatre <[esrt@easternshorerep.org](mailto:esrt@easternshorerep.org)>  
**Sent:** Thursday, January 30, 2020 12:46 PM  
**To:** Michael Stonehouse <[Michael.Stonehouse@fairhopeal.gov](mailto:Michael.Stonehouse@fairhopeal.gov)>; Chuck Milan <[charles.milan@fairhopeal.gov](mailto:charles.milan@fairhopeal.gov)>  
**Subject:** Spring on the Bluff



CITY OF FAIRHOPE  
CITY HALL  
PO DRAWER 429  
FAIRHOPE, AL. 36533  
251-928-2136

015419-0070 Megan G. 06/05/2019 02:46PM

**MISCELLANEOUS**

PARK/SIDEWALK USAGE FEE  
(41080)

2019 Item: 41080

1.00 @ 4,875.00

PARK/SIDEWALK USAGE FEE  
(41080)

4,875.00

-----  
4,875.00

Subtotal 4,875.00

Total 4,875.00

CHECK 4,875.00

Check Number 002004

Charge due 0.00

Paid by: EASTERN SHOP

161 N SECTION ST FAIRHOPE AL 36532  
<http://www.fairhopeal.gov>

CITY OF FAIRHOPE COPY  
DUPLICATE RECEIPT

Erin Langley  
Eastern Shore Repertory Theatre  
1410 Captain O'Neal Drive  
Daphne, AL 36526  
251-751-2935  
erinlangley@me.com

November 30, 2020

Dear Fairhope City Council Members:

On behalf of Eastern Shore Repertory Theatre, I would like to whole-heartedly thank the City of Fairhope, our City Council and Mayor, for your support of our "Theatre on the Bluff" performances which have taken place on the Henry George Bluff since 2014. We have graciously appreciated the incredible attendance from our local community and we feel honored to be a part of another special Fairhope tradition. We hope that our musicals have added to the artistic texture of Fairhope.

As you know, 2020 has been a difficult year for all, especially arts and non-profit organizations. We were disappointed to have to cancel our May 2020 show at the bluff, though we fully realize it was the responsible choice. Since that cancellation, Eastern Shore Repertory Theatre has become adaptive to our current environment and has found many creative ways to keep the arts alive on the Eastern Shore. We've added a medical professional, Dr. Paul Glisson, Chief Medical Officer and Vice President of Medical Affairs of Baptist Health Care to our Board of Directors for medical advice. We've held virtual performances and socially distanced summer camps in order to keep our students and audiences safer. We also successfully completed an outdoors haunted forest performance walk for several thousand audience members over three weeks who were all socially distanced. We have followed all state and CDC recommendations during these projects.

We believe that a Theatre on the Bluff performance this May is attainable with creativity and safety measures put in place, continuing to follow state and CDC recommendations. We would like to perform the classic, "The Wizard of Oz" to bring joy and life to our youngest to most mature community members. Theatre on the Bluff is a local event, using actors from the Eastern Shore and drawing in residents of our area; we do not generally draw crowds from other areas. We would schedule three performances: May 6-8, 2021 with a rain date or possible encore performance on May 9th.

Our request would be similar to past rentals. We would request usage from April 30- May 11, 2021. We would ask for usage of the City's barricades and to have the City employees assist in the setup and removal of the barricades. We would use a generator for additional power and will pay for police assistance during performances.

Thank you for your consideration! Eastern Shore Rep would be thrilled to offer this artistic opportunity to the Eastern Shore!

Sincerely,

Erin Langley  
Executive & Artistic Director, Eastern Shore Repertory Theatre



CITY OF FAIRHOPE  
 P.O. DRAWER 429  
 FAIRHOPE, AL 36533  
 251/928-2136

Revised 09/2013

2/12/2021

Received  
 [Signature]

ALCOHOLIC BEVERAGE LICENSE APPLICATION

PLEASE PRINT

We hereby apply for a license to sell Alcoholic Beverages in the City of Fairhope or its Police Jurisdiction. We agree to abide by all applicable Ordinances of the City, or any amendments to same, and to promptly furnish all reports required by the City.

APPLICANT'S NAME Southern Chill, LLC SSN# \_\_\_\_\_

AGE \_\_\_\_\_ DATE OF BIRTH \_\_\_\_\_ PLACE OF BIRTH NEWARK, NJ

MAILING ADDRESS P.O. BOX 2001, FAIRHOPE, AL 36533

HOME # \_\_\_\_\_ WORK # 251-333-0211

CELL # \_\_\_\_\_ FAX # \_\_\_\_\_

RESIDENCE ADDRESS 314 DELAWARE AVE, APT 3, FAIRHOPE, AL 36532

NO. YEARS AT PRESENT ADDRESS 1 NO. YEARS AT PREVIOUS ADDRESS 2

PREVIOUS ADDRESS 4848 BERMUDA AVE, UNIT B2, SAN DIEGO, CA 92107

NAME AND ADDRESS OF BUSINESS SOUTHERN CHILL

P.O. BOX 2001, FAIRHOPE, AL 36533

NAME OF CORPORATION SOUTHERN CHILL, LLC

BUSINESS LOCATION 85 N. BANCROFT ST, FAIRHOPE, AL 36532

HAS APPLICANT EVER HAD AN ALCOHOLIC BEVERAGE LICENSE BEFORE NO

IF SO, WHERE \_\_\_\_\_ UNDER WHAT NAME \_\_\_\_\_

HAS APPLICANT EVER BEEN ARRESTED NO IF SO, WHERE \_\_\_\_\_

WHEN \_\_\_\_\_ WHAT WAS CHARGE \_\_\_\_\_

DISPOSITION EXCELLENT

LIST THREE REFERENCES:

NAME	ADDRESS	PHONE NUMBER
CHERYL VIEREGGER	314 DELAWARE AVE., AL	
DAVID BONING	10707 WOODRIDGE, VA	
KIP DYE	8150, CO RD 24, AL	

City of Fairhope  
Alcoholic Beverage  
License Application  
Page -2-

**PLEASE SELECT TYPE OF LICENSE APPLYING FOR:**

\_\_\_\_\_ 011 - PACKAGE STORE LICENSE – Allows sale of liquor, wine, or beer at Retail, TO GO only. No one under age 21 allowed on premises. A liquor tax of 10% City Limits or 5% Police Jurisdiction is due the 10<sup>th</sup> of each month on the purchase price paid for all liquor for use or resale by the licensee.

\_\_\_\_\_ 010- LOUNGE LIQUOR LICENSE – Allows sale of liquor, wine, or beer for on and off consumption. No one under age 21 allowed on the premises. A liquor tax of 10% City Limits or 5% Police Jurisdiction is due the 10<sup>th</sup> of each month on the purchase price paid for all liquor for use or resale by the licensee.

\_\_\_\_\_ 031- CLUB LIQUOR LICENSE – Allows sale of liquor, wine, or beer but must meet ABC Board's "club" regulations. A liquor tax of 10% City Limits or 5% Police Jurisdiction is due the 10<sup>th</sup> of each month on the purchase price paid for all liquor for use or resale by the licensee.

\_\_\_\_\_ 020 - RESTAURANT LIQUOR LICENSE – Allows sale of liquor, wine, or beer for on-premises consumption only and 51% of gross receipts must come from the sale of food. A liquor tax of 10% City Limits or 5% Police Jurisdiction is due the 10<sup>th</sup> of each month on the purchase price paid for all liquor for use or resale by the licensee.

\_\_\_\_\_ 140 - SPECIAL EVENTS LICENSE

160 - SPECIAL RETAIL LICENSE – More than 30 days

\_\_\_\_\_ 040 - BEER ON/OFF PREMISES LICENSE – Allows sale of Beer Only, on and off consumption.

\_\_\_\_\_ 050 - BEER OFF-PREMISES LICENSE – Allows sale of Beer Only, TO GO only.

\_\_\_\_\_ 060 - WINE ON/OFF PREMISES LICENSE – Allows sale of Wine Only, on and off consumption.

\_\_\_\_\_ 070 - WINE OFF-PREMISES LICENSE – Allows sale of Wine Only, TO GO, only.

\_\_\_\_\_ 100 - WINE WHOLESALER LICENSE

\_\_\_\_\_ 210 - WINE IMPORTER LICENSE

\_\_\_\_\_ 200 - WINE MANUFACTURER LICENSE

\_\_\_\_\_ 240 - NON-PROFIT TAX EXEMPT LICENSE

**I STATE ALL THE ABOVE TO BE TRUE AND CORRECT TO THE BEST OF MY KNOWLEDGE.**

Kim D. [Signature]  
SIGNATURE (FULL NAME)

02/09/2021  
DATE

NOT APPROVED \_\_\_\_\_ DATE \_\_\_\_\_  
Chief of Police

NOT APPROVED BY COUNCIL \_\_\_\_\_ DATE \_\_\_\_\_  
City Clerk

APPROVED [Signature] DATE 2/15/21  
Chief of Police

APPROVED BY COUNCIL \_\_\_\_\_ DATE \_\_\_\_\_  
City Clerk

\*\* The Chief of Police is only acquiring a background check on the owners, partners, or corporate officers of the business for the City of Fairhope. The Alabama Alcoholic Beverage Control Board does a thorough Federal and State background check before issuing the License.



**CITY OF FAIRHOPE**  
**P.O. DRAWER 429**  
**FAIRHOPE, AL 36533**  
**251/928-2136**

**ALCOHOLIC BEVERAGE LICENSE APPLICATION**

**PLEASE PRINT**

We hereby apply for a license to sell Alcoholic Beverages in the City of Fairhope or its Police Jurisdiction. We agree to abide by all applicable Ordinances of the City, or any amendments to same, and to promptly furnish all reports required by the City.

*David J. Jewett*

APPLICANT'S NAME *DeLons Play Time LLC* SSN# \_\_\_\_\_  
 AGE \_\_\_\_\_ DATE OF BIRTH \_\_\_\_\_ PLACE OF BIRTH *Wichita, Kansas*  
 MAILING ADDRESS *21780 Country Woods Fairhope, AL 36532*  
 HOME # \_\_\_\_\_ WORK # *251-990-9372*  
 CELL # *251-747-4883* FAX # \_\_\_\_\_  
 RESIDENCE ADDRESS *Same as Above*  
 NO. YEARS AT PRESENT ADDRESS *2* NO. YEARS AT PREVIOUS ADDRESS *2*  
 PREVIOUS ADDRESS *9130 City forrest, Fairhope, AL 36532*  
 NAME AND ADDRESS OF BUSINESS *Cafe 98*

NAME OF CORPORATION *DeLons Play Time LLC*  
 BUSINESS LOCATION *901 Fairhope Ave Fairhope AL 36532*  
 HAS APPLICANT EVER HAD AN ALCOHOLIC BEVERAGE LICENSE BEFORE *NO*  
 IF SO, WHERE \_\_\_\_\_ UNDER WHAT NAME \_\_\_\_\_  
 HAS APPLICANT EVER BEEN ARRESTED *NO* IF SO, WHERE \_\_\_\_\_  
 WHEN \_\_\_\_\_ WHAT WAS CHARGE \_\_\_\_\_  
 DISPOSITION \_\_\_\_\_

LIST THREE REFERENCES:

NAME	ADDRESS	PHONE NUMBER
<i>Dana Finley</i>	<i>709 Rosa Ave</i>	
<i>Bobby Jones</i>	<i>Stillmead, Ok</i>	
<i>Tim Kambach</i>	<i>9496 Hankoe Ln Fairhope, AL 36532</i>	

City of Fairhope  
Alcoholic Beverage  
License Application  
Page -2-

**PLEASE SELECT TYPE OF LICENSE APPLYING FOR:**

\_\_\_\_\_ **011 - PACKAGE STORE LICENSE** – Allows sale of liquor, wine, or beer at Retail, TO GO only. No one under age 21 allowed on premises. A liquor tax of 10% City Limits or 5% Police Jurisdiction is due the 10<sup>th</sup> of each month on the purchase price paid for all liquor for use or resale by the licensee.

\_\_\_\_\_ **010- LOUNGE LIQUOR LICENSE** – Allows sale of liquor, wine, or beer for on and off consumption. No one under age 21 allowed on the premises. A liquor tax of 10% City Limits or 5% Police Jurisdiction is due the 10<sup>th</sup> of each month on the purchase price paid for all liquor for use or resale by the licensee.

\_\_\_\_\_ **031- CLUB LIQUOR LICENSE** – Allows sale of liquor, wine, or beer but must meet ABC Board's "club" regulations. A liquor tax of 10% City Limits or 5% Police Jurisdiction is due the 10<sup>th</sup> of each month on the purchase price paid for all liquor for use or resale by the licensee.

✓ \_\_\_\_\_ **020 - RESTAURANT LIQUOR LICENSE** – Allows sale of liquor, wine, or beer for on-premises consumption only and 51% of gross receipts must come from the sale of food. A liquor tax of 10% City Limits or 5% Police Jurisdiction is due the 10<sup>th</sup> of each month on the purchase price paid for all liquor for use or resale by the licensee.

\_\_\_\_\_ **140 - SPECIAL EVENTS LICENSE**

\_\_\_\_\_ **160 - SPECIAL RETAIL LICENSE** – More than 30 days

\_\_\_\_\_ **040 - BEER ON/OFF PREMISES LICENSE** – Allows sale of Beer Only, on and off consumption.

\_\_\_\_\_ **050 - BEER OFF-PREMISES LICENSE** – Allows sale of Beer Only, TO GO only.

\_\_\_\_\_ **060 - WINE ON/OFF PREMISES LICENSE** – Allows sale of Wine Only, on and off consumption.

\_\_\_\_\_ **070 - WINE OFF-PREMISES LICENSE** – Allows sale of Wine Only, TO GO, only.

\_\_\_\_\_ **100 - WINE WHOLESALER LICENSE**

\_\_\_\_\_ **210 - WINE IMPORTER LICENSE**

\_\_\_\_\_ **200 - WINE MANUFACTURER LICENSE**

\_\_\_\_\_ **240 - NON-PROFIT TAX EXEMPT LICENSE**

**I STATE ALL THE ABOVE TO BE TRUE AND CORRECT TO THE BEST OF MY KNOWLEDGE.**

*David J. Hunt*  
SIGNATURE (FULL NAME)

7-11-2021  
DATE

NOT APPROVED \_\_\_\_\_ DATE \_\_\_\_\_  
Chief of Police

NOT APPROVED \_\_\_\_\_ DATE \_\_\_\_\_  
BY COUNCIL \_\_\_\_\_ City Clerk

APPROVED *[Signature]* DATE 2/15/21  
Chief of Police

APPROVED \_\_\_\_\_ DATE \_\_\_\_\_  
BY COUNCIL \_\_\_\_\_ City Clerk

\*\* The Chief of Police is only acquiring a background check on the owners, partners, or corporate officers of the business for the City of Fairhope. The Alabama Alcoholic Beverage Control Board does a thorough Federal and State background check before issuing the License.

# **ENVIRONMENTAL ADVISORY BOARD**

## **NOMINEE (S)**

**4 - Year Term**

### APPOINTMENTS

Jennifer Foutch

### REAPPOINTMENTS

Gary Gover

Mike Shelton

Jeanine Normand

The term shall end February 2025

# CITY OF FAIRHOPE



## APPLICATION FOR APPOINTMENT TO A CITY BOARD OR COMMITTEE

City Council seeks to have diversity in making appointment to boards and committees. It is the policy of the City Council to make appointments based on the needs of the City as well as the interests and qualifications of each applicant. In accordance with the Code of Alabama, all applicants must be qualified electors and taxpayers in the City, excluding the Planning Commission. All applications filed with the City Clerk will be public record.

Please return this application to the Fairhope City Clerk at City Hall, 161 North Section Street, Fairhope, Alabama 36532 or mail to City of Fairhope, Attention Fairhope City Clerk, P. O. Drawer 429, Fairhope, Alabama 36533. PLEASE PRINT CLEARLY

Last Name: **Foutch** First Name: **Jennifer** Phone Number: \_\_\_\_\_  
Cell: **618-318-0354** Email: **foutch.jennifer@gmail.com**  
Home Address: **526 Kensley Ave.**  
City: **Fairhope** State: **AL** Zip: **36532**  
Business Address: **23280 County Rd. 65**  
City: **Robertsdale** State: **AL** Zip: **36567**  
Name of Board or Committee: **Recycling Committee or Environmental Advisory Board**

### EDUCATIONAL BACKGROUND:

**Law Degree from Southern Illinois University School of Law - 1998**  
**Bachelor Degree from Southern Illinois University - 1995 (Major Criminal Justice/ Minor Political Science)**

### PROFESSIONAL LICENSES AND/OR ASSOCIATIONS:

**Licensed Attorney State of Alabama**  
**Licensed Attorney State of Illinois (Inactive Status)**  
**Baldwin County Bar Association**  
**Professional Standards Administrator - National Association of Realtors**

### PROFESSIONAL EXPERIENCE:

**I practiced criminal law for over 18 years in Illinois (1998-2016). I worked as an Assistant States Attorney for Perry County, IL for 12 years. I was then appointed as the Public Defender for Perry County, IL and served in that role for 6 years. In 2016, I re-located to Fairhope. I currently serve in the role of Government Affairs Director for the Baldwin Realtors Association, a position I have held since 2017. I also serve as the Professional Standards Administrator for the Baldwin Realtors Association, a role that helps enforce the Code of Ethics through the mediation/arbitration/hearing process.** +



CIVIC INTERESTS AND/OR SERVICE MEMBERSHIPS:

I serve as a representative of Baldwin Realtors Association on the Eastern Shore Chamber of Commerce Government & Political Affairs Committee. I currently serve on a national committee of the National Association of Realtors Committee on Property Rights and the Environment. I have a personal interest in promoting recycling and good stewardship of the environment.

HOW WILL YOUR QUALIFICATIONS BEST SERVE THE NEEDS OF THE COMMUNITY?

I would like to offer my legal background, analytical thinking, and personal interest in recycling to serve the community. My job as Government Affairs Director has allowed me to network with local governments and business leaders around Baldwin County and can help in collaboration.

Signature:  Date: 11/18/20

You may attach a resume with this application.

## **Lisa A. Hanks, MMC**

---

**From:** Kim Burmeister  
**Sent:** Monday, February 15, 2021 7:47 AM  
**To:** Lisa A. Hanks, MMC  
**Cc:** Gary Gover; Corey Martin  
**Subject:** FEAB Motions passed on 2/12 regarding membership

Lisa Corey: How soon can we get this on Council? This is from my minutes draft for the February FEAB meeting, which I will forward to you both shortly.

### **FEAB Attendance / membership:**

1. Gary: Per Lisa Hanks there is a requirement to have FEAB members reappointed every four years. These members are overdue for renewal/reappointment: Tony Pritchett, Gary Gover, Mike Shelton and Jeanine Normand. Tony has resigned via email. Gary opened a motion to renew Gover, Shelton and Normand. Michelle seconded the motion. Unanimously approved
2. Since Tony Pritchett has resigned, this leaves FEAB membership at eight, with one vacancy.
3. Gary made a motion to accept Jennifer's Foutch's membership appointment. Michelle seconded the motion. Unanimously approved.
4. **MOTIONS APPROVED:**
  - a. **Renew 4-year appointment for Gover, Shelton and Normand**
  - b. **Accept Jennifer Foutch as new member to FEAB**

Kim Burmeister  
City of Fairhope  
Planning and Zoning Department  
Code Enforcement Officer  
251 990-2877

**BOARD OF ADJUSTMENTS  
& APPEALS**

**NOMINEE (S)**

**3-Year Term**

APPOINTMENTS

---

REAPPOINTMENTS

---

David Martin – 1st Alternate Member

Donna Cook – 2nd Alternate Member

The terms shall end February 2024 for Alternate Members

# CITY OF FAIRHOPE



## APPLICATION FOR APPOINTMENT TO A CITY BOARD OR COMMITTEE

City Council seeks to have diversity in making appointment to boards and committees. It is the policy of the City Council to make appointments based on the needs of the City as well as the interests and qualifications of each applicant. In accordance with the Code of Alabama, all applicants must be qualified electors and taxpayers in the City, excluding the Planning Commission. All applications filed with the City Clerk will be public record.

Please return this application to the Fairhope City Clerk at City Hall, 161 North Section Street, Fairhope, Alabama 36532 or mail to City of Fairhope, Attention Fairhope City Clerk, P. O. Drawer 429, Fairhope, Alabama 36533.

PLEASE PRINT CLEARLY

Last Name: Martin First Name: David

Phone Number: 251 370-4657 Cell: \_\_\_\_\_ Email: \_\_\_\_\_

Home Address: 19060 Scenic Hwy 98

City: Fairhope State: AL Zip: 36532

Business Address: \_\_\_\_\_

City: \_\_\_\_\_ State: \_\_\_\_\_ Zip: \_\_\_\_\_

Name of Board or Committee: Board of Adjustments

### EDUCATIONAL BACKGROUND:

Bachelors of Science - Springhill College

### PROFESSIONAL LICENSES AND/OR ASSOCIATIONS:

Alabama General Contractor and Home Builder's License

### PROFESSIONAL EXPERIENCE:

See resume

### CIVIC INTERESTS AND/OR SERVICE MEMBERSHIPS:

See resume

### HOW WILL YOUR QUALIFICATIONS BEST SERVE THE NEEDS OF THE COMMUNITY?

As a contractor and previous member of the planning commission, I would like to think that I can help our community to continue growing in a positive nature

Signature: [Handwritten Signature]

Date: 7/25/19

You may attach a resume with this application.

**DAVID D. MARTIN, IV**  
19060 Scenic Highway 98 | Fairhope, AL 36532  
Home: (251) 928-2591 | Cell: (251) 370-4657  
[martin2591@att.net](mailto:martin2591@att.net)

---

Self-motivated, professional able to work in teams and lead independently. Career of over 30 years in the field of general contracting, construction management and consulting which has instilled a strong background in all aspects of business. Possess the ability to develop client relationships and trust through hard work and determination. Result oriented, problem solver and adapts well to changing environments. Definitive organizational skills which allows for successful multi-tasking across and within a variety of projects.

## SKILLS

---

- |                             |                        |                          |                             |
|-----------------------------|------------------------|--------------------------|-----------------------------|
| • Division Management       | • Logistics            | • Web Based Software     | • Budgeting & Cost Controls |
| • Operations Management     | • Estimating           | • Microsoft Applications | • OSHA Compliance           |
| • Senior Project Management | • Scheduling           | • Adobe                  | • Accounting                |
|                             | • Sales & Negotiations | • Sure-Track             | • Finance                   |
|                             | • General Supervision  | • CAD                    |                             |

## PROFESSIONAL EXPERIENCE

---

### **Managing Member - SCC Group, I.L.C, 2009 to Present**

Directing the daily operations for a general contracting and consulting firm that has a range of clients in the southeast. Duties included the negotiation of projects, scheduling, estimating, project management, financial reviews and running due diligence on various companies. Focused on quality work, client satisfaction, maintaining schedules, logistics, and open communication.

#### **Key Achievements:**

- Have grown the customer base by 100% per year
- Client satisfaction exhibited by 90% repeat business

### **Operations/Senior Manager - Thomas Industries, 2007 to 2009**

Joined the company to help grow their general contracting division by implementing new procedures in estimating, management, field supervision, and marketing. Analyzed operations to evaluate performance and make necessary changes. Reviewed all areas for program improvement, policy change and cost efficiency

#### **Key Achievements:**

- Grew the division by 800%
- Hired 50% of the companies personnel to accommodate the growth
- Built a new and viable infrastructure which increased profits

### **Area Manager/Senior Manager/Senior Estimator /Superintendent - Brasfield & Gorrie, LLC (Various Locations), 1995-2007**

Directed field operations on an area basis, reviewed drawings and specifications, managed safety and work force, preformed work in a logical sequence, and obtained all necessary permits. Estimated and directed young estimators in the means in methods of estimating, scheduling techniques, subcontractor and vendor solicitation, sales and negotiations. Managed several projects at a time by coordinating the work, scheduling, logistics, writing contracts and purchase orders, and built long lasting relations with owners, vendors and subcontractors. Managed the south Alabama area and oversaw estimating, management and superintendents while selling and negotiating work.

**Key Achievements:**

- Built a state of the art, 450,000sf hospital within 2-1/2 years
- Estimated, bought-out and managed a state of the art science building that was completed with-in 13 months which led to 2 more years of work on the campus
- Opened and ran a satellite office that grew to \$150 million per year within 3 years

**EDUCATION & CERTIFICATIONS**

---

- **Leadership Certificate, 2014**  
Springhill College
- **Bachelors of Science, 1995**  
Springhill College
- **General Contractors License**  
AL and approved for GA, LA, MS, NC, SC, TN, AR
- **OSHA 30-Hour**

**TRADE & CIVIC RESPONSIBILITIES**

---

- **Associated Builders and Contractors** (1995-2009)  
(1998-2010, Mobile, AL Board Member 2005-2010, Vice President 2010)
- **Fairhope Planning Commission** (2016-2017)
- **Association of General Contractors** (1998-2010)
- **Youth Soccer Coach** (2006-2015)
- **Ducks Unlimited** (1995-2009, Events Committee 2006-2009)
- **Coastal Conservation Association**

JUL 6 '20 at 3:16

ZAH

# CITY OF FAIRHOPE



## APPLICATION FOR APPOINTMENT TO A CITY BOARD OR COMMITTEE

City Council seeks to have diversity in making appointment to boards and committees. It is the policy of the City Council to make appointments based on the needs of the City as well as the interests and qualifications of each applicant. In accordance with the Code of Alabama, all applicants must be qualified electors and taxpayers in the City, excluding the Planning Commission. All applications filed with the City Clerk will be public record.

Please return this application to the Fairhope City Clerk at City Hall, 161 North Section Street, Fairhope, Alabama 36532 or mail to City of Fairhope, Attention Fairhope City Clerk, P. O. Drawer 429, Fairhope, Alabama 36533.

PLEASE PRINT CLEARLY

Last Name: COOK First Name: DONNA

Phone Number: 251-510-8885 Cell: SAME Email: 1FAIRHOPE@9H.NET

MAILING. Home Address: PO Box 1092 Point Clear AL 36564 / 209 SEMINOLE AVE

City: FAIRHOPE State: AL Zip: 36532 FAIRHOPE AL

Business Address: 205 FAIRHOPE AVE

City: FAIRHOPE State: AL Zip: 36532

Name of Board or Committee: BOARD OF ADJUSTMENTS

### EDUCATIONAL BACKGROUND:

3 YEARS COLLEGE  
REAL ESTATE BROKER

### PROFESSIONAL LICENSES AND/OR ASSOCIATIONS:

REAL ESTATE BROKER LICENSE

### PROFESSIONAL EXPERIENCE:

24 YEARS REAL ESTATE IN FAIRHOPE AL.  
OWNER/BROKER OF BALDWIN COUNTY PROPERTIES

### CIVIC INTERESTS AND/OR SERVICE MEMBERSHIPS:

FEFF, EASTER SHORE ART CENTER, E.S. CHAMBER OF COMMERCE  
REALTOR.

### HOW WILL YOUR QUALIFICATIONS BEST SERVE THE NEEDS OF THE COMMUNITY?

FAIR & HONEST WITH BUILDING KNOWLEDGE

Signature: Donna Cook Date: 6/29/20

You may attach a resume with this application.