

**CITY OF FAIRHOPE  
CITY COUNCIL WORK SESSION AGENDA**

**THURSDAY, 23 FEBRUARY 2017 – 4:30 P.M. – COUNCIL CHAMBERS**

1. 2016 Comprehensive Annual Financial Report
2. Moratorium Update
3. Committee Updates
4. Department Head Updates

**Next Regular Meeting Thursday, March 9, 2017 Same Time and Place**

**CITY OF FAIRHOPE  
CITY COUNCIL AGENDA  
THURSDAY, 23 FEBRUARY 2017 - 6:00 P.M. - CITY COUNCIL CHAMBER**

**Invocation and Pledge of Allegiance**

1. Approve Minutes of 13 February 2017 Regular City Council Meeting, minutes of 13 February 2017 Work Session, and minutes of 13 February 2017 Agenda Meeting.
2. Report of the Mayor
3. Public Participation – Agenda Items
4. Council Comments
5. **Final Adoption** – Ordinance – Amend Zoning Ordinance No. 1253.  
Request to rezone the property of Cliff Pitman from RA Residential/Agriculture District to R-2 Medium Density Single Family Residential District This property is generally located at 19940 County Road 13, Fairhope, Alabama. Parcel No. 05-46-05-22-0-000-001.565. (Introduced at the February 13, 2017 City Council Meeting)
6. Resolution – That the 15’ Utility Easement currently existing on the lot line between Lot 35 and lot 36, Greystone Subdivision, Silverhill, Alabama as referenced in attached “Exhibit A,” be declared surplus with the understanding that those two lots have been joined into one lot by the owner of said property, and the utility easements will still exist along the lot lines of the new lot created by the joining of Lot 35 and Lot 36; and that Mayor Karin Wilson is hereby authorized to execute a Quit Claim Deed from the City of Fairhope to Frank Leatherwood and Jennifer Coleman Leatherwood for the aforementioned Utility Easement.
7. Resolution – That the City of Fairhope has voted to purchase Lighting System for Tennis Center for the Recreation Department and the requested item is available for direct procurement through the National Joint Powers Alliance (“NJPA”) Buying Group Contract; and therefore does not have to be let out for bid. The total cost is \$129,900.00. This has been nationally bid through the NJPA’s bid process.
8. Resolution – That the City of Fairhope approves the Adult League Rules and Code of Conduct; and the Adult League Fees for the Mike Ford Tennis Center for Fairhope Municipal Tennis Courts as proposed by the Recreation Board.
9. Resolution – That the City of Fairhope approves the procurement of Neptune Gas Meter ERTS for the Gas Department for the fiscal year 2017, to be purchased as needed from Consolidated Pipe & Supply Co., Inc. as Sole Source Provider in the State of Alabama for Neptune Technology Group, Inc. The units must fit into our existing standardized system; and are exempt from formal bid pursuant to Code of Alabama 1975, Section 41-16-51(b)(7). The estimated number of units is 466 ERTS at \$75.00 per unit at a not to exceed annual cost of \$35,000.00.
10. Site Plan Review – Request of Chris Haley on behalf of William Haas, for approval for Portico, a 56-unit project – located at the northeast corner of Fairhope Avenue and Brown Street.

11. Request to Approve allocating a full-time police officer as a School Resource Officer using the two trained officers when needed to fill the position; and to Approve a new position of Police Officer for the Police Department with a Pay Grade of 21 (beginning at \$20.00 and APOST certified).
12. Application for a Non-Profit Tax Exempt License (Alcoholic Beverage License) by Blair Bullen for the American Cancer Society, Inc., for The Black Out Ball located at 161 North Section Street, Fairhope, Alabama on March 31, 2017 from 6:30 p.m. to 11:00 p.m.
13. Public Participation
14. Adjourn

**City Council Work Session - 4:30 p.m.  
on Thursday, February 23, 2017 – Council Chambers**

**City Council Agenda Meeting - 5:30 p.m.  
on Thursday, February 23, 2017 – Council Chambers**

**Next Regular Meeting – Thursday, March 9, 2017 - Same Time and Place**

STATE OF ALABAMA            )  
  :  
COUNTY OF BALDWIN        )

The City Council, City of Fairhope, met in regular session at 6:00 p.m., Fairhope Municipal Complex Council Chamber, 161 North Section Street, Fairhope, Alabama 36532, on Monday, 13 February 2017.

Present were Council President Jack Burrell, Councilmembers: Jay Robinson, Jimmy Conyers, Robert Brown, and Kevin Boone, Mayor Karin Wilson, City Attorney Marion E. Wynne, and City Clerk Lisa A. Hanks.

There being a quorum present, Council President Burrell called the meeting to order. The invocation was given by Reverend William Parsons, Pastor of Redeemer Lutheran Church, and the Pledge of Allegiance was recited. Councilmember Boone moved to approve minutes of the 23 January 2017, regular meeting; minutes of the 23 January 2017, work session; and minutes of the 23 January 2017, agenda meeting. Seconded by Councilmember Conyers, motion passed unanimously by voice vote.

Mayor Wilson addressed the City Council and mentioned the first Town Hall Meeting which will be focused on the First 90 Days of being in Office and Looking Forward. She also mentioned the Team Building Retreat scheduled for March 20, 2017; will have the review of her proposed budget in a few weeks.

Mayor Wilson presented a Proclamation to Pat Lee who founded Children of the World here in Fairhope; and declared Saturday, February 4, 2017 as Children of the World Day. Mayor Wilson said Children of the World is internationally known and will be celebrating its 20th anniversary. She said Ms. Lee is an amazing woman and has been responsible for an incredible amount of adoptions; right at 2,000.

The following individuals spoke during Public Participation for Agenda Items:

- 1) Ron Allen, 6612 Willow Bridge Drive, addressed the City Council regarding Agenda Items No.12 and No. 13: a resolution to award bid for Sludge Removal Services for the Waste Water Treatment Plant; and a resolution that the City Council approves the selection of Goodwyn Mills Cawood, Inc. to perform Professional Architectural Services for Repairs to Library Structure. Mr. Allen requested to state how many cubic yards of sludge is being removed; and what structural repairs will be done at the library.

Councilmember Robinson recognized the Tree Committee and the City for Arbor Day which was a great event.

Councilmember Conyers thanked the Tree Committee for his business receiving an award and reminded everyone of the upcoming Mardi Gras parades.

13 February 2017

Councilmember Brown also mentioned the kickoff of Mardi Gras. He thanked Sherry Sullivan and Tom Kuhl for the Manley Road Soccer Complex. Councilmember Brown read the following letter to the City Council:

I want to address recent online blogs and other issues people have approached me about in recent weeks. Several of our Councilmen have been accused of being privy to information because of positions they serve in. Just because they are privy to information doesn't mean they have shared that information or that they are corrupt. When I see comments on social media asking what are the other Councilmembers' positions on items involving the Airport Authority, my first thought is why I am wasting my time on social media. My second is I am not going to get in a debate on social media. For several reasons; the main reason is my perspective. You can't tell whether someone is angry, asking a serious question or just trying to get people roused up. Call me, my number is available, and I will personally take your call.

As I mentioned campaigning, I am going to make my decisions based on facts and what I believe is best for the City of Fairhope as a whole. That means listening to those who don't show up voicing their opinions in public; some who are third or fourth generation Fairhophians.

I have lived in Fairhope for the last 33 years minus military service and time at Auburn. It is a matter of time before I will be labeled a good ole boy. By the nature of living here for over three decades I have crossed paths with many people; both through business and socially. I will recommend and vote for some of these people and their businesses. Does that mean I am corrupt because I recommended someone I trust?

As the City leaders, we must hold everyone accountable and make sure the correct process is followed in every circumstance. It is also our job to move the City forward in a positive direction. You can be part of the problems or part of the solutions. That's your choice. But me personally, I am looking forward not backwards; and will pray on every decision before I make it.

In closing I want to say, myself along with the other four Councilmen and Mayor Wilson were elected to serve all of Fairhope. If you agree or disagree with what is being done in our town, I encourage you to let us know. Call me; don't ask me on social media because I won't take that call.

Councilmember Boone commented he attended the Library's Chocolate and Champagne Event which was a great event; and encouraged everyone to attend next year's event.

Council President Burrell said he also attended both the Arbor Day Celebration and the Chocolate and Champagne Event. He stated these were both great events for the City; and told everyone to go out and enjoy the City.

13 February 2017

A Public Hearing was held as advertised on a proposed ordinance to Amend Zoning Ordinance No. 1253. Councilmember Conyers introduced an ordinance to rezone the property of Cliff Pitman from RA Residential/Agriculture District to R-2 Medium Density Single Family Residential District. This property is generally located at 19940 County Road 13, Fairhope, Alabama. Parcel No. 05-46-05-22-0-000-001.565. The Planning Commission gave a favorable recommendation of this ordinance. Councilmember Brown recused himself from this agenda item.

Council President Burrell read the proposed ordinance. Planning Director Wayne Dyess briefly explained the proposed ordinance.

Council President Burrell opened the Public Hearing at 6:16 p.m. No one present opposed the proposed ordinance, the Public Hearing closed at 6:17 p.m.

Due to lack of a motion for immediate consideration, this ordinance will layover until the February 23, 2017 City Council meeting.

Councilmember Conyers introduced in writing, and moved for the adoption of the following resolution, a resolution that Mayor Karin Wilson is hereby authorized to approve Amendment No. 1 to the Contract for Professional Engineering Services, for RFQ No. PS001-17 (Project No. PW001-17) for Fly Creek Marina Seawall Improvements 2017, with FMS Engineering Services, Inc., at a cost of the amendment not to exceed \$3,800.00. Seconded by Councilmember Boone, motion passed unanimously by voice vote.

**RESOLUTION NO. 2675-17**

**BE IT RESOLVED BY THE GOVERNING BODY OF THE CITY OF FAIRHOPE, ALABAMA,** that Mayor Karin Wilson is hereby authorized to approve Amendment No. 1 to the Contract for Professional Engineering Services, for RFQ No. PS001-17 (Project No. PW001-17) for Fly Creek Marina Seawall Improvements 2017, with FMS Engineering Services, Inc., at a cost of the amendment not to exceed \$3,800.00.

DULY ADOPTED THIS 13TH DAY OF FEBRUARY, 2017

\_\_\_\_\_  
Karin Wilson, Mayor

Attest:

\_\_\_\_\_  
Lisa A. Hanks, MMC  
City Clerk

13 February 2017

Councilmember Conyers introduced in writing, and moved for the adoption of the following resolution, a resolution that Mayor Karin Wilson is hereby authorized to approve Amendment No. 1 to the Contract for Professional Engineering Services, for RFQ No. PS008-17, On-call for Planning Department Projects, with S.E. Civil Engineering, LLC, at a cost of the amendment not to exceed \$15,000.00. The motion was seconded by Councilmember Robinson. Planning Director Wayne Dyess explained the need for extending this contract partly due to moratorium issues. Building Official Erik Cortinas stated we use Larry Smith with S. E. Civil Engineering, LLC to help with reviews. Councilmember Brown stated in the future, he wants to track these annually. After further discussion, motion passed unanimously by voice vote.

**RESOLUTION NO. 2676-17**

**BE IT RESOLVED BY THE GOVERNING BODY OF THE CITY OF FAIRHOPE, ALABAMA**, that Mayor Karin Wilson is hereby authorized to approve Amendment No. 1 to the Contract for Professional Engineering Services, for RFQ No. PS008-17, On-call for Planning Department Projects, with S.E. Civil Engineering, LLC, at a cost of the amendment not to exceed \$15,000.00.

DULY ADOPTED THIS 13TH DAY OF FEBRUARY, 2017

---

Karin Wilson, Mayor

Attest:

---

Lisa A. Hanks, MMC  
City Clerk

Councilmember Conyers introduced in writing, and moved for the adoption of the following resolution, a resolution to Award Bid for Lift Station Odor Control Chemicals for the Sewer Department (Bid No. 008-17) with an annual cost of \$224,475.00. Seconded by Councilmember Boone, motion passed unanimously by voice vote.

13 February 2017

**RESOLUTION NO. 2677-17**

**BE IT RESOLVED BY THE GOVERNING BODY OF THE CITY OF FAIRHOPE, ALABAMA**, as follows:

[1] That the City of Fairhope did request, receive, and open a bid for Lift Station Odor Control Chemicals for the Sewer Department (Bid Number 008-17) at 555 South Section Street in the City of Fairhope offices, Fairhope, Alabama.

[2] At the appointed time and place, the following bids were opened and tabulated as follows:

Please see attached Bid Tabulation for  
Lift Station Odor Control Chemicals for the Sewer Department

[3] After evaluating the bid proposals with the required bid specifications, Biomagic, Inc., with the total bid proposal of \$6.00 per metered gallon, for an annual cost of \$224,475.00, is now awarded the bid for Lift Station Odor Control Chemicals for the Sewer Department.

Adopted on this 13th day of February, 2017

\_\_\_\_\_  
Karin Wilson, Mayor

Attest:

\_\_\_\_\_  
Lisa A. Hanks, MMC  
City Clerk

\*

\*

\*

\*



13 February 2017

CITY OF FAIRHOPE  
 BID TABULATION and Recommendation  
 BID NO: 008-17  
 BID NAME: LIFT STATION ODOR CONTROL CHEMICAL  
 BID OPENED: January 24, 2017 10:00 a.m.  
 Note: Bid Bond REQUIRED

| VENDOR                                | BID BOND SUBMITTED | Addenda 1 & 2 | Bid Proposal Executed / Signed / Notarized | COST PER METERED GALLON | DOLLARS PER SITE PER YEAR | ANNUAL TOTAL         |
|---------------------------------------|--------------------|---------------|--|-------------------------|---------------------------|----------------------|
| <b>BioMagic, Inc.</b>                 | yes                | yes           | yes  |                         |                           | <b>\$224,475.00</b>  |
| Twin Beech PS                         |                    |               |  | \$6.00                  | \$37,230.00               |                      |
| Carya Point PS                        |                    |               |  | \$6.00                  | \$4,380.00                |                      |
| Woodlands PS                          |                    |               |  | \$6.00                  | \$32,850.00               |                      |
| Quail Creek PS #1                     |                    |               |  | \$6.00                  | \$28,470.00               |                      |
| East of the Sun PS                    |                    |               |  | \$6.00                  | \$15,330.00               |                      |
| White Grove PS                        |                    |               |  | \$6.00                  | \$15,330.00               |                      |
| Thompson Hall PS                      |                    |               |  | \$6.00                  | \$26,280.00               |                      |
| Grand Hotel PS                        |                    |               |  | \$6.00                  | \$21,900.00               |                      |
| Baldwin 1 PS                          |                    |               |  | \$6.00                  | \$10,950.00               |                      |
| Point Clear Court PS                  |                    |               |  | \$6.00                  | \$10,950.00               |                      |
| Southland Place PS                    |                    |               |  | \$6.00                  | \$9,855.00                |                      |
| Rohr Street                           |                    |               |  | \$6.00                  | \$10,950.00               |                      |
| <b>Evoqua Water Technologies, LLC</b> | yes                | yes           | yes  |                         |                           | <b>\$ 364,166.70</b> |
| Twin Beech #1                         |                    |               |  | \$5.71                  | \$56,696.20               |                      |
| Carya Point PS                        |                    |               |  | \$5.71                  | \$9,377.50                |                      |
| Woodlands PS                          |                    |               |  | \$5.71                  | \$55,624.54               |                      |
| Quail Creek PS #1                     |                    |               |  | \$5.71                  | \$29,853.54               |                      |
| East of the Sun PS                    |                    |               |  | \$5.71                  | \$37,329.68               |                      |
| White Grove PS                        |                    |               |  | \$5.71                  | \$12,247.80               |                      |
| Thompson Hall PS                      |                    |               |  | \$5.71                  | \$46,362.28               |                      |
| Grand Hotel PS                        |                    |               |  | \$5.71                  | \$58,760.76               |                      |
| Baldwin 1 PS                          |                    |               |  | \$5.71                  | \$6,858.66                |                      |
| Point Clear Court                     |                    |               |  | \$5.71                  | \$3,827.38                |                      |
| Southland Place                       |                    |               |  | \$5.71                  | \$29,879.05               |                      |
| Rohr PS Street                        |                    |               |  | \$5.71                  | \$19,349.51               |                      |
| <b>USP Technologies, LLC</b>          |                    |               |  |                         |                           | <b>NO BID</b>        |
| Twin Beech #1                         |                    |               |  |                         |                           |                      |
| Carya Point PS                        |                    |               |  |                         |                           |                      |
| Woodlands PS                          |                    |               |  |                         |                           |                      |
| Quail Creek PS #1                     |                    |               |  |                         |                           |                      |
| East of the Sun PS                    |                    |               |  |                         |                           |                      |
| White Grove PS                        |                    |               |  |                         |                           |                      |
| Thompson Hall PS                      |                    |               |  |                         |                           |                      |
| Grand Hotel PS                        |                    |               |  |                         |                           |                      |
| Baldwin 1 PS                          |                    |               |  |                         |                           |                      |
| Point Clear Court                     |                    |               |  |                         |                           |                      |
| Southland Place                       |                    |               |  |                         |                           |                      |
| Rohr PS Street                        |                    |               |  |                         |                           |                      |

13 February 2017

|                                    |             |  |  |  |  |
|------------------------------------|-------------|--|--|--|--|
| Thornton, Musso, Bellamin          | no response |  |  |  |  |
| US Water Services, Inc.            | no response |  |  |  |  |
| US Filter Company, Inc             | no response |  |  |  |  |
| Water and Waste Specialties, LLC   | no response |  |  |  |  |
| ChemStation Gulf Coast             | no response |  |  |  |  |
| Industrial Chemical                | no response |  |  |  |  |
| PENCCO, Inc                        | no response |  |  |  |  |
| F2 Industries, LLC                 | no response |  |  |  |  |
| DPC Enterprises                    | no response |  |  |  |  |
| Norit Americas, Inc.               | no response |  |  |  |  |
| J.H. Wright & Associates, Inc.     | no response |  |  |  |  |
| North American Commercial          | no response |  |  |  |  |
| Kemper Industries, Inc.            | no response |  |  |  |  |
| ACT Specialty Chemicals, Inc.      | no response |  |  |  |  |
| North American MANTEK              | no response |  |  |  |  |
| Thatcher Chemical of Florida       | no response |  |  |  |  |
| Water Treatment & Controls Company | no response |  |  |  |  |
| ALTIVA Chemicals                   | no response |  |  |  |  |
| NRP Group, Inc.                    | no response |  |  |  |  |
| Harrington Industrial Plastics     | no response |  |  |  |  |

RECOMMENDATION: Award Bid to BioMagic, Inc. in the amounts listed above.

 1/25/17  
 Dan McCrory  
 Superintendent Water and Sewer  
 City of Fairhope

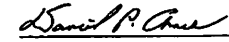
 1/25/17  
 Daniel P. Ames, Purchasing Manager  
 Purchasing Manager  
 City of Fairhope

Councilmember Robinson introduced in writing, and moved for the adoption of the following resolution, a resolution that the City of Fairhope has voted to purchase 25,000 feet of 2-inch Gas Pipe for the Gas Department; and authorizes procurement based on the option allowed by the Code of Alabama 1975, Section 41-16-51(b)(7) to obtain quotes. The total cost will be \$16,494.75. Seconded by Councilmember Conyers, motion passed unanimously by voice vote.

13 February 2017

**RESOLUTION NO. 2678-17**

**BE IT RESOLVED BY THE GOVERNING BODY OF THE CITY OF FAIRHOPE, ALABAMA**, as follows:

[1] That the City of Fairhope has voted to purchase 25,000 feet of 2-inch Gas Pipe for the Gas Department; and authorizes procurement, from Southern Pipe & Supply, Inc. based on the option allowed by the Code of Alabama 1975, Section 41-16-51(b)(7) to obtain quotes. The total cost will be \$16,494.75.

Adopted on this 13th day of February, 2017

\_\_\_\_\_  
Karin Wilson, Mayor

Attest:

\_\_\_\_\_  
Lisa A. Hanks, MMC  
City Clerk

Councilmember Conyers introduced in writing, and moved for the adoption of the following resolution, a resolution that Mayor Karin Wilson is hereby authorized to execute Extension No. 1 of the Contract with Galls, LLC for the Police Department Uniforms 2016 (Bid Number 019-16) for an additional one year as per the terms and conditions of the original contract. The approximate annual cost will be \$13,000.00. Seconded by Councilmember Boone, motion passed unanimously by voice vote.

**RESOLUTION NO. 2679-17**

**BE IT RESOLVED BY THE GOVERNING BODY OF THE CITY OF FAIRHOPE, ALABAMA**, that Mayor Karin Wilson is hereby authorized to execute Extension No. 1 of the Contract with Galls, LLC in Lexington, KY for the Police Department Uniforms 2016 (Bid Number 019-16) for an additional one year as per the terms and conditions of the original contract. The approximate annual cost will be \$13,000.00.

Adopted on this 13th day of February, 2017

\_\_\_\_\_  
Karin Wilson, Mayor

Attest:

\_\_\_\_\_  
Lisa A. Hanks, MMC  
City Clerk

13 February 2017

Councilmember Robinson introduced in writing, and moved for the adoption of the following resolution, a resolution to Award RFQ for Resurfacing Fairhope Library Entrance Walkway 2017 for the Fairhope Public Library (Project No. PW008-17), with a total proposal of \$16,261.50. The motion was seconded by Councilmember Conyers. Councilmember Brown explained the issue at the Library with the slate; and this is more durable than what is there now. Purchasing Manager Dan Ames commented that this is a non-skid surface. After further discussion, motion passed unanimously by voice vote.

**RESOLUTION NO. 2680-17**

**BE IT RESOLVED BY THE GOVERNING BODY OF THE CITY OF FAIRHOPE, ALABAMA, as follows:**

[1] That the City of Fairhope did request and receive RFQs for Resurfacing Fairhope Library Entrance Walkway 2017, (Project No. PW008-17) at 555 South Section Street in the City of Fairhope offices, Fairhope, Alabama.

[2] At the appointed time and place, the following RFQs were received and tabulated as follows:

|                                |             |
|--------------------------------|-------------|
| Renu Hard Surface Restorations | \$16,261.50 |
| A+ Concrete Designs, LLC       | \$17,321.00 |

[3] At the appointed time and place; after evaluating the RFQ proposal with the required specifications, Renu Hard Surface Restorations, LLC, of Fairhope, AL, with a total proposal of \$16,261.50, is now awarded the RFQ for Resurfacing Fairhope Library Entrance Walkway 2017.

Adopted on this 13th day of February, 2017

\_\_\_\_\_  
Karin Wilson, Mayor

Attest:

\_\_\_\_\_  
Lisa A. Hanks, MMC  
City Clerk

13 February 2017

Councilmember Robinson introduced in writing, and moved for the adoption of the following resolution, a resolution to Award Bid for Sludge Removal Services for the Waste Water Treatment Plant (Bid No. 010-17), with a total bid proposal of \$85.00 per cubic yard. Seconded by Councilmember Brown, motion passed unanimously by voice vote.

**RESOLUTION NO. 2681-17**

**BE IT RESOLVED BY THE GOVERNING BODY OF THE CITY OF FAIRHOPE, ALABAMA, as follows:**

[1] That the City of Fairhope did request, receive, and open bids for Sludge Removal Services for the Waste Water Treatment Plant (Bid Number 010-17) at 555 South Section Street in the City of Fairhope offices, Fairhope, Alabama.

[2] At the appointed time and place, the following bids were opened and tabulated as follows:

|                           |                        |
|---------------------------|------------------------|
| GreenSouth Solutions, LLC | \$85.00 per Cubic Yard |
| AmWaste, LLC              | No Response            |

[3] After evaluating the bid proposals with the required bid specifications, Green South Solutions LLC, with the total bid proposal of \$85.00 per cubic yard, is now awarded the bid for Sludge Removal Services for the Waste Water Treatment Plant.

Adopted on this 13th day of February, 2017

---

Karin Wilson, Mayor

Attest:

---

Lisa A. Hanks, MMC  
City Clerk

Councilmember Brown introduced in writing, and moved for the adoption of the following resolution, a resolution that the City Council approves the selection of Goodwyn Mills Cawood, Inc. to perform Professional Architectural Services for (Project No. PW007-17) Repairs to Library Structure 2017, and hereby authorizes Mayor Karin Wilson to negotiate a fee schedule, and establish a not-to-exceed figure. The motion was seconded by Councilmember Conyers. Purchasing Manager Ames and Jim Walker with Goodwyn Mills and Cawood explained there would be three components being testing, design, and construction administration. After further discussion, motion passed unanimously by voice vote.

13 February 2017

**RESOLUTION NO. 2682-17**

**BE IT RESOLVED BY THE GOVERNING BODY OF THE CITY OF FAIRHOPE, ALABAMA**, that the City Council approves the selection of Goodwyn Mills Cawood, Inc. to perform Professional Architectural Services for (Project No. PW007-17) Repairs to Library Structure 2017, and hereby authorizes Mayor Karin Wilson to negotiate a fee schedule, and establish a not-to-exceed figure.

DULY ADOPTED THIS 13TH DAY OF FEBRUARY, 2017

\_\_\_\_\_  
Karin Wilson, Mayor

Attest:

\_\_\_\_\_  
Lisa A. Hanks, MMC  
City Clerk

Councilmember Conyers introduced in writing, and moved for the adoption of the following resolution, a resolution that Mayor Karin Wilson is hereby authorized to execute and Extension of Agreement concerning Tolling of the Statute of Limitations between the Utilities Board of the City of Daphne and the City of Fairhope regarding jointly owned gas lines. Seconded by Councilmember Robinson, motion passed unanimously by voice vote.

**RESOLUTION NO. 2683-17**

**WHEREAS**, the City Council adopted Resolution No. 2634-16 on December 12, 2016 which authorized the execution of the Agreement concerning Tolling of the Statute of Limitations between the Utilities Board of the City of Daphne and the City of Fairhope regarding jointly owned gas lines;

**WHEREAS**, Fairhope and Daphne Utilities desire to extend the Tolling Agreement an additional ninety (90) days.

**NOW THEREFORE BE IT RESOLVED BY THE GOVERNING BODY OF THE CITY OF FAIRHOPE, ALABAMA**, that Mayor Karin Wilson is hereby authorized to execute an Extension of Agreement concerning Tolling of the Statute of Limitations between the Utilities Board of the City of Daphne and the City of Fairhope regarding jointly owned gas lines.

Adopted on this 13th day of February, 2017

\_\_\_\_\_  
Karin Wilson, Mayor

Attest:

\_\_\_\_\_  
Lisa A. Hanks, MMC  
City Clerk

13 February 2017

Councilmember Conyers introduced in writing, and moved for the adoption of the following resolution, a resolution that Mayor Karin Wilson is hereby authorized to execute a Contract for Professional IT Services for the Police Department with Elias Technologies, a/k/a Cyber Forensics 360, with a cost not to exceed \$35,000.00. Seconded by Councilmember Robinson, motion passed unanimously by voice vote.

**RESOLUTION NO. 2684-17**

**BE IT RESOLVED BY THE GOVERNING BODY OF THE CITY OF FAIRHOPE, ALABAMA**, that Mayor Karin Wilson is hereby authorized to execute a Contract for Professional IT Services for the Police Department with Elias Technologies, a/k/a Cyber Forensics 360, with a cost not to exceed \$35,000.00.

DULY ADOPTED THIS 13TH DAY OF FEBRUARY, 2017

---

Karin Wilson, Mayor

Attest:

---

Lisa A. Hanks, MMC  
City Clerk

Building Official Erik Cortinas explained the need for an additional Building Inspector position for current employee after filling the position of Planning Director. Council President Burrell stated this position is in the prior proposed budget as well as the Mayor's proposed budget to come. Councilmember Conyers moved to grant the request to approve a new position of Building Inspector for the Building Department with a Pay Grade of 21 (\$35,000.00 annually depending on qualifications). Seconded by Councilmember Robinson, motion passed unanimously by voice vote.

City Council reviewed an application for a Restaurant Liquor License by Fish River Grill by the Bay, LLC, located at 9270 Scenic Hwy 98, Fairhope, Alabama. Councilmember Robinson moved to approve the issuance of the license. Seconded by Councilmember Conyers, motion passed unanimously by voice vote.

13 February 2017

City Council reviewed an application for a Restaurant Liquor License by Chive Talk'n Catering, LLC, located at 556 South Section Street, Fairhope, Alabama moving to 821 South Mobile Street, Fairhope, Alabama. Councilmembers Brown and Boone recused themselves. Councilmember Conyers moved to approve the issuance of the license. Seconded by Councilmember Robinson, motion passed by the following voice votes: AYE – Burrell, Robinson, and Conyers. NAY – None. ABSTAIN – Brown and Boone.

City Council reviewed an application for a Restaurant Liquor License by Agnes Henry Hospitality, LLC, d/b/a Fairhope's Grill and Bar, located at 210 Eastern Shore Shopping Center, Fairhope, Alabama. Councilmember Boone moved to approve the issuance of the license. Seconded by Councilmember Conyers, motion passed unanimously by voice vote.

Councilmember Conyers moved to appoint Tennant McWilliams (Class I) and Susan McWilliams (Class III) and to reappoint Ed Lamonte and Cindy Wilson (both Class III) to the Sister Cities Committee. Class I term will expire in February 2020 and Class III term will expire in February 2019. Seconded by Councilmember Boone, motion passed unanimously by voice vote.

The following individuals spoke during Public Participation:

- 1) Dean Mosher, 456 Oak Avenue, addressed the City Council regarding his request to present a Power Point Presentation and twice was denied. He gave out a handout with questions to the City Council regarding the Airport Authority.
- 2) Councilmember Robinson announced the Downtown Business Association will be hosting its first annual Block Party on Fairhope Avenue between Section Street and Church Street from 2:00 p.m. to 4:00 p.m.
- 3) Paul Ripp, 22985 High Ridge Road, addressed the City Council regarding the request to repeal the Fly Creek Ordinance; Public Figure Doctrine, and social media won the election.
- 4) Reverend Larry Williams, 623 Middle Street, addressed the City Council regarding citizens feeding cats in his neighborhood. He requested the City Council look into this issue.

At the request of the City Attorney, Marion E. Wynne, the City Council will rise from the meeting to go into Executive Session based on Section 36-25A-7(a)(3) to discuss the legal ramifications of and legal options for pending litigation. The approximate time to be in Executive Session is 30 minutes. Councilmember Robinson moved to go into Executive Session. Seconded by Councilmember Boone, motion passed unanimously by voice vote.

Exited the dais at 6:52 p.m. Returned at 7:53 p.m.



13 February 2017

Councilmember Robinson moved to adjourn the meeting. Seconded by Councilmember Boone, motion passed unanimously by voice vote.

There being no further business to come before the City Council, the meeting was duly adjourned at 7:53 p.m.

---

Jack Burrell, Council President

---

Lisa A. Hanks, MMC  
City Clerk

STATE OF ALABAMA                    )(  
  :  
COUNTY OF BALDWIN                )(

The City Council met in a Work Session at 4:30 p.m.,  
Delchamps Room, 161 North Section Street,  
161 North Section Street, Fairhope, Alabama 36532, on  
Monday, 13 February 2017.

Present were Council President Jack Burrell, Councilmembers: Jay Robinson, Jimmy Conyers, Robert Brown, and Kevin Boone, Mayor Karin Wilson, City Attorney Marion E. Wynne, and City Clerk Lisa A. Hanks.

Council President Burrell called the meeting to order at 4:30 p.m.

The following topics were discussed:

- The Fairhope Single Tax Corporation – Tatumville Development was the first item on the agenda. Trey Jinright presented the site plan for the 12 lot subdivision and the gulley property owned by the City of Fairhope. The proposed plan would put the detention pond, a park with step pools, and low impact development techniques. This would become a demonstration project for the City of Fairhope. The Fairhope Single Tax Corporation would pay for the project with an estimated cost of \$300,000.00 to \$400,000.00. Lee Turner, Chair of FSTC, said this would give the City a nature park for the neighborhood and community.

Mayor Wilson commented that Tatumville Gulley needs help; and the City would ultimately have liability in the future not the 12 homeowners. She asked if the FSTC would take over the watershed. Mr. Turner replied that 10 acres would be corrected and stabilized. Councilmember Brown questioned with a 10 lot subdivision if the detention pond would be on FSTC property. Council President Burrell also questioned where detention pond would be located. Mr. Jinright commented the project would stop at Lot 22 for improvements and retention pond; and this project would be done correctly. He said you know when you are holding water and when you are releasing water.

Councilmember Conyers stated this is a really great project, but my concern as a Councilmember is for water retention being on City property; we should have a third party review. Three options were giving by FSTC: partner with City and put detention pond on City property with 12 lot subdivision; partner with City and put detention pond on FSTC property with 10 lot subdivision; or sell property and another developer build. Councilmember Brown commented if we don't partner with FSTC another developer could build. Councilmember Boone recused himself due to being a FSTC member.

Dean Mosher, 456 Oak Avenue, addressed the City Council and stated the most critical watershed in Fairhope is Tatumville with a 45 foot drop. If developed the gulley will washout, undermine, and the park would be located in a flood zone. He said you have a third option: give the property to the City and not develop; and leave the gulley alone and give the money for the Library repairs.

- The Recreation Board's Five Year Plan was presented next by Bob Keyser. He explained and discussed the main priorities to the City Council:
  1. Complete an engineering study of Volanta
  2. Refurbish the visitors concession stands at Majors Field
  3. Renovate Volanta Park consistent with results of the engineering study
  4. Complete a Master Plan for the buildout of the municipal pool
  5. Implement Phase I of the municipal pool master plan
  6. Repairs and Improvements to Founders Park Softball Complex
  7. Prepare a Master Plan for growth of Disc Golf
  8. Develop a Master Plan for Colony Nature Park
  9. Expand the Barnwell concession stand
  10. Add a new racquetball court at the Recreation Center
  11. Implement recommendations of Colony Nature Park
  12. Construct an Olympic-size swimming pool (50m x 25 yds) with diving well adjacent to the existing indoor pool

Councilmember Brown commented field space is needed and will be needed at the ballparks. Council President Burrell asked about studies being done for finances and priorities. Councilmember Robinson stated this takes a lot of work and time from the Recreation Board to put this 5-Year Plan together.

Council President Burrell asked about lights for the clay tennis courts. Community Affairs and Recreation Director stated the lights are in the budget with an estimated cost of \$125,000.00. Council President Burrell requested this item be placed on the next City Council agenda.

- Councilmember Conyers said he attended the Library's Chocolate and Champagne Event. He went to the Fairhope Environmental Advisory Board and they are looking into having a "Clean Marina" designation; the Historic Preservation Committee is still working on whether or not to present an ordinance to form a Historic Commission.
- Councilmember Robinson said the Tree Committee put on Arbor Day this past Saturday and was told it was a great event. He mentioned the Recycling Committee.
- Councilmember Brown stated that the Education Advisory Committee has been reviewing the principals' proposal; however, the main issue and priority is hiring School Resource Officers. Council President Burrell commented there may be a possibility for funds. He said there is drug used in both the Middle School and High School; and meetings were held at schools with key people and all are on board with this idea. Council President Burrell said we are looking at the fees collected through our Court; and to see if we can fund the Magistrate's salaries through the Court. Then, we could use the funds for a Resource Officer.

Councilmember Brown commented we need to move on that issue as soon as possible. He stated the Pedestrian and Bicycle Committee have been looking for places in the City for bike racks.

- Councilmember Boone mentioned the Personnel Board had a special-called meeting to meet the Mayor. He announced the next meeting is scheduled for February 23, 2017 at 7:15 a.m. The Harbor Board has been working on the seawall project at the marina.
- Council President Burrell said the Industrial Development Board met and one of the main topics is what to do with the light industrial park on Nichols. One of the ideas is to form an Entrepreneurial Area. He said the Airport Authority is still working on refinancing the property.
- Recreation Director Tom Kuhl addressed the City Council and said his department has been getting ready for the spring activities.
- Planning Director Wayne Dyess addressed the City Council and said that his department has been working on moratorium items and moving forward.
- Economic and Community Development Director Sherry-Lea Botop addressed the City Council and stated she has been working on data gathering; and will soon present to the City Council what her department will be doing.
- Public Works Director Jennifer Fidler addressed the City Council and thanked Council President Burrell for handing out trees on Arbor Day. Ms. Fidler said that her department is preparing for Mardi Gras; and will help with barricades using contract labor.
- Chief Chris Ellis addressed the City Council and commented last month was a busy month for the Fire Department with over 100 calls.

There being no further business to come before the City Council, the meeting was duly adjourned at 5:49 p.m.

---

Jack Burrell, Council President

---

Lisa A. Hanks, MMC  
City Clerk

STATE OF ALABAMA            )(  
  :  
COUNTY OF BALDWIN        )(

The City Council met in an Agenda Meeting at 5:30 p.m.,  
Fairhope Municipal Complex Council Chamber,  
161 North Section Street, Fairhope, Alabama 36532,  
on Monday, 13 February 2017.

Present were Council President Jack Burrell, Councilmembers: Jay Robinson, Jimmy Conyers, Robert Brown, and Kevin Boone, Mayor Karin Wilson, City Attorney Marion E. Wynne, and City Clerk Lisa A. Hanks.

Council President Burrell called the meeting to order at 5:49 p.m. The City Council reviewed and discussed the agenda for their meeting to be held today at 6:00 p.m.

There being no further business to come before the City Council, the meeting was duly adjourned at 5:50 p.m.

---

Jack Burrell, Council President

---

Lisa A. Hanks, MMC  
City Clerk

ORDINANCE NO. \_\_\_\_

**AN ORDINANCE AMENDING ORDINANCE NO. 1253  
KNOWN AS THE ZONING ORDINANCE**

BE IT ORDAINED BY THE CITY COUNCIL OF THE CITY OF FAIRHOPE, ALABAMA as follows:

The ordinance known as the Zoning Ordinance (No. 1253), adopted 27 June 2005, together with the Zoning Map of the City of Fairhope, be and the same hereby is changed and altered in respect to that certain property described below:

After the appropriate public notice and hearing of the Planning Commission of the City of Fairhope, Alabama has forwarded a favorable recommendation,

The property of Cliff Pitman generally located at 19940 County Road 13, Fairhope, Alabama.

**TAX PARCEL 05-46-05-22-0-000-001.565**

**Legal Description:** (Case number ZC 16.09)

COMMENCE AT A RAILROAD SPIKE AT THE NORTHWEST CORNER OF SECTION 22, TOWNSHIP 6 SOUTH, RANGE 2 EAST, BALDWIN COUNTY, ALABAMA AND RUN THENCE SOUTH 00 DEGREES 26 MINUTES 31 SECONDS WEST, ALONG THE WEST LINE OF SAID SECTION, A DISTANCE OF 240.05 FEET; THENCE RUN SOUTH 89 DEGREES 33 MINUTES 04 SECONDS EAST, A DISTANCE OF 33.00 FEET TO A REBAR FOUND ON THE EAST MARGIN OF BALDWIN COUNTY HIGHWAY 13 FOR A POINT OF BEGINNING; THENCE CONTINUE SOUTH 89 DEGREES 33 MINUTES 04 SECONDS EAST, A DISTANCE OF 1282.05 FEET TO A CAPPED REBAR; THENCE RUN SOUTH 00 DEGREES 24 MINUTES 47 SECONDS WEST, A DISTANCE OF 424.05 FEET TO A CRIMP TOP IRON PIPE; THENCE RUN NORTH 89 DEGREES 37 MINUTES 44 SECONDS WEST, A DISTANCE OF 1282.72 FEET TO A CAPPED REBAR ON THE AFOREMENTIONED EAST MARGIN OF BALDWIN COUNTY HIGHWAY 13; THENCE RUN NORTH 00 DEGREES 30 MINUTES 11 SECONDS EAST, ALONG SAID EAST MARGIN, A DISTANCE OF 425.79 FEET TO THE POINT OF BEGINNING. TRACT CONTAINS 12.51 ACRES, MORE OR LESS, AND LIES IN THE NORTHWEST QUARTER OF SECTION 22, TOWNSHIP 6 SOUTH, RANGE 2 EAST, BALDWIN COUNTY, ALABAMA.

A map of the property to be zoned is attached as Exhibit A

**The property is hereby rezoned from RA Residential / Agriculture District to R-2 Medium Density Single Family Residential District.** This property shall hereafter be lawful to construct on such property any structures permitted by Ordinance No. 1253 and to use said premises for any use permitted or building sought to be erected on said property shall be in compliance with the building laws of the City of Fairhope and that any structure shall be approved by the Building Official of the City of Fairhope and that any structure be erected only in compliance with such laws, including the requirements of Ordinance No. 1253.

**Severability Clause** - if any part, section or subdivision of this ordinance shall be held unconstitutional or invalid for any reason, such holding shall not be construed to invalidate or impair the remainder of this ordinance, which shall continue in full force and effect notwithstanding such holding.

**Effective Date** – This ordinance shall take effect immediately upon its due adoption and publication as required by law.

ADOPTED THIS 23RD DAY OF FEBRUARY, 2017

\_\_\_\_\_  
Karin Wilson, Mayor

ATTEST:

\_\_\_\_\_  
Lisa A. Hanks, MMC  
City Clerk



**CITY OF FAIRHOPE  
CITY COUNCIL COVER SHEET**

**December 14, 2016**

|                 |   |
|-----------------|---|
| <b>ZC 16.09</b> | <b>Public Hearing to consider the request of Dewberry/Preble-Rish, LLC to rezone property from RA Residential/Agriculture District to R-2 Medium Density Single Family Residential District. The property is located on the east side of County Road 13, just south of Pecan Park, at 19940 County Road 13.</b> |
|-----------------|---|

**STAFF INTERPRETATION:**

The subject property is currently zoned R-A (Residential/Agriculture District). The applicant wishes to rezone the property to R-2 (Medium Density Single Family Residential District). The total area of the property is approximately 12.51 acres.

Mr. Cliff Pittman is the property owner. If rezoned, the owner plans on adding a future phase to the Fox Hollow Subdivision.

The property is bordered to the north by R-6 (Mobile Home Park District) property, to the south and west by R-2 and un-zoned property in Baldwin County, and to the east by property zoned R-2.

The request does not appear to be contrary to the City's Comprehensive Plan or the criteria in the Zoning Ordinance for a Zoning Amendment (Article II, Section C. (1) – Zoning Amendments). The request is consistent with what the City has approved in the area in previous years.

If the property is brought before the Planning Commission for subdivision in the future, all applicable regulations shall apply.

**STAFF RECOMMENDATION:**

On November 10, 2016 the Planning Commission unanimously recommended the City Council approve the proposed zoning change from R-A to R-2.

Respectfully Submitted for Consideration,

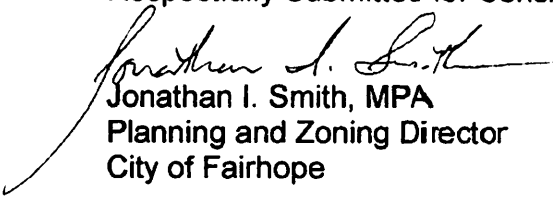
  
Jonathan I. Smith, MPA  
Planning and Zoning Director  
City of Fairhope





**APPLICATION FOR ZONING DISTRICT CHANGE**

**Property Owner / Leaseholder Information**

Name: CLIFF PITMAN Phone Number: 928-4052  
 Street Address: 9320 GAYFER AVENUE  
 City: FAIRHOPE State: AL Zip: 36532

**Applicant / Agent Information**

If different from above.  
 Notarized letter from property owner is required if an agent is used for representation.

Name: DEWBERRY/PREBLE-RISH Phone Number: 251-990-9950  
 Street Address: 9949 BELLATON AVENUE  
 City: DAPHNE State: AL Zip: 36526

Current Zoning of Property: R-A  
 Proposed Zoning/Use of the Property: R-2 SINGLE-FAMILY  
 Property Address: \_\_\_\_\_  
 Parcel Number: 05-46-05-22-D-000-001.565  
 Property Legal Description: SEE ATTACHED  
 Reason for Zoning Change: PROPOSED EXTENSION TO THE FOX HOLLOW DEVELOPMENT.

- Property Map Attached  YES  NO  
 Metes and Bounds Description Attached  YES  NO  
 Names and Address of all Real Property Owners within 300 Feet of Above Described Property Attached.  YES  NO

Character of Improvements to the Property and Approximate Construction Date: \_\_\_\_\_  
PROPOSED INFRASTRUCTURE FOR SINGLE FAMILY DEVELOPMENT.  
APPROXIMATE CONSTRUCTION DATE - 2017

Zoning Fee Calculation:  
 Reference: Ordinance 1269

I certify that I am the property owner/leaseholder of the above described property and hereby submit this application to the City for review. \*If property is owned by Fairhope Single Tax Corp. an authorized Single Tax representative shall sign this application.

CLIFF PITMAN  
 Property Owner/Leaseholder Printed Name  
09.26.16  
 Date

[Signature]  
 Signature  
[Signature]  
 Fairhope Single Tax Corp. (If Applicable)

RECEIVED  
 SEP 27 2016  
 EB

The Planning Commission met Monday, November 10, 2016 at 5:00 PM at the City Municipal Complex, 161 N. Section Street in the Council Chambers.

Present: Lee Turner, Chairperson; George Roberds, Vice-Chair; Ralph Thayer; Jennifer Fidler; Bob Clark; Bernie Fogarty; David Martin; Hollie MacKellar; Jimmy Conyers; Jonathan Smith, Planning Director; Emily Boyett, Secretary; and Tut Wynne, City Attorney

Absent: None

Chairman Turner called the meeting to order at 5:02 PM and announced the meeting is being recorded. Mr. Turner welcomed Dr. Thayer, Mr. Martin, and Councilman Conyers to the Planning Commission.

The minutes of the October 3, 2016 meeting were considered and George Roberds moved to accept the minutes as written and was 2<sup>nd</sup> by Bob Clark. The motion carried with the following abstentions: Ralph Thayer, Jennifer Fidler, Bernie Fogarty, David Martin, and Jimmy Conyers.

X

**ZC 16.09 Public hearing to consider the request of Dewberry/Preble-Rish, LLC to rezone property from RA Residential/Agriculture District to R-2 Medium Density Single Family Residential District, Steve Pumphrey.** The property is located on the east side of County Road 13, just south of Pecan Park, at 19940 County Road 13. Mr. Smith gave the staff report saying the property is approximately 12.51 acres and if rezoned the property owner plans on adding a future phase to the Fox Hollow subdivision. Staff recommendation is to approve the proposed zoning change from RA to R-2.

Mr. Pumphrey addressed the Commission saying the site would provide an access to County Road 13 for the Fox Hollow subdivision if it is rezoned.

Mr. Turner opened the public hearing. Having no one present to speak, Mr. Turner closed the public hearing.

Jennifer Fidler made a motion to accept the staff recommendation to approve the proposed zoning change from RA to R-2. Bernie Fogarty 2<sup>nd</sup> the motion and the motion carried unanimously.

David Martin recused himself and left the room.

**SD 16.21 Request of St. Lucia Properties, LLC for Multiple Occupancy Project approval of St. Lucia Cottages, a 3-unit project, Jeremy Lee.** The property is located on the west side of S. Mobile Street, just south of Fels Avenue, at 206 S. Mobile Street. Mr. Smith gave the staff report saying the property is located in the City of Fairhope and is zoned B-3a Tourist Resort Lodging District. The site is approximately .27 acres and 3 units are proposed. Due to the small size of the site the applicant is requesting a waiver to the LID requirements. Staff recommendation is to approve contingent upon the following conditions:

1. The Operations and Maintenance Plan and Agreement shall be revised and resubmitted, and recorded within 60 days, if approved.

# ZC 16.09 19940 County Road 13

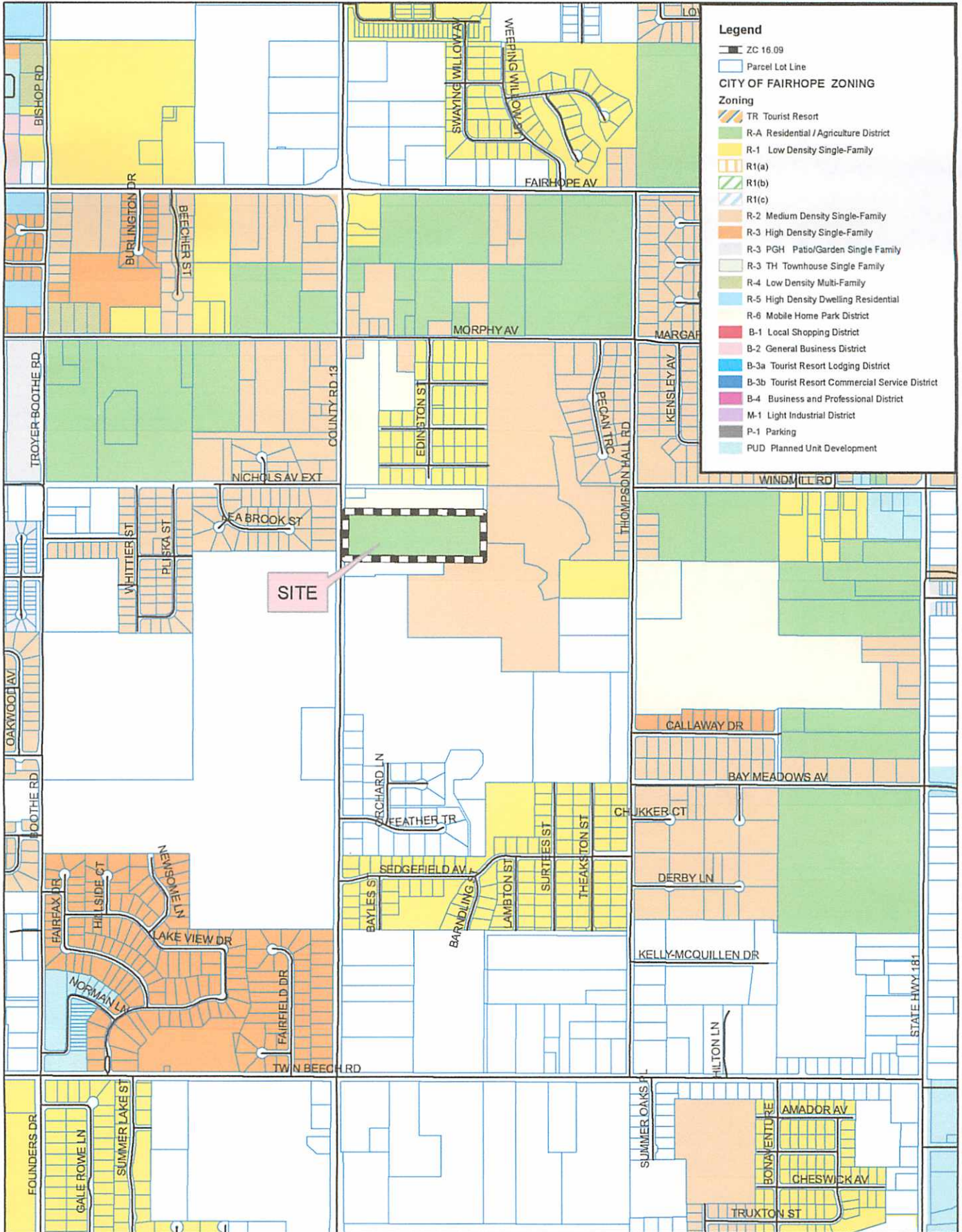

ZC 16.09 19940 County Road 13  
 Parcel No.: 05-46-05-22-0-00-001.565





ZC 16.09 19940 County Road13

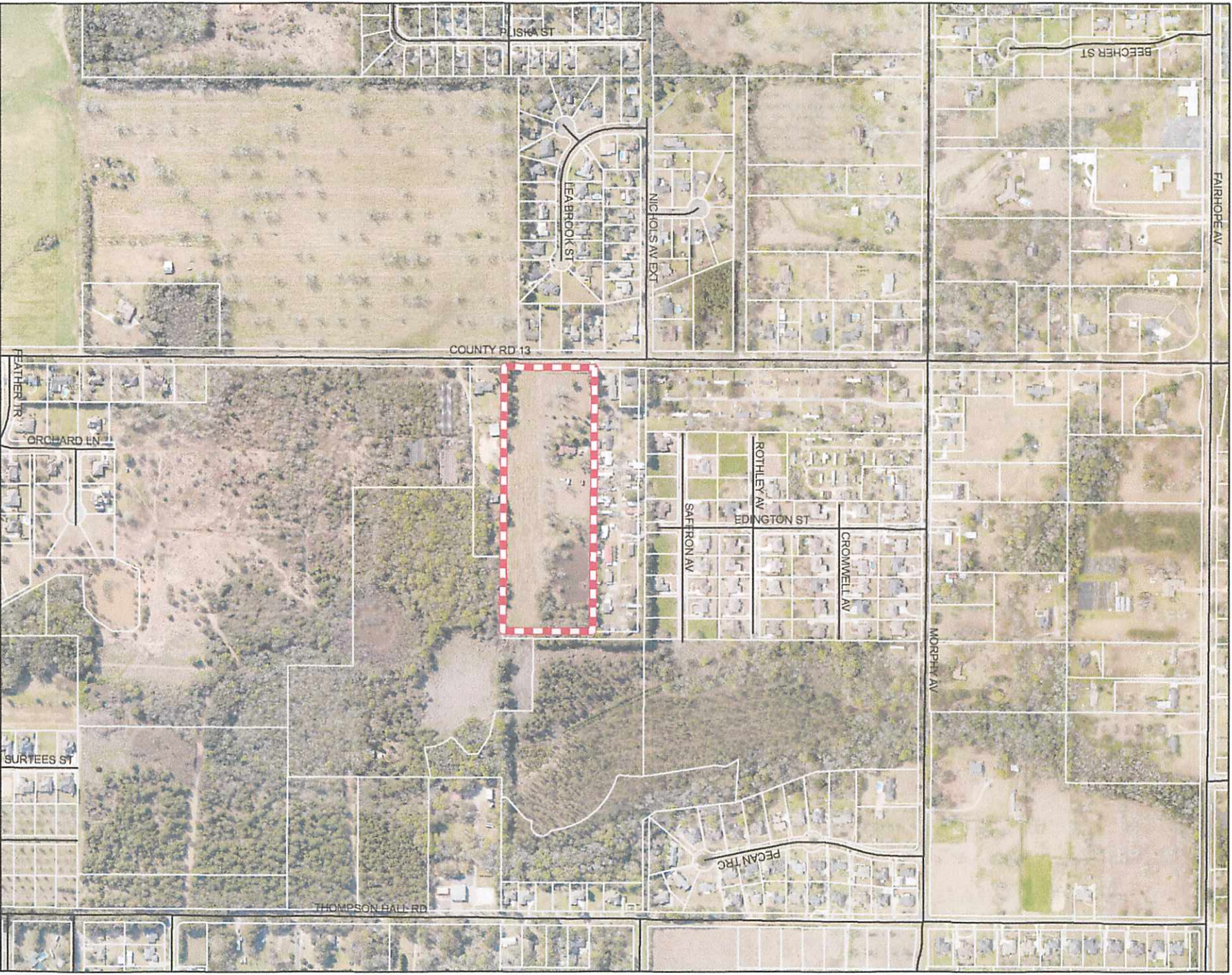

ZC 16.09 19940 County Road 13  
Parcel No.: 05-46-05-22-0-00-001.565



**RESOLUTION NO. \_\_\_\_\_**

**BE IT RESOLVED BY THE GOVERNING BODY OF THE CITY OF FAIRHOPE**, that the 15' Utility Easement currently existing on the lot line between Lot 35 and lot 36, Greystone Subdivision, Silverhill, Alabama as referenced in attached "Exhibit A," be declared surplus with the understanding that those two lots have been joined into one lot by the owner of said property, and the utility easements will still exist along the lot lines of the new lot created by the joining of Lot 35 and Lot 36; and that Mayor Karin Wilson is hereby authorized to execute a Quit Claim Deed from the City of Fairhope to Frank Leatherwood and Jennifer Coleman Leatherwood for the aforementioned Utility Easement.

Adopted on this 23rd day of February, 2017

\_\_\_\_\_  
Karin Wilson, Mayor

Attest:

\_\_\_\_\_  
Lisa A. Hanks, MMC  
City Clerk



**RESOLUTION NO. \_\_\_\_\_**

**BE IT RESOLVED BY THE GOVERNING BODY OF THE CITY OF FAIRHOPE, ALABAMA, as follows:**

[1] That the City of Fairhope has voted to purchase Lighting System for Tennis Center for the Recreation Department and the requested item is available for direct procurement through the National Joint Powers Alliance (“NJPA”) Buying Group Contract; and therefore does not have to be let out for bid. The total cost is \$129,900.00. This has been nationally bid through the NJPA’s bid process.

Adopted on this 23rd day February, 2017

\_\_\_\_\_  
Karin Wilson, Mayor

Attest:

\_\_\_\_\_  
Lisa A. Hanks, MMC  
City Clerk

City of Fairhope  
Project Funding Request

FEB 20 '17 AM 11:12

Issuing Date 2/16/2017

Please return this Routing Sheet to Treasurer by

2/16/2017

Project Name: Procure Lighting System for Tennis Center

Project Location: Mike Ford Tennis Center

Presented to City Council: 2/23/2017 Approved \_\_\_\_\_ Changed \_\_\_\_\_ Rejected \_\_\_\_\_

Project Cash Requirement Submitted for Approval: Cost: \$129,900.00  
from the NJPA Buying Group

Providers: Musco Sports Lighting, LLC  
Oskaloosa, IA

Project Engineer: n/a

Order Date: \_\_\_\_\_ Lead Time: n/a

| Department Funding This Project |     |          |       |       |         |            |    |        |
|---------------------------------|-----|----------|-------|-------|---------|------------|----|--------|
| General                         | Gas | Electric | Water | Sewer | Gas Tax | Cap. Proj. | XX | Impact |
|                                 |     |          |       |       |         |            |    |        |

| Division of General Fund Funding This Project |           |         |        |                 |           |  |  |
|---|-----------|---------|--------|-----------------|-----------|--|--|
| Admin 10                                      | Police 15 | Fire 20 | Rec 25 | Adult Rec 30    | Street 35 |  |  |
|   |           |         |        |                 |           |  |  |
|   | San 40    | Golf 50 |        | Debt Service 85 |           |  |  |

Expense Code 103-55851 Revenue Code \_\_\_\_\_

Project will be: Expensed xx  
Capitalized \_\_\_\_\_

Project Financed By:  
Grant: \_\_\_\_\_ Federal - not to exceed amount  
\_\_\_\_\_ State  
\_\_\_\_\_ City

Project Budgeted: \_\_\_\_\_  
In the proposed 2017 budget

(Over) Under budget amount: \_\_\_\_\_

Bond: \_\_\_\_\_ Title \_\_\_\_\_ Year \_\_\_\_\_  
Loan: \_\_\_\_\_ Title \_\_\_\_\_ Year \_\_\_\_\_  
Capital Lease: \_\_\_\_\_ Payment \_\_\_\_\_ Term \_\_\_\_\_

Funding: Capital project funds

|                                    |                  |                                      |                      |
|------------------------------------|------------------|--------------------------------------|----------------------|
| City Council prior approval        | <u>n/a</u>       | Request approved by City Treasurer   | <u>Richard Smith</u> |
| Request received by City Treasurer | <u>2/16/2017</u> | Request approved by Finance Director | <u>see below</u>     |
| Received by Finance Department     | <u>2/17/17</u>   | Request approved by Mayor            | <u>[Signature]</u>   |
| Received by Mayor                  | _____            |                                      |                      |

Contact Person: Sherry Sullivan





# MEMO

To: Deborah Smith, Treasurer  
From: *Daniel P. Ames*  
Daniel P. Ames, Purchasing Manager

Date: February 16, 2017

Re: Request Green Sheet and City Council approvals for procurement of Lighting System for Tennis Center for the Recreation Department.

The Recreation Department has requested the procurement of a lighting system for the Tennis Center. Utilizing our access to national buying groups competitive bids, quotations were sought.

The Recreation Department, recommends acquiring the lighting system. The total cost of the procurement will be One Hundred Twenty Nine Thousand Nine Hundred Dollars (\$129,900.00), through the NJPA buying group, from Musco Sports Lighting, LLC, of Oskaloosa, IA, (see attached quotation).

|             |                     |
|-------------|---------------------|
| List Price: | \$142,292.00        |
| NJPA Price: | <u>\$129,900.00</u> |
| Savings:    | \$ 10,392.00        |

Lead time is: Approximately 4 to 6 weeks, ARO. F.O.B. delivered.

**Please compose a greensheet and move forward for Council approval, this procurement request for one (1) Lighting System, for the Recreation Dept., Tennis Center, in the amount of One Hundred Twenty Nine Thousand Nine Hundred Dollars (\$129,900.00), through the NJPA buying group, from Musco Sports Lighting, LLC, of Oskaloosa, IA,**

Cc, file

Karin Wilson  
Mayor

*Council Members*

Kevin G. Boone

Robert A. Brown

Jack Burrell, ACOMO

Jimmy Conyers

Jay Robinson

Lisa A. Hanks, MMC  
City Clerk

Deborah A. Smith, CPA  
City Treasurer

161 North Section Street

P.O. Drawer 429

Fairhope, Alabama 36533

251-928-2136

251-928-6776 Fax

www.fairhopeal.gov

Printed on recycled paper



Fairhope Tennis Complex  
Fairhope, AL  
Date:  
February 15, 2017

**NATIONAL JOINT POWERS ALLIANCE**

Master Project: 170558

Contract Number: 082114-msl

Expiration: 09/16/2018

Category: Facility & MRO

Sub-Category: Athletic Field / Court and Parking Lot Lighting Systems

**Quotation Price- Materials Only**

---

|   |           |
|---|-----------|
| Musco's TLC 1150 LED Lighting System as described and delivered to the job..... | \$142,292 |
| Musco NJPA State of Alabama Purchasing Cooperative Discount .....               | \$ 10,392 |
| Final Fairhope Tennis materials Price.....                                      | \$129,900 |

*Sales tax, if applicable, is not included as part of this quote.*

*Pricing furnished is effective for 60 days unless otherwise noted and is considered confidential.*

**Equipment Description**

- 
- Musco's TLC 1150 LED System delivered to your site in Five Easy Pieces™
- (6) Pre-cast concrete bases
  - (6) Galvanized steel poles
  - UL Listed remote electrical component enclosures
  - Pole length wire harnesses
  - Factory-aimed and assembled luminaires

Also Includes:

- Energy savings of more than 50% over a standard lighting system
- 50% less spill and glare light than Musco's prior industry leading technology
- Musco Constant 25™ product assurance and warranty program that eliminates 100% of your maintenance costs for 25 years, including labor and materials
- Guaranteed constant light level of 30 footcandles for 25 years
- Reduced energy consumption
- Control Link® Control & Monitoring System for flexible control and solid management of your lighting system
- Lighting Contactors sized for voltage and phase on site

**Payment Terms to be determined between Musco Credit department and purchasing entity**

---

Upon Acceptance Email or fax a copy of the Purchase Order to Musco Sports Lighting:

Musco Sports Lighting, LLC  
Att: Jimmy Jumper  
Fax: 800-374-6402  
Email: Jimmy.jumper@musco.com

**All purchase orders and/or Musco PA's should note the following:**

**NJPA Purchase  
Master Project # 170558  
Contract #: 082114-MSL  
Musco Project #164362**

Delivery to the job site from the time of order, submittal approval, and confirmation of order details including voltage and phase, pole locations is approximately 4-6 weeks. Due to the built-in custom light control per luminaire, pole locations need to be confirmed prior to production. Changes to pole locations after the product is sent to production could result in additional charges.

**Notes**

---

Quote is based on:

- Shipment of entire project together to one location
- Structural code and wind speed = 2009 IBC, 140 MPH, Exposure C.
- Confirmation of pole locations prior to production

Thank you for considering Musco for your sports-lighting needs. Please contact me with any questions.

Jimmy Jumper  
Musco Sports Lighting, LLC  
Phone: 256-483-5433  
E-mail: jimmy.jumper@musco.com

## TLC for LED™ – Galvanized Steel Pole

**5 Easy Pieces™**

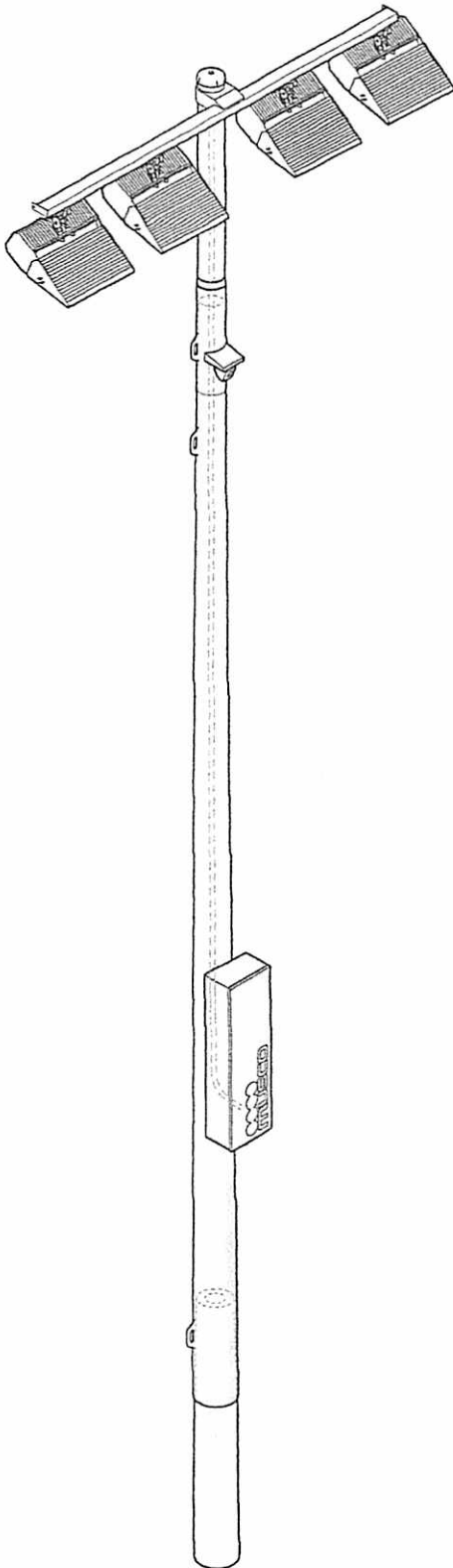

### Overview

The galvanized steel pole is designed to slip-fit together with the precast concrete base and the poletop luminaire assembly.

### Features

- Slip-fit connection allows pole assembly with come-alongs
- Built-in hardware for attaching electrical components enclosure
- Wire access from inside the pole (no exposed wiring or conduit)
- Shipped in sections for easier handling
- Labeled with pole identification for location on field

### Technical Specifications

Pole dimensions vary. For measurements refer to project specific pole configuration drawing.

### Construction

- Pole designs comply with all major building codes
- High strength, low alloy, tapered, round steel pole
- Hot-dip galvanizing inside and outside after fabrication meets ASTM-A123 and EN 1461 standards
- Conforms to AASHTO stress standards and BS EN 40-3-1
- Grounding lug—rated for aluminum (AL) or copper (CU) wiring
- Pole shipped in sections
- Stainless steel fasteners passivated and coated
- Material certifications are available

### Quality Assurance Tests

- Bending stress
- Minimum galvanizing thickness
- Straightness measurement

**RESOLUTION NO. \_\_\_\_\_**

**WHEREAS**, the City of Fairhope is desirous to protect the health, safety, and general welfare of the people by establishing the Rules and Code of Conduct for the Adult Leagues at the Mike Ford Tennis Center at Fairhope Stimpson Park; and

**WHEREAS**, the City of Fairhope hereby proposes the following Adult League Rules and Code of Conduct and Adult League Fees for the Mike Ford Tennis Center at Fairhope Stimpson Park (attached as Exhibit A); and

**NOW BE IT RESOLVED BY THE GOVERNING BODY OF THE CITY OF FAIRHOPE, ALABAMA**, That the City of Fairhope approves the Adult League Rules and Code of Conduct; and the Adult League Fees for the Mike Ford Tennis Center for Fairhope Municipal Tennis Courts as proposed by the Recreation Board.

DULY ADOPTED THIS 23RD DAY OF FEBRUARY, 2017

\_\_\_\_\_  
Karin Wilson, Mayor

Attest:

\_\_\_\_\_  
Lisa A. Hanks, MMC  
City Clerk



# **MIKE FORD TENNIS CENTER In Fairhope at Stimpson Park**

## **Adult Leagues Rules and Code of Conduct**

Effective MARCH 1st

### **Captain's responsibilities:**

- Every Team Captain, prior the new league sign up begins, **must send written request regarding the use of Mike Ford Tennis Center as their home site.**
- Captain must send the league schedule (once officially published) to Tennis Manager. Tennis Manager will schedule all the home matches. Soft courts and hard courts will be scheduled upon the captain's request. City of Fairhope will do the best to accommodate soft court or hard court requests but will not guarantee assigning all 6 or all requested soft courts or hard courts for every home match.
- Captain and team must check and confirm their court reservations, 2 days prior their home match. Captain's will be responsible for the courts availability and match court reservations.
- League Fee: \$50.00 per player per season for nonmembers. Member has to be in good standings during the entire duration of the season.
- Captain is ultimately responsible for collecting all the league play fees.
- All the fees have to be paid prior the start of the new season.

### **City of Fairhope "Resident" and "Member" league sign up rules:**

1. Every Team Captain must make his/her team available for the City of Fairhope residents or members and must allow them to sign up if all following rules apply:
  - The limit of maximum players on the team hasn't been reached.
  - If the player has a same USTA rating (2,5; 3.0; 3.5; 4.0; 4.5 etc.) or one level lower playing rating as team's league rating.
2. City of Fairhope is not responsible for the captain's decisions regarding the team line up, match scheduling and doubles teams pairing.

Captain is responsible for providing all the information related to the league play to their players (Sign up information, schedule, scheduling, team line up, site court information and court assignment, etc).

## Minutes of the Fairhope Recreation Board

January 18, 2017

The Fairhope Recreation Board met Wednesday, January 18, 2017 at 5:15 p.m. in the Rec Center at 803 North Greeno Road.

Present were Sherry Sullivan, Mary Gammer (left meeting at 6:37 p.m.), Charlie Langham, Jay Robinson, Bob Keyser, Tom Kuhl, Vann Saltz, Derek Thomas, Cathy Hudson, and Robert Brown (arrived at 5:25 p.m.). Absent: Michele Smith. Gayle Fogarty took minutes at the meeting.

The meeting was called to order by Vann Saltz at 5:17 p.m. The minutes of the October 19, 2016 meeting minutes were considered and approved on a motion by Bob Keyser, seconded by Mary Gammer, none opposed. Vann Saltz introduced and welcomed Jay Robinson, City Councilmember to the Rec Board.

**Tennis Center Update:** Tomas Cartar provided an update to the board members, he stated that the Tennis Center has 40 new members, 44 new add on members to the Rec Center memberships and 988 Day Passes have been purchased since the center opened. Tomas added that more tennis could be played if the lights were installed, the \$125,000 expense for the lights has been requested in the upcoming budget. He also presented the Rec Board with *Adult League Rules and Code of Conduct* for the Mike Ford Tennis Center in Fairhope at Stimpson Park, and asked the board to review and recommend the *Adult League Rules and Code of Conduct* to the City Council for approval. There was general discussion among the board, they agreed to amend the *Adult League Rules and Code of Conduct* to include: League Fee: \$50.00 per player per season for nonmembers. Member has to be in good standings during the entire duration of the season, effective March 1, 2017, a motion was made by Derek Thomas, seconded by Bob Keyer, none opposed to approve the *Rules and Code of Conduct*.

Vann Saltz introduced and welcomed Robert Brown, City Councilmember to the Rec Board.

**Flag Football Update:** Vann Saltz spoke on the Flag Football request that was received from Elizabeth Hammock by e-mail (see attached). Tom Kuhl and Sherry Sullivan expressed some concern with space for games/practices at Founders, Tom agreed it was good for the community. Bob Keyser mentioned that Fairhope Elementary School had space available and Fairhope High School between the band field and the fence. Sherry felt that it could be accommodated, there are logistics to work out. She added that Flag Football would need to complete an application to form a league and provide proof of insurance. Bob Keyser made a motion to support the formation of a Flag Football League, based on the completion of the league application and providing proof of insurance, and seconded by Mary Gammer, none opposed. Tom asked if the children participating in the league would be Fairhope residents, Sherry stated that she would check to be sure.

**Discussion of 5 Year Plan:** There was lengthy discussion among the board members of the 5 Year Plan lead by Bob Keyser, once discussion was complete, Bob Keyser made a motion to present the Recreation Board's 5 Year Plan at the City Council meeting on February 13, 2017, and seconded by Derek Thomas, none opposed.

**Master Plan of Volanta:** Sherry Sullivan presented the Master Plan of Volanta to the board members, there was general discussion among the members.

**Recreation Update:** Tom Kuhl informed the group that the City is in the process of redoing the fields at Founders and the open custodian position has been filled.

**Announcements:** Bob Keyser informed the board members that this is the first year for Fairhope High School to have a Wrestling Program with 23 participants. He added that the next match will be held at FHS on January 19 at 5 p.m., and that FHS Soccer will begin the second week of May.

Cathy Hudson stated that 75 kids are swimming this year and the girls placed 1<sup>st</sup> in the county meet and boys placed 2<sup>nd</sup>.

**Fairhope Soccer Complex:** Sherry Sullivan stated that she is working with Robert Brown and Jay Robinson on this project. She added that the City has applied for a grant for bleachers and sidewalks through ADECA. The opening date for the Fairhope Soccer Complex is March 11, 2017, as well as the opening day for youth soccer. Sherry stated, that due to the cost, signage maybe limited until next budget year. Bob Keyser added that the Buccaneer Bash will be held on March 3-4, 2017, 30 teams are signed up. He requested using the new complex for the Buccaneer Bash, as it could be considered a soft opening for the complex and would make logistics easier for the event by hosting the Bash in one location. There was general discussion among the members, as to whether or not any play should take place on the field prior to opening day. Sherry also informed the group that Master's Swim will donate an AED to the City Pool.

Being no further business, the meeting was adjourned at 6:39 p.m.



**RESOLUTION NO. \_\_\_\_\_**

**BE IT RESOLVED BY THE GOVERNING BODY OF THE CITY OF FAIRHOPE, ALABAMA**, as follows:

[1] That the City of Fairhope approves the procurement of Neptune Gas Meter ERTS for the Gas Department for the fiscal year 2017, to be purchased as needed from Consolidated Pipe & Supply Co., Inc. as Sole Source Provider in the State of Alabama for Neptune Technology Group, Inc. The units must fit into our existing standardized system; and are exempt from formal bid pursuant to Code of Alabama 1975, Section 41-16-51(b)(7). The estimated number of units is 466 ERTS at \$75.00 per unit at a not to exceed annual cost of \$35,000.00.

Adopted on this 23rd day of February, 2017

\_\_\_\_\_  
Karin Wilson, Mayor

Attest:

\_\_\_\_\_  
Lisa A. Hanks, MMC  
City Clerk

## City of Fairhope Project Funding Request

Issuing Date 2/13/2017

Please return this Routing Sheet to Treasurer by

2/13/2017

**FEB 20 '17 10:09**

Project Name: 2017 Purchase Neptune Gas Meter ERTs, to be purchased as needed

*[Handwritten Signature]*

Project Location: Gas System - City Wide

Presented to City Council: 2/23/2017      Approved \_\_\_\_\_ Changed \_\_\_\_\_ Rejected \_\_\_\_\_

Project Cash Requirement Submitted for Approval:      Cost: Not to exceed estimated annual total of \$35,000

Providers: Consolidated Pipe & Supply Co., Inc.  
Mobile, AL - sole source distributor

Project Engineer: n/a

Order Date: \_\_\_\_\_ Lead Time: n/a

**Department Funding This Project**

|         |     |    |          |       |       |         |            |        |
|---------|-----|----|----------|-------|-------|---------|------------|--------|
| General | Gas | xx | Electric | Water | Sewer | Gas Tax | Cap. Proj. | Impact |
|---------|-----|----|----------|-------|-------|---------|------------|--------|

**Division of General Fund Funding This Project**

|                |                 |                       |              |                    |                 |
|----------------|-----------------|-----------------------|--------------|--------------------|-----------------|
| Admin 10 _____ | Police 15 _____ | Fire 20 _____         | Rec 25 _____ | Adult Rec 30 _____ | Street 35 _____ |
| San 40 _____   | Golf 50 _____   | Debt Service 85 _____ |              |                    |                 |

Expense Code 002-16050  
Const - Gas System Improvement

Revenue Code \_\_\_\_\_

Project will be:      Expensed \_\_\_\_\_  
                                 Capitalized xx

Project Financed By:  
Grant: \_\_\_\_\_ Federal - not to exceed amount  
                                 \_\_\_\_\_ State  
                                 \_\_\_\_\_ City

Project Budgeted: \_\_\_\_\_

(Over) Under budget amount: \_\_\_\_\_

Bond: \_\_\_\_\_ Title \_\_\_\_\_ Year \_\_\_\_\_  
Loan: \_\_\_\_\_ Title \_\_\_\_\_ Year \_\_\_\_\_  
Capital Lease: \_\_\_\_\_ Payment \_\_\_\_\_ Term \_\_\_\_\_

Funding: Gas operating funds

City Council prior approval n/a

Request received by City Treasurer 2/13/2017

Request approved by City Treasurer *[Signature]*

Received by Finance Department 2/14/17

Request approved by Finance Director *[Signature]*

Received by Mayor 2/14/17

Request approved by Mayor *[Signature]*

Contact Person: Robert Rohm



## MEMO

To: Deborah Smith, Treasurer  
From: *Daniel P. Ames*  
Daniel P. Ames, Purchasing Manager

Date: February 9, 2017

Re: Placing on City Council agenda approval to procure gas meter ERTs for the Gas Department, over \$15,000

The Gas Department has the need to procure gas meter ERTs, over this fiscal year. The units must fit into our existing, standardized system. These units are exempt from formal bidding per Code of Alabama 1975, Section 41-16-51(b)(7), which states:

*The purchase of equipment, supplies, or materials needed, used, and consumed in the normal and routine operation of any waterworks system, sanitary sewer system, gas system, or electric system, or any two or more thereof, that are owned by municipalities, counties, or public corporations, boards, or authorities that are agencies, departments, or instrumentalities of municipalities or counties and no part of the operating expenses of which system or systems have, during the then current fiscal year, been paid from revenues derived from taxes or from appropriations of the state, a county, or a municipality.*

The estimated number of units for the fiscal year is 466 units from Consolidated Pipe & Supply Co., Inc., of Mobile, AL, the sole-source distributor for the Neptune ERTs. The not-to-exceed cost of this procurement will be \$35,000.00, including freight. This is over the \$15,000.00 City Council approval limit.

**Please compose a greensheet, and move forward to the next available City Council agenda, this procurement approval request for gas meter ERTs, at a not-to-exceed cost of \$35,000.00, for fiscal year 2017.**

Cc: file

## Dan Ames

---

**From:** Robert Rohm  
**Sent:** Thursday, February 09, 2017 2:24 PM  
**To:** Dan Ames  
**Subject:** FW: ERT price 2017

**From:** Micha Lambert [mailto:MLambert@consolidatedpipe.com]  
**Sent:** Wednesday, January 18, 2017 9:39 AM  
**To:** Robert Rohm <robert.rohm@cofairhope.com>  
**Cc:** Clint Steadham <clint.steadham@cofairhope.com>; Terry Holman <terry.holman@cofairhope.com>  
**Subject:** Re: ERT price 2017

Your price is \$75.00 each as it has been for the past several years no increase of any sort. I have you locked in for 2017 at this price. I have 100 on the shelf.

Thanks  
Micha Lambert  
CPS Mobile

**From:** Robert Rohm <robert.rohm@cofairhope.com>  
**To:** Micha Lambert <MLambert@consolidatedpipe.com>  
**Cc:** Clint Steadham <clint.steadham@cofairhope.com>, Terry Holman <terry.holman@cofairhope.com>  
**Date:** 01/18/2017 09:35 AM  
**Subject:** ERT price 2017

---

Micha need a price for 412 ERTS to perchance quarterly for 2017 and ship to American meter when I do a meter order please. Sone as I get a price from Jaye for 2017 I am going to put in a order will need 100 ERTS.

Robert Rohm, Superintendent  
Fairhope Public Utilities  
Gas Department  
555 South Section Street  
Fairhope, AL 36532  
251-928-8003

October 6, 2016

To Whom It May Concern:

At this time Consolidated Pipe and Supply Co. is the only Neptune distributor authorized in the state of Alabama to sell RF meter reading equipment and Neptune water meters and parts. Consolidated Pipe and Supply is authorized by Neptune to submit an offer for Neptune water meters and related products.

Neptune Technology Group is the only manufacturer of Neptune meters. Our headquarters and manufacturing facility is located in Tallassee, Alabama. Additional company information can be found at our website [www.neptunetg.com](http://www.neptunetg.com).



Thank you for your interest in Neptune products. If you have any questions, please contact your local Consolidated Pipe & Supply representative, Micha Lambert 251-533-5239 or your local Neptune representative, Kevin Smith at 334-799-3760.

Regards,

A handwritten signature in black ink that reads "Chris Knapp". The signature is fluid and cursive, with the first letters of the first and last names being capitalized and prominent.

Chris Knapp  
Field Support Manager

**NEPTUNE**  
TECHNOLOGY GROUP INC.

1500 Alabama Highway 229, Tallassee, AL 36078 • 334.283.6555 • [www.neptunetg.com](http://www.neptunetg.com)

**CITY OF FAIRHOPE  
PLANNING COMMISSION COVER SHEET**

**February 6, 2017**

|   |
|---|
| <p><b>SR 16.05</b> Request to consider the request of Chris Haley for Site Plan approval for Portico, a 56-unit project. The property is located at the northeast corner of Fairhope Avenue and Brown Street.</p> |
|---|

**STAFF INTERPRETATION:**

The subject property consists of 3.52 acres and is zoned B-2 (General Business). The proposed project is a mixed use project with seven (7) buildings and 56 units. 33 residential units and 23 commercial units are proposed. The units and buildings are clearly labeled on the plans. All seven (7) buildings are two (2) stories with a building height not to exceed 35'.

The development appears to be in compliance with the City's Zoning Ordinance regarding the minimum standards relative to area and dimensional requirements, the number of parking spaces provided, etc. The mixed use proposal is allowed, subject to Site Plan Review, per the Zoning Ordinance. Please see the attached Site Plan.

The applicant has voluntarily continued the application twice to work with staff on issues related to the site.

The issues identified by staff are as follows:

1. The city's minimum greenspace requirement of 20' along Fairhope Avenue in the Tree Ordinance is not met, per the City Horticulturist. The applicant contends that the combination of the hardscape features and landscaping satisfies the spirit of the 20' greenspace requirement. The applicant also contends that the design proposed will lend to a better transition between the Central Business District and the proposed development. There are also concerns regarding a required greenspace area along Brown Street. Technically, due to the provisions of the Tree Ordinance, if the City Horticulturist does not sign off on the Landscape Plan due to a perceived noncompliance issue, the applicant is required to appeal to the City Judge. Please see the attached Landscape Plan.
2. The second issue relates to the proposed on-street parking. The City has asked the applicant to remove the on-street parking due to public safety concerns.

3. Staff engaged a third party engineer (Larry Smith, P.E. with S.E. Civil Engineering) to review the development for compliance with the City's Subdivision Regulations/Stormwater Standards. Our third party engineer has been working with the applicant and staff and he has provided his final set of comments. His comments shall be satisfied, if approved by the Planning Commission. Please see Mr. Smith's comments attached.

There are no wetlands or significant natural resources on the site. There have, however, been concerns expressed by the Public Works director regarding the drainage flow through the site.

**STAFF RECOMMENDATION:**

While the majority of the project layout appears to be of good design, due to the issues outlined above, staff is unable to support the application.

However, if the Planning Commission and City Council approve the subject development as proposed or with any changes, staff recommends all of Larry Smith's comments be addressed.

Respectfully Submitted for Consideration,

Jonathan I. Smith, MPA  
Planning and Zoning Director  
City of Fairhope



**APPLICATION FOR SITE PLAN APPROVAL**

Application Type:  Site Plan  
Attachments:  Articles of Incorporation or List all associated investors

Date of Application: 10/05/16

**Property Owner / Leaseholder Information**

Name of Property Owner: William Hrus Phone Number: \_\_\_\_\_  
Address of Property Owner: 577 Fairhope Ave.  
City: Fairhope State: AL Zip: 36532

Proposed Site Plan Name: Postico  
Site Acreage: 3.52 acres Sq. Footage: 153,480  
Parcel No: 14769 & 14706 Current Zoning: B-2

**Authorized Agent Information**

Name of Authorized Agent: Chris Haley Phone Number: (251) 648-9532  
Address: 22811 Hwy 98 Suite 1  
City: Fairhope State: AL Zip: 36532  
Contact Person: Chris Haley

**Engineer/Architect Information**

Name of Firm: Lich Engineering Co, LLC Phone Number: (251) 978-9779  
Address: P.O. Box 226  
City: Fairhope State: AL Zip: 36532  
Contact Person: Chris Lich

I certify that I am the property owner/leaseholder of the above described property and hereby submit this site plan to the City for review. \*If property is owned by Fairhope Single Tax Corp. an authorized Single Tax representative shall sign this application.

William Hrus  
Property Owner/Leaseholder Printed Name  
10/05/16  
Date

Will O. Page  
Signature  
Page as FSTC office manager  
Fairhope Single Tax Corp. (If Applicable)

RECEIVED  
OCT 25 2016  
BY: EP





January 20, 2017

Mr. Jonathan Smith, MPA  
Planning and Zoning Director  
City of Fairhope  
555 S. Section Street  
Fairhope, Alabama 36526

Re: Multi Occupancy Third Party Review – Portico  
SD16.32

Dear Jonathan:

We have reviewed the above referenced plans for compliance with Subdivision Regulations and general standards of practice. Below is a list of items that need to be addressed:

**Compliance with Subdivision Regulations:**

1. ~~Section IV.C.1.b (1): The vicinity map is not legible.~~
2. ~~Section IV.C.1.b (8): Plan and Profile of entire water main extension was not provided.~~ It should be noted that the water main extension will require the open cut of the West bound lane of Fairhope Avenue from the eastern corner of the site to Bancroft. This distance is approximate 1528 lf or just over a ¼ of a mile. This work should be coordinated with the public works director for traffic control and road patching.
3. Section IV.C.1.b (8): Provide Utility Availability for Solid Waste. The city of Fairhope does not offer dumpster service. The applicant stated that “Fairhope is an open market for solid waste collection and there are multiple vendors able to service dumpsters in our area”. He is correct in this statement, however a will serve or availability letter still has not been provided.
4. ~~Section IV.C.1.e: Drainage Calculations should be signed and sealed.~~
5. ~~Section IV.C.1.h: Provide a traffic study.~~
6. ~~Section IV.E.3.a: Compact Parking spaces shall be marked by paint at the entrance of the parking stall.~~
7. Section V.F. 3.d: Place the required certification on the drainage calculations. The certification was added, but not signed (page 3)
8. Zoning Section IV.C.5: Loading zones should not block drives or parking spaces. The loading spaces still block parking. I will defer to the planning director on this one.

**General Comments for compliance with Standard Practice:**

1. ~~Provide Calculations for fire line sizing/fire flow.~~
2. The Public Works Director has indicated that a greenspace waiver is denied. This is a major issue that needs to be worked out/addressed as it impacts the parking and overall development. The appropriate channels to remove this requirement need to be followed.
3. ~~Your radius labels are to back of curb which corresponds with your note on sheet C1.0 stating dimensions are to back of curb. However your linear dimensions are to face of curb. Choose either Face of Curb or Back of Curb to avoid conflicts.~~

4. ~~Provide adequate stacking distance for drive through. They have provided stacking for 3 vehicles. The traffic study states this is adequate for a financial institution. It should be noted that when the developer starts leasing space, if something other than a financial institution is put in that space, the stacking will need to be looked at.~~
5. ~~Confirm with Dan McCrory if dumpster drains should be tied to the sanitary sewer system. If so, stormwater should NOT be directed through the dumpster enclosure.~~
6. ~~What LID practices are included in phase 1?~~
7. ~~Provide Bioswale sizing calculations.~~
8. ~~Provide Water Quality Volume calculations.~~
9. ~~The Stormwater Maintenance Agreement provided is for a Subdivision. Modify accordingly for a Site Plan.~~
10. There appears to be two storm lines running through the site from Fairhope Avenue. Little to no information is provided on these lines. I recommend having the lines videotaped in order to determine the condition of the pipe. Further investigation is also needed to determine the elevations of the pipe to ensure there are no conflicts. I recommend the city discuss whether or not an easement over these storm pipes is needed/required. **The applicant stated "These storm drains are the City's responsibility and if maintenance or upgrades are needed it should be provided by the city."** I will defer to the city attorney on who has to maintain these lines. From an engineering standpoint, I would want to know what is going on beneath my project. At least know where these storm lines are going and their elevations.
11. ~~The angled parking along Fairhope Avenue is actually coming into the existing paved area (paved shoulder).~~
12. ~~The angled parking is sloping up from the road leaving an asphalt valley gutter. This will not work. A concrete valley gutter should be installed.~~
13. Most of the ADA parking spaces are over 2% grades. **Double check your grades on Brown Street ADA. The cross slope is 3.7%**
14. Obtain Public Works / City Council approval for angled parking along this section of Fairhope Avenue. **The applicant stated "with this Site Plan submittal applicant is requesting approval by the City Council."**
15. ~~An actual waiver request for the required 10 LID practices was not provided. Provide a letter requesting the waiver with justifications. Your submittal letter has most of the information needed. It just doesn't request a waiver.~~
16. ~~Provide location of all mechanical equipment and means of required screening of mechanical equipment.~~

#### LID Waiver Request Justifications

1. We were able to provide 7 LID techniques. We are requesting a waiver for the requirement for providing 10 techniques.
  - a. We were not able to provide wet basins. The property did not have adequate space to provide an area to be able to have a wet basin, **I do not think space on a site of this size is a good reason, however the fact they did not have to provide detention due to a reduction in impervious surface would be a good reason.**
  - b. We have 3 rain gardens located on the property.
  - c. We have provided pervious paving for a portion of the parking lot.
  - d. We are not able to provide a sand filter. The native soils are drainage class c. **Utilize underdrains.**
  - e. We were able to provide grass swales on the perimeter of the property.
  - f. We were able to provide a grass buffer before the drainage enters the gully.
  - g. Constructed wetlands are not feasible for this project. **Why? Your statement is not a justification. The swale on the East side of the property could have a constructed wetland channel.**



- h. Step pool storm water was not able to be provided due to the limited space. **Again, I don't think limited space is a justification in itself. However, reviewing the grading and drainage plans I do not see a feasible location.**
- i. We do not need storm water detention for the project, therefore we did not provide inline storm water storage.
- j. We were able to provide site design for habitat. The large Oak tree and the native vegetation in the northeast corner of the property is going to be left undisturbed.
- k. There is no existing habitat to restore. The property was previously developed.
- l. We provided a greenway through the western half of the project.
- m. There are no natural channels on site that we could restore.
- n. We have 2 bio-retention cells located in the courtyard.
- o. We did not provide a lever spreader due to leaving the habitat undisturbed by the gully.

I recommend the Planning Commission accept the waiver request with the condition that the applicant incorporate a sand filter and a wetland channel. This would give them 9 LID practices and therefore waiver is still needed.

I did not see a response to the other reviewer's comments. Therefore the applicant should make sure that all other reviewers' comments have been adequately addressed.

If you have any questions, please let me know.

Sincerely,



Larry Smith, PE  
larry@secivil.pro

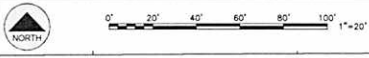

NOTES:  
1. SEE SHEET C1.0 FOR GENERAL NOTES

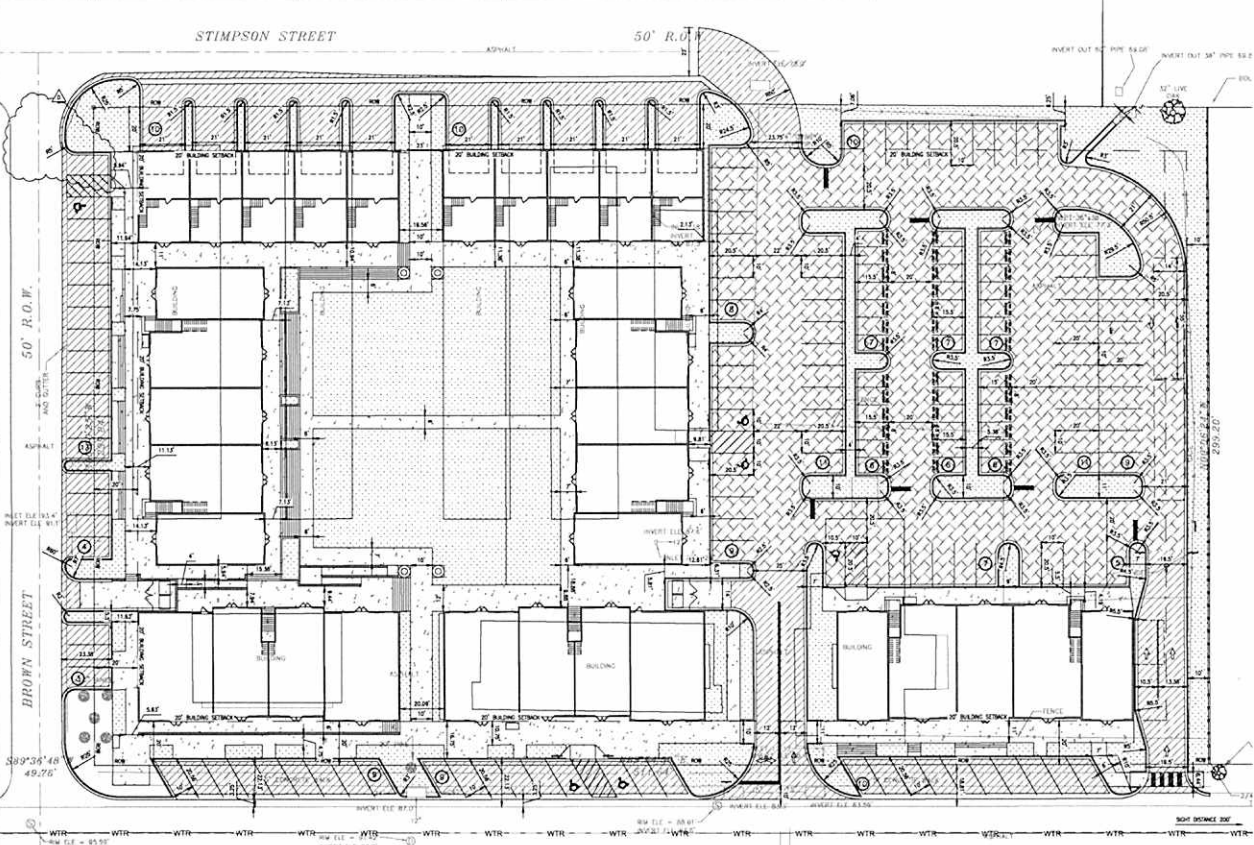

**SITE DATA**

|  |             |
|--|-------------|
| 1. ZONING  | B-2         |
| 2. LOT SIZE  | 2.524 ACRES |
| 3. PROPOSED BUILDING HEIGHT  | 28          |
| 4. TOTAL GROSS FLOOR AREA  | 85,207 SF   |
| 5. PROPOSED BUILDING COVERAGE  | 42.53% SF   |
| 6. PROPOSED PAVING AREA  | 21,128      |
| 7. PERCENTAGE OF LANDSCAPING   | 20%         |
| 8. PROPOSED # OF PARKING SPOTS   | 143         |
| 9. REQUIRED # OF PARKING SPOTS   | 136         |
| 10. PROPOSED COMPACT CAR SPACES  | 47          |
| 11. TOTAL BALCONY  |             |
| 11.1. 2 BAYHORN WEST BUILDING RESIDENTIAL ONLY                                 |             |
| 11.2. 3 OTHER BUILDING COMMON ON FIRST FLOOR                                   |             |
| 12. RESIDENTIAL ON THE SECOND FLOOR  |             |
| 13. MECHANICAL EQUIPMENT WILL BE LOCATED ON THE ROOF AND SCREENED WITH A PANEL |             |

**OWNER:** LEFT RIGGER, LLC  
**PROJECT:** LARK, 36332  
**FILE:** LARK, 36332

THE SITE IS LOCATED IN ZONE B FOR THE LATEST PLAN PUBLISHED BY FIRM

| NO. | DATE       | DESCRIPTION         |
|-----|------------|---------------------|
| 1   | 10/28/2016 | ISSUED FOR APPROVAL |
| 2   | 11/16/2016 | ISSUED FOR APPROVAL |
| 3   | 12/18/2016 | ISSUED FOR APPROVAL |
| 4   | 02/02/2017 | ISSUED FOR APPROVAL |

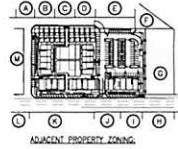

**ADJACENT PROPERTY ZONING**

| ZONING | PARCEL NUMBER           |
|--------|-------------------------|
| A-2    | 08-08-01-21-007-078.205 |
| B-2    | 08-08-01-21-007-078.204 |
| B-2    | 08-08-01-21-007-078.203 |
| B-2    | 08-08-01-21-007-078.202 |
| B-2    | 08-08-01-21-007-078.201 |
| B-2    | 08-08-01-21-007-078.200 |
| B-2    | 08-08-01-21-008-008.110 |
| B-2    | 08-08-01-21-008-008.109 |
| B-2    | 08-08-01-21-008-008.108 |
| B-2    | 08-08-01-21-008-008.107 |
| B-2    | 08-08-01-21-008-008.106 |
| B-2    | 08-08-01-21-008-008.105 |

**PRELIMINARY NOT FOR CONSTRUCTION**      **ISSUED FOR APPROVAL**

**REVISIONS**

| NO. | DATE       | DESCRIPTION         |
|-----|------------|---------------------|
| A   | 10/28/2016 | ISSUED FOR APPROVAL |
| B   | 11/16/2016 | ISSUED FOR APPROVAL |
| C   | 12/18/2016 | ISSUED FOR APPROVAL |
| D   | 02/02/2017 | ISSUED FOR APPROVAL |

**LEB ENGINEERING COMPANY**  
8077 LAKE VIEW DRIVE  
FAIRHOPE, AL 36532  
PH: (205) 978-9779

NOT VALID WITHOUT THE DATED SIGNATURE AND SEAL OF AN ALABAMA LICENSED ENGINEER.  
ALABAMA LICENSED ENGINEER CHRISTOPHER JAY LEE, P.E. LICENSE NUMBER 31204  
ALABAMA CERTIFICATE OF AUTHORIZATION NUMBER 4938

**PORTICO**  
SITE LAYOUT PLAN  
FAIRHOPE, AL  
OWNER: LEFT RIGGER, LLC - HALCY DEVELOPMENT

JOB NUMBER: 2016-033  
DRAWN BY: C.A.  
CHECKED BY: C.A.  
DATE: 10/25/2016  
SCALE: 1" = 20'  
APPROVED BY: C.A.  
ENGR. C.A.

|              |            |
|--------------|------------|
| SHEET NUMBER | 5 OF 12    |
| REV          | C          |
| DATE         | 02/02/2017 |





# SD 16.32 and SR 16.05 Portico

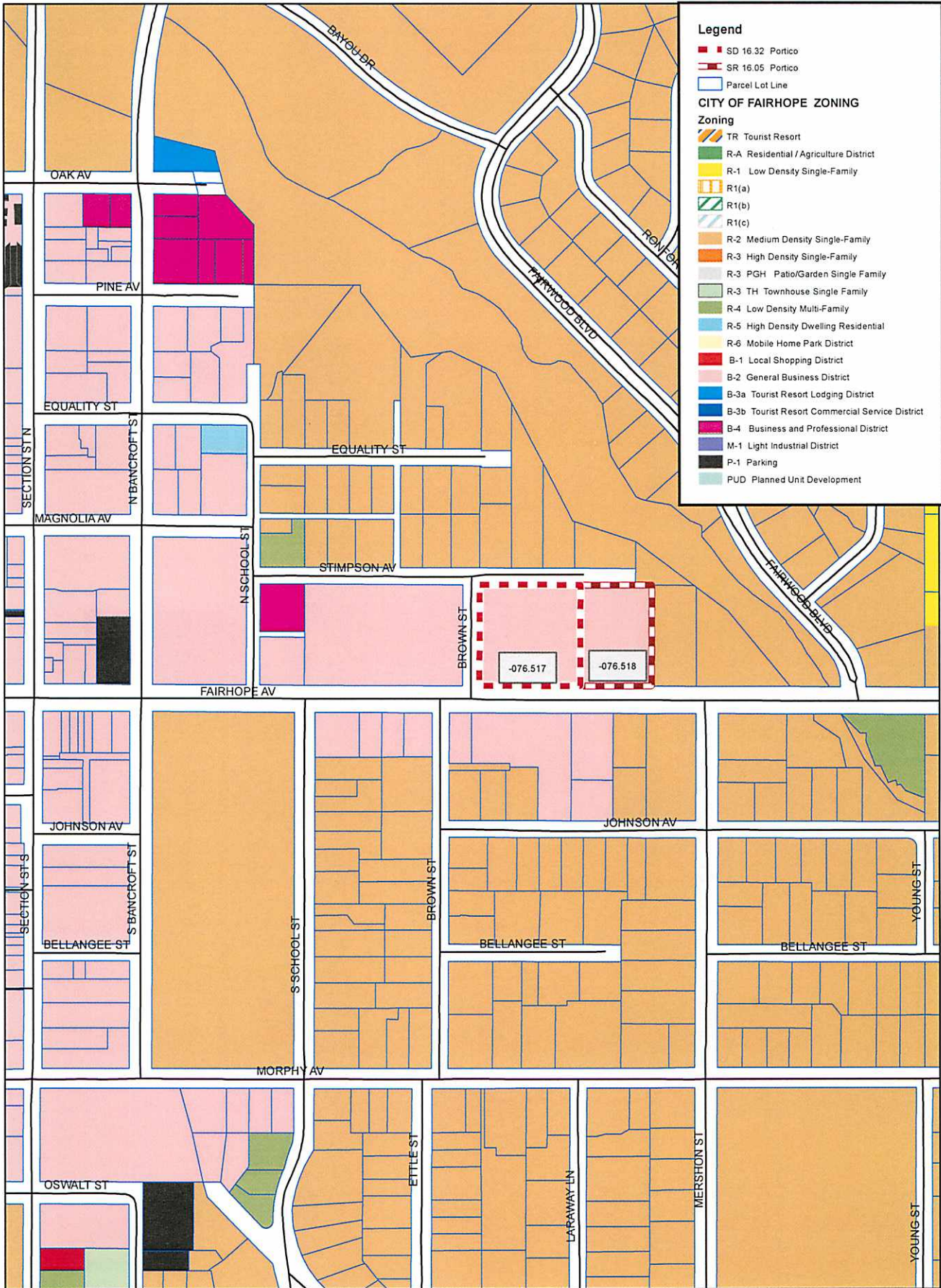

## Legend

- SD 16.32 Portico
  - SR 16.05 Portico
  - Parcel Lot Line
- CITY OF FAIRHOPE ZONING**
- Zoning**
- TR Tourist Resort
  - R-A Residential / Agriculture District
  - R-1 Low Density Single-Family
  - R1(a)
  - R1(b)
  - R1(c)
  - R-2 Medium Density Single-Family
  - R-3 High Density Single-Family
  - PGH Patio/Garden Single Family
  - R-3 TH Townhouse Single Family
  - R-4 Low Density Multi-Family
  - R-5 High Density Dwelling Residential
  - R-6 Mobile Home Park District
  - B-1 Local Shopping District
  - B-2 General Business District
  - B-3a Tourist Resort Lodging District
  - B-3b Tourist Resort Commercial Service District
  - B-4 Business and Professional District
  - M-1 Light Industrial District
  - P-1 Parking
  - PUD Planned Unit Development

SD 16.32 and SR 16.05 Portico  
 Parcel No.: 05-46-03-37-0-007-076.517 and -076.518





# SD 16.32 and SR 16.05 Portico

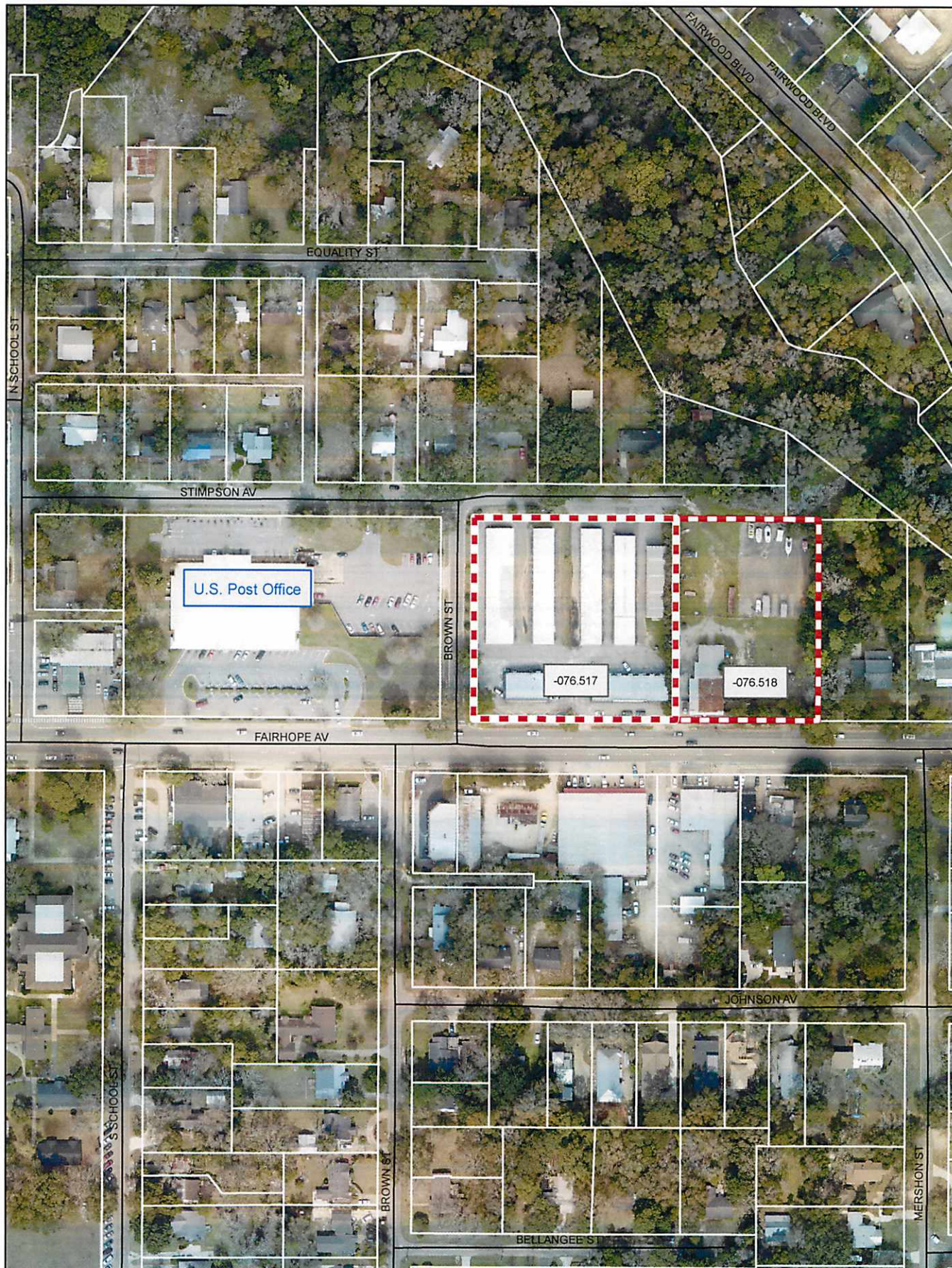

SD 16.32 Portico  
Parcel No.: 05-46-03-37-0-007-076.517  
SR 16.05 Portico  
Parcel No.: 05-46-03-37-0-007-076.518







CITY OF FAIRHOPE  
P.O. DRAWER 429  
FAIRHOPE, AL 36533  
251/928-2136

ALCOHOLIC BEVERAGE LICENSE APPLICATION

PLEASE PRINT

We hereby apply for a license to sell Alcoholic Beverages in the City of Fairhope or its Police Jurisdiction. We agree to abide by all applicable Ordinances of the City, or any amendments to same, and to promptly furnish all reports required by the City.

APPLICANT'S NAME American Cancer Society Inc SSN# \_\_\_\_\_

AGE \_\_\_\_\_ DATE OF BIRTH \_\_\_\_\_ PLACE OF BIRTH \_\_\_\_\_

MAILING ADDRESS 250 Williams Street Atlanta, GA. 30303

HOME # \_\_\_\_\_ WORK # \_\_\_\_\_

CELL # 251-604-4528 FAX # \_\_\_\_\_

RESIDENCE ADDRESS \_\_\_\_\_ 36582

NO. YEARS AT PRESENT ADDRESS 2 NO. YEARS AT PREVIOUS ADDRESS 30

PREVIOUS ADDRESS 504 Ridgelaun Drive West Mobile, AL. 36608

NAME AND ADDRESS OF BUSINESS Black Out Cancer Ball 3-31-17  
161 N. Section street Fairhope, AL, 36532 6:30p.m. - 11:30p.m

NAME OF CORPORATION American Cancer Society Inc.

BUSINESS LOCATION \_\_\_\_\_

HAS APPLICANT EVER HAD AN ALCOHOLIC BEVERAGE LICENSE BEFORE Yes

IF SO, WHERE Fairhope UNDER WHAT NAME same

HAS APPLICANT EVER BEEN ARRESTED NO IF SO, WHERE \_\_\_\_\_

WHEN \_\_\_\_\_ WHAT WAS CHARGE \_\_\_\_\_

DISPOSITION \_\_\_\_\_

LIST THREE REFERENCES:

| NAME                 | ADDRESS | PHONE NUMBER |
|----------------------|---------|--------------|
| Mayor Sandy Stimpson |         |              |
| Joy Frodnick         |         |              |
| Marc Bunting         |         |              |

City of Fairhope  
Alcoholic Beverage  
License Application  
Page -2-

**PLEASE SELECT TYPE OF LICENSE APPLYING FOR:**

- 011 - PACKAGE STORE LICENSE** – Allows sale of liquor, wine, or beer at Retail, TO GO only. No one under age 21 allowed on premises. A liquor tax of 10% City Limits or 5% Police Jurisdiction is due the 10<sup>th</sup> of each month on the purchase price paid for all liquor for use or resale by the licensee.
- 010- LOUNGE LIQUOR LICENSE** – Allows sale of liquor, wine, or beer for on and off consumption. No one under age 21 allowed on the premises. A liquor tax of 10% City Limits or 5% Police Jurisdiction is due the 10<sup>th</sup> of each month on the purchase price paid for all liquor for use or resale by the licensee.
- 031- CLUB LIQUOR LICENSE** – Allows sale of liquor, wine, or beer but must meet ABC Board's "club" regulations. A liquor tax of 10% City Limits or 5% Police Jurisdiction is due the 10<sup>th</sup> of each month on the purchase price paid for all liquor for use or resale by the licensee.
- 020 - RESTAURANT LIQUOR LICENSE** – Allows sale of liquor, wine, or beer for on-premises consumption only and 51% of gross receipts must come from the sale of food. A liquor tax of 10% City Limits or 5% Police Jurisdiction is due the 10<sup>th</sup> of each month on the purchase price paid for all liquor for use or resale by the licensee.
- 140 - SPECIAL EVENTS LICENSE**
- 160 - SPECIAL RETAIL LICENSE** – More than 30 days
- 040 - BEER ON/OFF PREMISES LICENSE** – Allows sale of Beer Only, on and off consumption.
- 050 - BEER OFF-PREMISES LICENSE** – Allows sale of Beer Only, TO GO only.
- 060 - WINE ON/OFF PREMISES LICENSE** – Allows sale of Wine Only, on and off consumption.
- 070 - WINE OFF-PREMISES LICENSE** – Allows sale of Wine Only, TO GO, only.
- 100 - WINE WHOLESALE LICENSE**
- 210 - WINE IMPORTER LICENSE**
- 200 - WINE MANUFACTURER LICENSE**
- 240 - NON-PROFIT TAX EXEMPT LICENSE**

**I STATE ALL THE ABOVE TO BE TRUE AND CORRECT TO THE BEST OF MY KNOWLEDGE.**

*Blair D. Yellin*  
SIGNATURE (FULL NAME)

2.14.17  
DATE

NOT APPROVED \_\_\_\_\_ DATE \_\_\_\_\_  
Chief of Police

NOT APPROVED \_\_\_\_\_ DATE \_\_\_\_\_  
BY COUNCIL \_\_\_\_\_  
City Clerk

APPROVED *Joseph H. Pettin* DATE 02-20-17  
Chief of Police

APPROVED \_\_\_\_\_ DATE \_\_\_\_\_  
BY COUNCIL \_\_\_\_\_  
City Clerk

\*\* The Chief of Police is only acquiring a background check on the owners, partners, or corporate officers of the business for the City of Fairhope. The Alabama Alcoholic Beverage Control Board does a thorough Federal and State background check before issuing the License.